

REVISIONS				
LTR	DESCRIPTION	DATE	CHG NO.	APPRD
A	DISCH HD CAP CHG - 36.87 WAS 35.62	05FEB01		DWS
B	REVISED HEAT EXCHANGER	04MAY01	2001-114	DWS
C	DCM1101 WAS DCM01100	22MAY01	2001-139	DWS
D	CLEARANCE REQUIREMENT WAS 2.50	28JAN02		DWS
E	REPLACED SUCTION HEADS WITH 2810110 ADDED COVER ASSEMBLY	16JUN11	7433	EAS2
F	ADDED SPACERS - PART NO. 3301201	16JUN11	7433	EAS2

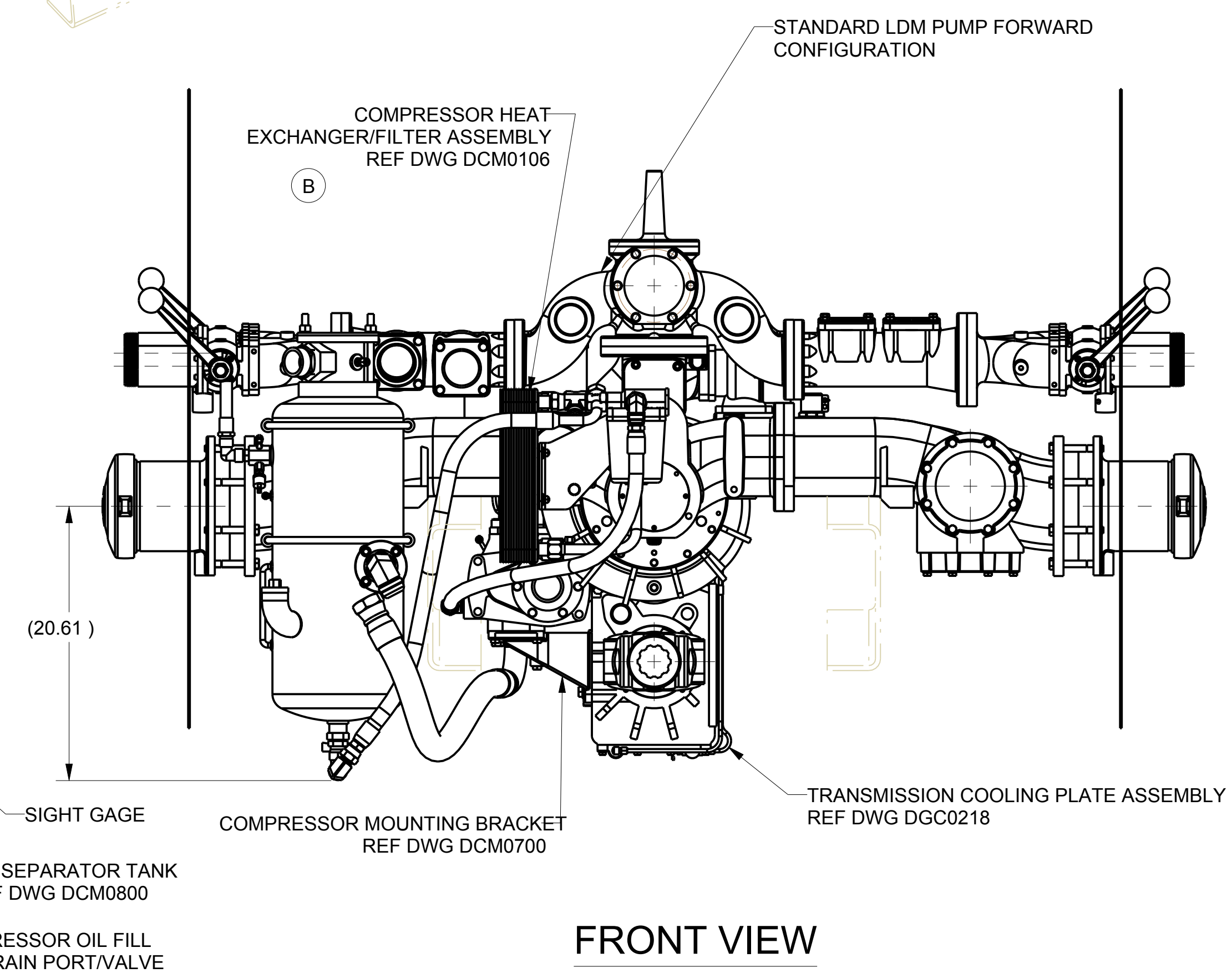
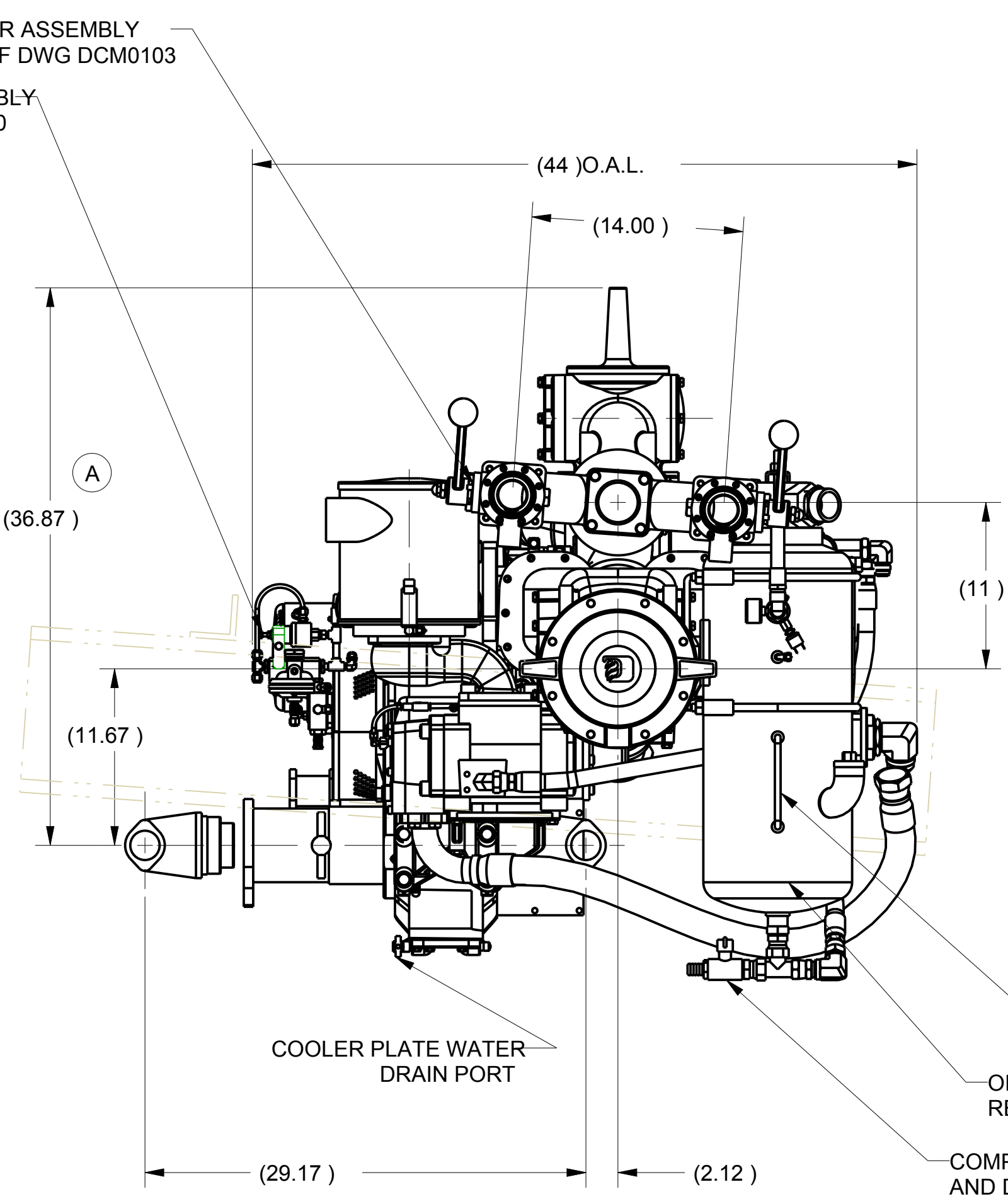
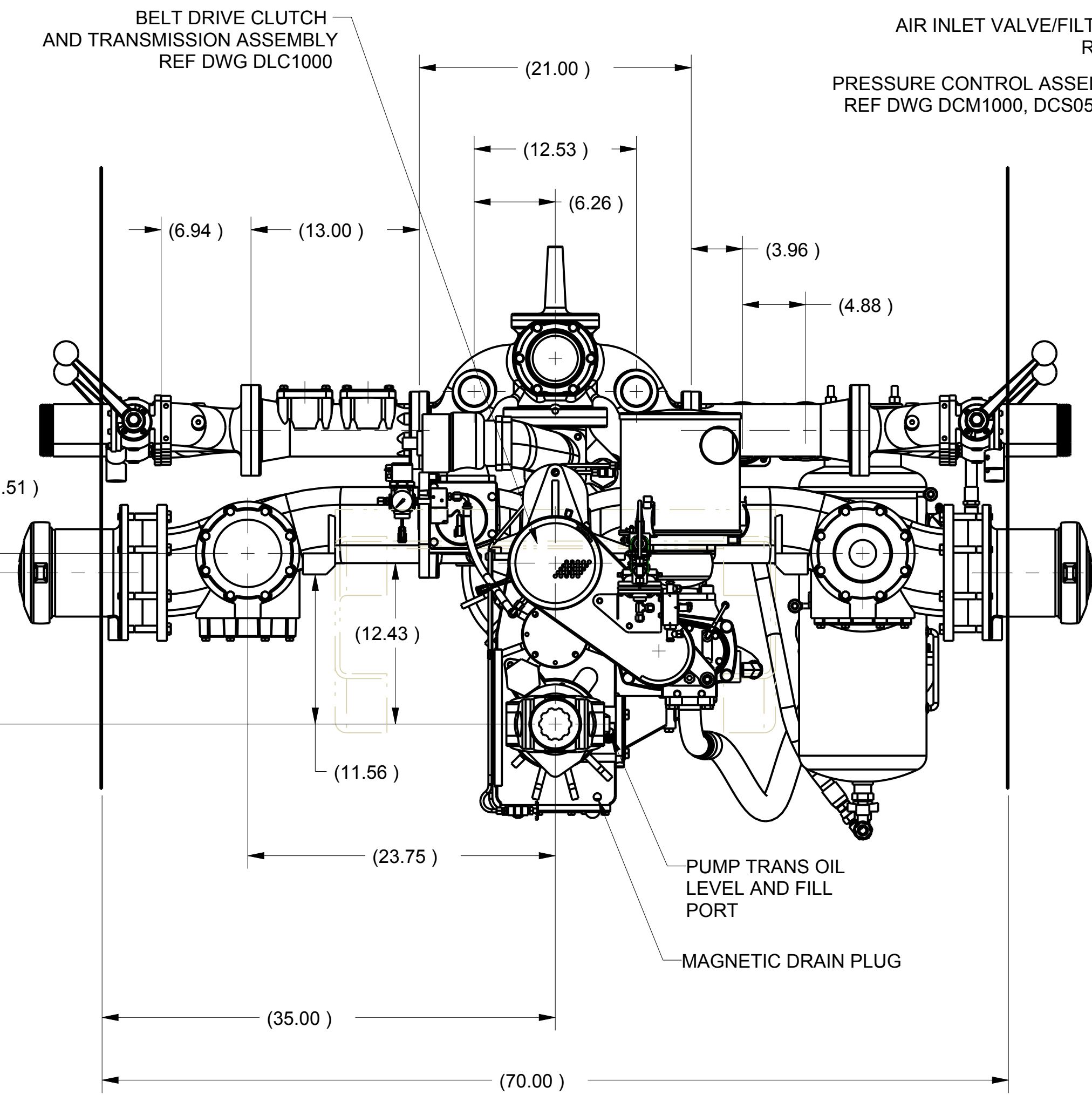
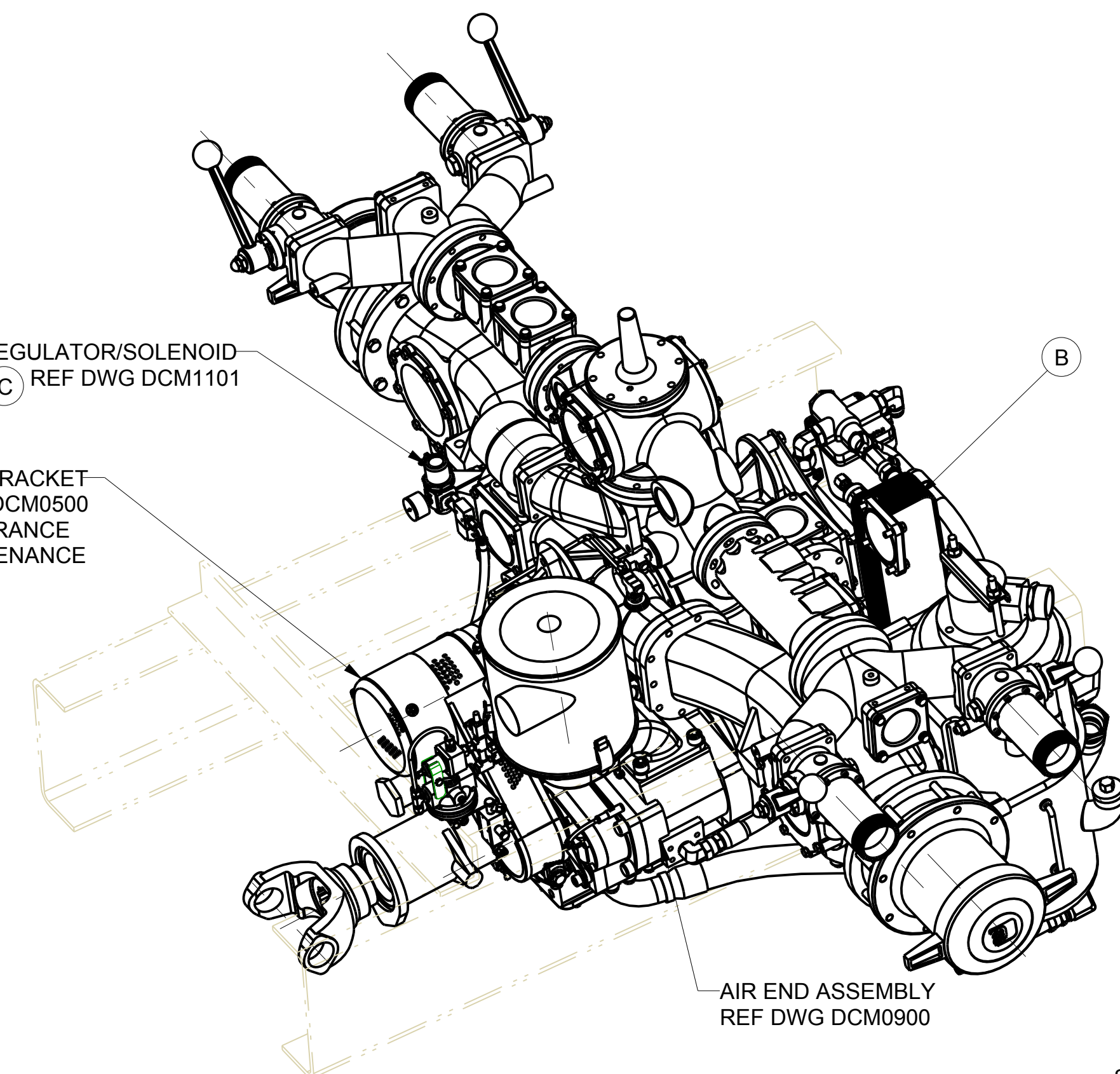
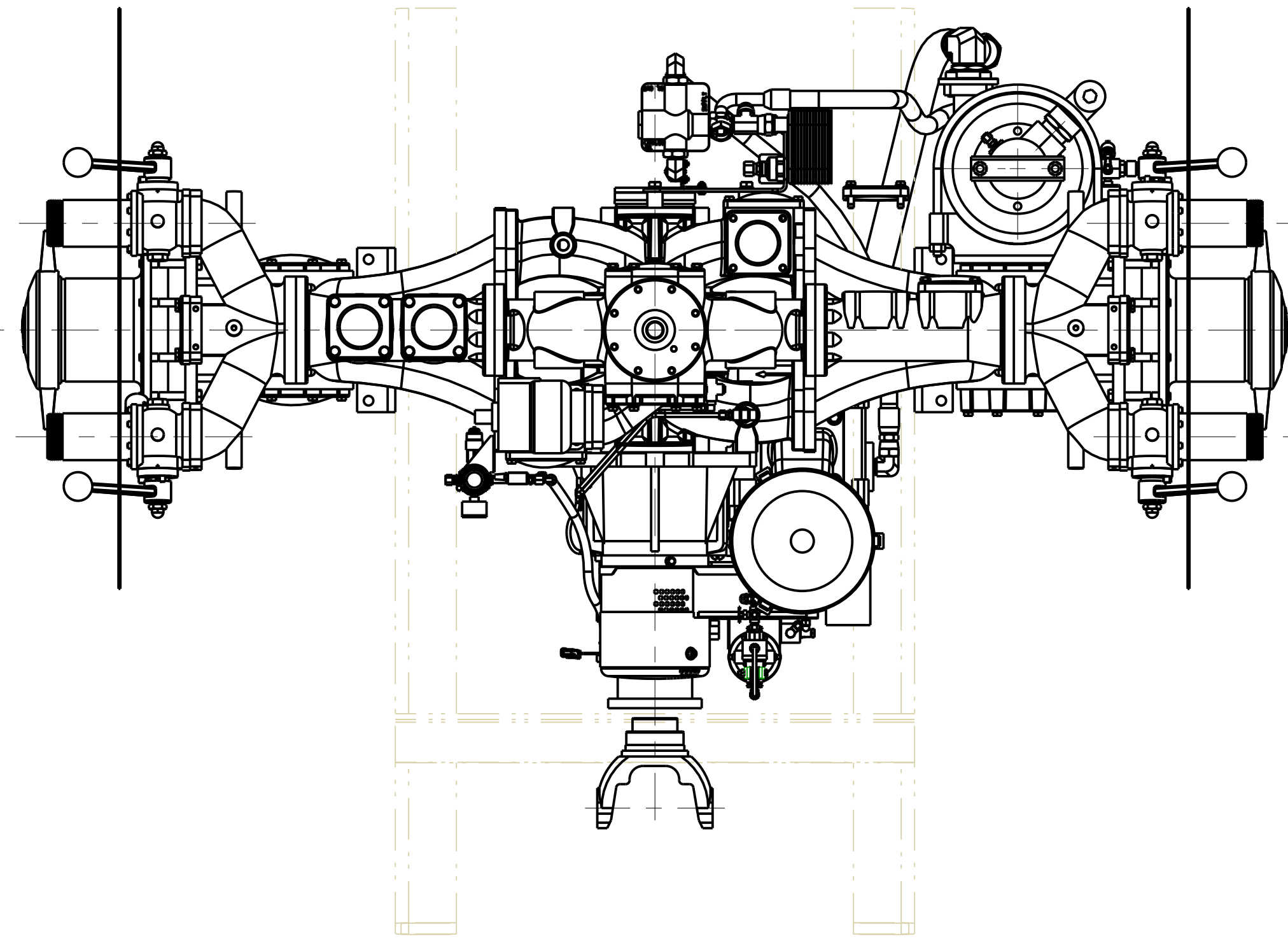

REAR VIEW

FRONT VIEW

REMOVE SHARP EDGES		INCH (MILLIMETER)	OLD PART NO.	TOLERANCE EXCEPT AS NOTED	W.S. Darley & Co. ITASCA, IL - CHIPPEWA FALLS, WI
MATERIAL DESCRIPTION: TBD	MATERIAL NO.	PATTERN NO.	00 ±.03 2000 ±.010 ANGLES ±.1°	LDMBC - LAYOUT BELT DRIVEN COMPRESSOR	DATE 15-Jun-99
THIS DESIGN IS THE PROPERTY OF W.S. DARLEY AND CO. - UNAUTHORIZED REPRODUCTION IS PROHIBITED		ALL DIMENSIONS IN INCHES UNLESS NOTED	DO NOT SCALE PRINT	DRN DWS CHKD TRCD	SCALE 1/8

DLD0500



REVISIONS				
LTR	DESCRIPTION	DATE	CHG NO.	APPR'D
B	REVISED HEAT EXCHANGER AND HOSE	04MAY01	2001-114	DWS
C	KC02802 REPLACED KC02800	22MAY01	2001-139	DWS
D	REPLACED SUCTION HEADS WITH 2810110 ADDED COVER ASSEMBLY	16JUN11	7433	EAS2
E	ADDED SPACERS - PART NO. 3301201	16JUN11	7433	EAS2

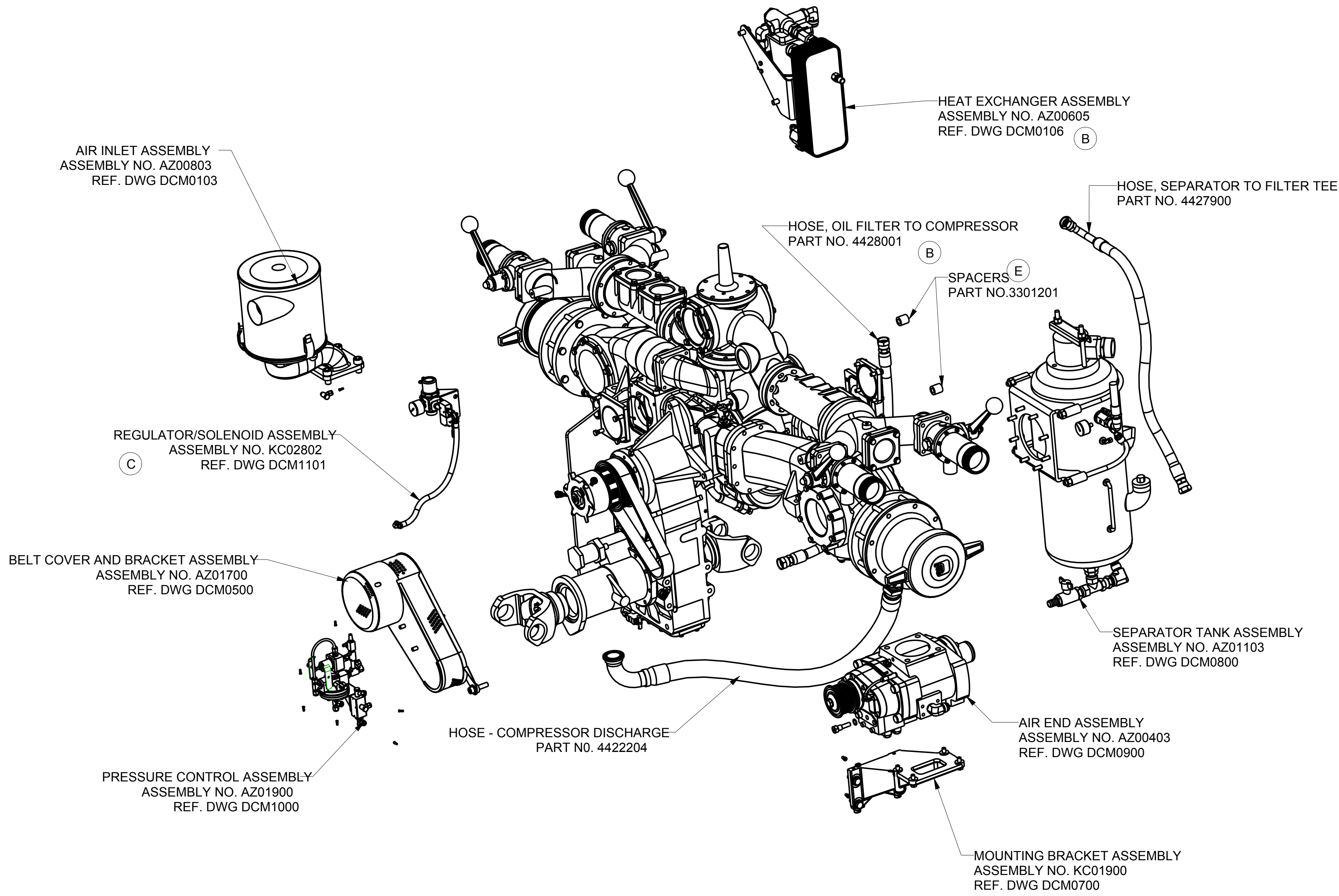

MODEL NAME	MDL CREATED	SHEET
DLD0500	05-JAN-1999	2/2 C

REMOVE SHARP EDGES	INCH (MILLIMETER)	THIRD ANGLE PROJECTION	OLD PART NO.	TOLERANCE EXCEPT AS NOTED .00 ±.03 .000 ±.010 ANGLES ±1°	 ITASCA, IL - CHIPPEWA FALLS, WI LDMBC - LAYOUT BELT DRIVEN COMPRESSOR
MATERIAL DESCRIPTION: TBD				DR'N DWS CHKD - TRCD	
THIS DESIGN IS THE PROPERTY OF W.S. DARLEY AND CO. - UNAUTHORIZED REPRODUCTION IS PROHIBITED	ALL DIMENSIONS IN INCHES UNLESS NOTED	DO NOT SCALE PRINT		DATE 11-Oct-00 SCALE 1/8	DLD0500