

NAME:SMS OBJECT:DLC1003\_1 DATE:09-Sep-10 08:47:31

NO.	DESCRIPTION	PART NO.	QTY.
1	AIR CYLINDER - 1.75 BORE	-	1
2	BEARING - 22206 PC-3	-	2
3	BEARING CAP - IDLER	-	2
4	BEARING-BALL, 113MSFF	-	2
5	BEARING-BALL, 114MSFCO	-	1
6	BEARING-BALL, 213SF	-	1
7	BEARING-BALL, 213SFF	-	1
8	BEARING-BALL, 305SFF	-	1
9	BEARING-BALL, 308SF	-	1
10	BEARING-BALL, 316SFF	-	1
11	BEARING-BALL, 5007.2R5R	-	2
12	BRACKET - BEARING, FRONT, M	-	1
13	BRACKET - BEARING, REAR NO BRK	-	1
14	BRACKET - THERMOSTAT	-	1
15	CAP - BEARING, LDMC ENDURO12	-	1
16	CLUTCH - 12 VDC W/HARNES	-	1
17	CUP - DRIVE, ELECTRIC CLUTCH	-	1
18	DIPSTICK - M22x2.5 THR'D	-	1
19	END YOKE	-	2
20	FLW - LDMC ELECTRIC CLUTCH	-	1
21	FLWCS - .313-10 X 0.75, GR8	-	3
22	FLINGER - WATER	-	2
23	GEAR - DRIVE, M, BDP, 20 PA	-	1
24	GEAR - IDLER	-	1
25	GEAR - PINION, M, BDP, 20 PA	-	1
26	GEAR - PUMP CLUTCH	-	1
27	GEAR - SLIDING CLUTCH, M	-	1
28	GEARCASE - LDMH/LDMC, PUMP FWD	-	1
29	HEAD - SUCTION, LDM, MECH SEAL	-	1
30	HMS - .313-10 X 3.75, GRF911	-	6
31	HMS - .375-16 X 0.88, GR5	-	8
32	HMS - .375-16 X 1.25, GR5	-	4
33	HMS - .375-16 X 1.75, GR5	-	4
34	HMS - .500-13 X 1.75, GR5	-	2
35	HMS - .500-13 X 2.00, GR5	-	1
36	KEY - SO, 0.25 X 1.00, GR2	-	1
37	KEY - SO, 0.25 X 2.50 GR2	-	1
38	KEY - SO, 0.25 X 3.00 GR2	-	1
39	LOCK BOLT - SHIFT BAR	-	1
40	LOCKWUT	-	2
41	NUT - FLANGE, 1/8-14	-	1
42	O-RING - 20MM X 25MM X 2.5MM	-	1
43	O-RING - 0.88 X 1.12 X 0.12	-	1
44	O-RING - 3.50 X 3.69 X 0.09	-	2
45	O-RING - 4.50 X 4.69 X 0.09	-	1
46	O-RING - 5.00 X 5.25 X 0.12	-	2
47	OIL SEAL - 1.563 ID X 2.250 OD	-	1
48	OIL SEAL - 1.875 ID X 3.005 OD	-	1
49	OIL SEAL - 2.750 ID X 3.505 OD	-	2
50	OIL SEAL - 2.938 ID X 3.756 OD	-	2
51	PELLET - OIL WICK	-	6
52	PIN - DOWEL, .250 X 0.62, GR8	-	2
53	PIN - DOWEL, .313 X 1.00, MIL-SPEC	-	2
54	PLUG - PIPE, 0.375, MAG SOC HD	-	1
55	POST - CLUTCH ANTI-ROTATION	-	1
56	REAR BEARING CAP, M	-	1
57	RETAINER - BEARING, M	-	1
58	RING - CLUTCH CUP PILOT	-	1
59	RING - RETAINER, S160-87	-	1
60	SHAFT - IDLER GEAR, M	-	1
61	SHAFT - PUMP, LDMC, MECH SEAL	-	1
62	SHAFT - TRANSMISSION	-	1
63	SHAFT - TRANSMISSION, EM, LDM	-	1
64	SHCS - .375-16 X 1.00, GR8	-	5
65	SHCS - .375-16 X 1.25, GR8	-	7
66	SHIELD - WATER, KDM/LDM/M	-	1
67	SHIFT BAR - PSN	-	1
68	SHIFT YOKE	-	1
69	SPACER - 1.38 X 1.66 X 1.68	-	1
70	SPACER - 1.38 X 1.69 X 0.62	-	2
71	SPACER - 1.38 X 1.75 X 0.418	-	1
72	SPACER - 1.57 X 2.00 X 0.71	-	1
73	SPACER - 1.75 X 2.40 X 0.86	-	1
74	SPACER - 2.56 X 2.88 X 1.58	-	1
75	SPROCKET - GATES POLY CHAIN	-	1
76	TRANSMISSION COVER ASSEMBLY	-	1
77	VENT - AIR, STRAIGHT	-	1
78	WASHER - 2.56 X 3.00 X .09 STL	-	1
79	WASHER - LOCK, 0.375 ID	-	16
80	WASHER - LOCK, 0.500 ID	-	3
81	WASHER - LOCK, M, 0.375 ID	-	9
82	WIRE - SAFETY	-	1

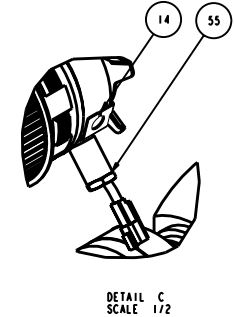
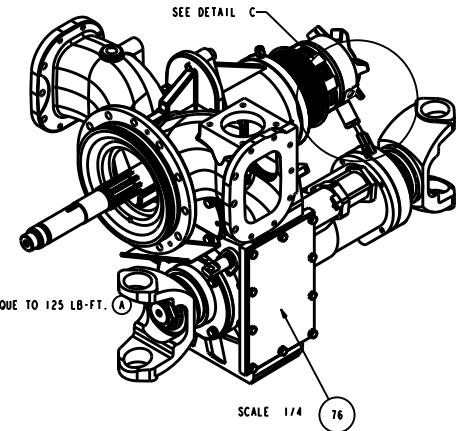
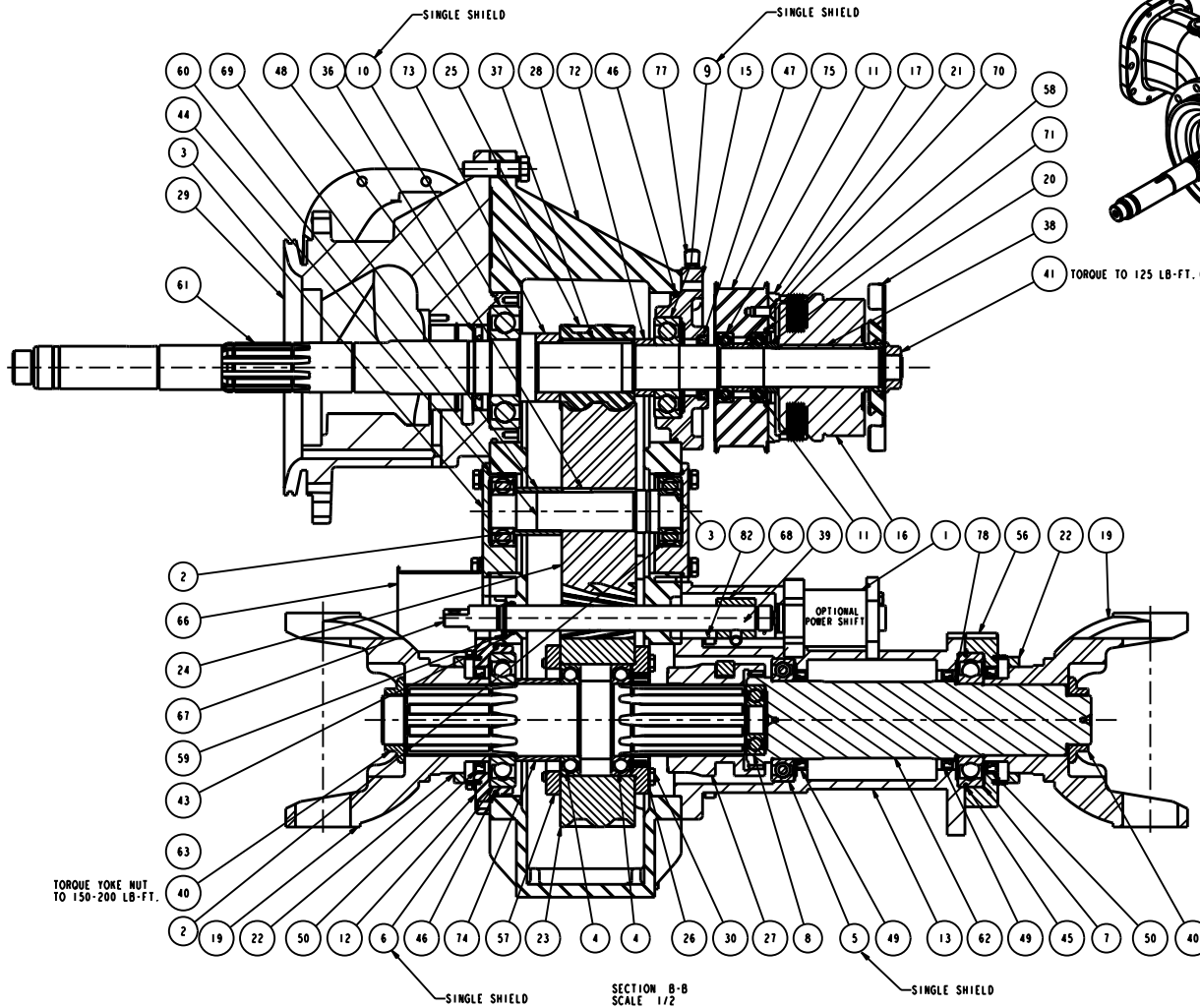

NOTE: DIPSTICK, OIL-WICK PELLET, AND FASTENERS SHOWN ON EXPLODED VIEW (SHEET 2)  
 NOTE: BEARINGS WITH SINGLE SHIELDS - SHIELDED SIDE GOES TOWARD OUTSIDE OF TRANSMISSION

REMOVE SHARP EDGES	1 INCH (25.4 MM) (SEE NOTE)	OLD PART NO.	TOLERANCE	DATE 29-JAN-84
INTERNET DESCRIPTION:		PATTERN NO.	SCALE 1/2	
THIS DRAWING IS THE PROPERTY OF W.S. DUNLAP & CO. UNAUTHORIZED REPRODUCTION IS PROHIBITED. ALL DIMENSIONS IN INCHES UNLESS NOTED. DO NOT SCALE PRINT.				
				<b>DLC1003</b>

REVISIONS				
LT#	DESCRIPTION	DATE	ENG. NO.	APP'D.
4	DIS 15 11-18	10/27/09	2008-231	AKB

NAME:SMS OBJECT:DLC1003\_2 DATE:09-Sep-10 08:47:36

NO.	DESCRIPTION	PART NO.	QTY.
1	AIR CYLINDER - 1.75 BORE	-	1
2	BEARING - 22206 PC-3	-	2
3	BEARING CAP, IDLER	-	2
4	BEARING-BALL, 113MSFF	-	2
5	BEARING-BALL, 114K5FCO	-	1
6	BEARING-BALL, 213SF	-	1
7	BEARING-BALL, 213SFF	-	1
8	BEARING-BALL, 305SFF	-	1
9	BEARING-BALL, 308SF	-	1
10	BEARING-BALL, 310SF	-	1
11	BEARING-BALL, 5007, 2RSR	-	2
12	BRACKET - BEARING, FRONT, N	-	1
13	BRACKET - BEARING, REAR NO BRK	-	1
14	BRACKET - THERMOSTAT	-	1
15	CAP - BEARING, LDMC ENDURO12	-	1
16	CLUTCH - 12 VDC W/HARNES	-	1
17	CUP - DRIVE, ELECTRIC CLUTCH	-	1
18	DIPSTICK - M22x2.5 THR'D	-	1
19	END YOKE	-	2
20	FLW - LDMC ELECTRIC CLUTCH	-	1
21	FLWSC - .313-10 X 0.75, GRB	-	3
22	FLINGER - WATER	-	2
23	GEAR - DRIVE, N, BDP, 20 PA	-	1
24	GEAR - IDLER	-	1
25	GEAR - PINION, N, BDP, 20 PA	-	1
26	GEAR - PUMP CLUTCH	-	1
27	GEAR - SLIDING CLUTCH, N	-	1
28	GEARCASE - LDMH/LDMC, PUMP FWD	-	1
29	HEAD - SUCTION, LDM, MECH SEAL	-	1
30	HMS - .313-10 X 3.75, GRF911	-	6
31	HMS - .375-16 X 0.88, GR5	-	8
32	HMS - .375-16 X 1.25, GR5	-	4
33	HMS - .375-16 X 1.75, GR5	-	4
34	HMS - .500-13 X 1.75, GR5	-	2
35	HMS - .500-13 X 2.00, GR5	-	1
36	KEY - SO., 0.25 X 1.00, GR2	-	1
37	KEY - SO., 0.25 X 2.50 GR2	-	1
38	KEY - SO., 0.25 X 3.00 GR2	-	1
39	LOCK BOLT - SHIFT BAR	-	1
40	LOCKWDT	-	2
41	NUY - FLANGE, 178-14	-	2
42	O-RING - 20MM X 25MM X 2.5MM	-	1
43	O-RING - 0.88 X 1.12 X 0.12	-	1
44	O-RING - 3.50 X 3.69 X 0.09	-	2
45	O-RING - 4.50 X 4.69 X 0.09	-	1
46	O-RING - 5.00 X 5.25 X 0.12	-	2
47	OIL SEAL - 1.563 ID X 2.250 OD	-	1
48	OIL SEAL - 1.875 ID X 3.005 OD	-	1
49	OIL SEAL - 2.750 ID X 3.505 OD	-	2
50	OIL SEAL - 2.938 ID X 3.756 OD	-	2
51	PELLET - OIL WICK	-	6
52	PIN - DOWEL, .250 X 0.62, GRB	-	2
53	PIN - DOWEL, .313 X 1.00, MIL-SPEC	-	2
54	PLUG - PIPE, 0.375, MAG SOC HD	-	1
55	POST - CLUTCH ANTI-ROTATION	-	1
56	REAR BEARING CAP, N	-	1
57	RETAINER - BEARING, N	-	1
58	RING - CLUTCH CUP PILOT	-	1
59	RING - RETAINER, S160-87	-	1
60	SHAFT - IDLER GEAR, N	-	1
61	SHAFT - PUMP, LDMC, MECH SEAL	-	1
62	SHAFT - TRANSMISSION	-	1
63	SHAFT - TRANSMISSION, EM, LDM	-	1
64	SHCS - .375-16 X 1.00, GRB	-	5
65	SHCS - .375-16 X 1.25, GRB	-	7
66	SHIELD - WATER, KDM/LDM/N	-	1
67	SHIFT BAR - PSN	-	1
68	SHIFT YOKE	-	1
69	SPACER - 1.38 X 1.66 X 1.68	-	1
70	SPACER - 1.38 X 1.69 X 0.62	-	2
71	SPACER - 1.38 X 1.75 X 0.411	-	1
72	SPACER - 1.57 X 2.00 X 0.71	-	1
73	SPACER - 1.75 X 2.40 X 0.86	-	1
74	SPACER - 2.56 X 2.88 X 1.58	-	1
75	SPROCKET - GATES POLY CHAIN	-	1
76	TRANSMISSION COVER ASSEMBLY	-	1
77	VENT - AIR, STRAIGHT	-	1
78	WASHER - 2.56 X 3.00 X .09 STL	-	1
79	WASHER - LOCK, 0.375 ID	-	16
80	WASHER - LOCK, 0.500 ID	-	3
81	WASHER - LOCK, MC, 0.375 ID	-	9
82	WIRE - SAFETY	-	1

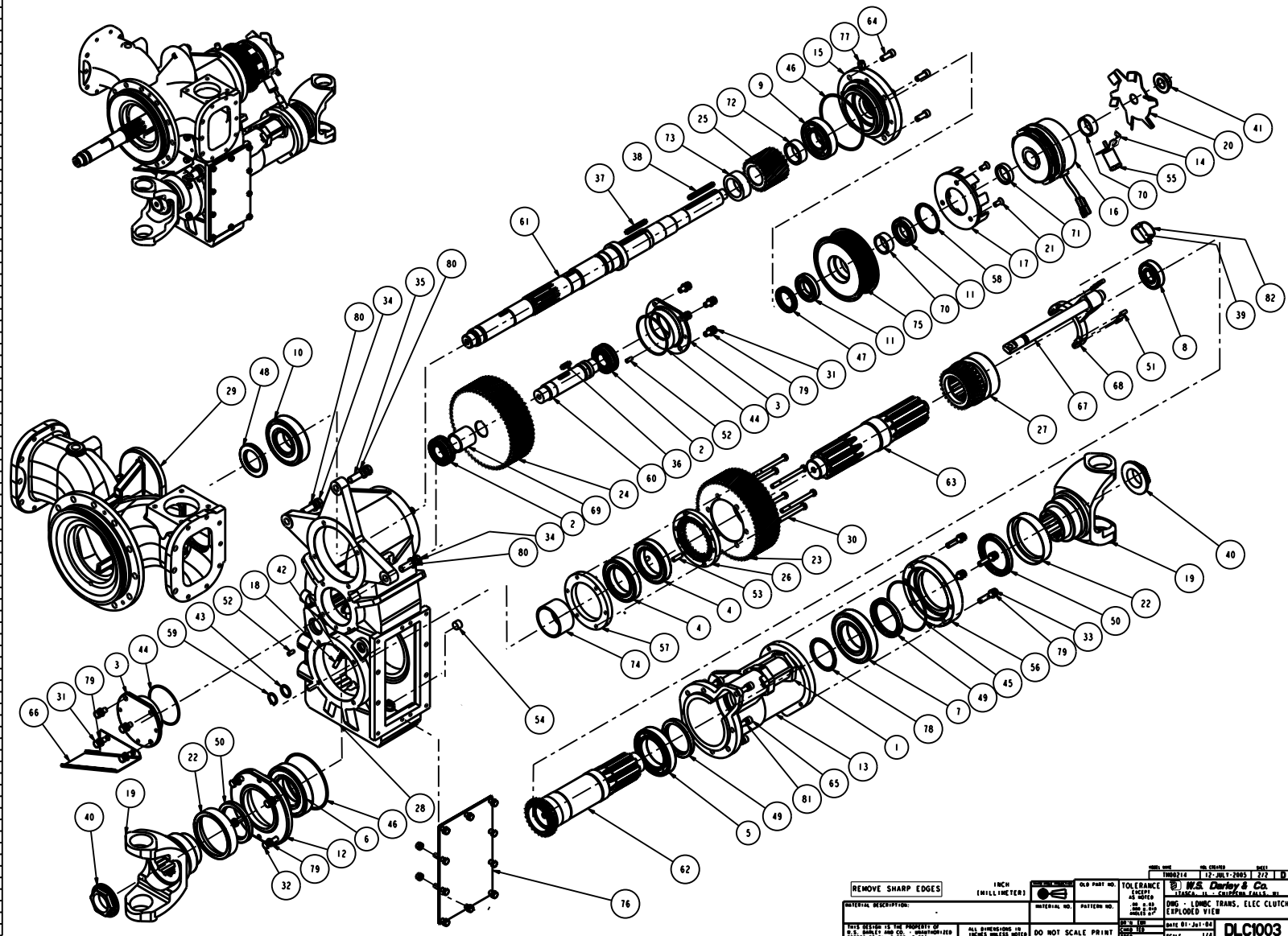

REVISIONS			
LTB	DESCRIPTION	DATE	CHK NO. APP'D
4	ISS 15 11-18	10/27/09	2008-231 AXB

REMOVE SHARP EDGES

1 INCH (25.4 MM) (SCALE)

DATE 01-JUL-04

SCALE 1/24

DLC1003

W.S. Durley & Co. TRANSMISSIONS, LLC

THIS DRAWING IS THE PROPERTY OF W.S. DURLEY & CO. UNAUTHORIZED REPRODUCTION IS PROHIBITED.

ALL DIMENSIONS IN INCHES UNLESS NOTED.

DO NOT SCALE PRINT