

REVISIONS				
LTR	DESCRIPTION	DATE	CHG NO.	APPRD
A	AZ01708 WAS AZ01704. REPLACED INDIVIDUAL CAFS ASSY'S WITH INTEGRATED ASSY.	01/26/12	8051	RJG

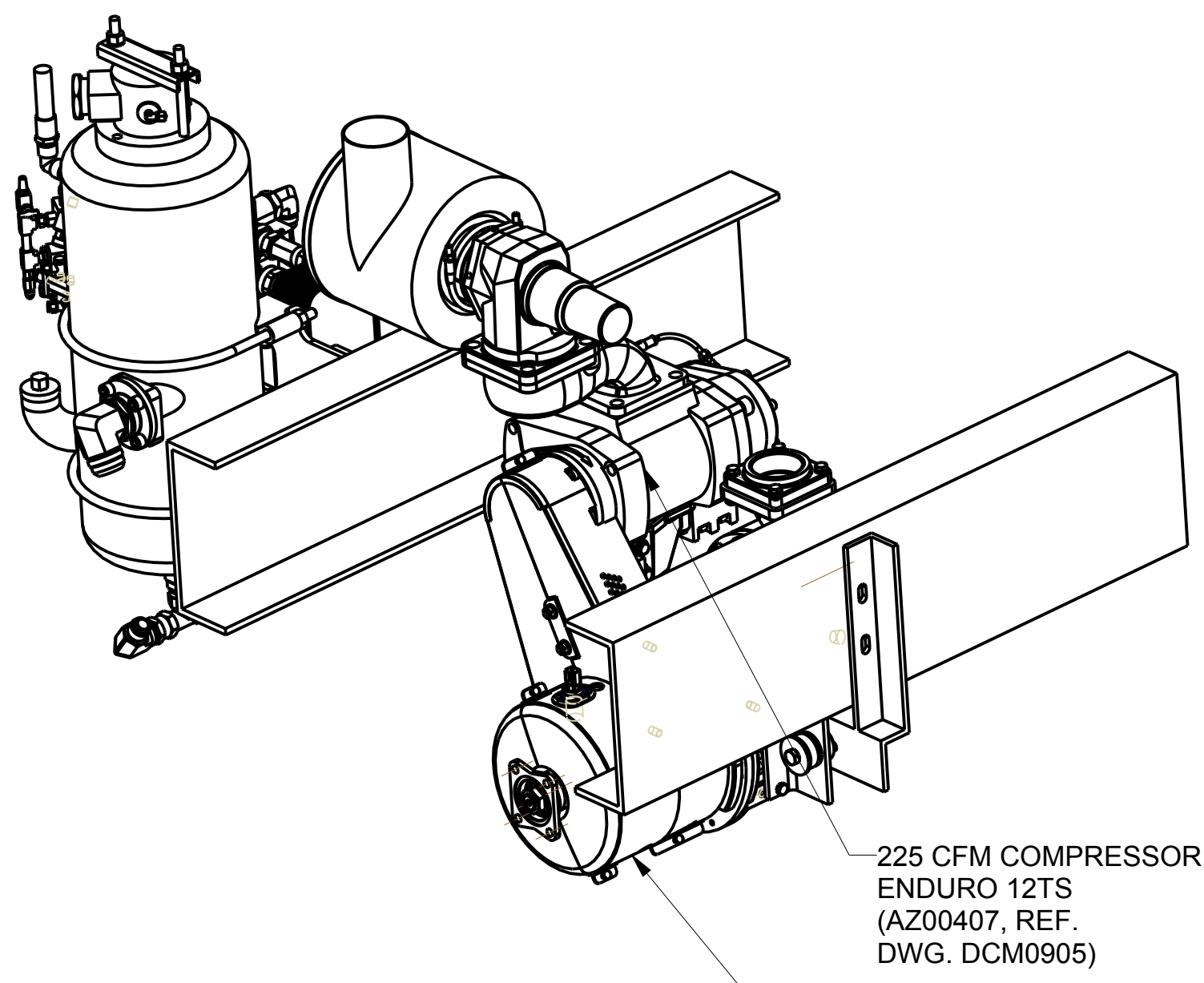

BELT, SPROCKET AND CLUTCH HORIZONTALLY-SPLIT BELT COVER ASSY (AZ01708) (A)

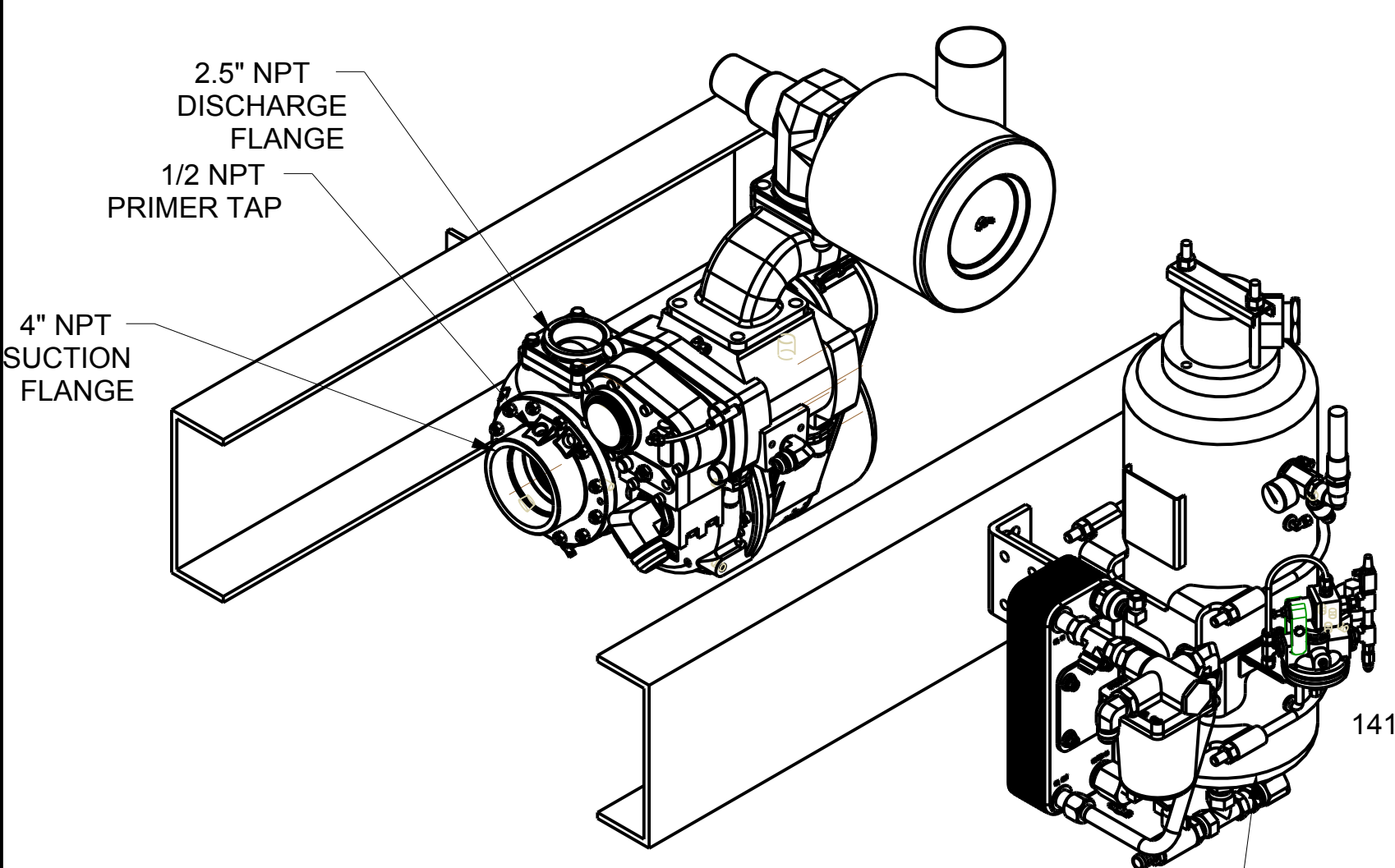
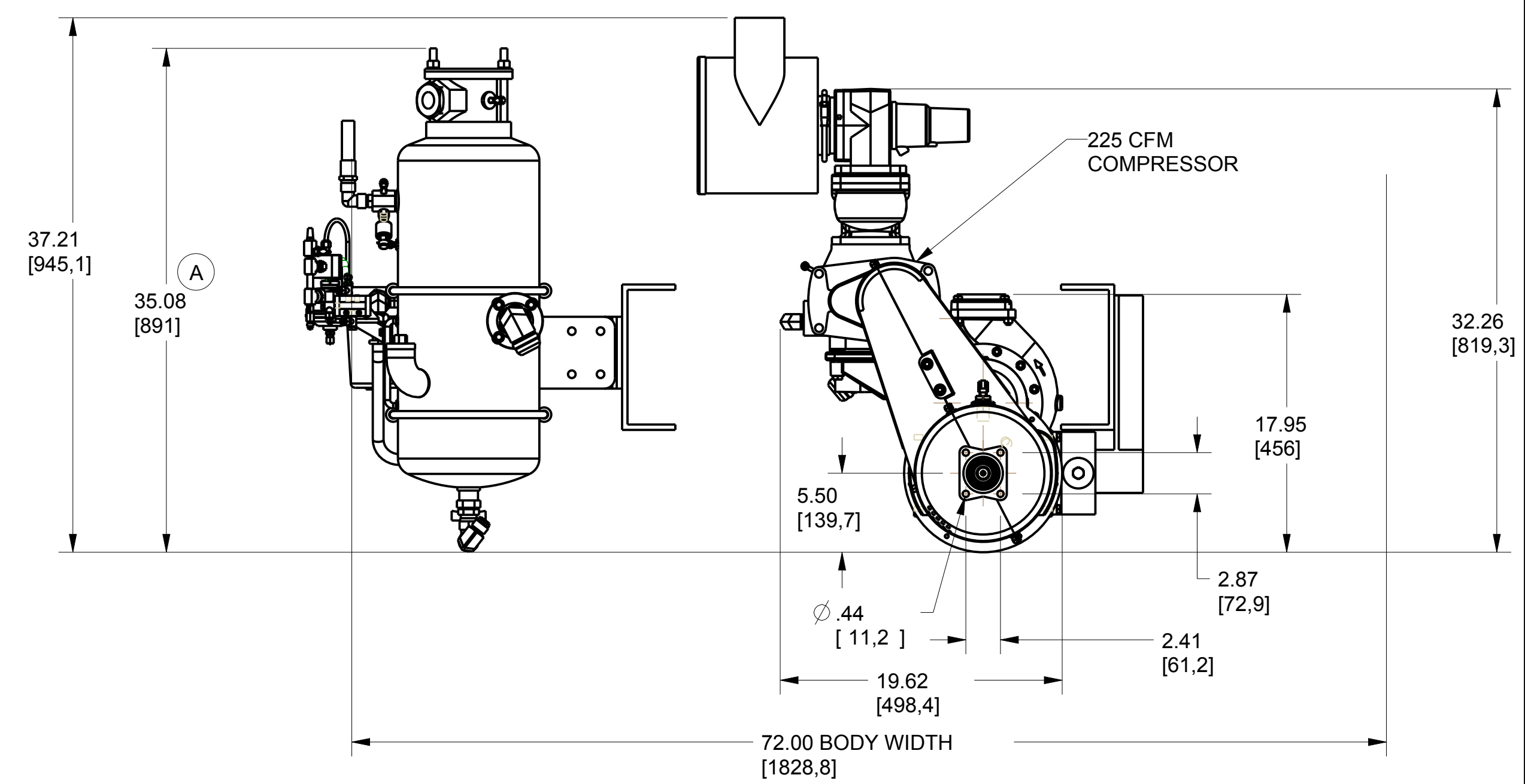
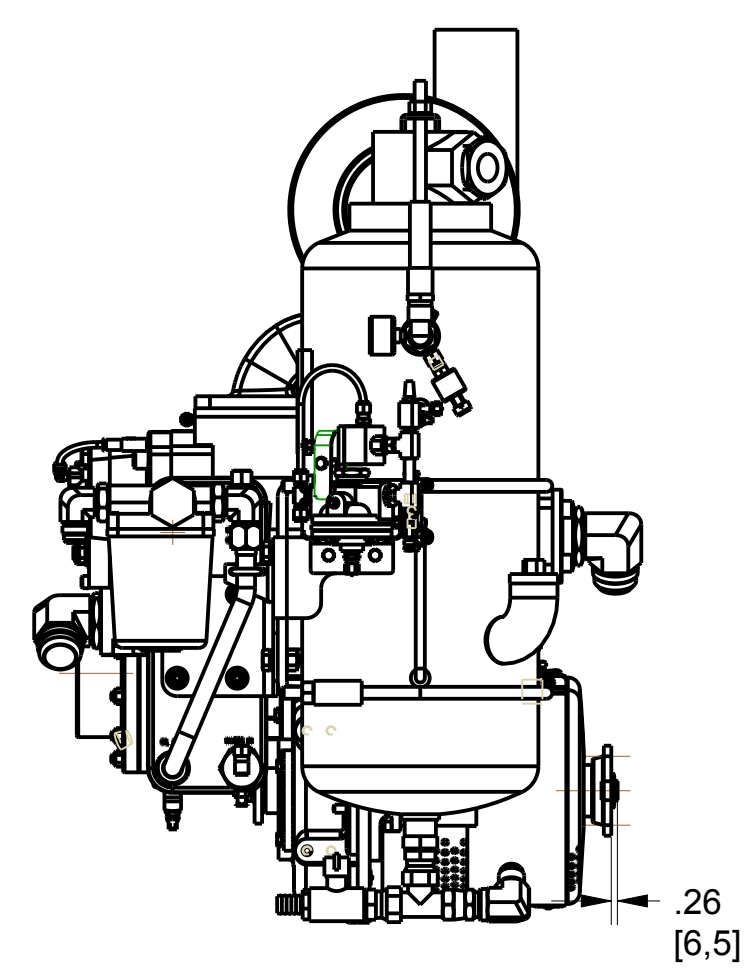

(A) OIL SEPARATOR TANK, HEAT EXCHANGER AND PRESSURE BALANCE VALVE INTEGRATED ASSY.

THIS ASSY CAN BE RELOCATED IN RELATION TO THE PUMP/COMPRESSOR UNIT. RECOMMENDED MOUNTING HEIGHT IS WHERE THE OIL SEPARATOR TANK OIL LEVEL IS AT OR BELOW THE COMPRESSOR ROTOR CENTERLINE. (AZ03201, REF. DWG. DCM1901)

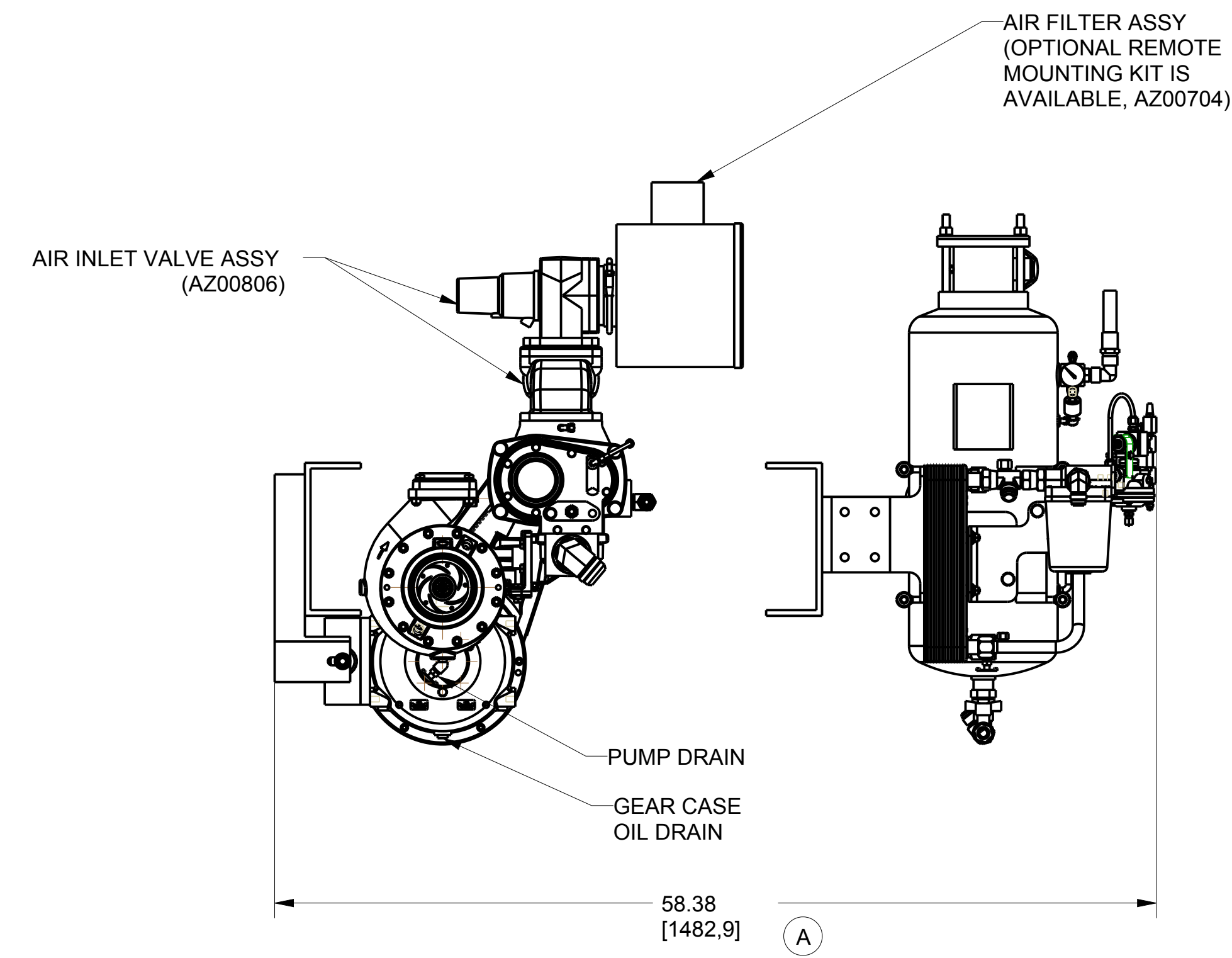
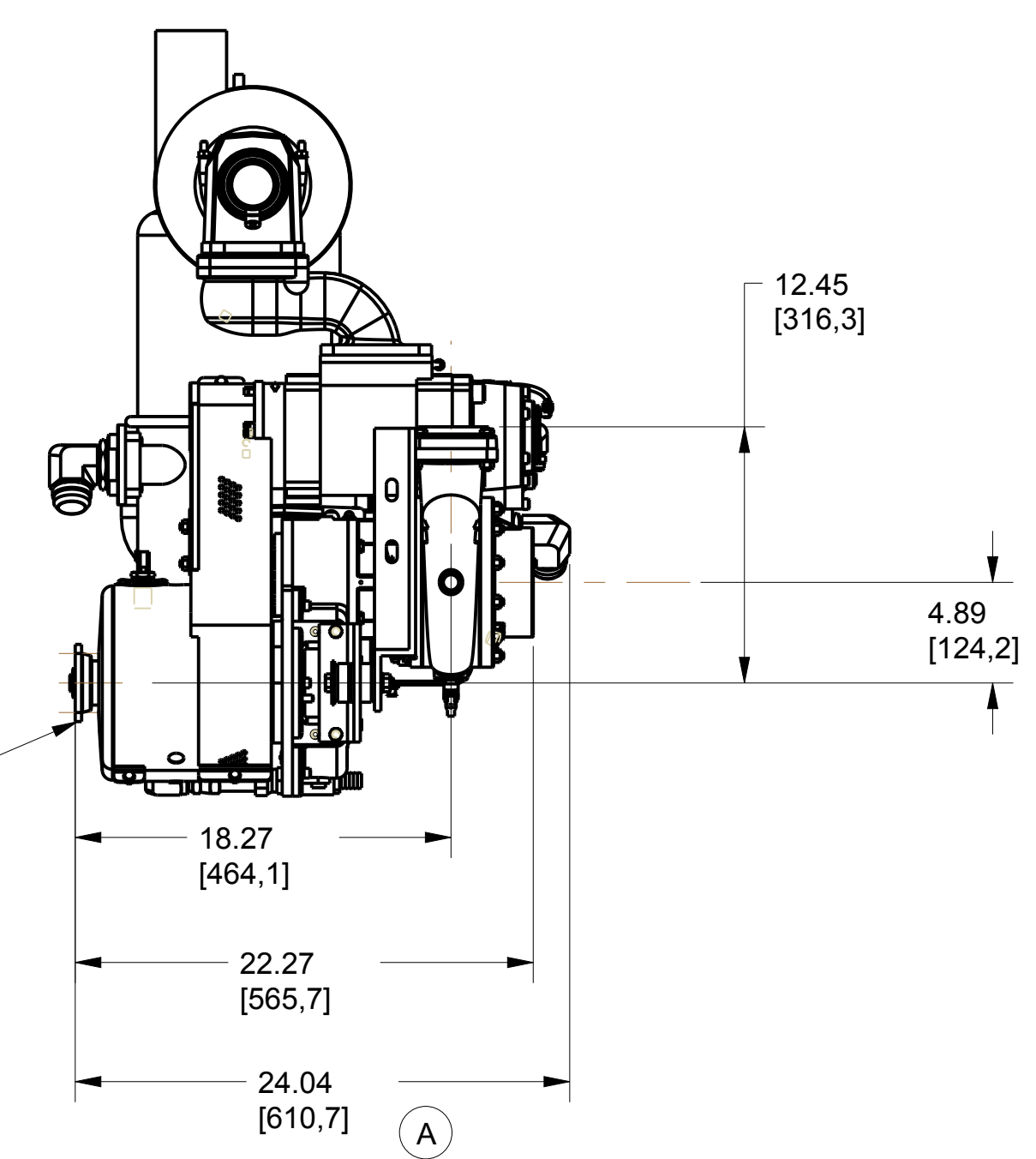

PTO DRIVE - ENGINE ROTATION ONLY

REMOVE SHARP EDGES		INCH [MILLIMETER]	OLD PART NO.	TOLERANCE EXCEPT AS NOTED	W.S. Darley & Co. ITASCA, IL - CHIPPEWA FALLS, WI
MATERIAL DESCRIPTION:	MATERIAL NO.	PATTERN NO.	00 ±.03 2000 ±.010 ANGLES ±1°	DWG - HMCB, 225 CFM INTEGRATED BELT COMP. DIM., TAMROTOR ENDURO 12TS, #1 ASSY	DATE 03/24/10
THIS DESIGN IS THE PROPERTY OF W.S. DARLEY AND CO. - UNAUTHORIZED REPRODUCTION IS PROHIBITED	ALL DIMENSIONS IN INCHES UNLESS NOTED	DO NOT SCALE PRINT	DRY RJG CHKD MCR TRCD	SCALE 1/8	DHD2140

MODEL NAME: DHD2140
MFL CREATED: 03/24/10
SHEET: 1/1