

REVISIONS				
LTR	DESCRIPTION	DATE	CHG NO.	APPRD

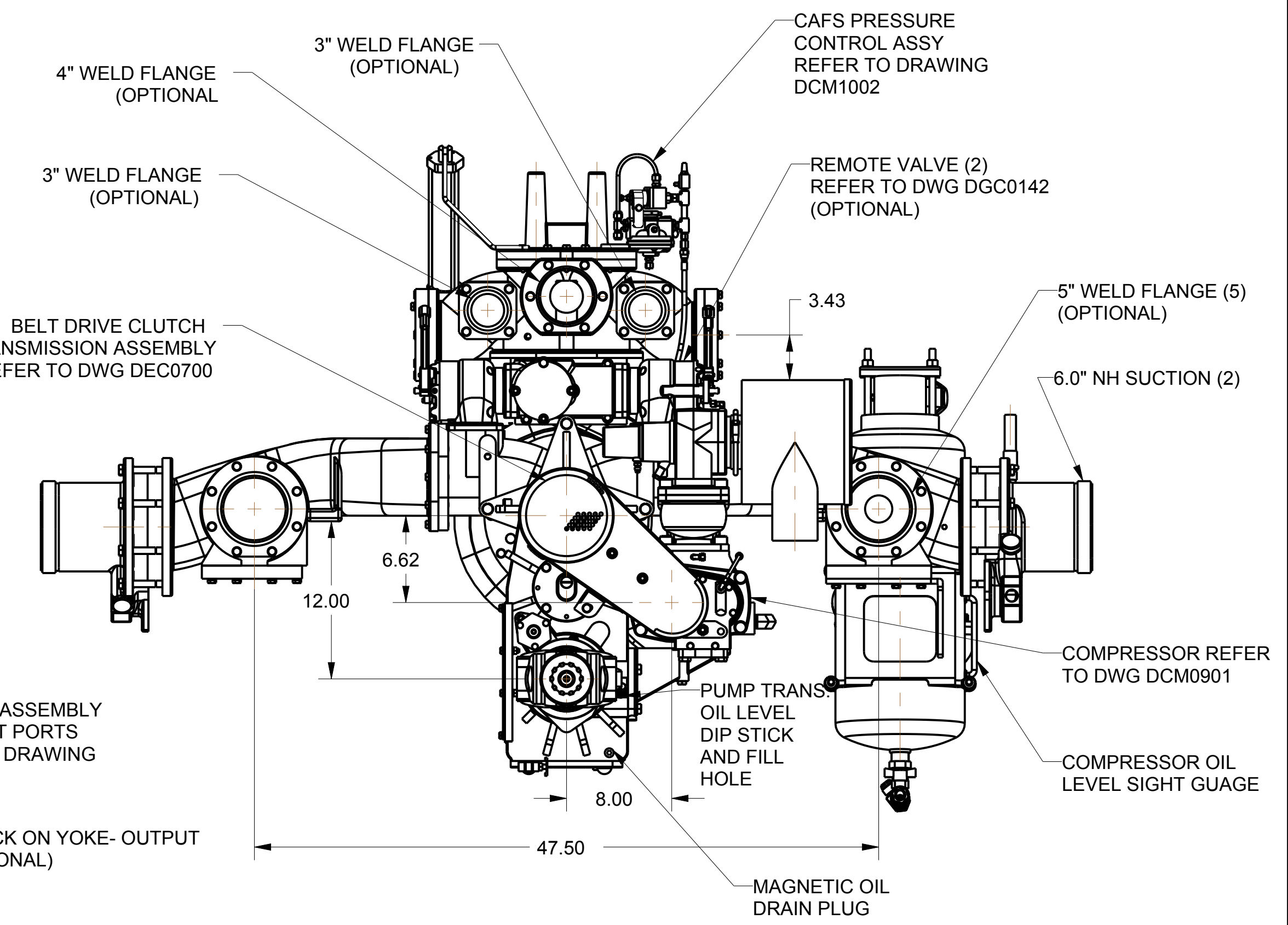
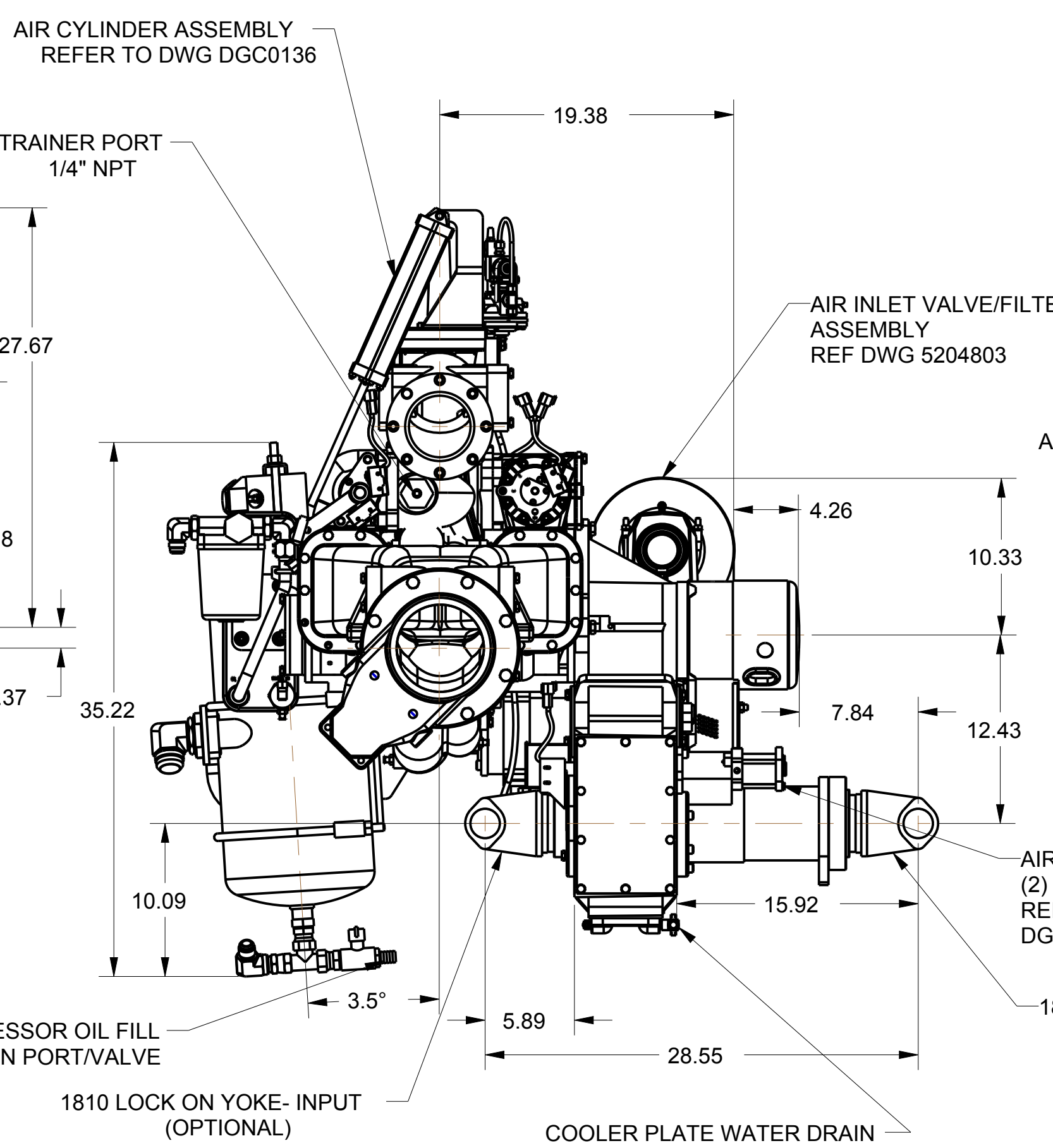
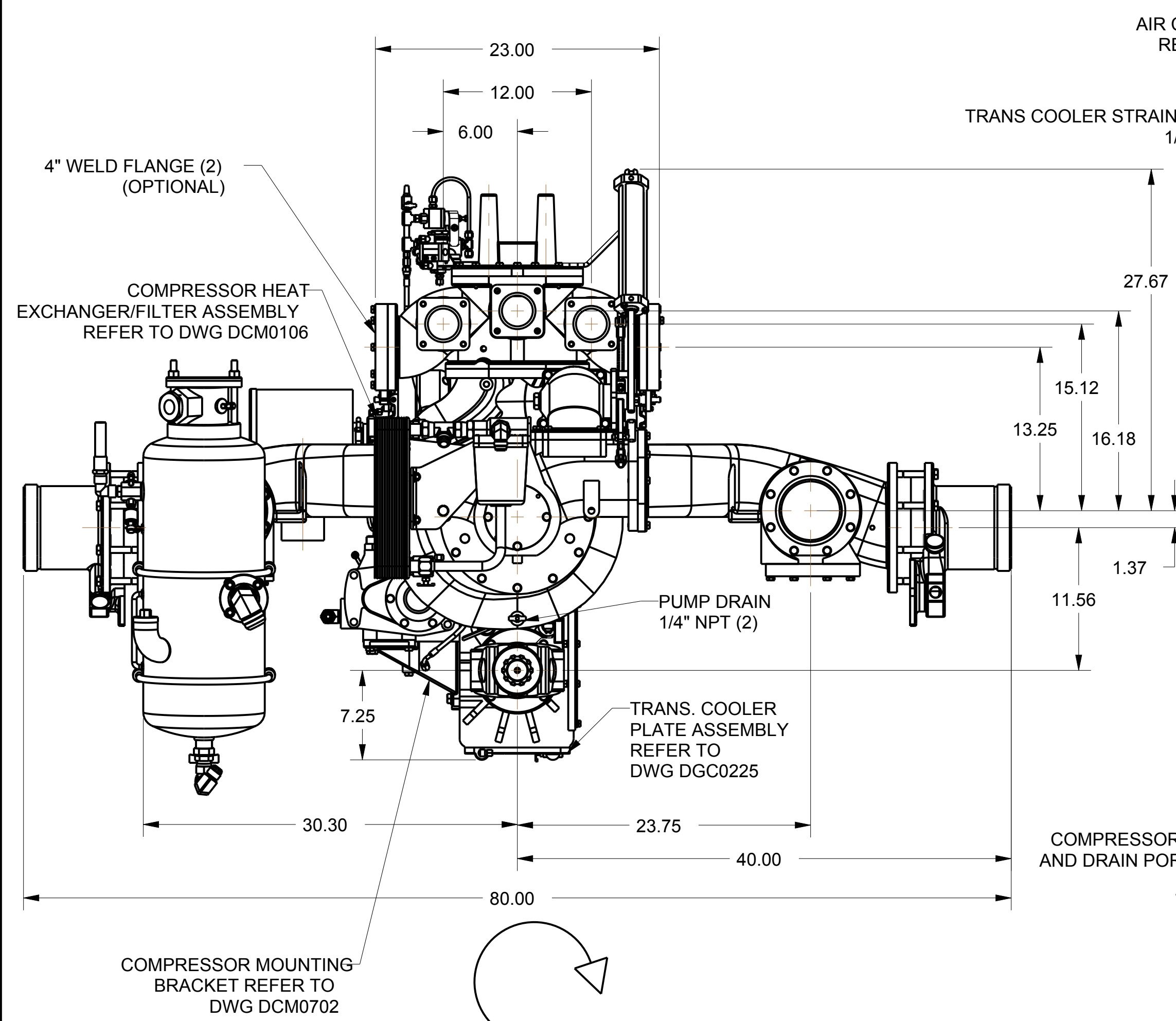
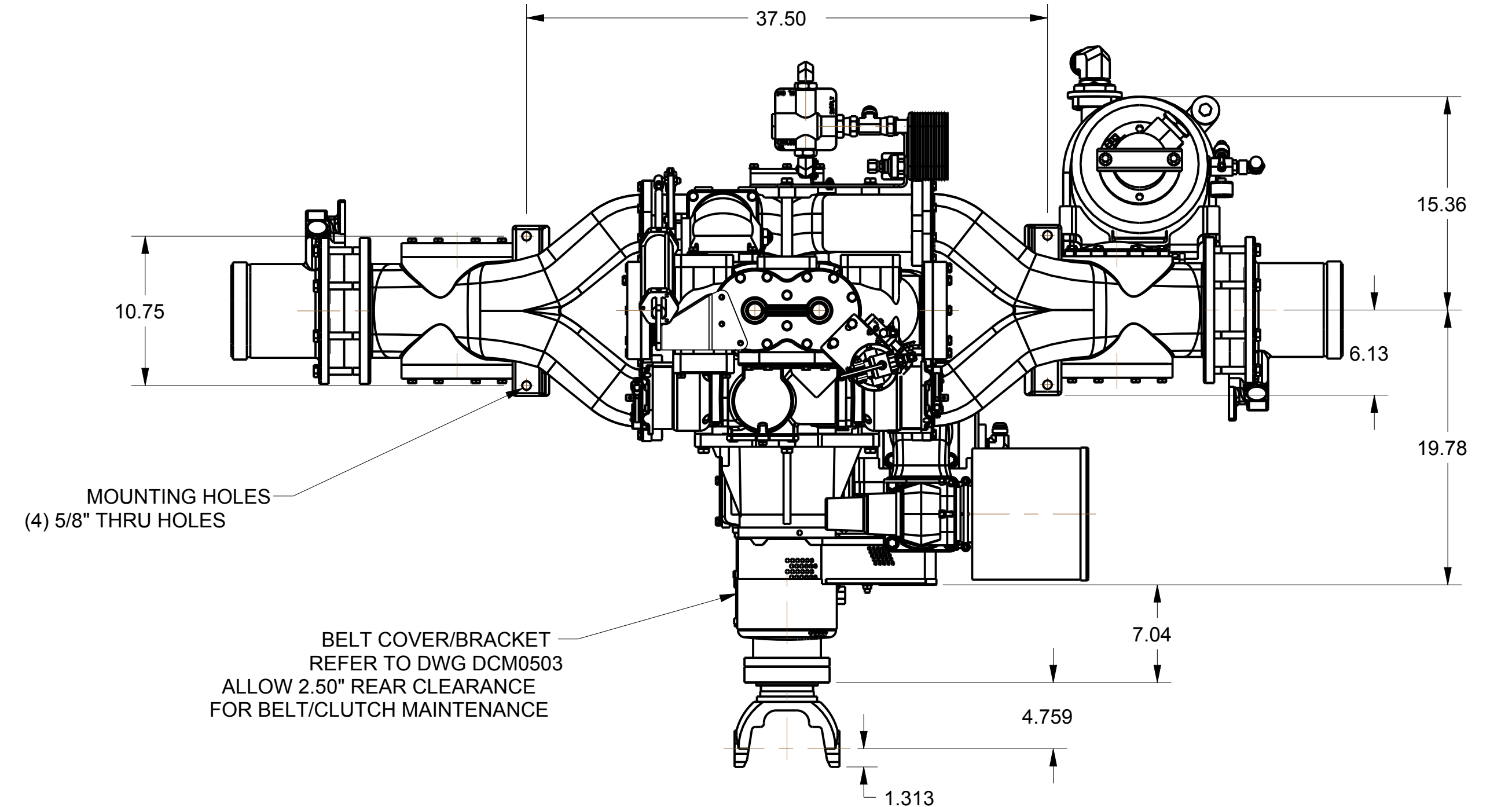
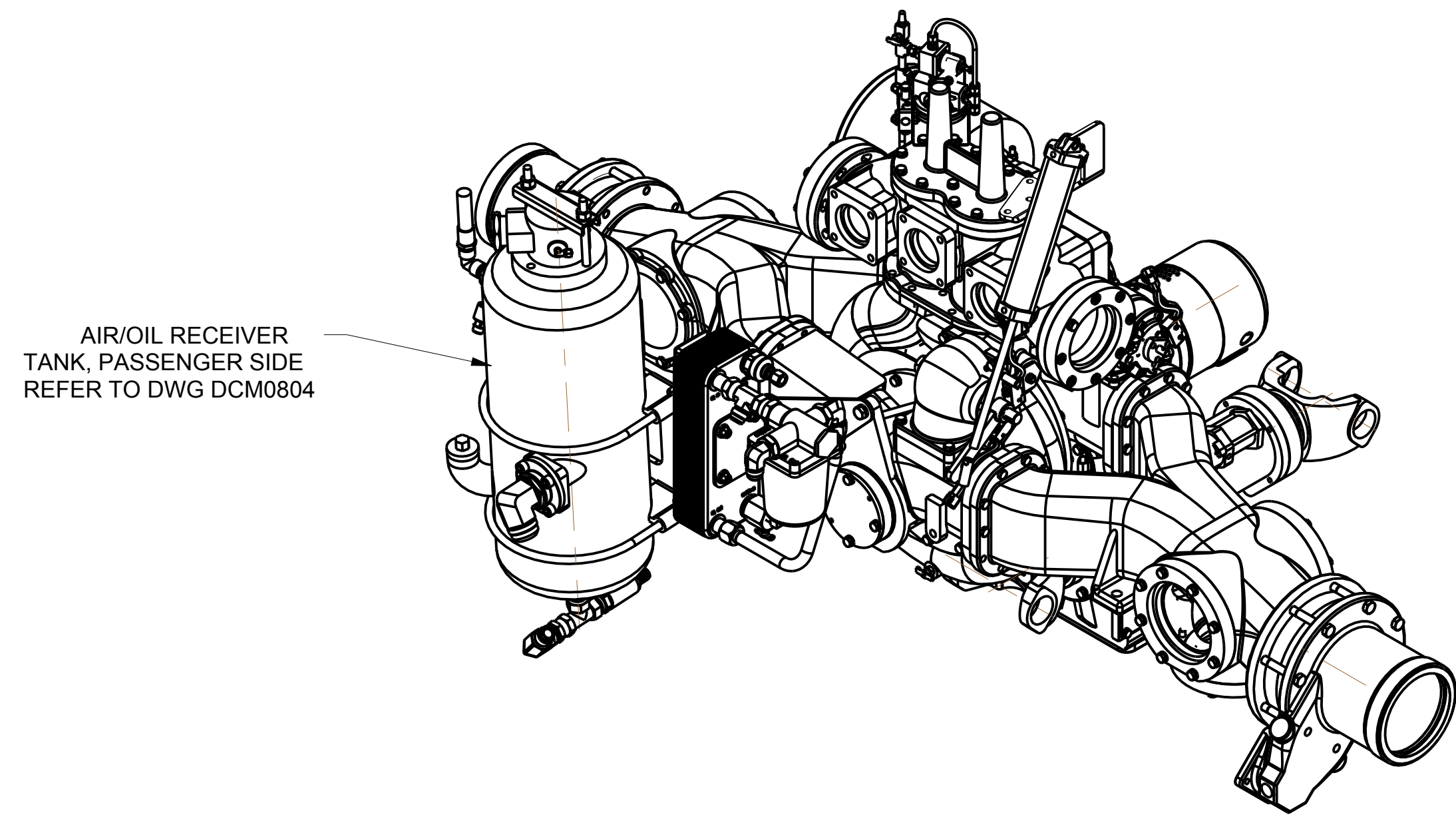

CLOCKWISE ENGINE ROTATION
WHEN FACING PUMP FROM
FRONT OF TRUCK

REMOVE SHARP EDGES		INCH (MILLIMETER)		OLD PART NO.		TOLERANCE EXCEPT AS NOTED		W.S. Darley & Co. ITASCA, IL - CHIPPEWA FALLS, WI	
MATERIAL DESCRIPTION:		MATERIAL NO.		PATTERN NO.		DWG - EMBC 1500/2000, FWD DIMENSIONAL		DATE 11-Apr-12	
THIS DESIGN IS THE PROPERTY OF W.S. DARLEY AND CO. - UNAUTHORIZED REPRODUCTION IS PROHIBITED		ALL DIMENSIONS IN INCHES UNLESS NOTED		DO NOT SCALE PRINT		DRN KMD		SCALE 1/16	
								DED0011	