

REVISIONS				
LTR	DESCRIPTION	DATE	CHG NO.	APPR'D

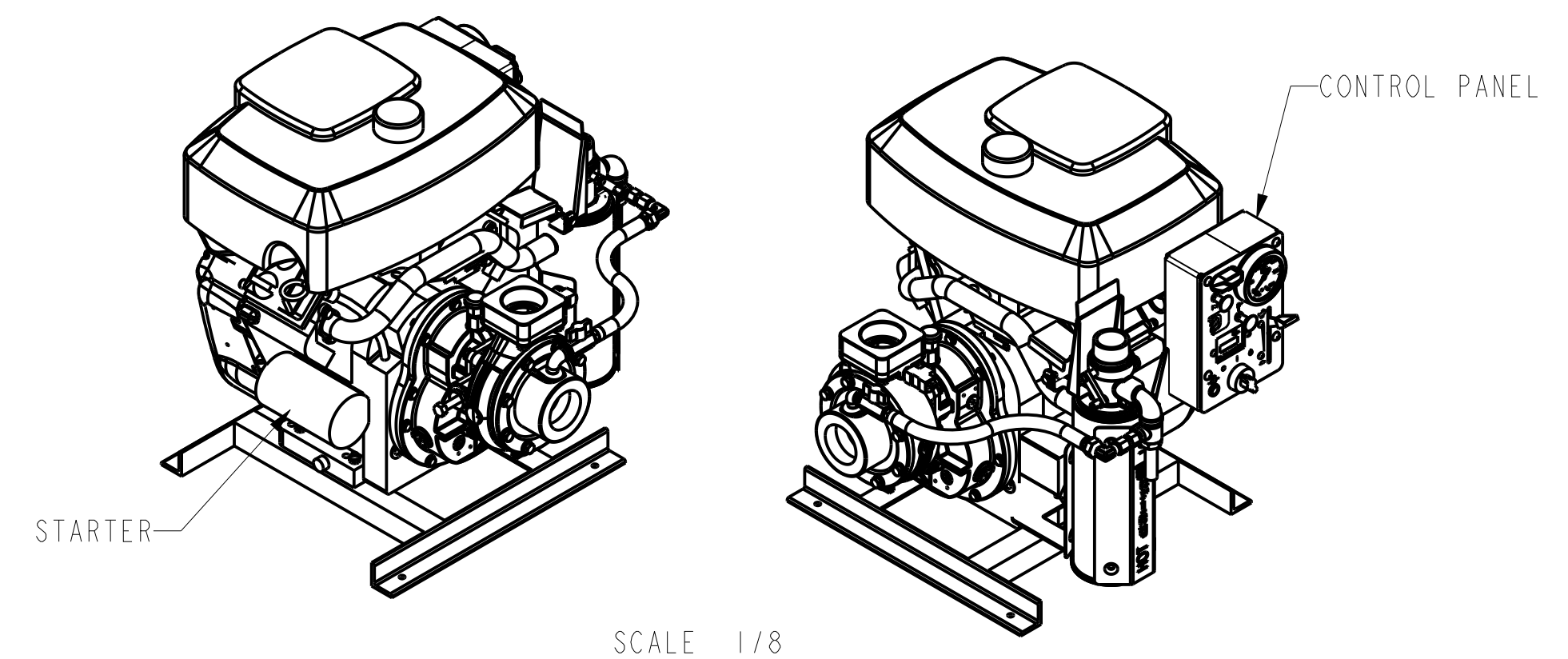

SCALE 1/8

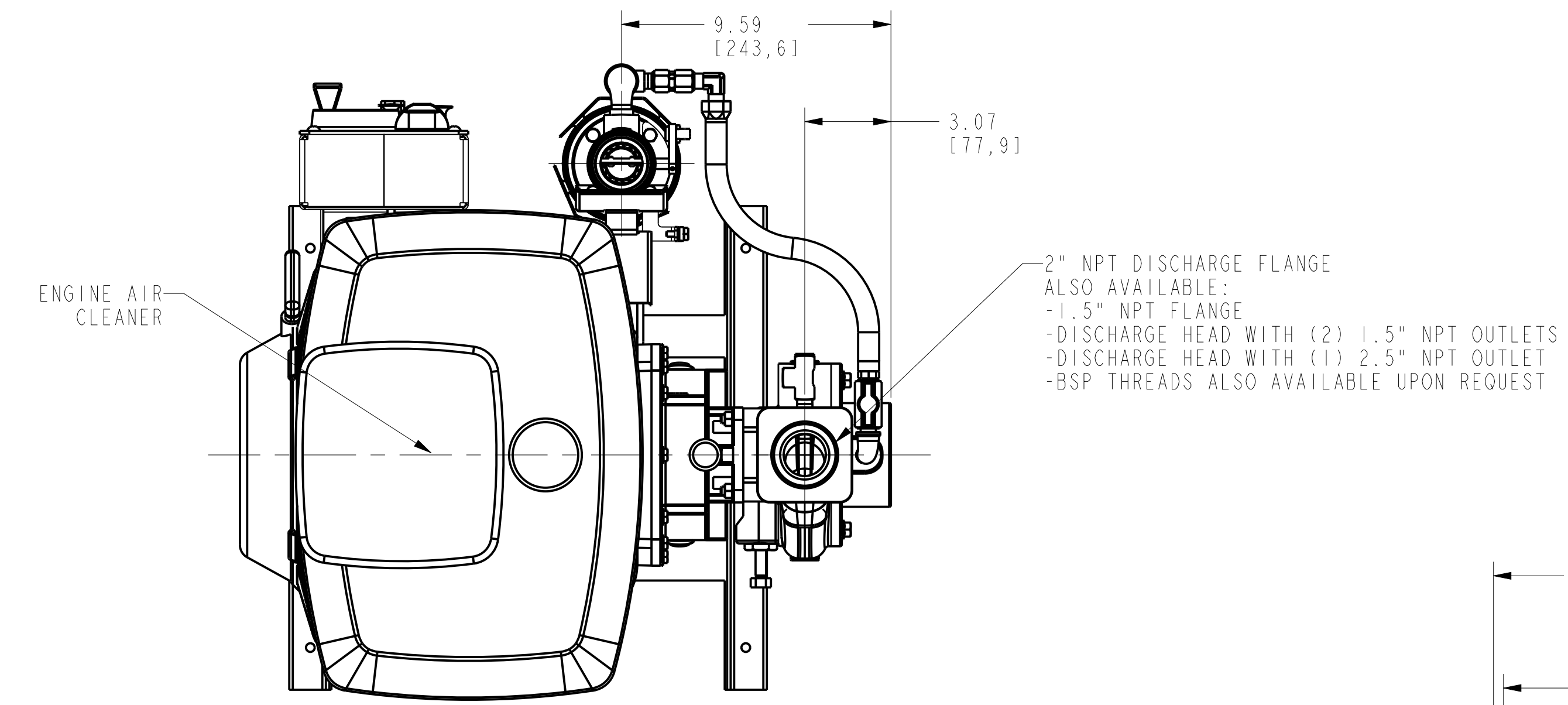

2" NPT DISCHARGE FLANGE
ALSO AVAILABLE:
- 1.5" NPT FLANGE
- DISCHARGE HEAD WITH (2) 1.5" NPT OUTLETS
- DISCHARGE HEAD WITH (1) 2.5" NPT OUTLET
- BSP THREADS ALSO AVAILABLE UPON REQUEST

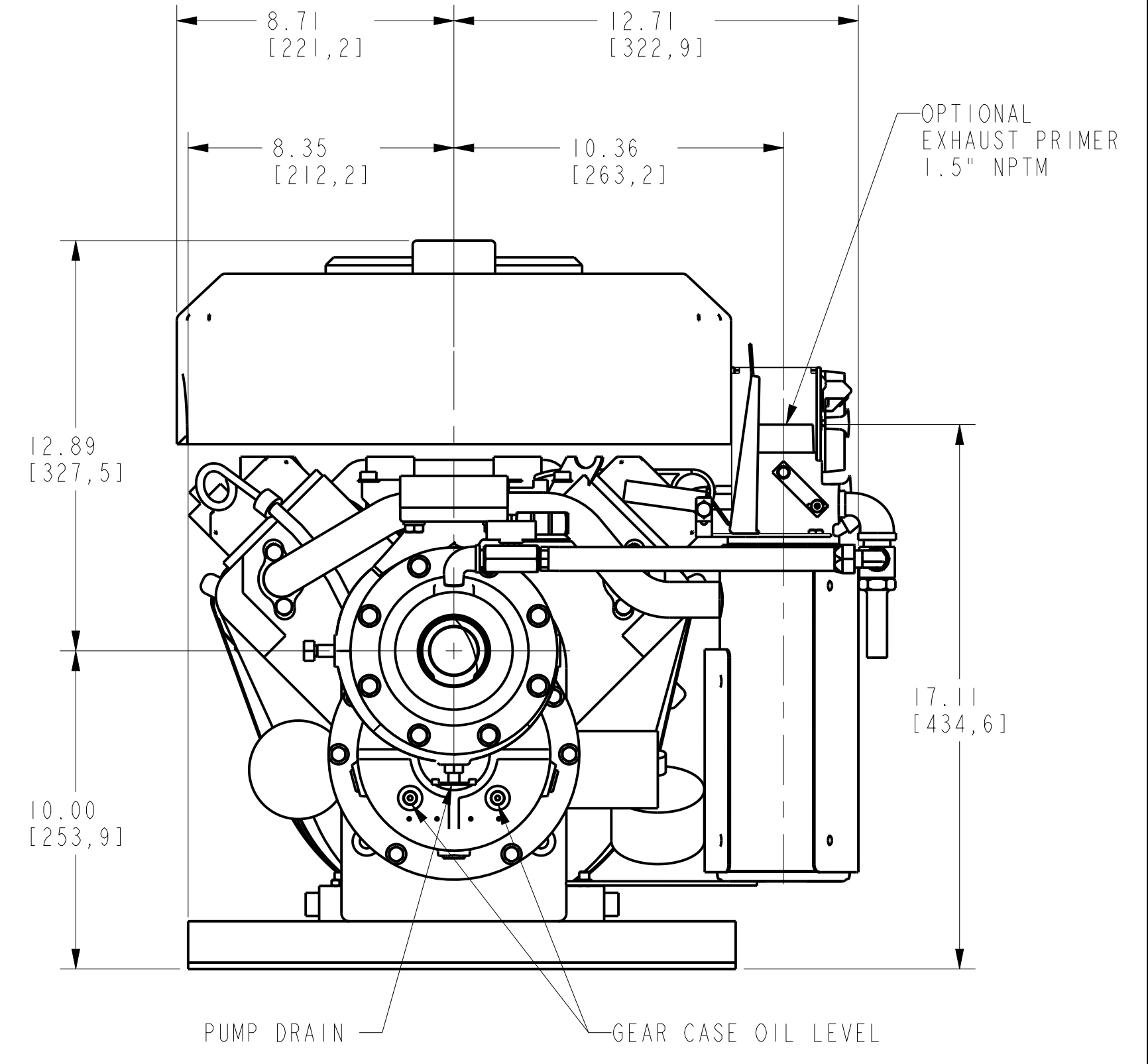
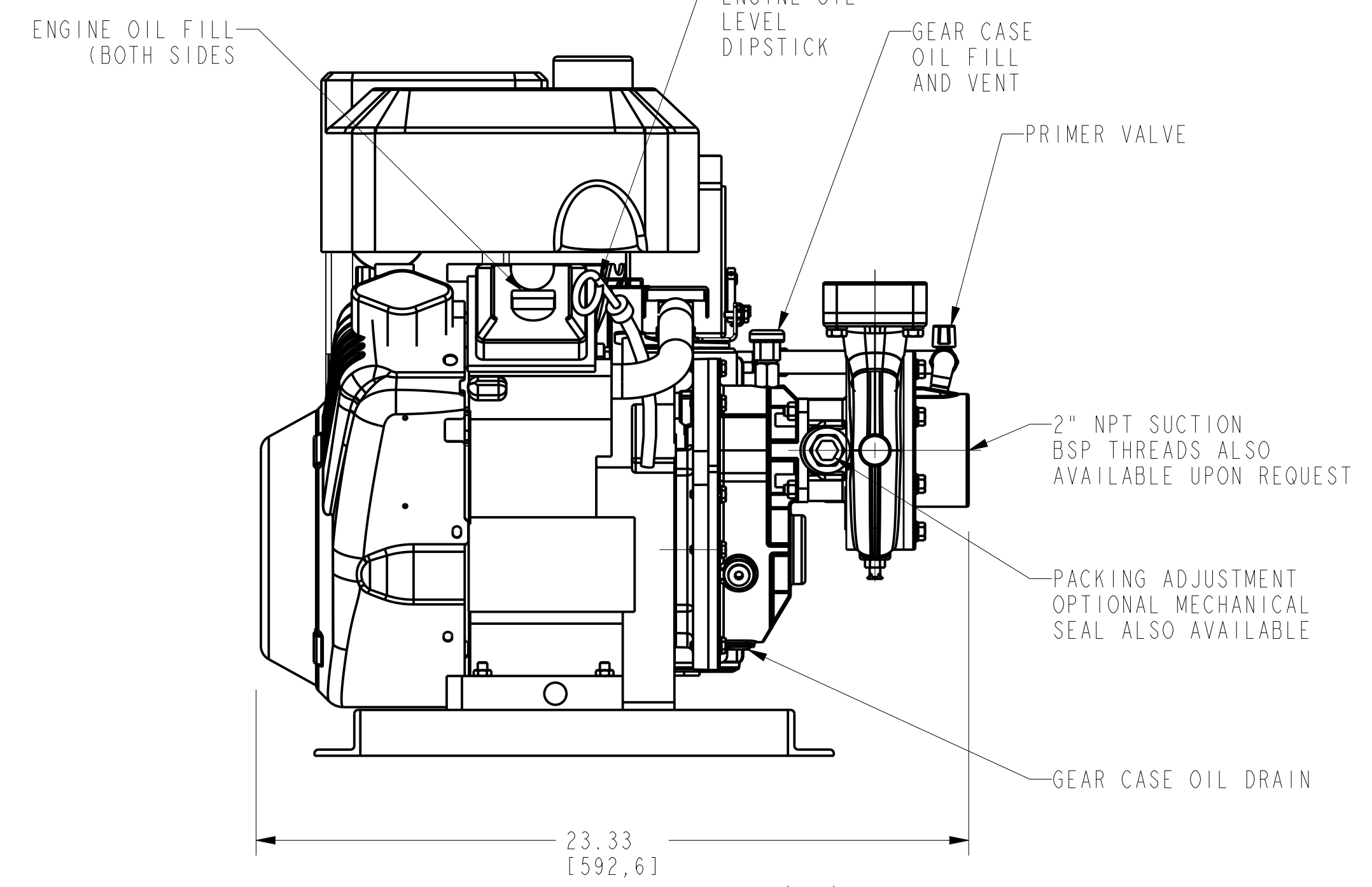
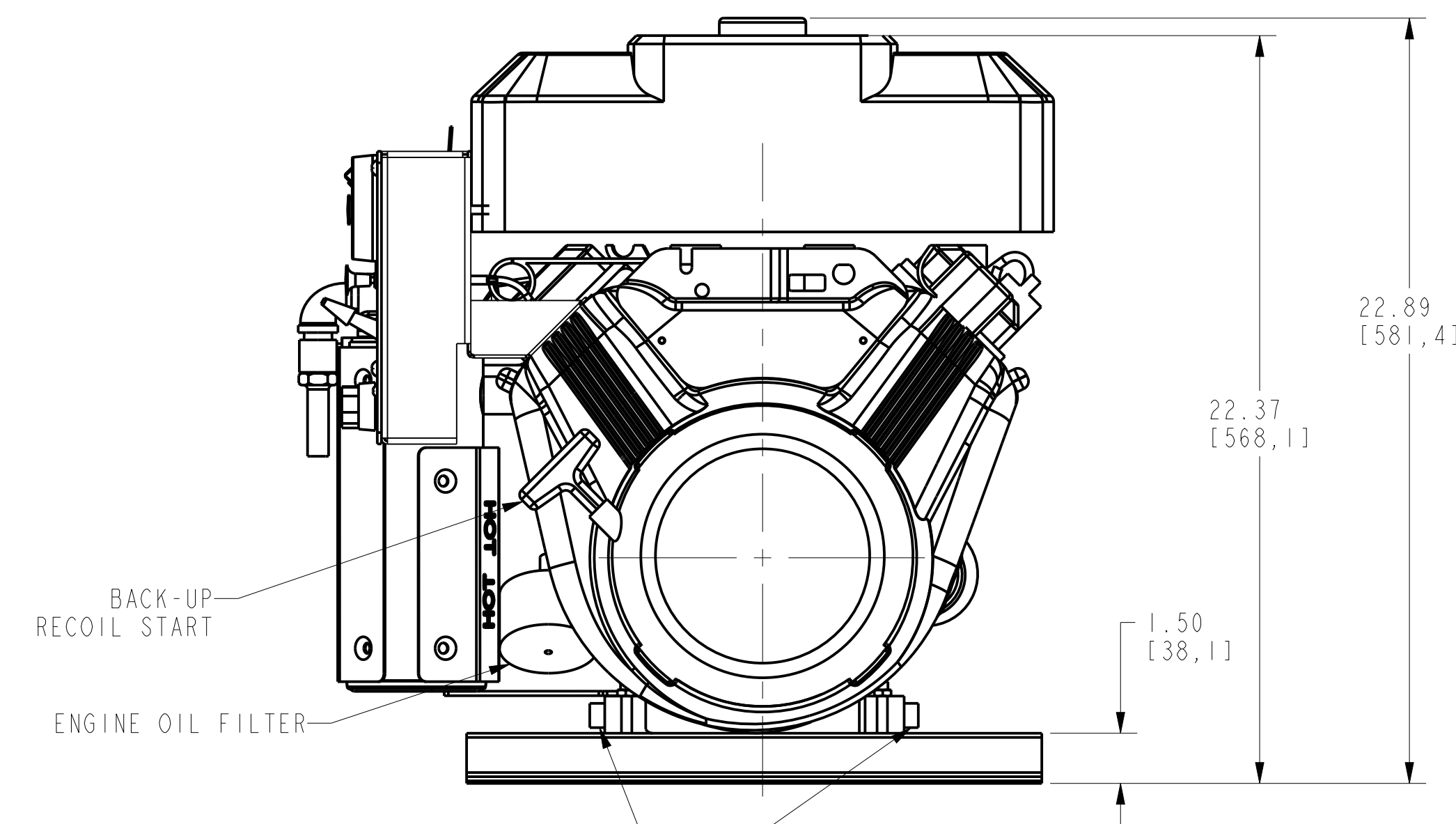

APPROXIMATE WEIGHT: 146 LBS (66 KG)

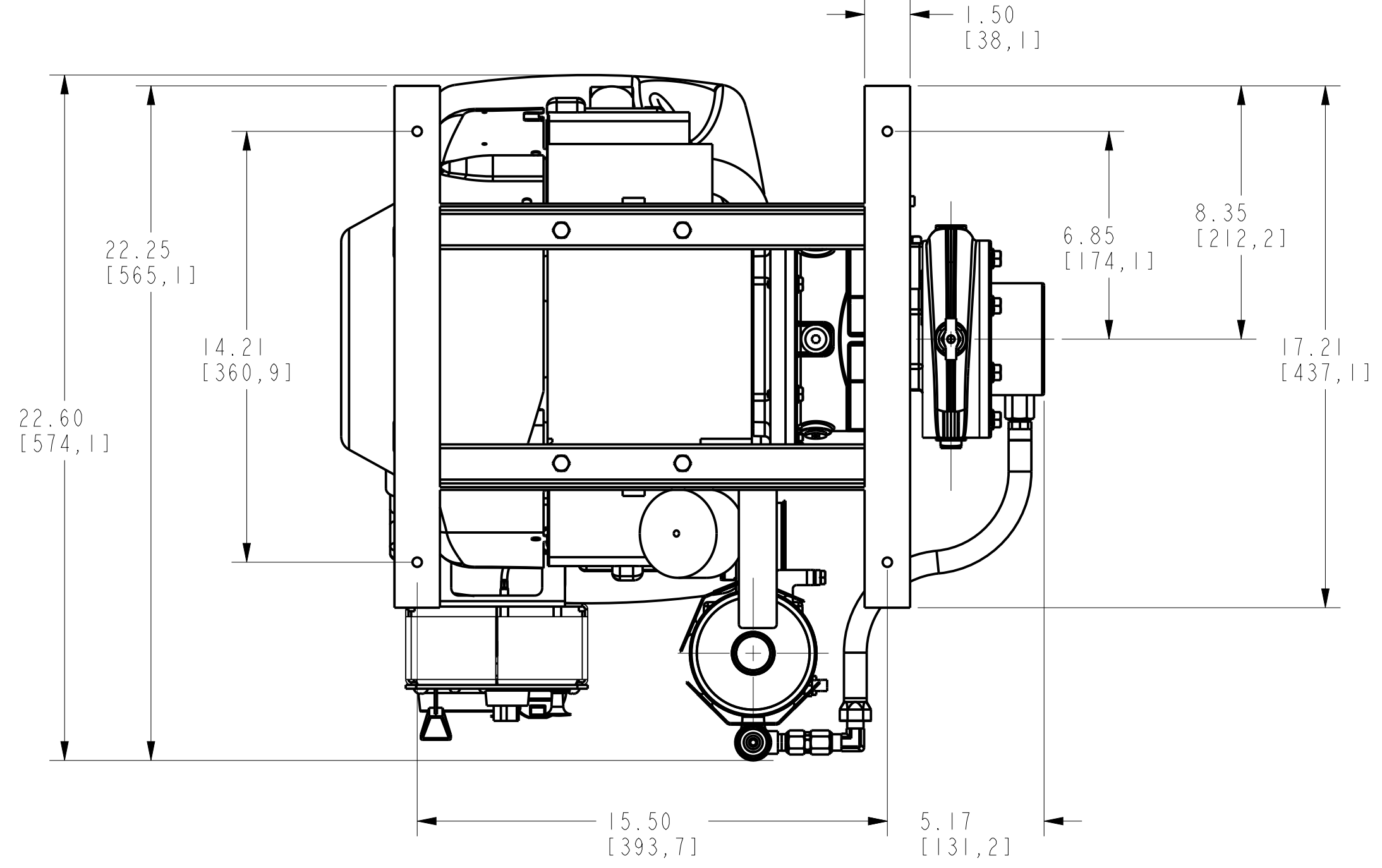
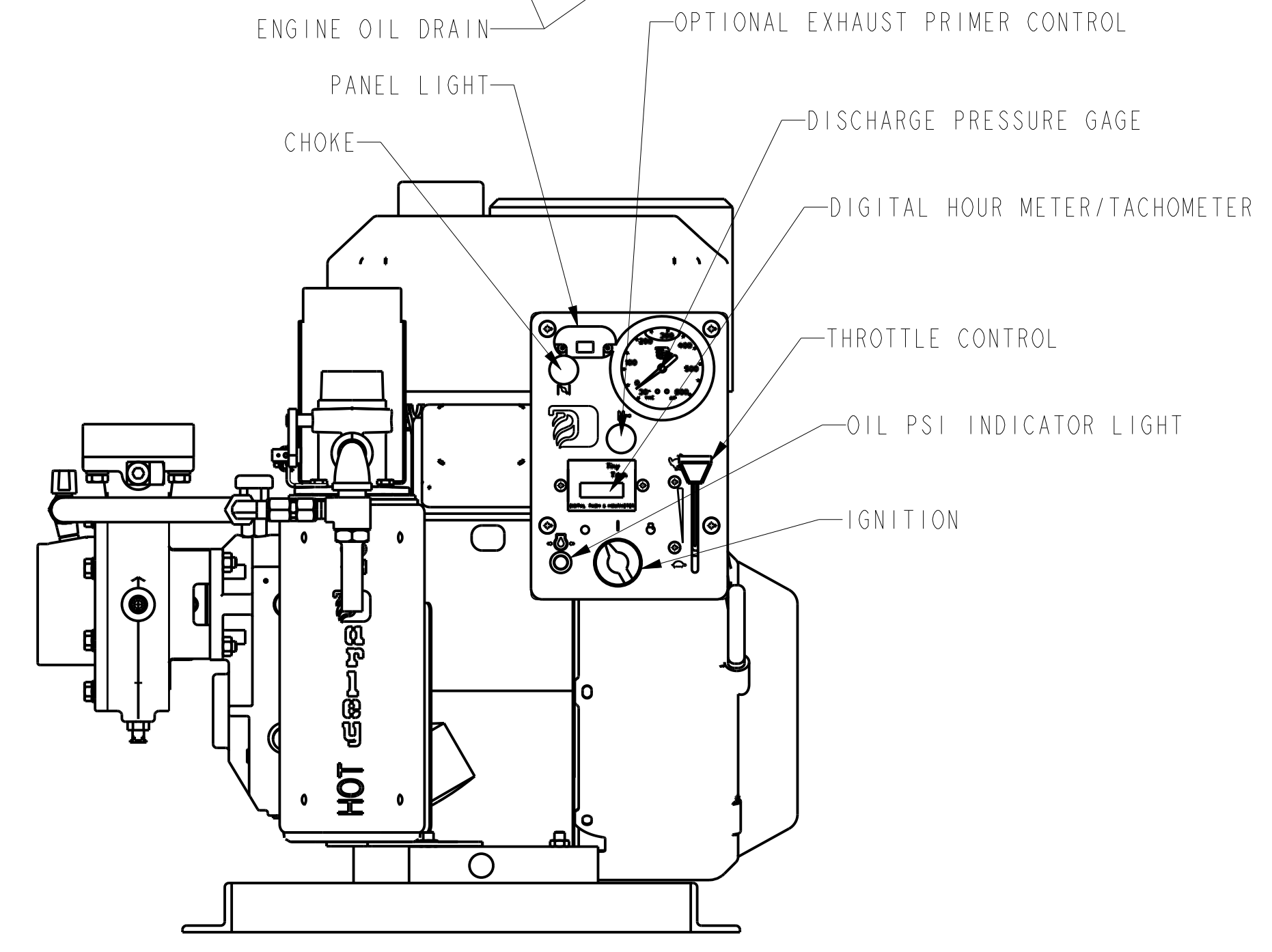

REMOVE SHARP EDGES		INCH (MILLIMETER)	OLD PART NO.	TOLERANCE EXCEPT AS NOTED	W.S. Darley & Co. ITASCA, IL - CHIPPEWA FALLS, WI
MATERIAL DESCRIPTION: ALUMINUM	MATERIAL NO.	PATTERN NO.	00 ±.03 .000 ±.010 ANGLES ±1°	DWG - 1.5AGE, 18HP VAN. SKID FUEL TANK, CONTROL	DR'N TED CHWD AAN TRCD
THIS DESIGN IS THE PROPERTY OF W.S. DARLEY AND CO. - UNAUTHORIZED REPRODUCTION IS PROHIBITED		ALL DIMENSIONS IN INCHES UNLESS NOTED		DATE 4-Dec-13 SCALE 1/4	DAD0713

MODEL NAME: DAD0713
MOL CREATED: 4DEC2013
SHEET: 1/1