

DARLEY FAST FOAM 150

CLASS “A” FOAM PROPORTIONER¹

MOTOR and PUMP

The motor is a 12 VDC, ½ hp continuous speed electric motor.. The pump is a continuous duty, piston type, positive displacement pump. The pump is rated at 1.5 gpm. The pump shall be supplied with a 400 psi safety relief valve for protection against over pressurization. The Venturi will flow up to 150 gpm.

PILOT OPERATED RELIEF VALVE

This simple non-electronic device is the key to reliable repeatable and safe operation. The PORV controls the foam concentrate flow path by diverting the excess foam concentrate, not utilized in the injection process, back to the foam concentrate tank. The PORV takes a water pressure signal from the main waterway and shifts the valve mechanically to control the system.

CONTROL PANEL

The control panel consists of a placard with operating instructions, low concentrate level warning light, on/off power switch and fully adjustable concentrate metering valve. This metering valve is infinitely adjustable from 0% to 1%.

SAFETY INTERLOCKS

The system shall have a water pressure switch that prevents the unit from operating in the absence of water pressure. The system shall be provided with a foam concentrate low-level float switch. The float switch will turn off the system when the foam concentrate level is low. The system shall be provided with a momentary interlock override switch.

SYSTEM COMPONENTS

1. Pump unit (assembled)
 - a) 12 VDC motor
 - b) 1.5 gpm Piston Pump
 - c) Pilot Operated Relief Valve
 - d) Pressure Relief Safety Valve
 - e) Water Pressure Switch
 - f) Circuit Breaker
 - g) Control Relays
 - h) Momentary Interlock Override switch
 - i) Concentrate Injection Check Valve
 - j) Water resistant Electric Connection Plugs
 - k) Three-Way Flush Valve
2. System Controller
 - a) Panel Mount Placard with Operating Instructions
 - b) Low Concentrate Warning Light
 - c) On/Off Switch
 - d) Proportioning Valve
 - e) Wiring Harness
3. Master Check Valve
4. Injection Venturi
5. Low Concentrate Float Switch with Wiring Harness
6. One (1) Printed Instruction Manual
7. One (1) Flash drive Instruction manual

¹ Specifications are subject to change and improvements without notice.

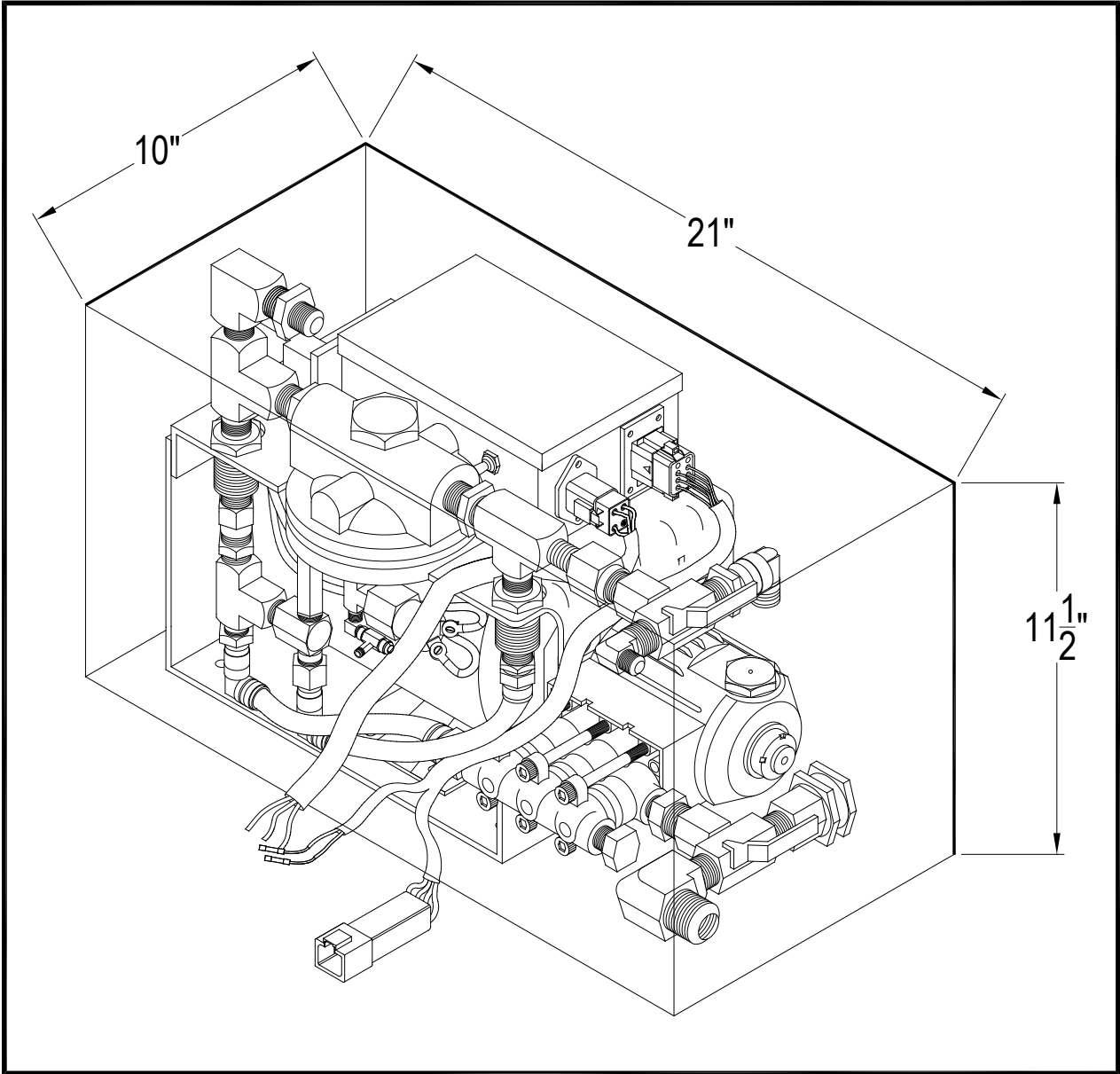

Fast Foam 150

