

REMOVE SHARP EDGES		INCH [MILLIMETER]		THIRD ANGLE PROJECTION		MODEL DAD2334		SHEET 1/2 D	
MATERIAL DESCRIPTION		MASS		MATERIAL NO.		PATTERN NO.		TOLERANCE EXCEPT AS NOTED .00 ±.03 .000 ±.010 ANGLES ±1	
394.22 LBS		394.22 LBS		CKHD JSO		TRCD		OLD PART NO.	
THIS DESIGN IS THE PROPERTY OF WS DARLEY CO. - UNAUTHORIZED REPRODUCTION IS PROHIBITED		ALL DIMENSIONS IN INCHES UNLESS NOTED		DO NOT SCALE PRINT		DATE: 2/27/2026		SCALE: 1:4	
						DWG - 2.SAGE24KUBOTA		EGOV	
								DATE: 2/27/2026	
								DAD2334	

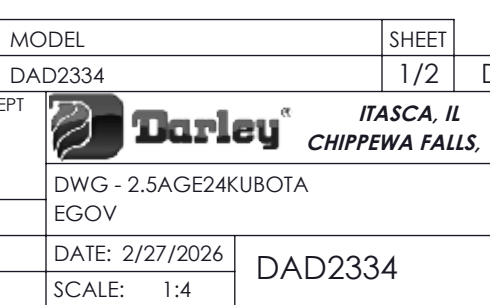

**DISCHARGE OPTIONS**

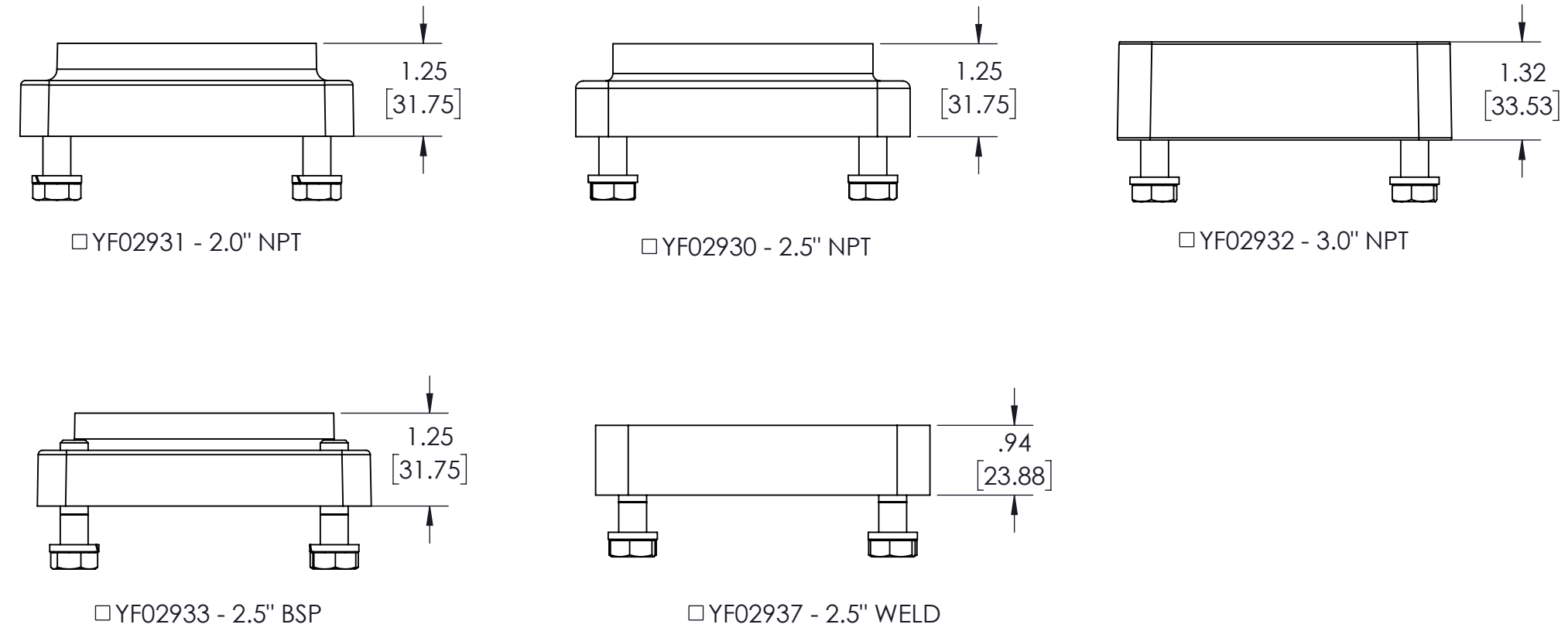

**PUMP DISCHARGE ORIENTATION**

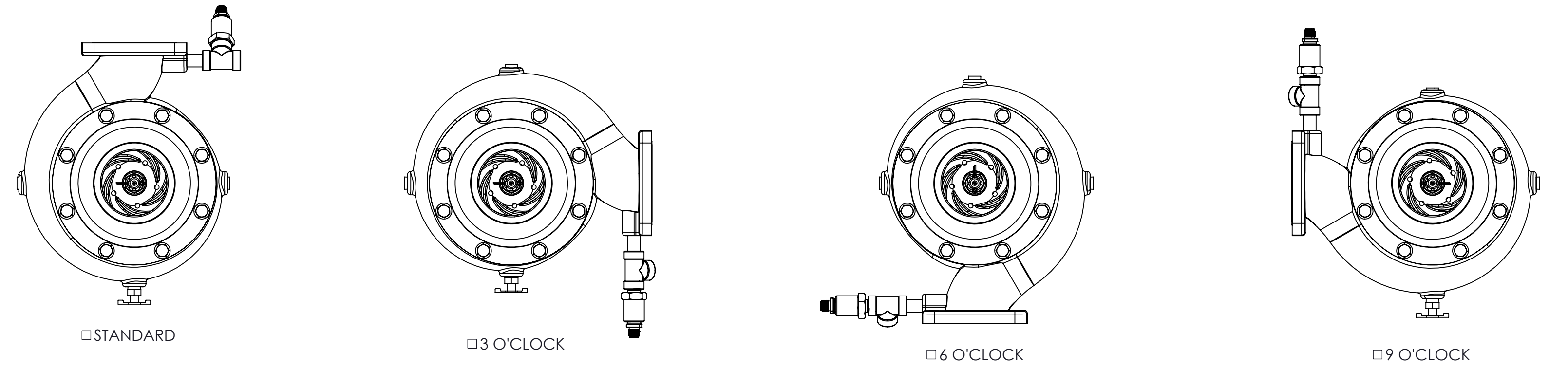

**TRANSMISSION ORIENTATION**

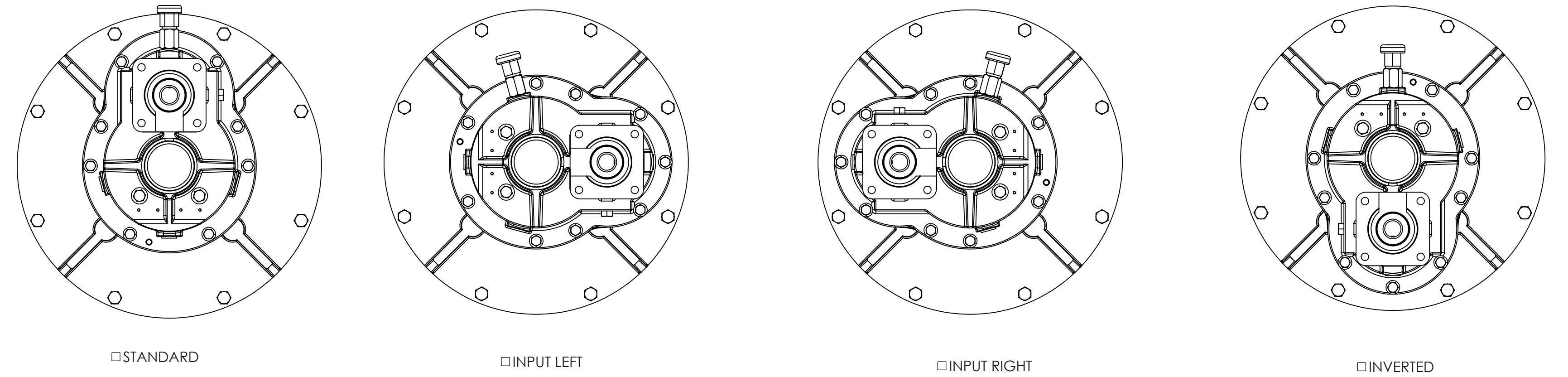

**SUCTION OPTIONS**

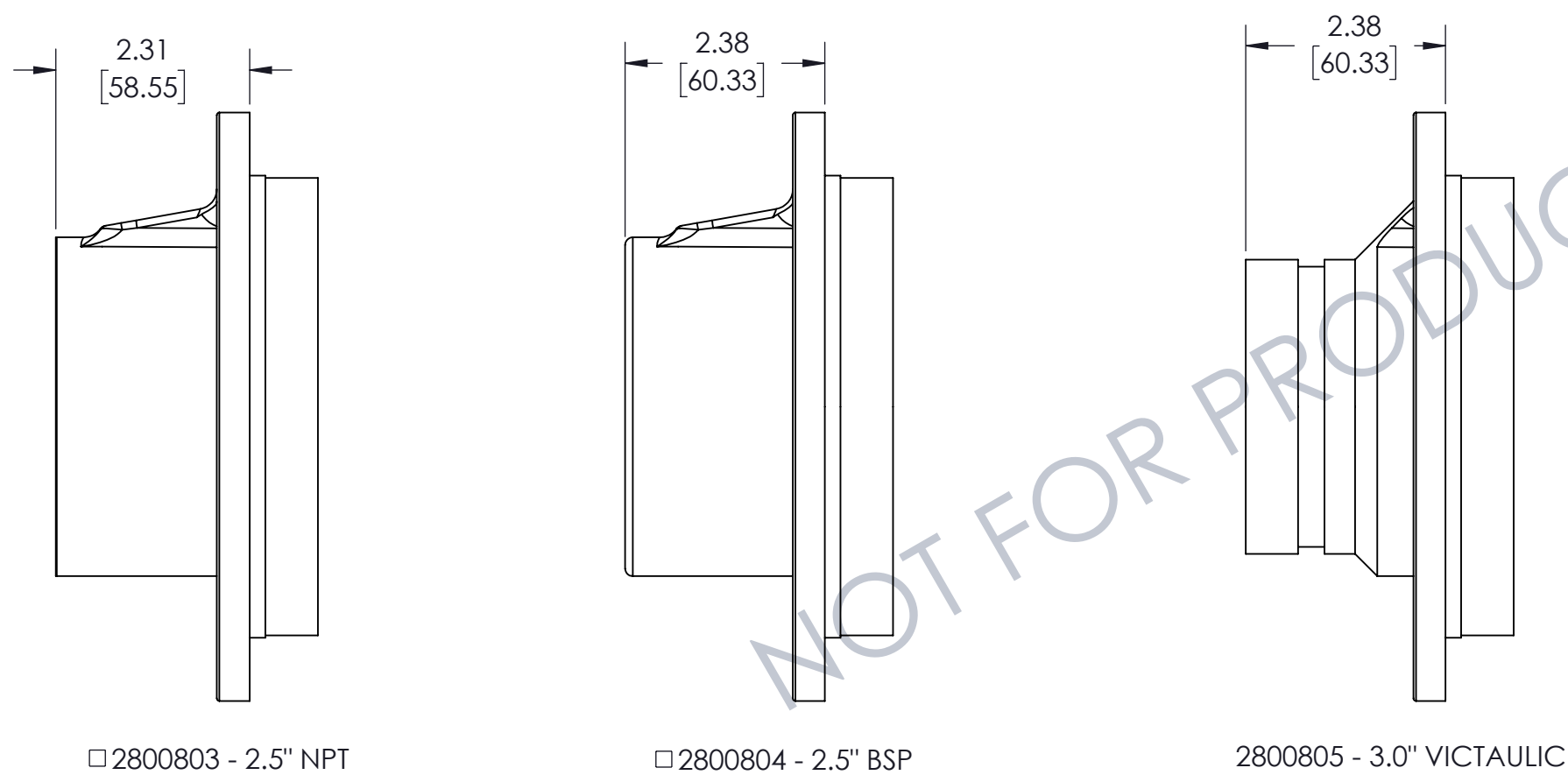

REQUIRED STANDARD ASSEMBLIES:  
 4221988 ENGINE - KUBOTA D902 EGOV - SEE DRAWING FOR ENGINE OPTIONS  
 1978321 - EPA P65 TAG  
 PA00633 - PUMP ASSEMBLY  
 TE00435 - TRANSMISSION ASSEMBLY  
 KR00114 - 1.94:1 GEAR RATIO

NOT FOR PRODUCTION SMS

THIRD ANGLE PROJECTION		MODEL	SHEET
		YF02930X	2/2
REMOVE SHARP EDGES	INCH [MILLIMETER]	OLD PART NO.	TOLERANCE EXCEPT AS NOTED
MATERIAL DESCRIPTION	MASS	MATERIAL NO.	PATTERN NO.
	1.38 LBS		
DRWN	CLH	DATE: 11/27/2018	SCALE: 1:1
THIS DESIGN IS THE PROPERTY OF WS. DARLEY CO. - UNAUTHORIZED REPRODUCTION IS PROHIBITED		ITASCA, IL CHIPPewa FALLS, WI	
ALL DIMENSIONS IN INCHES UNLESS NOTED		DO NOT SCALE PRINT DAD2334	