

REVISIONS				
LTR	DESCRIPTION	DATE	CHG NO.	APPRD

OPTIONAL PUMP CASING POSITIONS
DISCHARGE CENTERED TO SUCTION

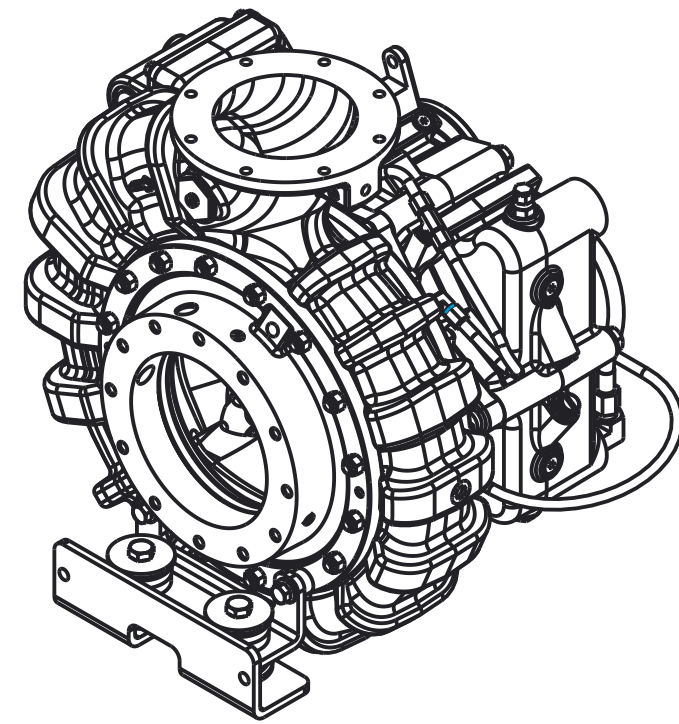

SCALE 1/8

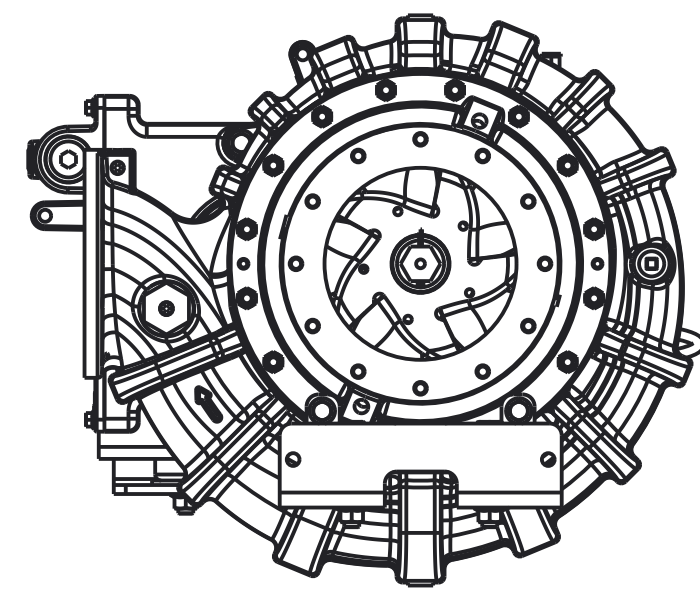

9 O'CLOCK DISCHARGE

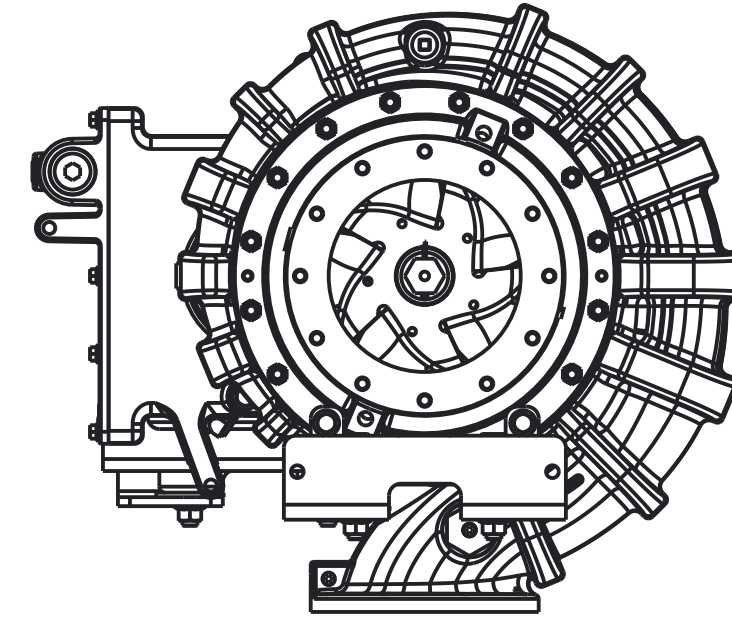

6 O'CLOCK DISCHARGE

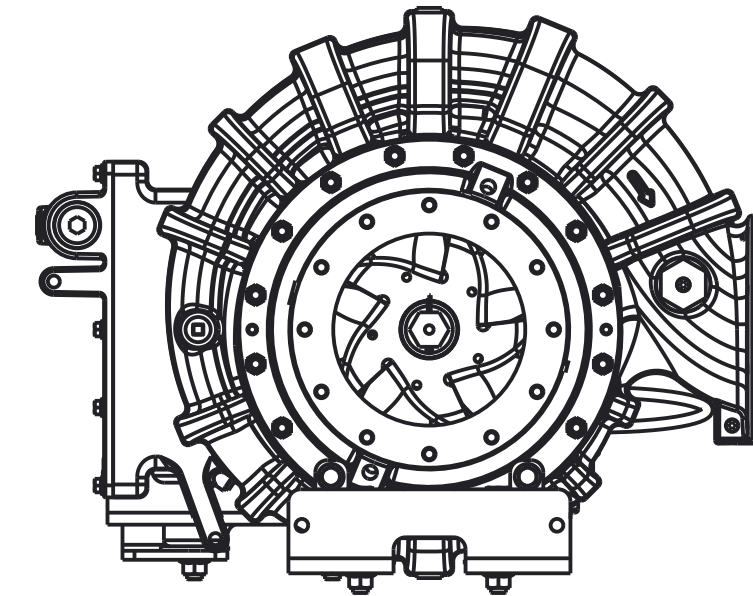

3 O'CLOCK DISCHARGE

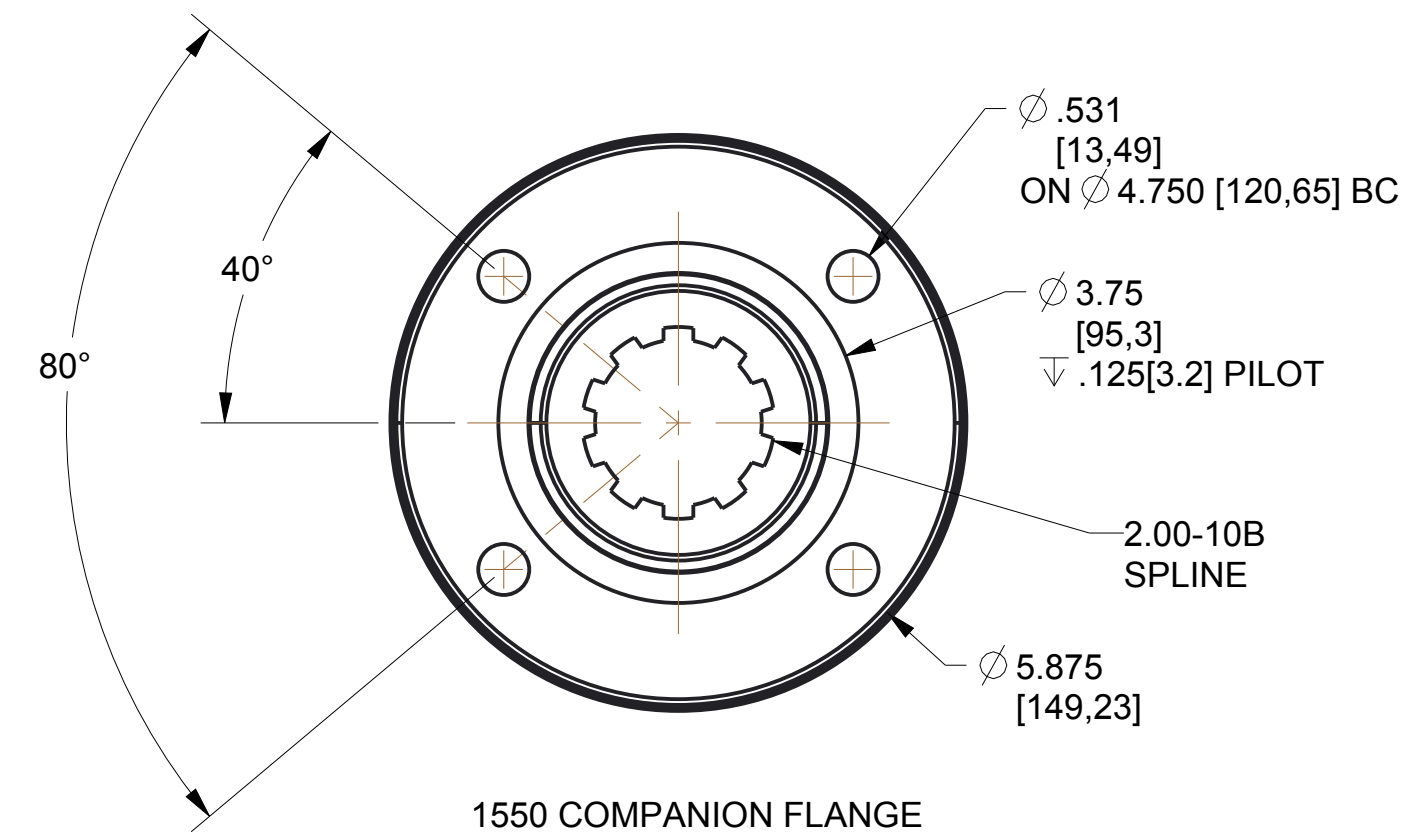

1550 COMPANION FLANGE

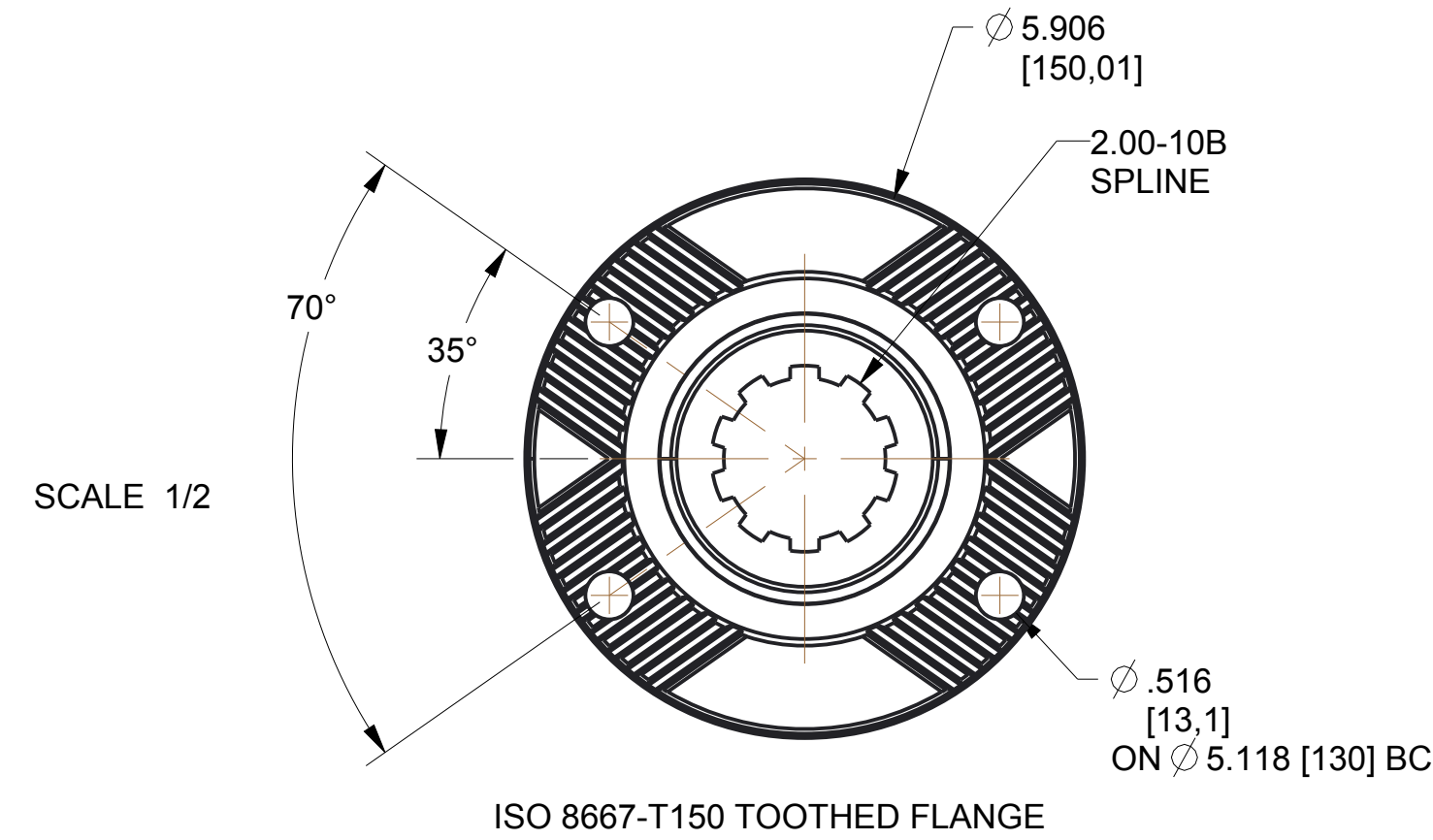

ISO 8667-T150 TOOTHED FLANGE

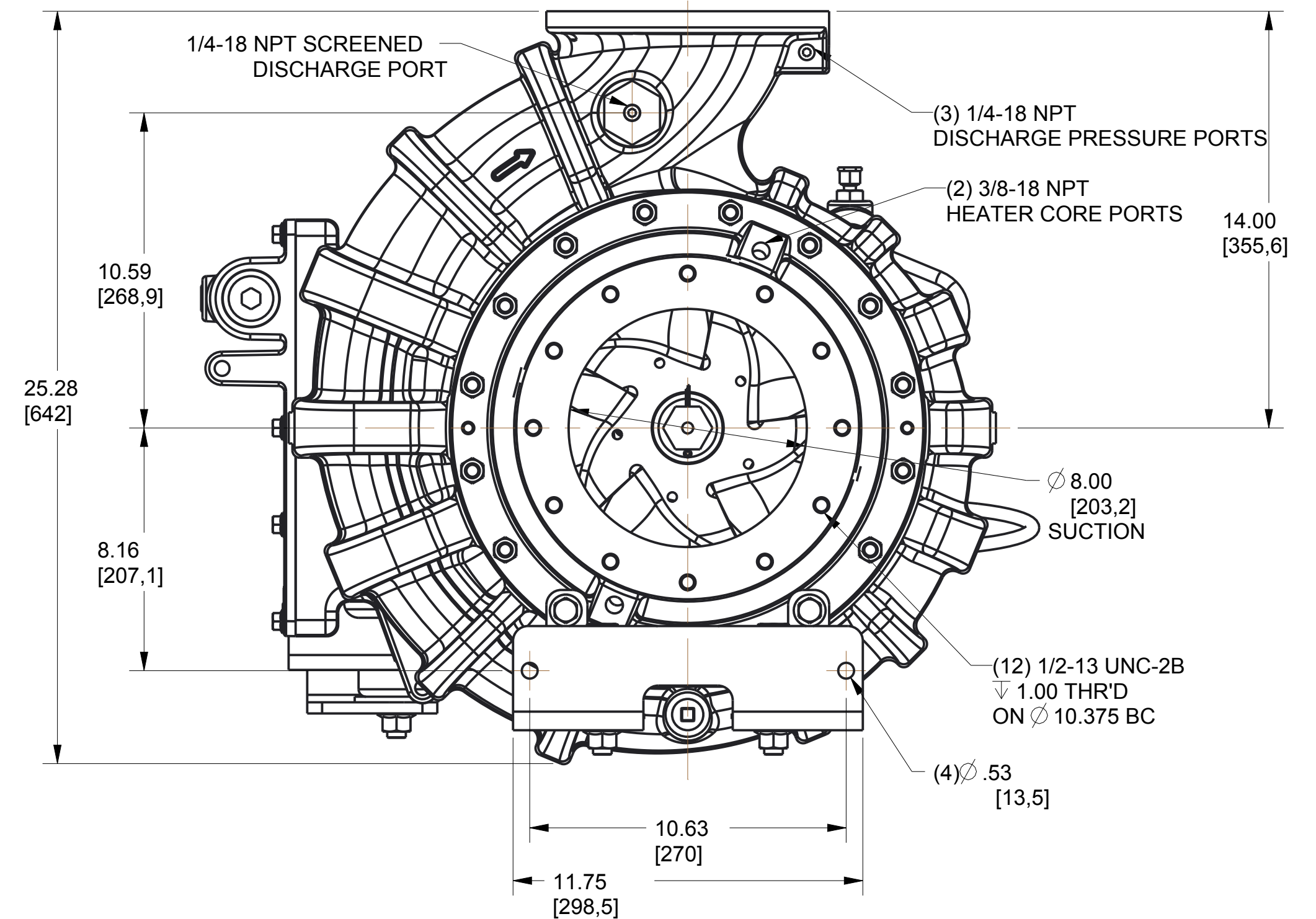
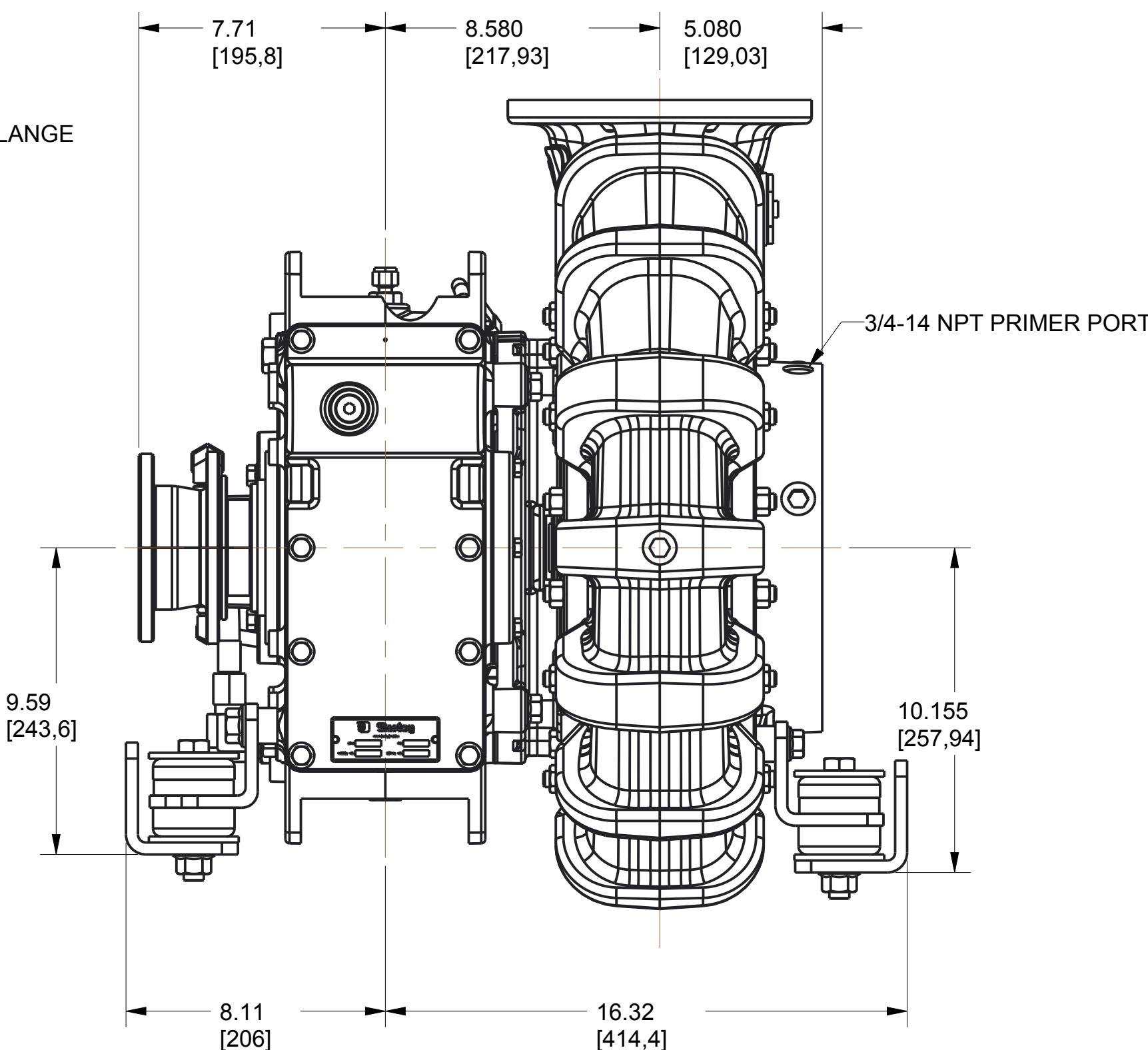
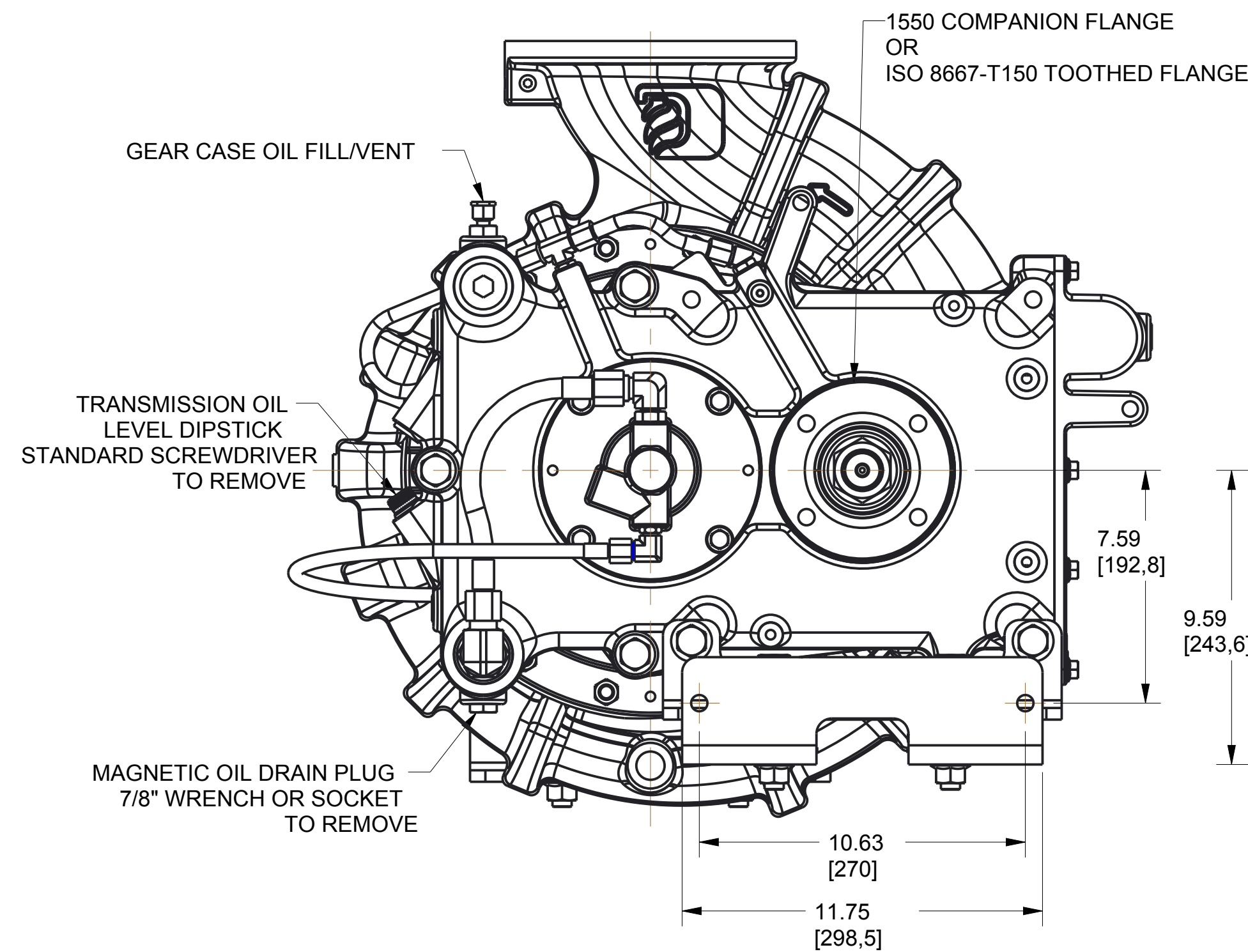
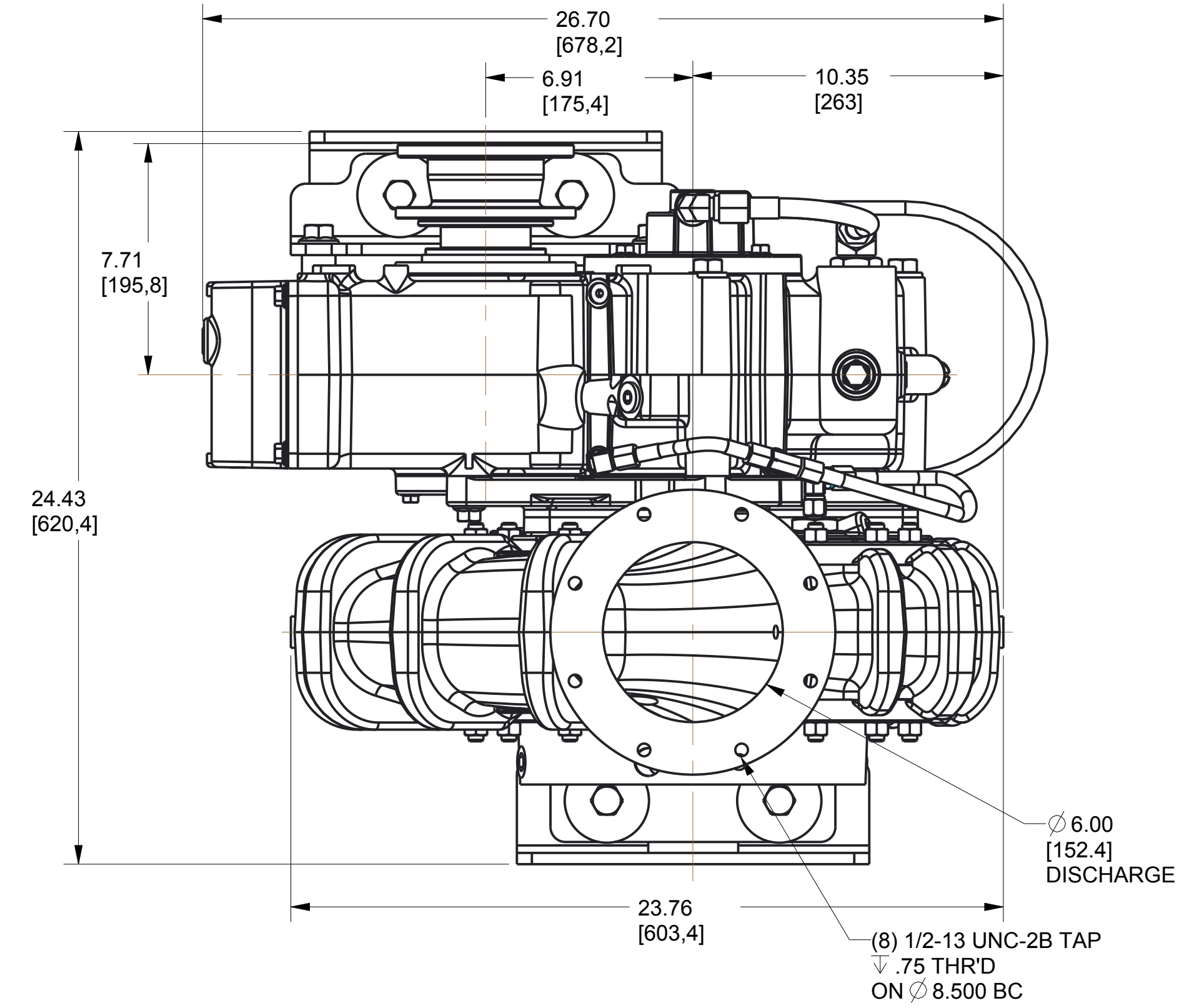

REFERENCE NOTES:
APPROXIMATE WEIGHT = 662 LB (300 KG)
PUMP SHOWN IS COMPRISED OF THE FOLLOWING ASSEMBLIES:
TRANSMISSION - TP01921
PUMP - PZ00001 (FRESH WATER)
IMPELLER - 2908600 (ENGINE ROTATION DRIVE SOURCE - ER)
TRANSMISSION MOUNTING KIT - KM02103
SUCTION HEAD MOUNTING KIT - KM02102
GEAR RATIO - KR07306 (1.76:1) - EXTERIOR DIMENSIONS ARE THE SAME REGARDLESS OF THE GEAR RATIO USED
LOCK-ON INPUT YOKE - 4822512 (1550) OR 4822711 (T150)

REMOVE SHARP EDGES	INCH (MILLIMETER)	OLD PART NO.	TOLERANCE EXCEPT AS NOTED 00 ±.03 2000 ±.010 ANGLES ±.1°	W.S. Darley & Co. ITASCA, IL - CHIPPEWA FALLS, WI
MATERIAL DESCRIPTION: AS LISTED	MATERIAL NO.	PATTERN NO.	DRN WAH CHKD TRCD	DWG - ZSP, INPUT LEFT W/O PRIMER DATE 31OCT2017 SCALE 1/4
THIS DESIGN IS THE PROPERTY OF W.S. DARLEY AND CO. - UNAUTHORIZED REPRODUCTION IS PROHIBITED			DO NOT SCALE PRINT	

MODEL NAME: DZD0064
MIL CREATED: 31OCT2017
SHEET: 1/1

DZD0064