

REVISIONS				
LTR	DESCRIPTION	DATE	CHG NO.	APPRD

YOKE SERIES	A	B
1550	5.77 [146,4]	24.63 [625,6]
1610	5.64 [143,3]	24.86 [631,5]
1710	6.82 [173,2]	25.54 [648,7]
1760	7.20 [182,8]	26.29 [667,8]
1810 (SHOWN)	7.20 [182,8]	26.17 [664,8]

REFERENCE NOTES:
1) WEIGHT = 738 LB.

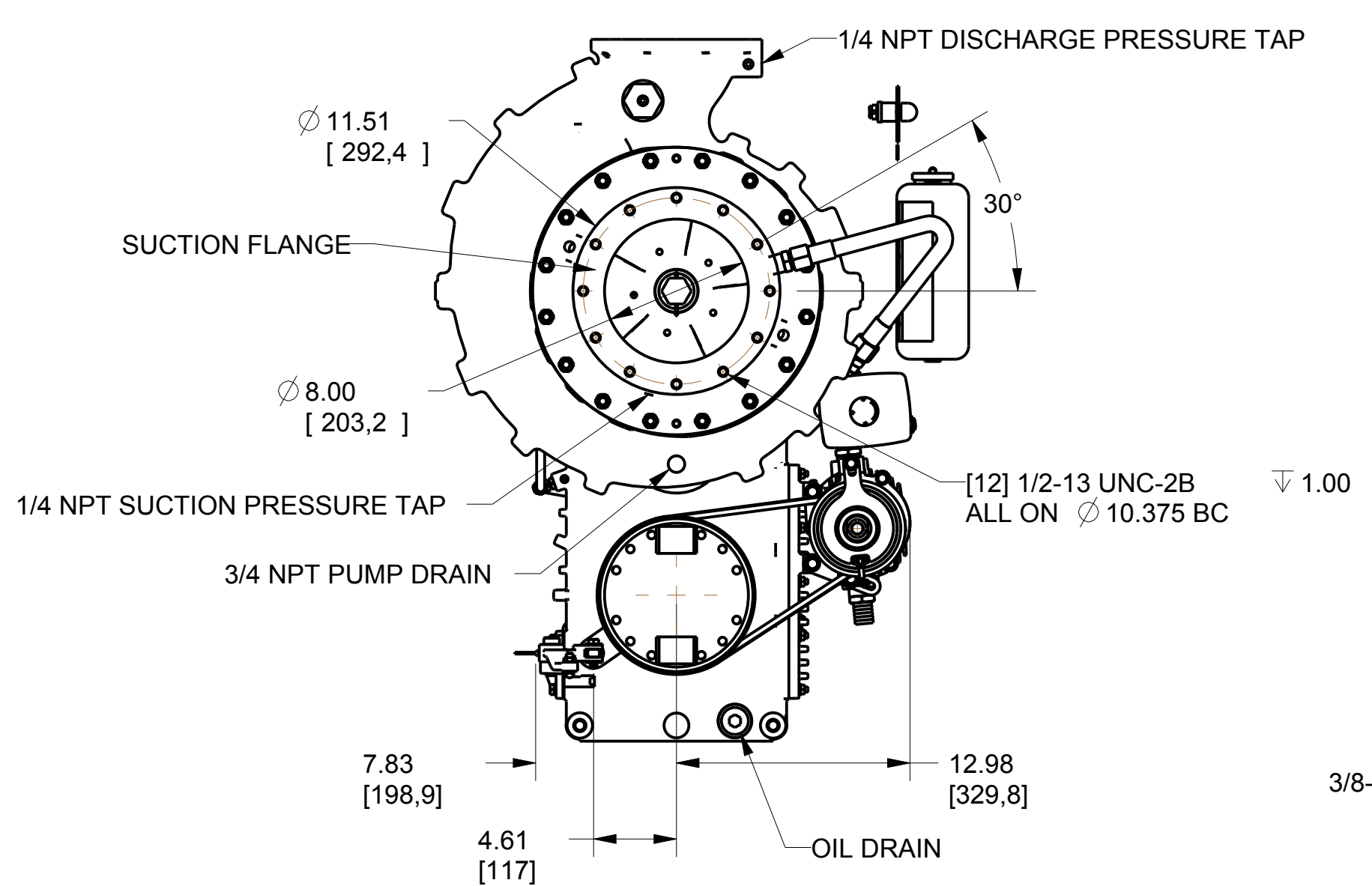
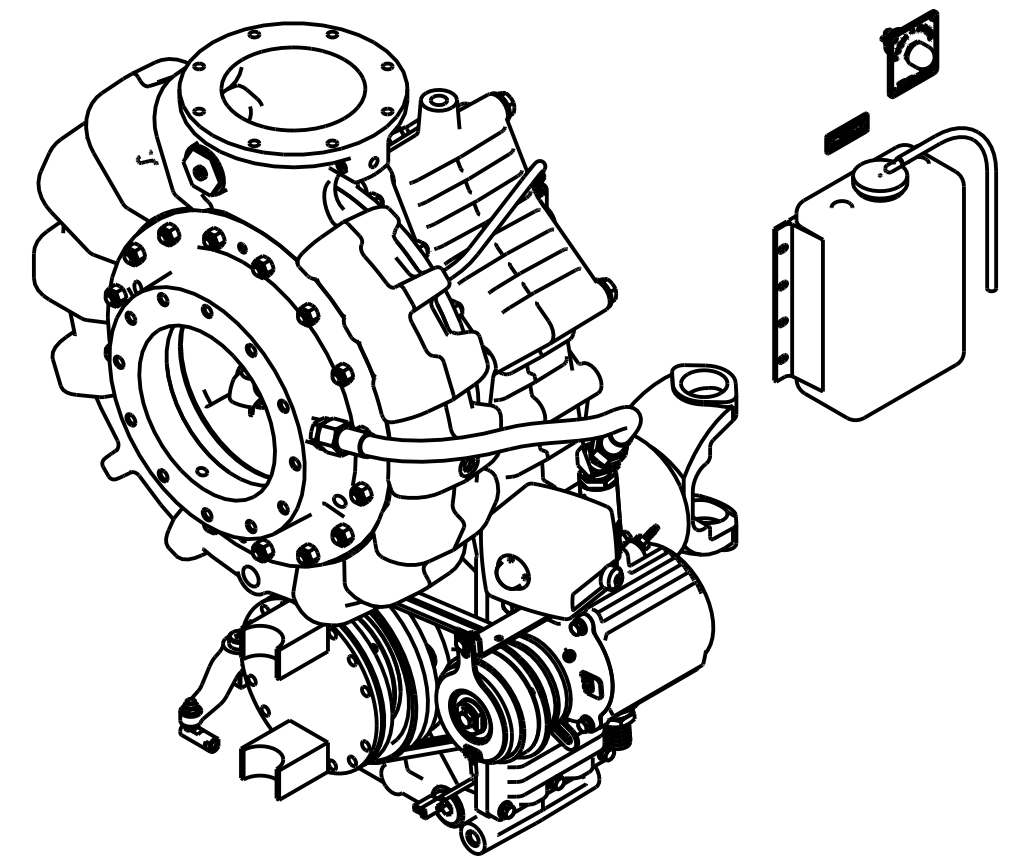
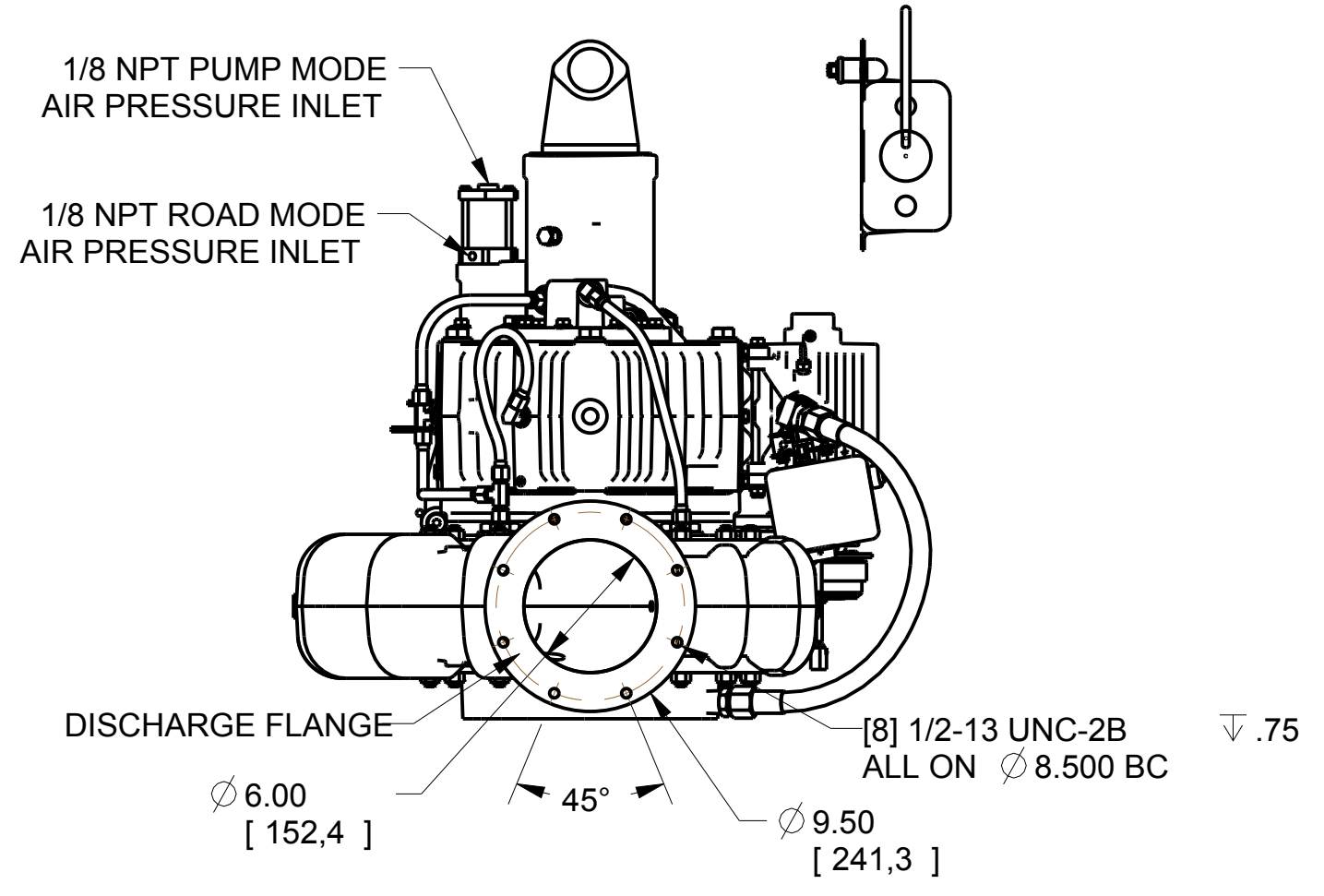

VIEW FROM THE ENGINE TO THE PUMP

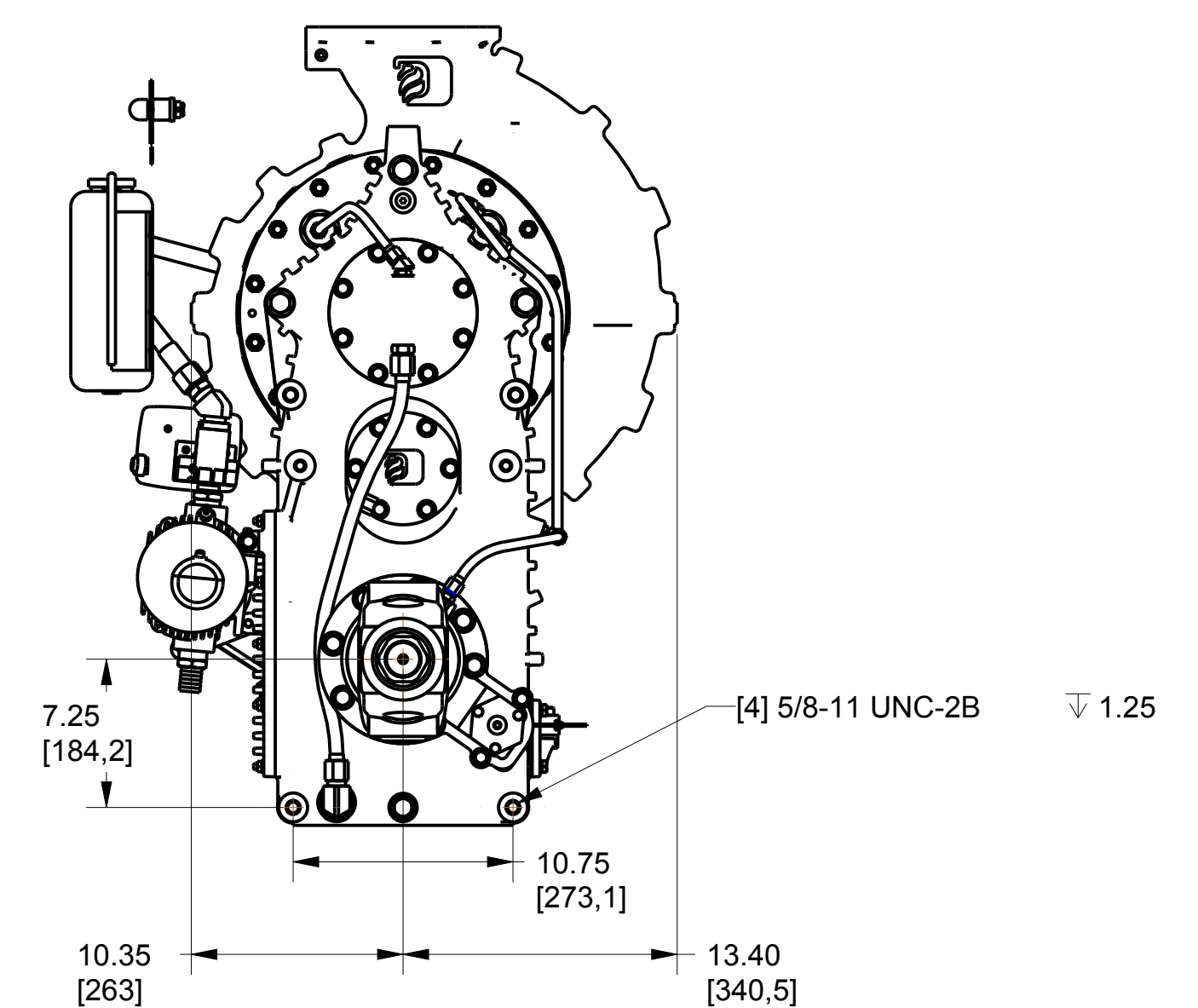
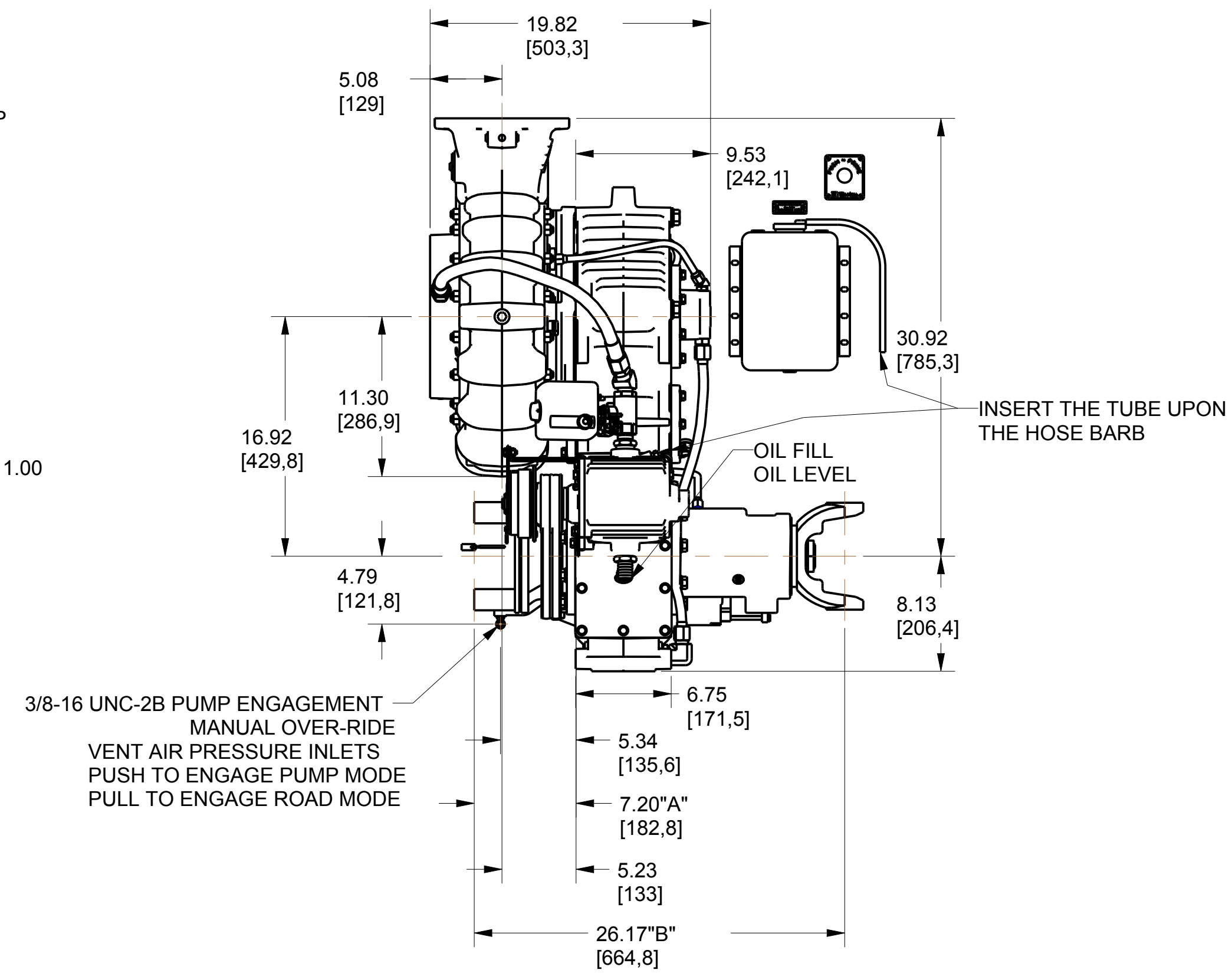

VIEW FROM THE PUMP TO THE ENGINE

REMOVE SHARP EDGES		INCH [MILLIMETER]	OLD PART NO.	TOLERANCE EXCEPT AS NOTED 00 ±.03 2000 ±.010 ANGLES ±1°	W.S. Darley & Co. ITASCA, IL - CHIPPEWA FALLS, WI
MATERIAL DESCRIPTION: THIS DESIGN IS THE PROPERTY OF W.S. DARLEY AND CO. - UNAUTHORIZED REPRODUCTION IS PROHIBITED	ALL DIMENSIONS IN INCHES UNLESS NOTED	DO NOT SCALE PRINT	MATERIAL NO. PATTERN NO.	DRN WAH CHKD TRCD	DWG - ZSM, 3 GEAR, PUMP FORWARD NO FLANGES, W/PRIMER DATE 21NOV2012 SCALE 1/8

MODEL NAME: DZD0017
MIL CREATED: 21NOV2012
SHEET: 1/1

DZD0017