

NOTES:
 1) APPROXIMATE WEIGHT = 1025 LBS [465 KG]
 2) ONLY SHIFT PUMP WHEN DRIVELINE IS NOT SPINNING

REF NOTE: ASSEMBLIES SHOWN
 AH00600 - SHIFT INTERLOCK
 TM00612 - TRANSMISSION
 PL00600 - PUMP ASSEMBLY
 KR07108 - 2.66 GEAR RATIO
 2105703 - SUCTION NIPPLE
 YF06600 - SUCTION NIPPLE FLANGE
 VR00401 - RELIEF VALVE FLANGE
 4822411 - INPUT COMP FLANGE
 4813620 - OUTPUT YOKE
 YF02300 - BLANK FLANGE
 YF01900 - 2.5 NPT FLANGE
 YF06400 - BLANK FLANGE

REVISIONS				
LTR	DESCRIPTION	DATE	CHG NO.	APPR'D

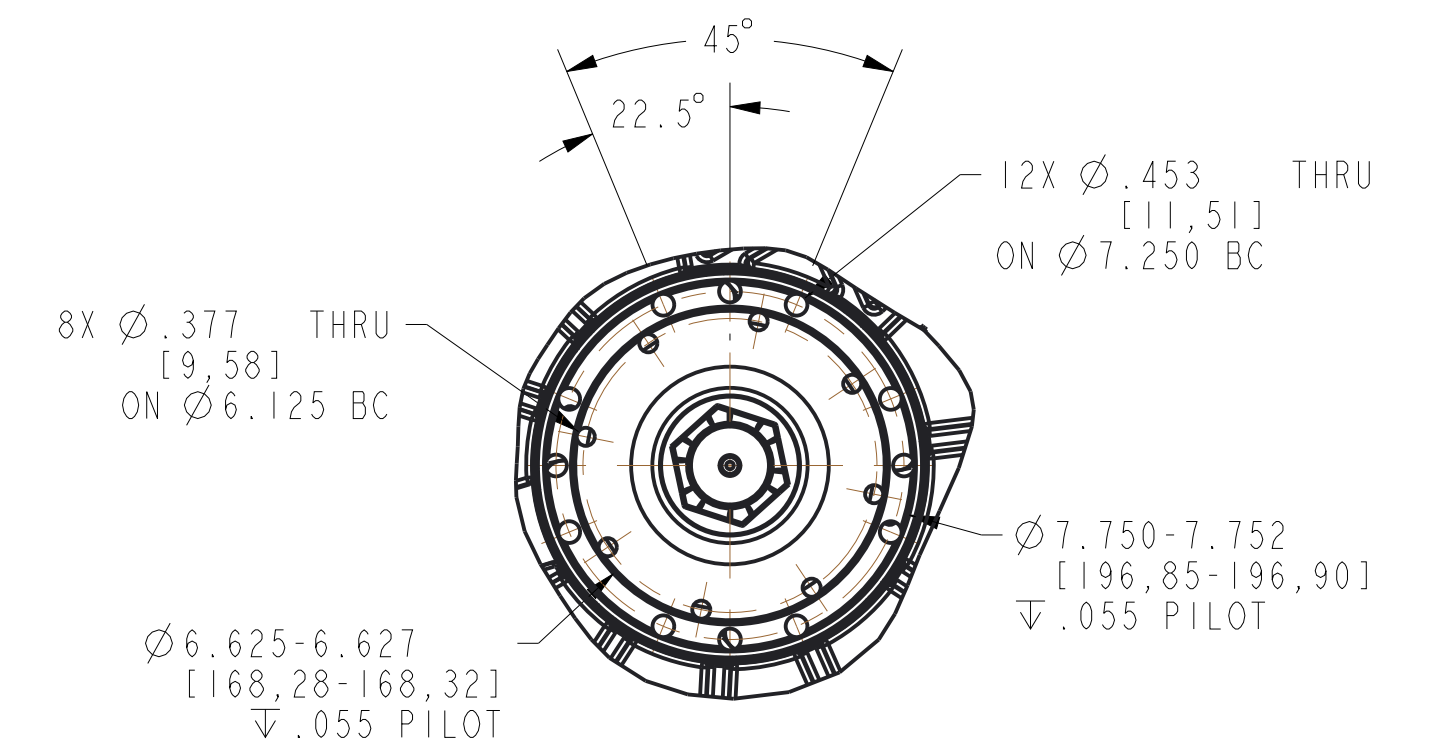
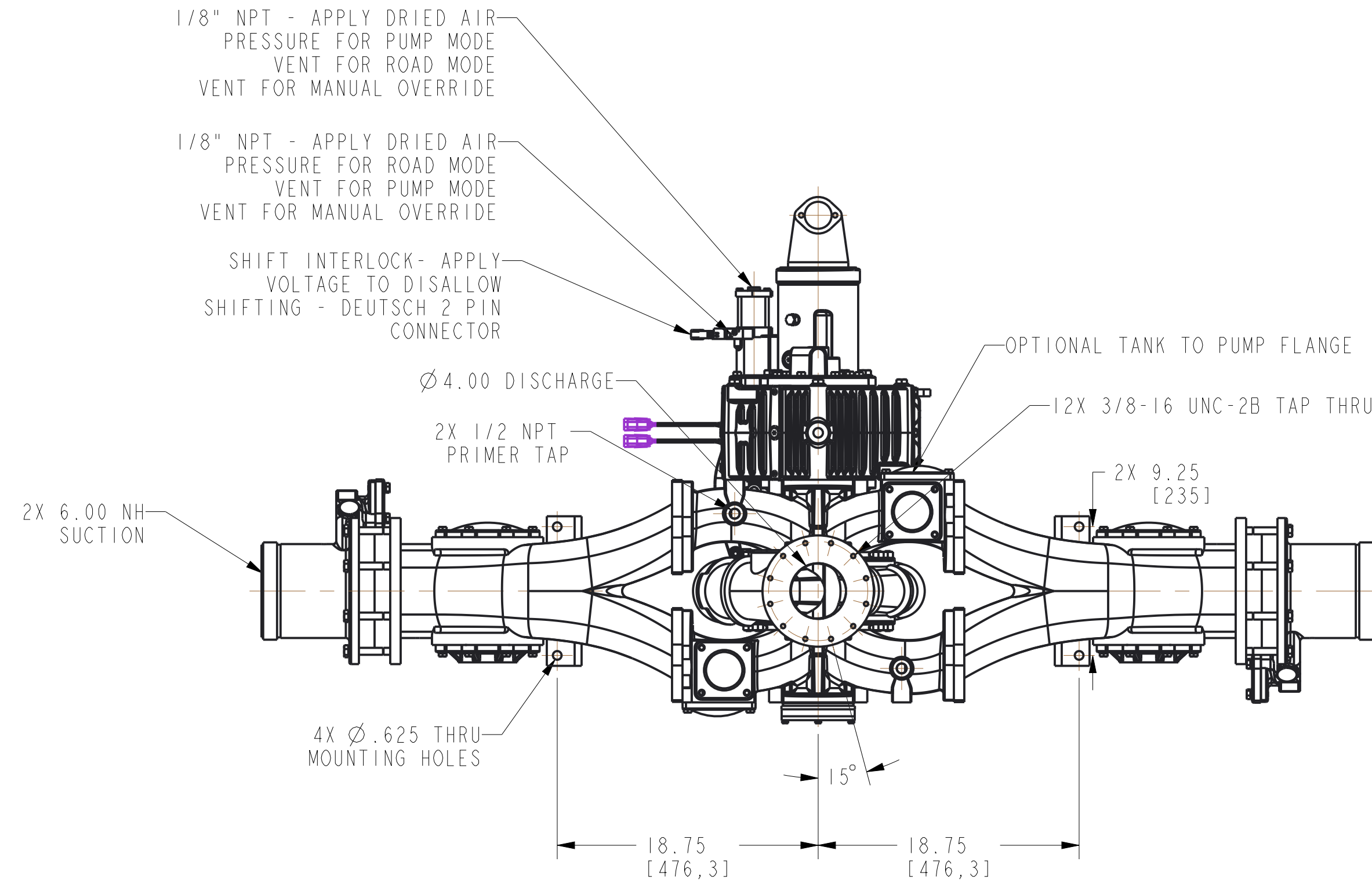
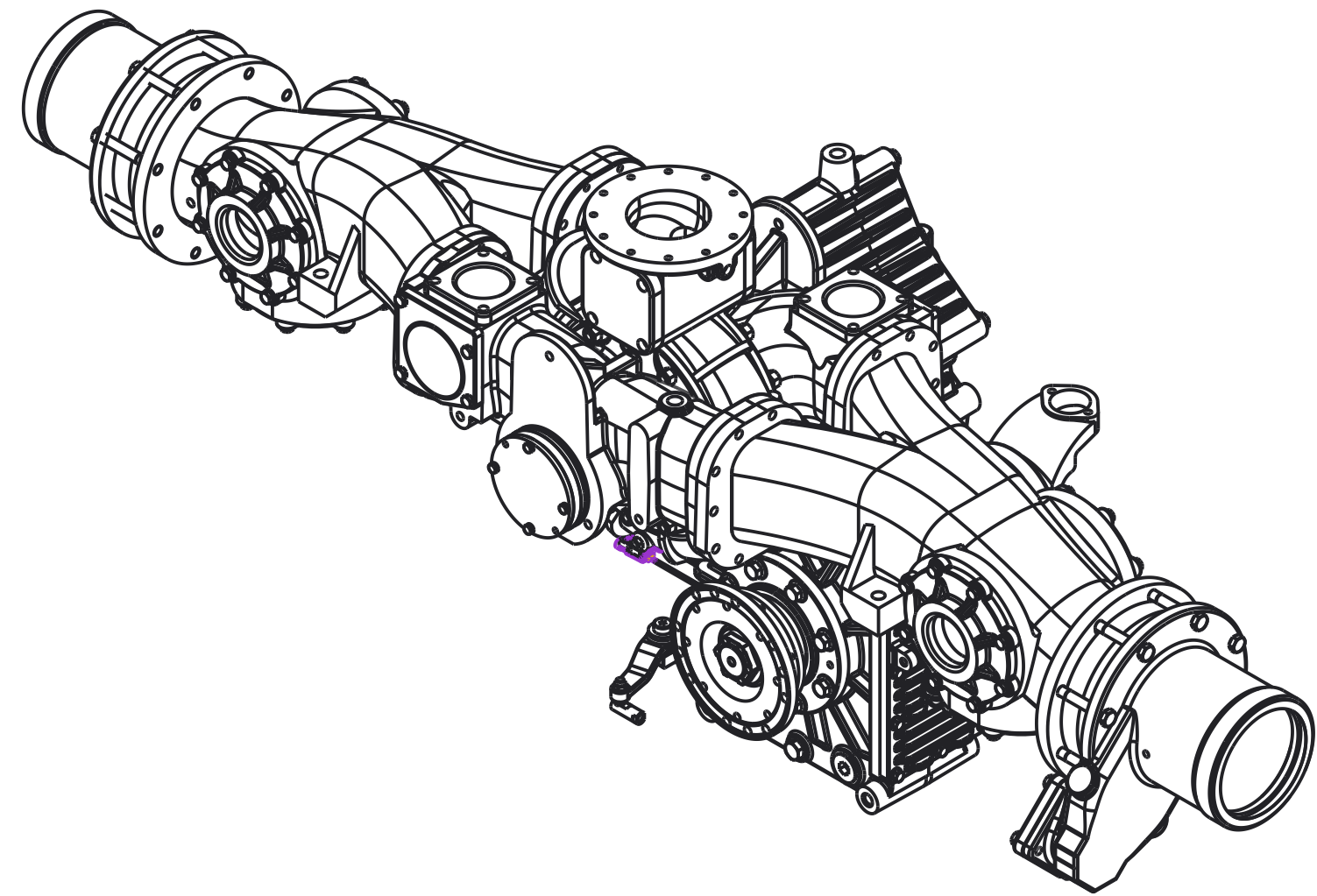

COMPANION FLANGE DETAIL SCALE 1/4

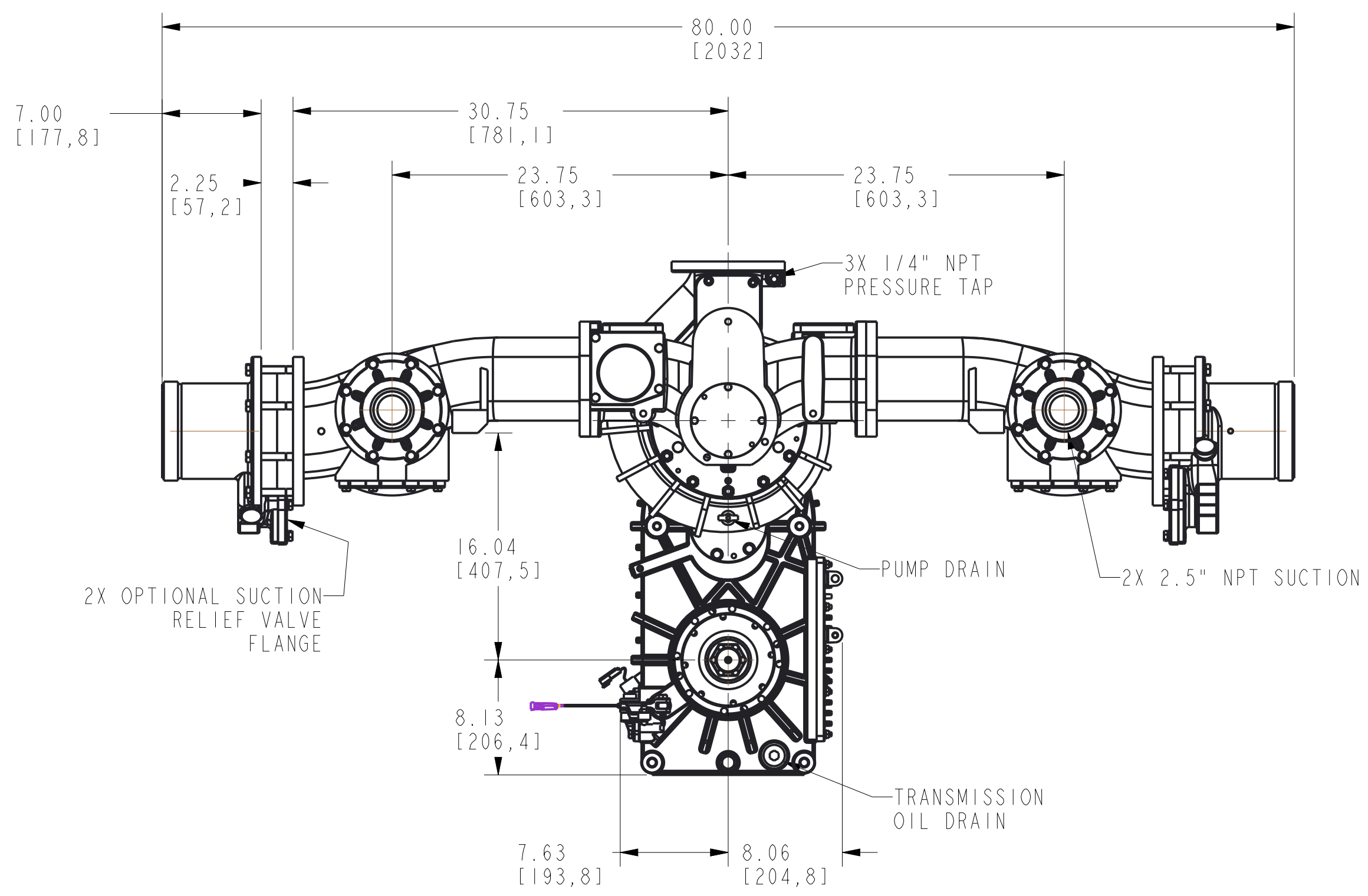
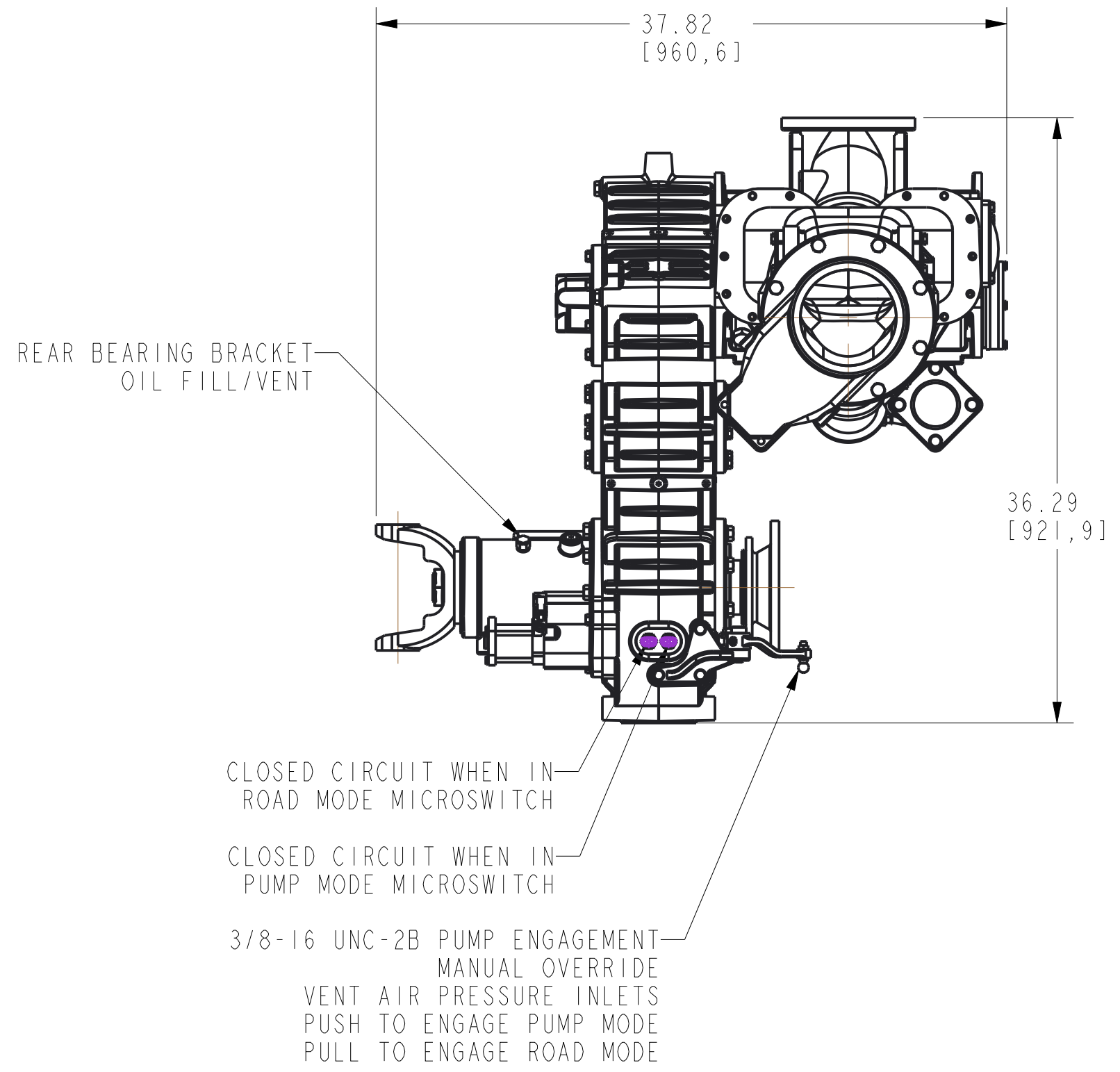

CLOCKWISE ROTATION REQUIRED WHEN VIEW PUMP FROM THE FRONT OF THE TRUCK

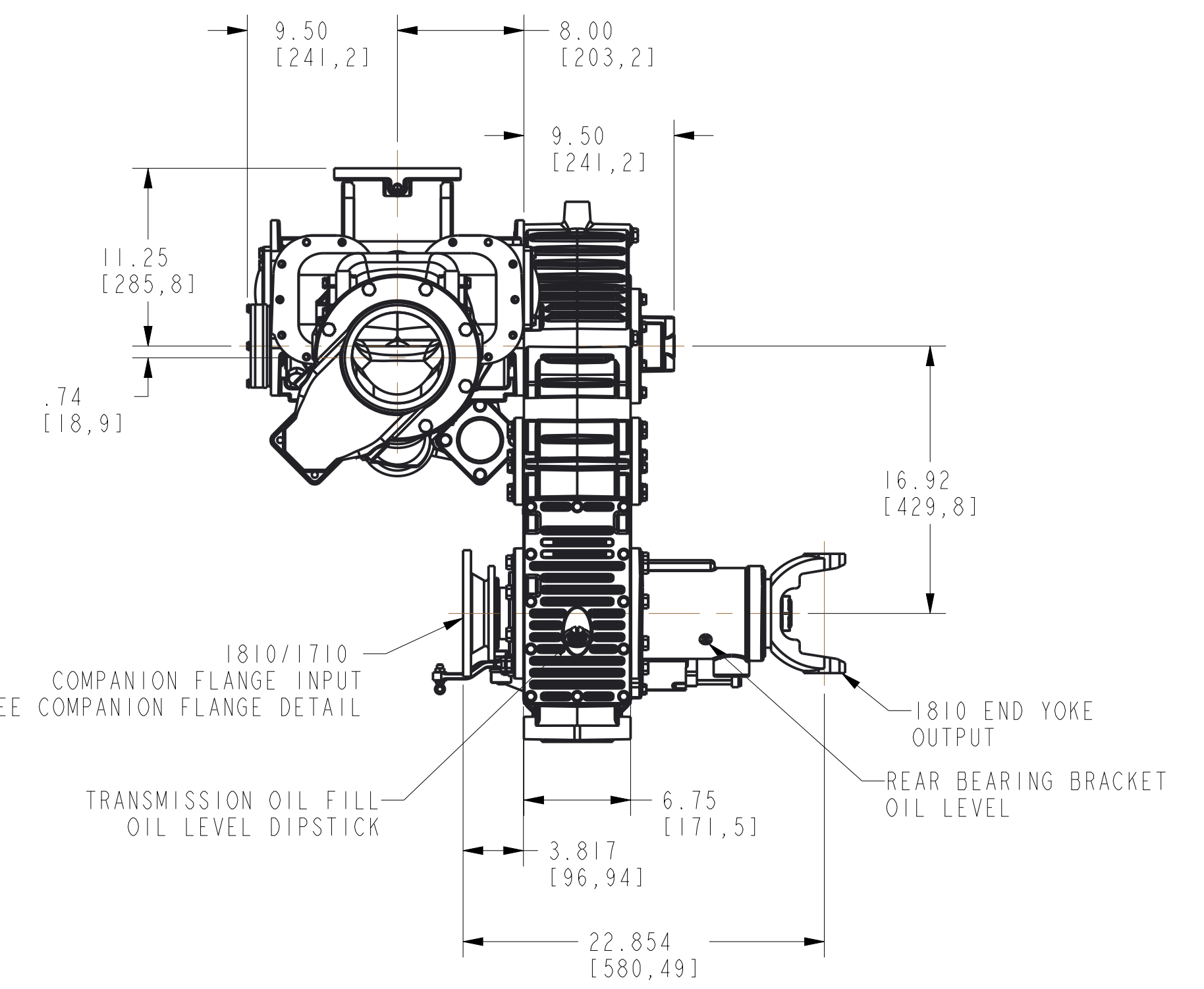

REMOVE SHARP EDGES	INCH [MILLIMETER]	OLD PART NO.	TOLERANCE EXCEPT AS NOTED	W.S. Darley & Co. ITASCA, IL - CHIPPEWA FALLS, WI
MATERIAL DESCRIPTION:		MATERIAL NO.	00 ±.03 .000 ±.010 ANGLES ±.1°	DWG - LDMX-MT, FORWARD DIMENSIONAL
THIS DESIGN IS THE PROPERTY OF W.S. DARLEY AND CO. UNAUTHORIZED REPRODUCTION IS PROHIBITED	ALL DIMENSIONS IN INCHES UNLESS NOTED	DO NOT SCALE PRINT	DR'N SMS CHKD PWS TRCD	DATE 21-Aug-20 SCALE 1/8

DLD2304