

REVISIONS				
LTR	DESCRIPTION	DATE	CHG NO.	APPRD

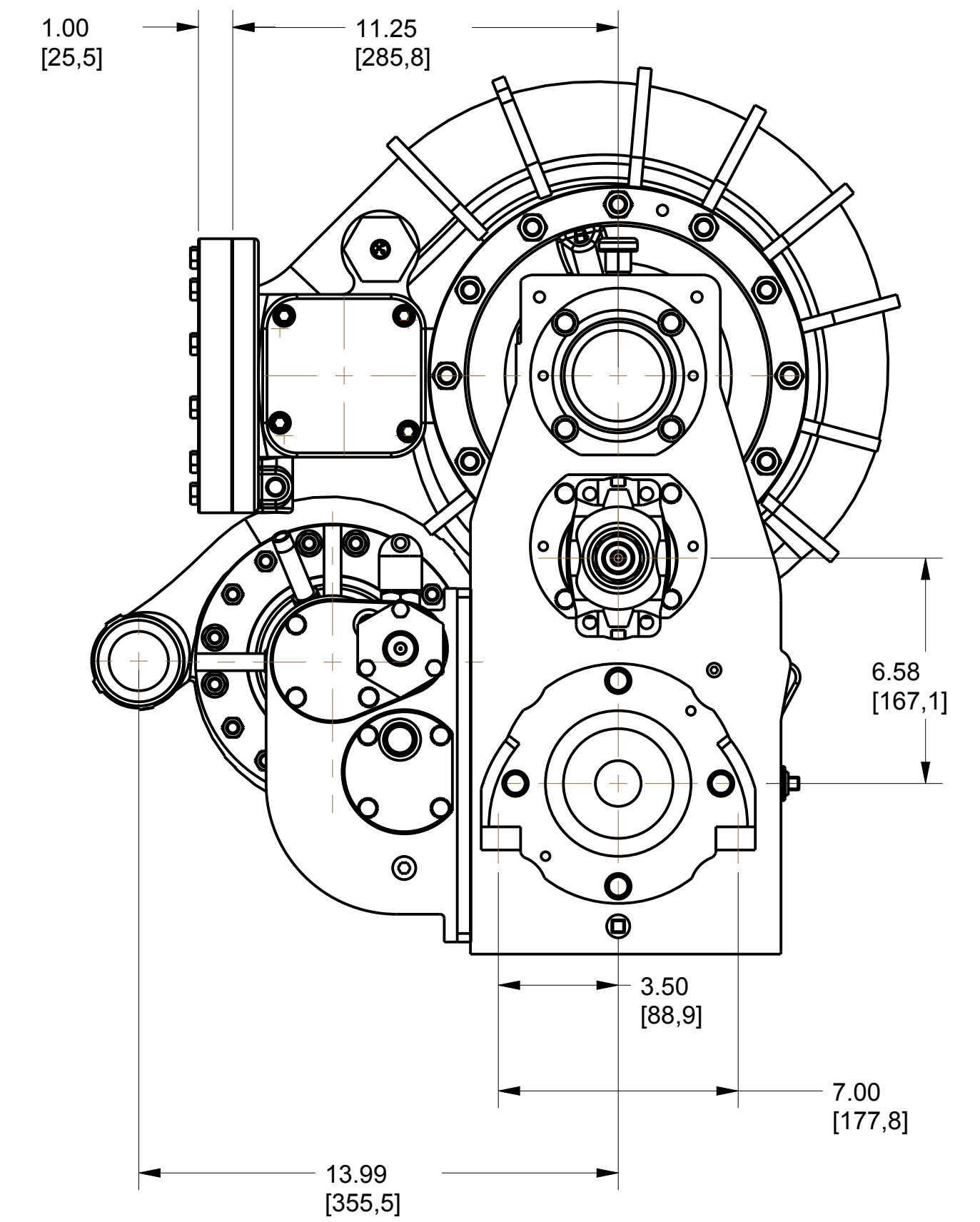
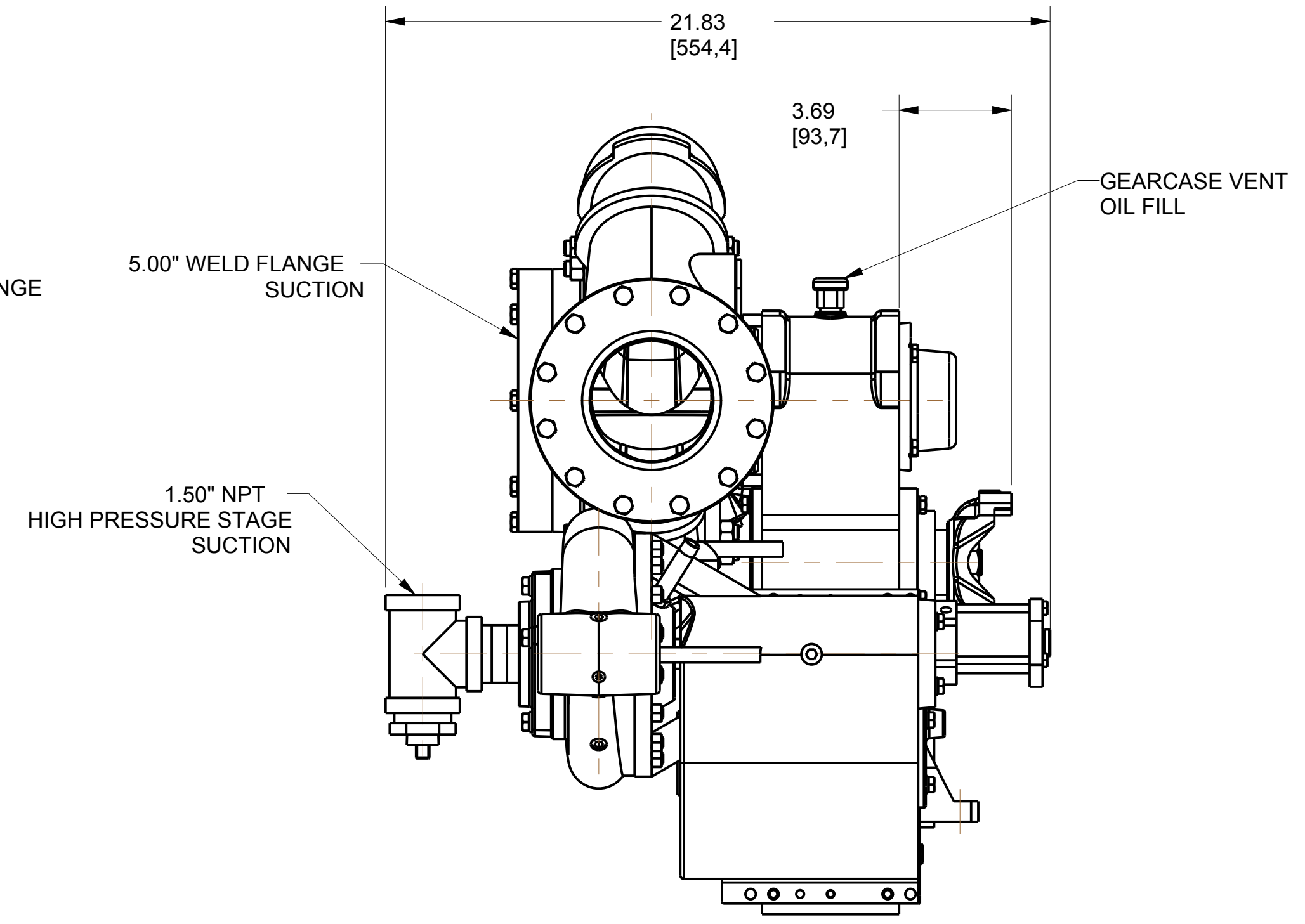
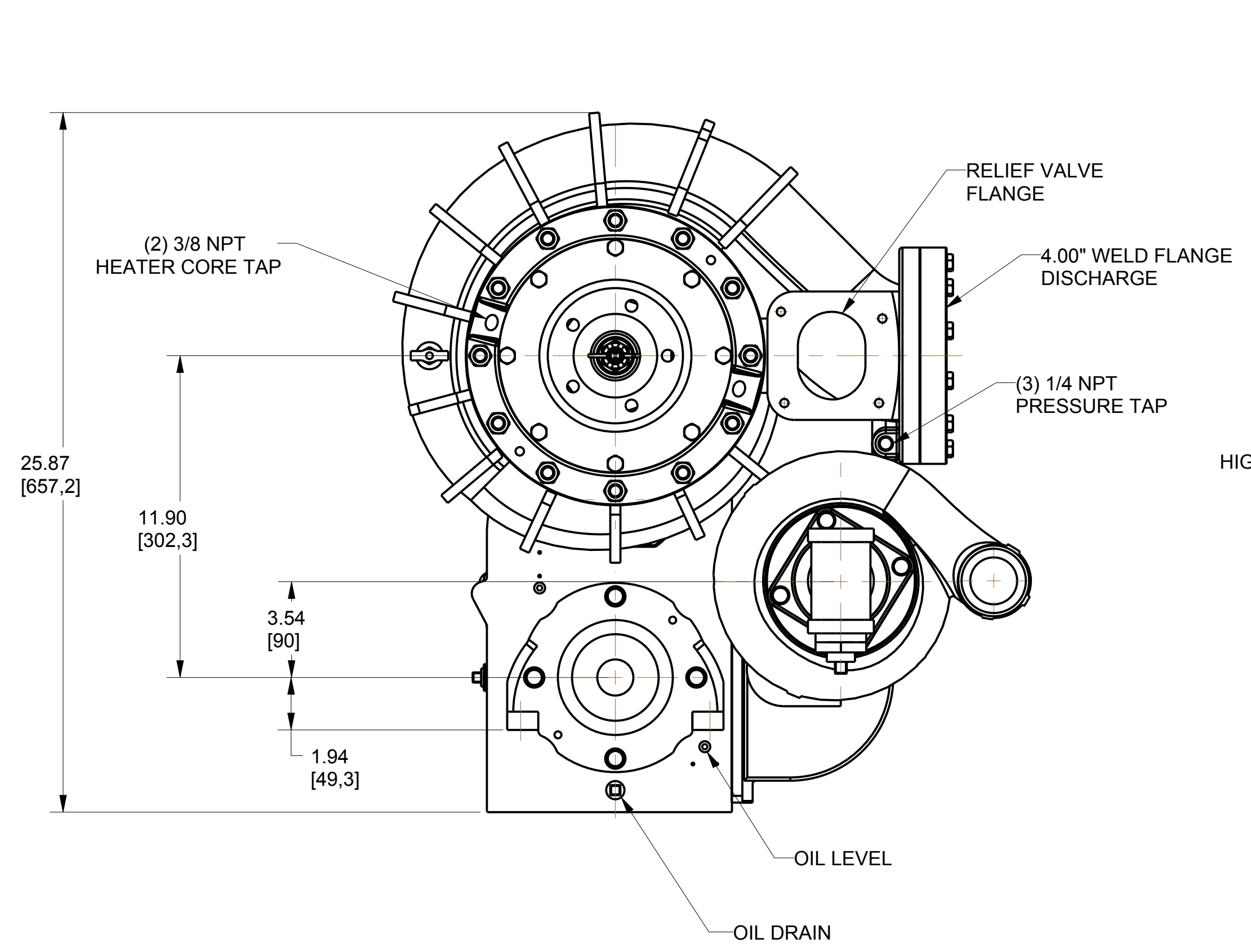
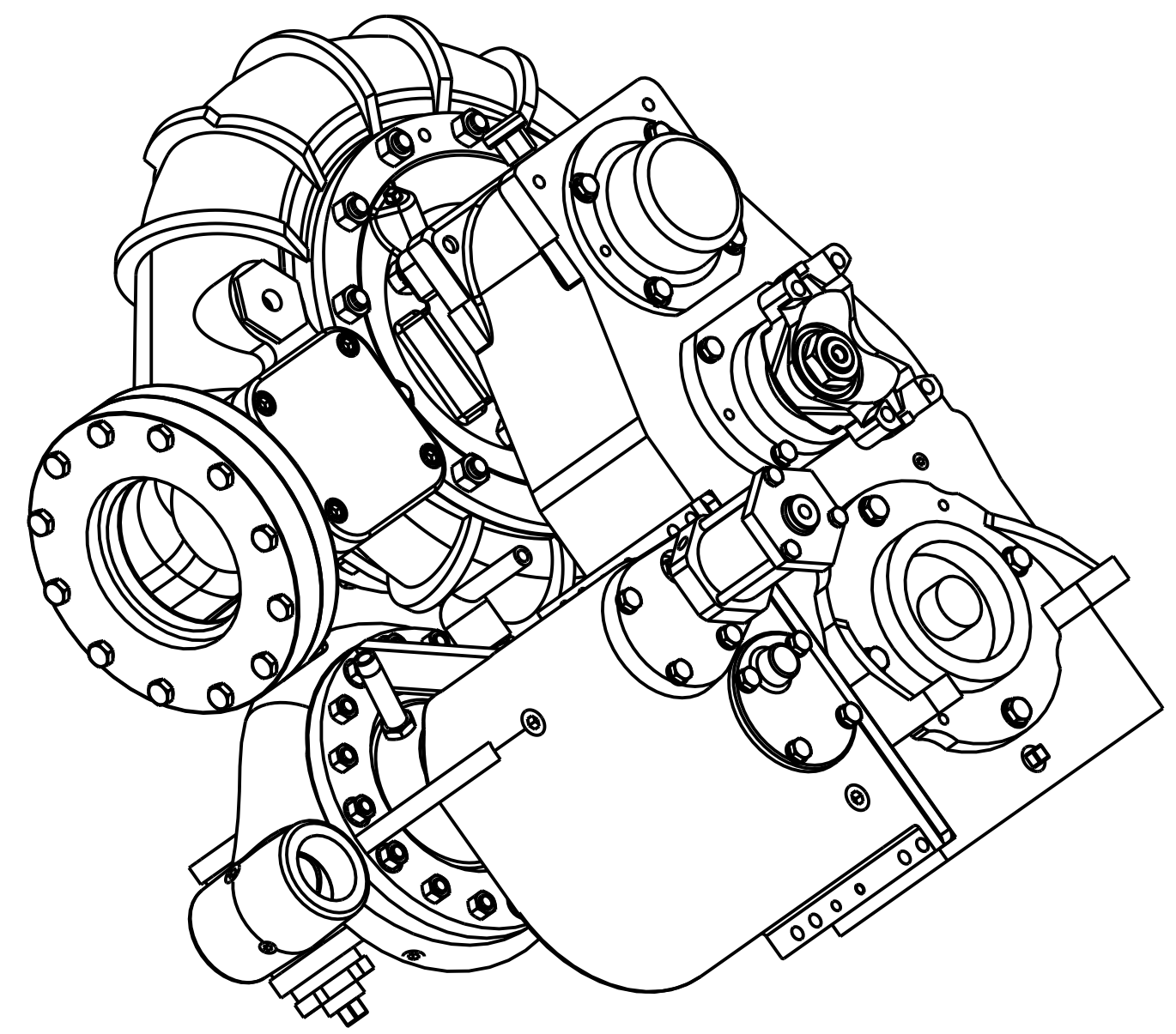
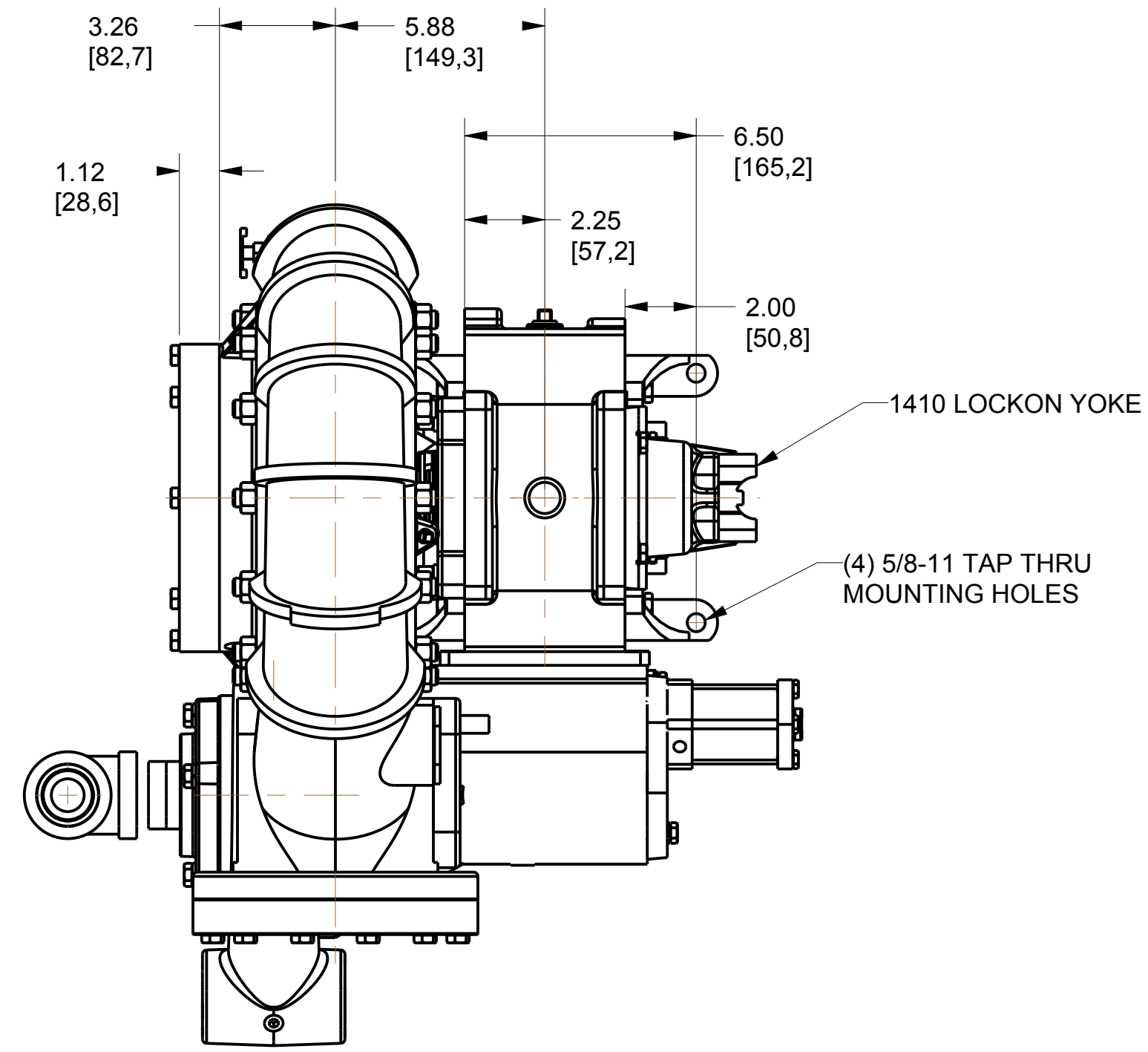
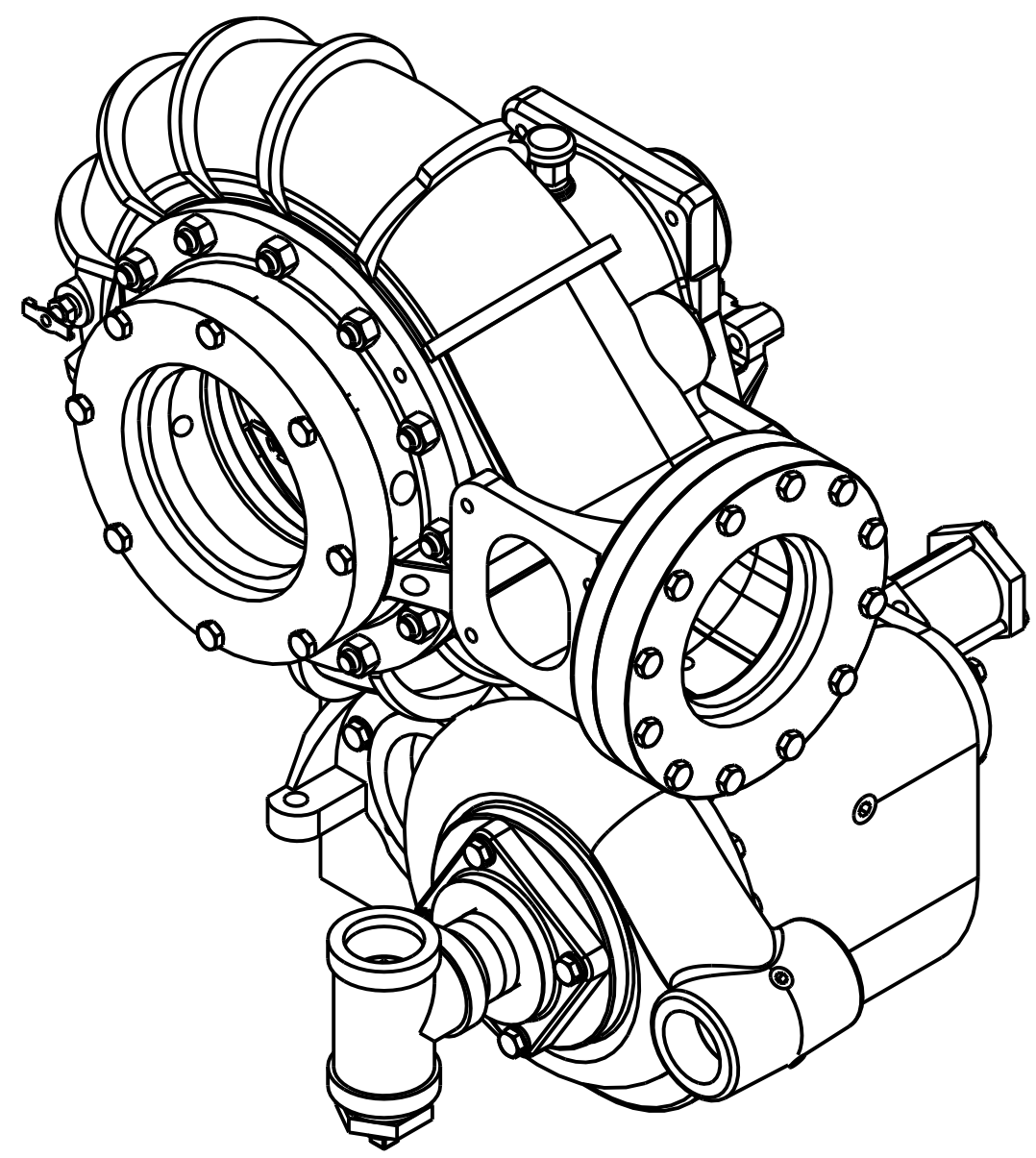

REMOVE SHARP EDGES		INCH [MILLIMETER]				OLD PART NO.	TOLERANCE EXCEPT AS NOTED	
MATERIAL DESCRIPTION:		MATERIAL NO.		PATTERN NO.		DWG - LSRH REAR 3 GEAR LOCK ON		DATE 17-May-11
THIS DESIGN IS THE PROPERTY OF W.S. DARLEY AND CO. - UNAUTHORIZED REPRODUCTION IS PROHIBITED		ALL DIMENSIONS IN INCHES UNLESS NOTED		DO NOT SCALE PRINT		DRYN SMS CHKD MCR TRCD		SCALE 1/4

MODEL NAME: DLD0716      MEL CREATED: 20MAY2011      SHEET: 1/1      D

DLD0716