

REVISIONS			
LTR	DESCRIPTION	DATE	CHG NO. APPR'D

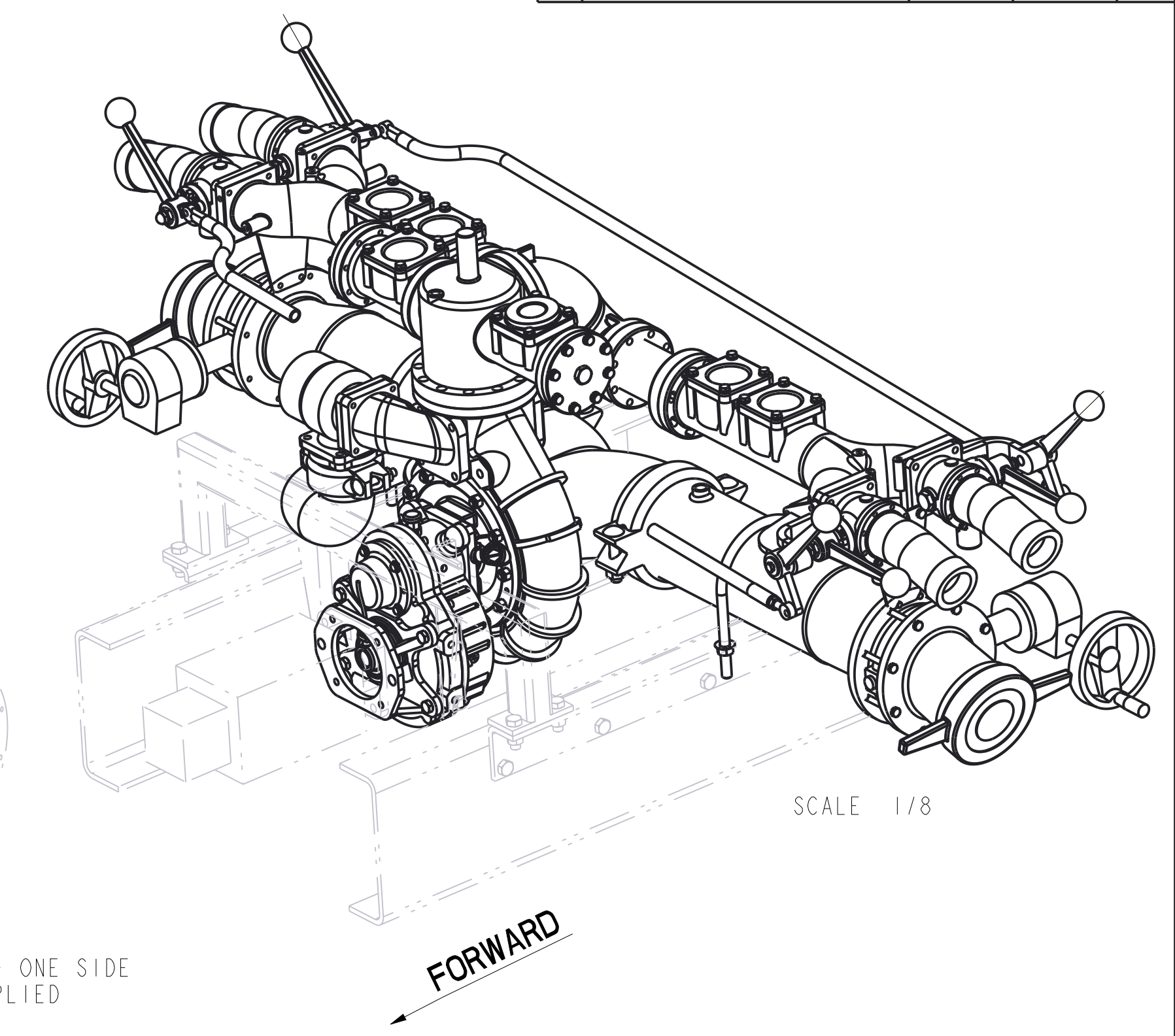

SUGGESTED MOUNT CONFIGURATION
SCALE 1/8

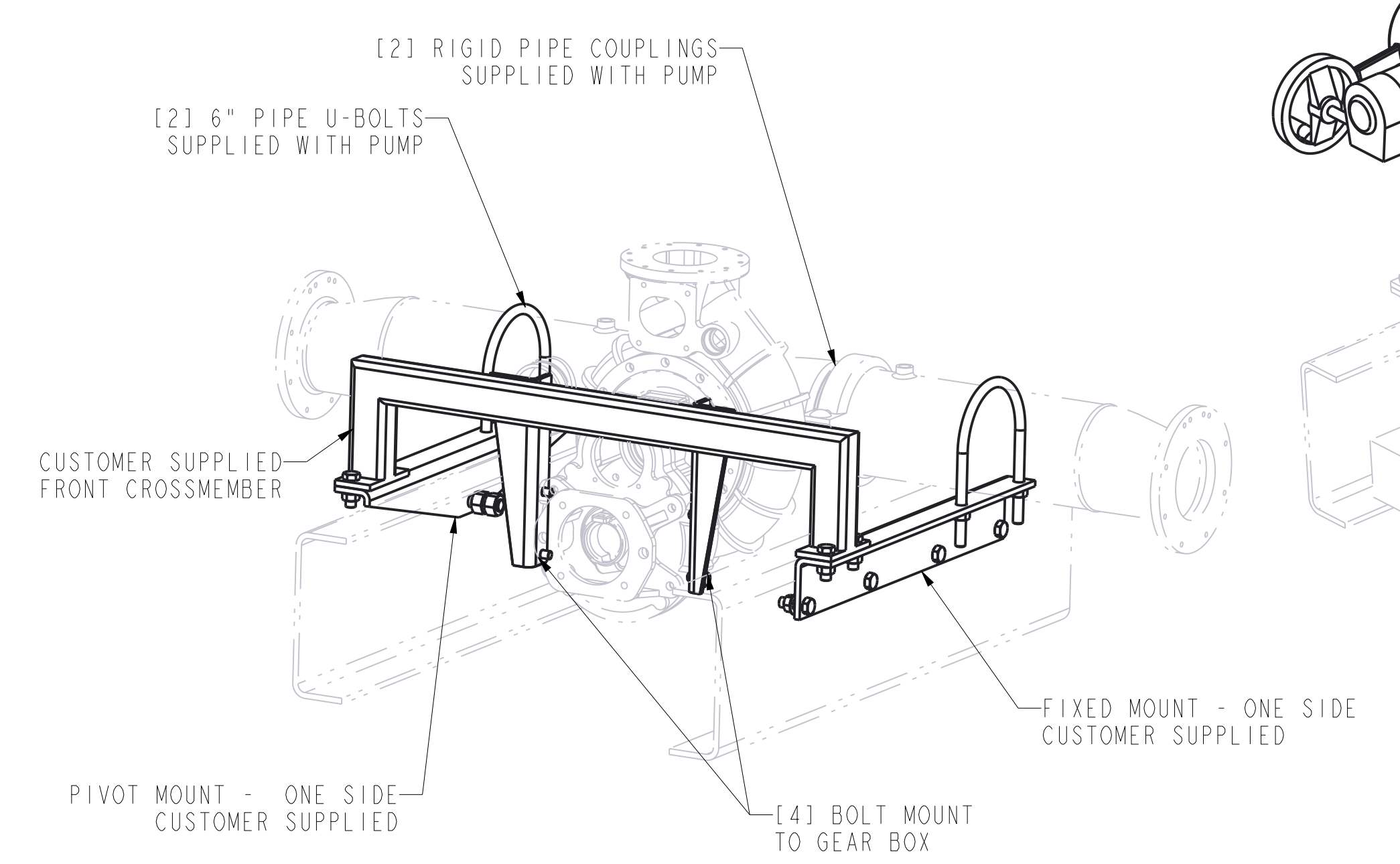
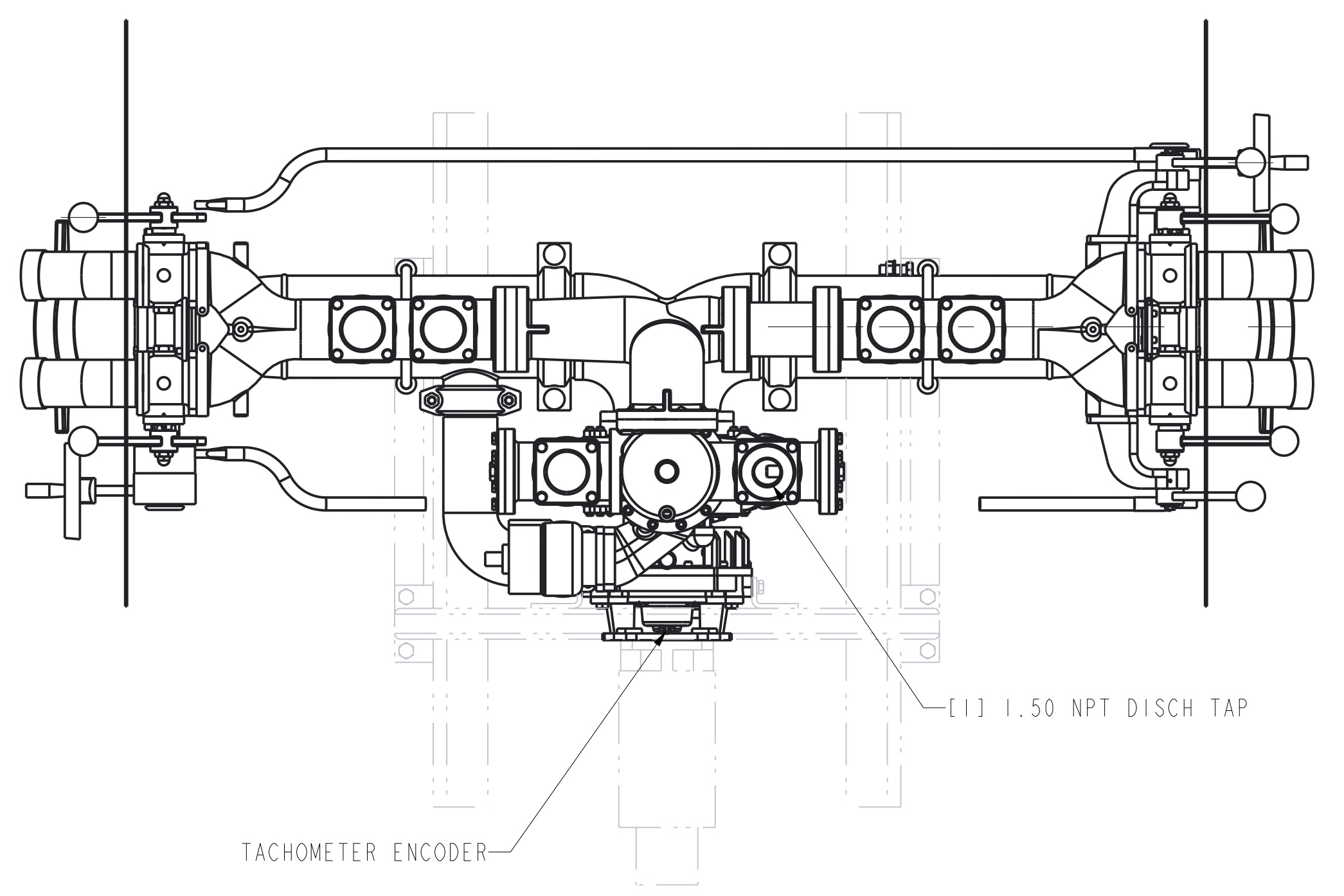
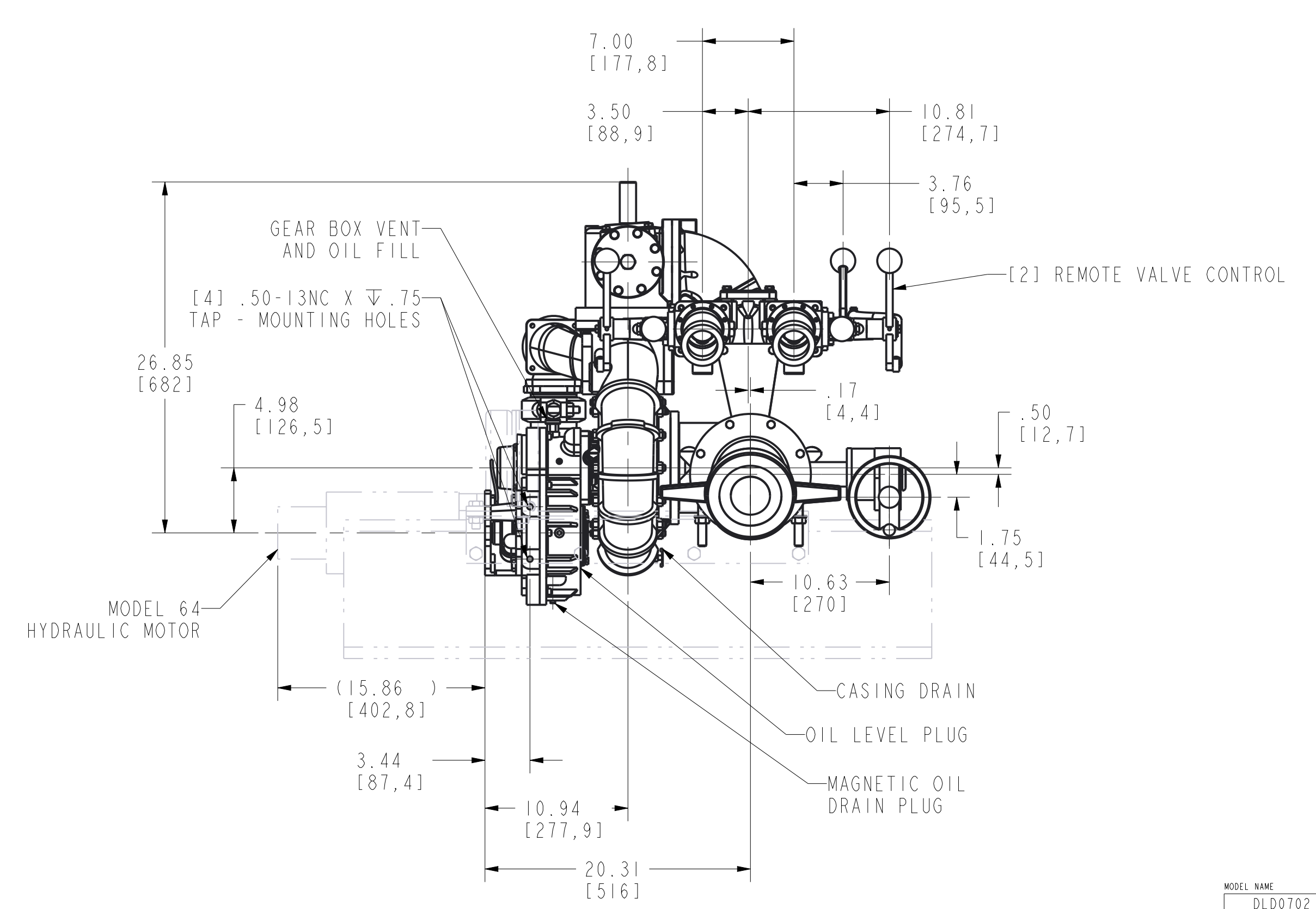
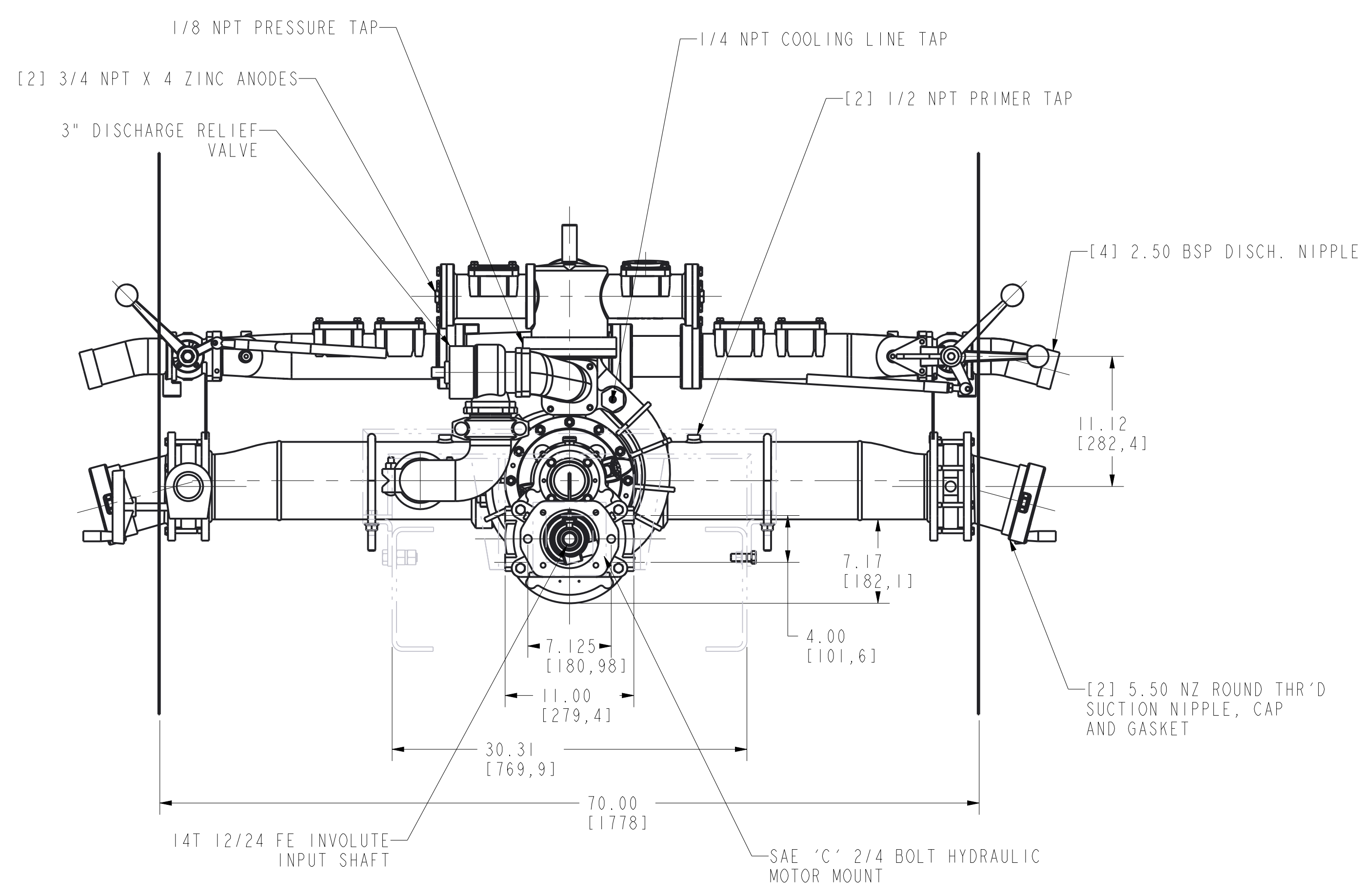

APPROXIMATE NET WEIGHT = 900 LBS (408 Kg)

REMOVE SHARP EDGES		INCH (MILLIMETER)		TOLERANCE EXCEPT AS NOTED		W.S. Darley & Co.	
MATERIAL DESCRIPTION:		MATERIAL NO.		PATTERN NO.		DWG - LSH PUMP REAR, VERT GRCS DIMENSIONAL, PROJE MODEL	
THIS DESIGN IS THE PROPERTY OF W.S. DARLEY AND CO. UNAUTHORIZED REPRODUCTION IS PROHIBITED.		ALL DIMENSIONS IN INCHES UNLESS NOTED		DO NOT SCALE PRINT		DATE 12-Sep-00	
						SCALE 1/8	
						DLD0702	