

REVISIONS				
LT/R	DESCRIPTION	DATE	CHG NO.	APPR'D
-	-	-	-	-

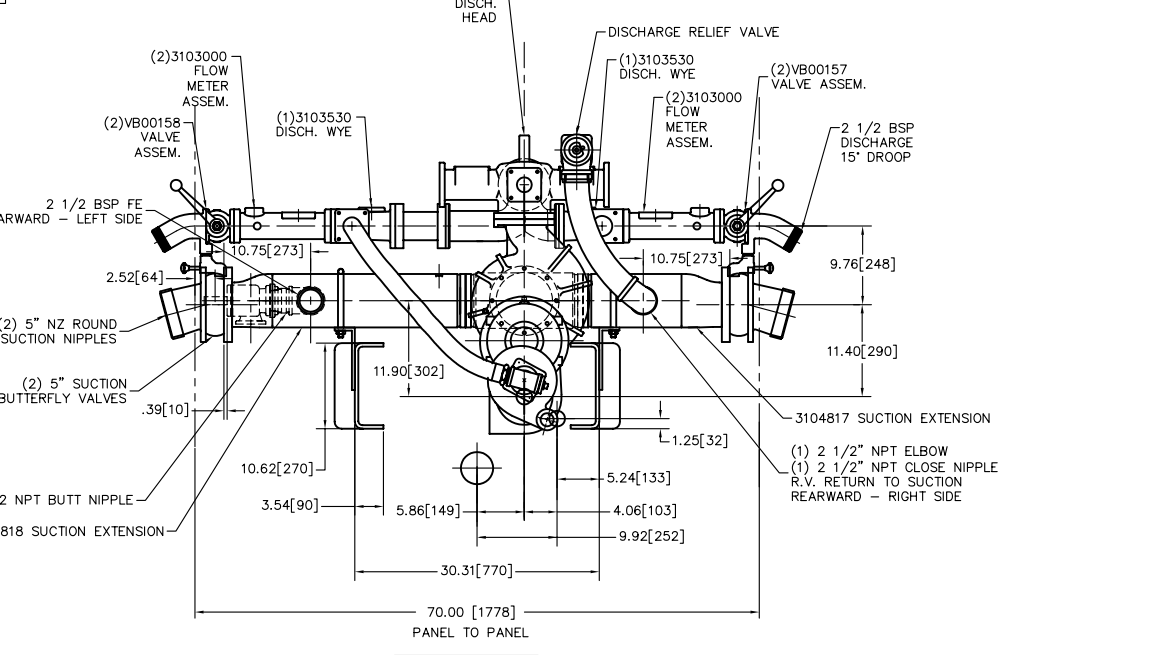
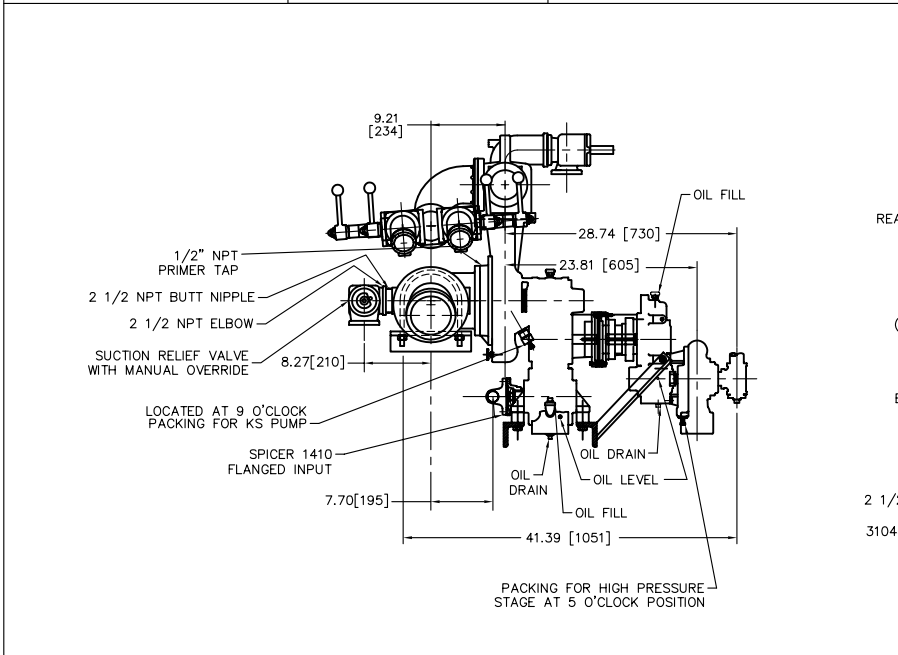
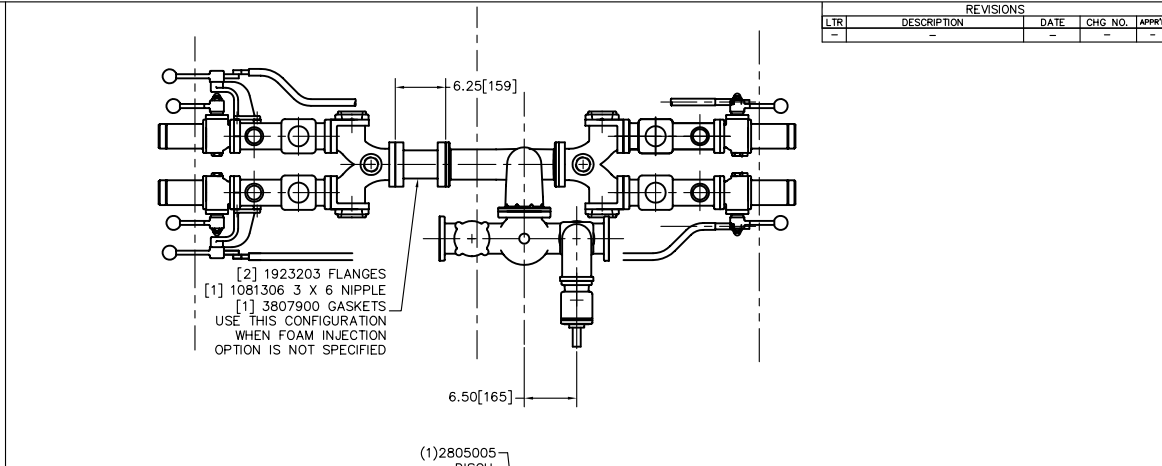
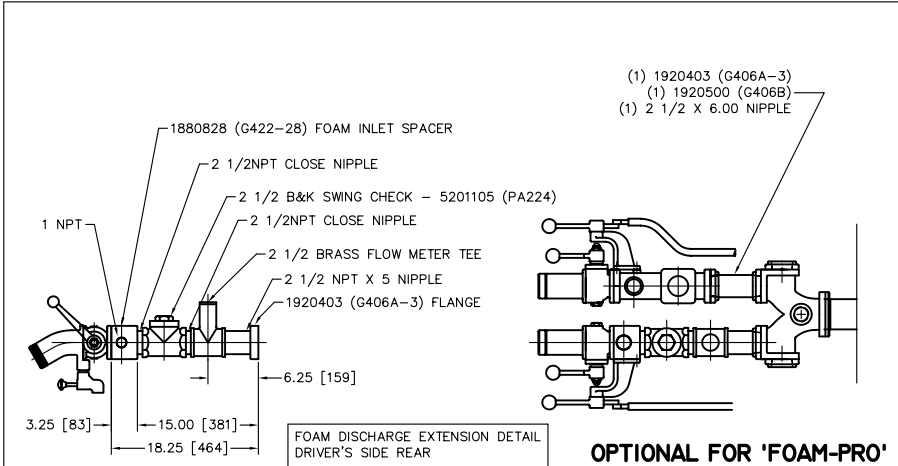

REAR VIEW

1060 LB
480 KG

REVISED PER FAXED REQUEST
ON OCTOBER 28, 1997

INCH [MILLIMETER]

THIRD ANGLE PROJECTION

TOLERANCE EXCEPT AS NOTED .005 ± .000 ANGLES 15°

W.S. DARLEY & CO.
MANUFACTURERS - DUNEDIN, NEW ZEALAND

DWG - KSPA41, NEW ZEALAND

DATE OCT20,97

SCALE 1/8

DKD0711

THIS DESIGN IS THE PROPERTY OF W.S. DARLEY AND CO. - UNAUTHORIZED REPRODUCTION IS PROHIBITED

ALL DIMENSIONS IN INCHES UNLESS NOTED

DO NOT SCALE PRINT

DATE OCT20,97

SCALE 1/8