

REVISIONS				
LTR	DESCRIPTION	DATE	CHG NO.	APPR'D
A	HEF10.5BS WAS HEF13BS	10MAY2015	ED 10943	TED

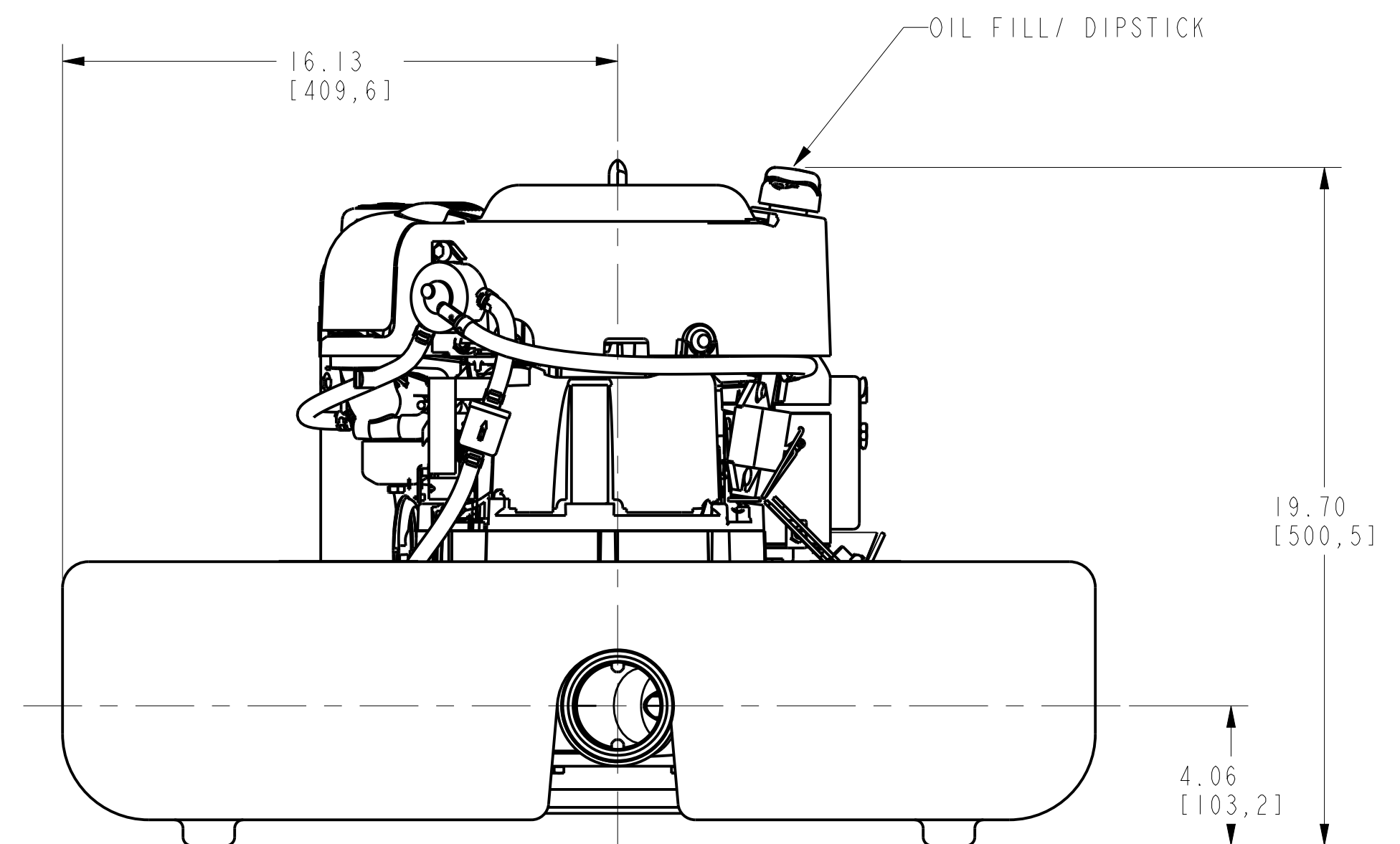
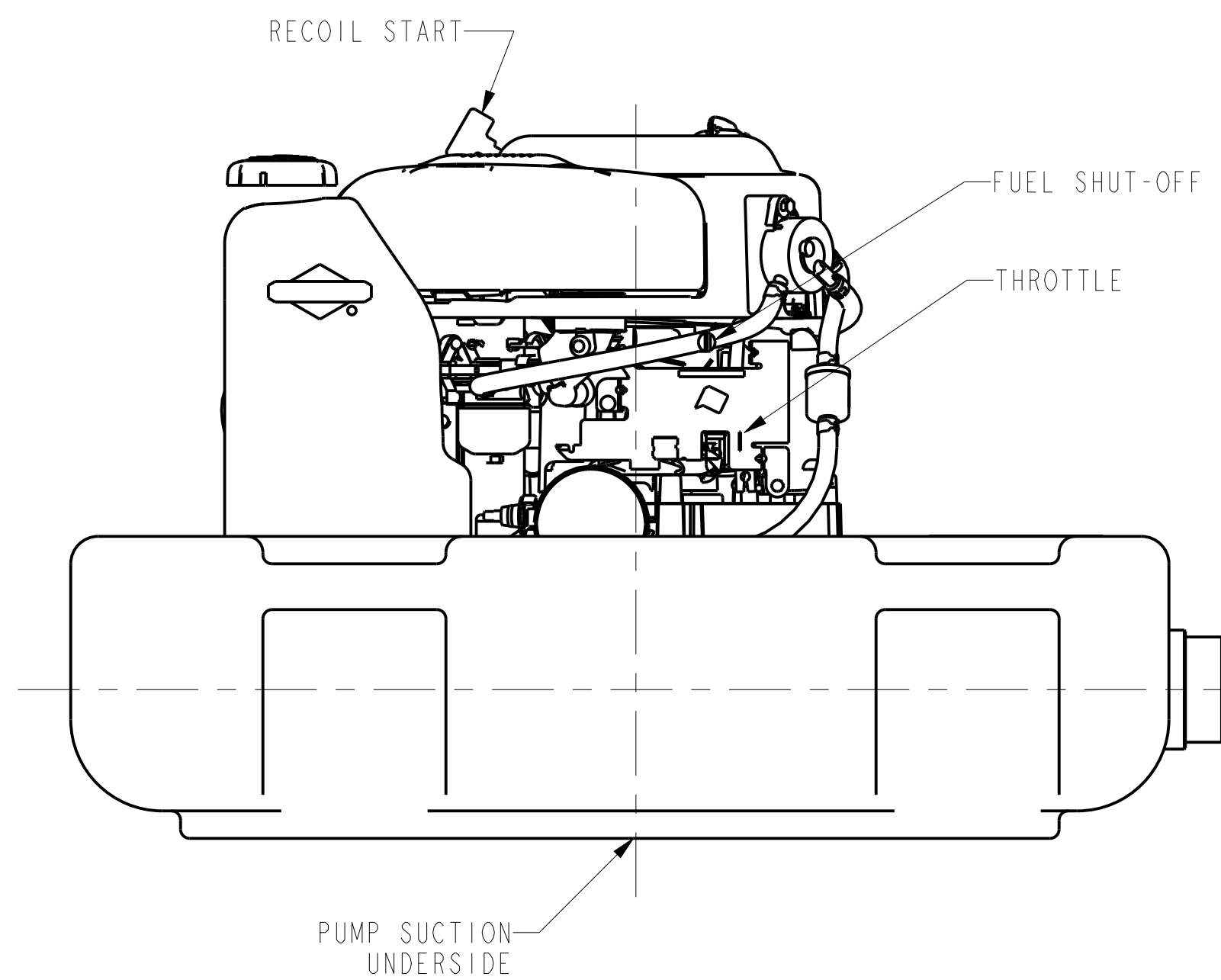
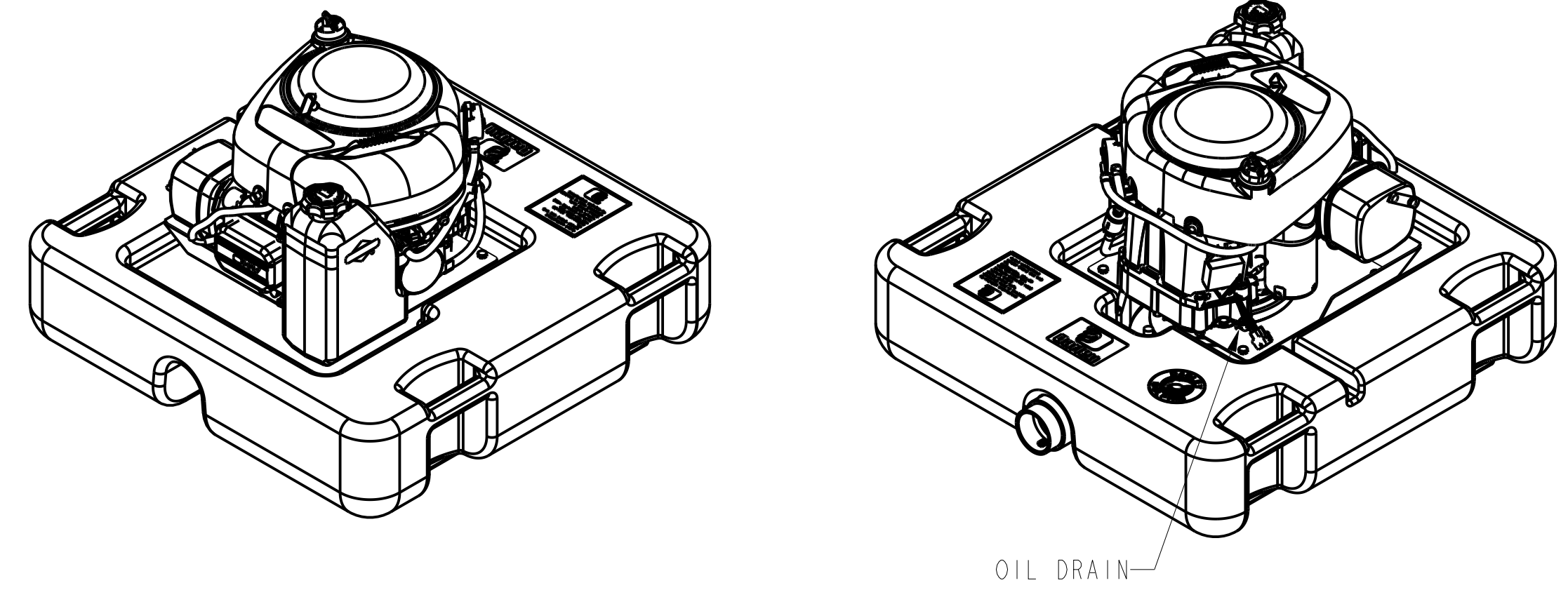
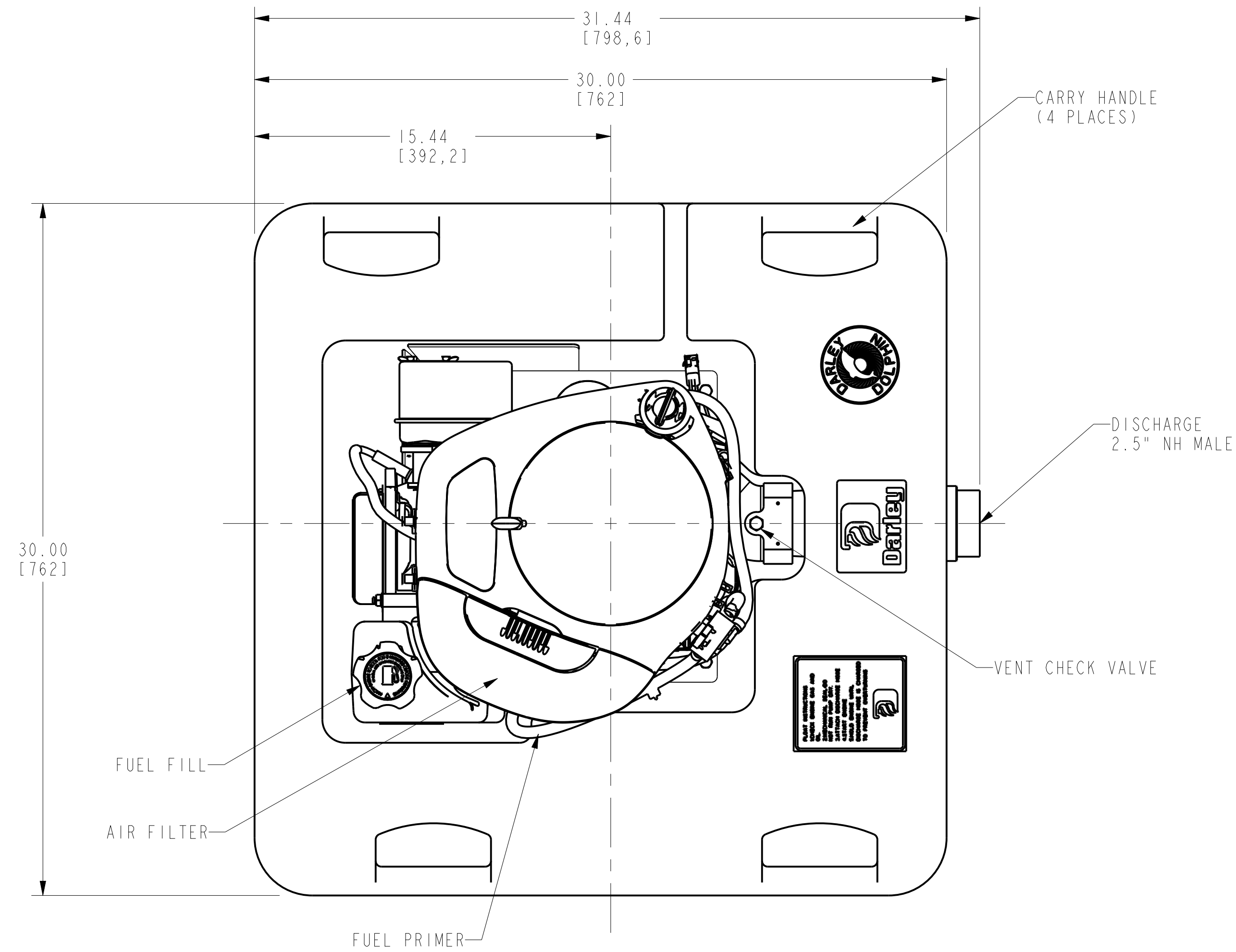

APPROXIMATE WEIGHT
120 LBS
(95.3 KG)

REMOVE SHARP EDGES

INCH (MILLIMETER)



OLD PART NO.

TOLERANCE EXCEPT AS NOTED

W.S. Darley & Co.
ITASCA, IL - CHIPPEWA FALLS, WI

MATERIAL DESCRIPTION:

MATERIAL NO.

PATTERN NO.

DR'N AAN

PUMP - HEF10.5BS, FLOAT PUMP

THIS DESIGN IS THE PROPERTY OF W.S. DARLEY AND CO. - UNAUTHORIZED REPRODUCTION IS PROHIBITED

ALL DIMENSIONS IN INCHES UNLESS NOTED

DO NOT SCALE PRINT

CHWD TED
TRCD

DATE 25-Feb-08
SCALE 1/8
DHD1701

MODEL NAME: PH00304
MOL CREATED: 2/25/08
SHEET: 1/1
D

A