

REVISIONS				
LTR	DESCRIPTION	DATE	CHG NO.	APPRD

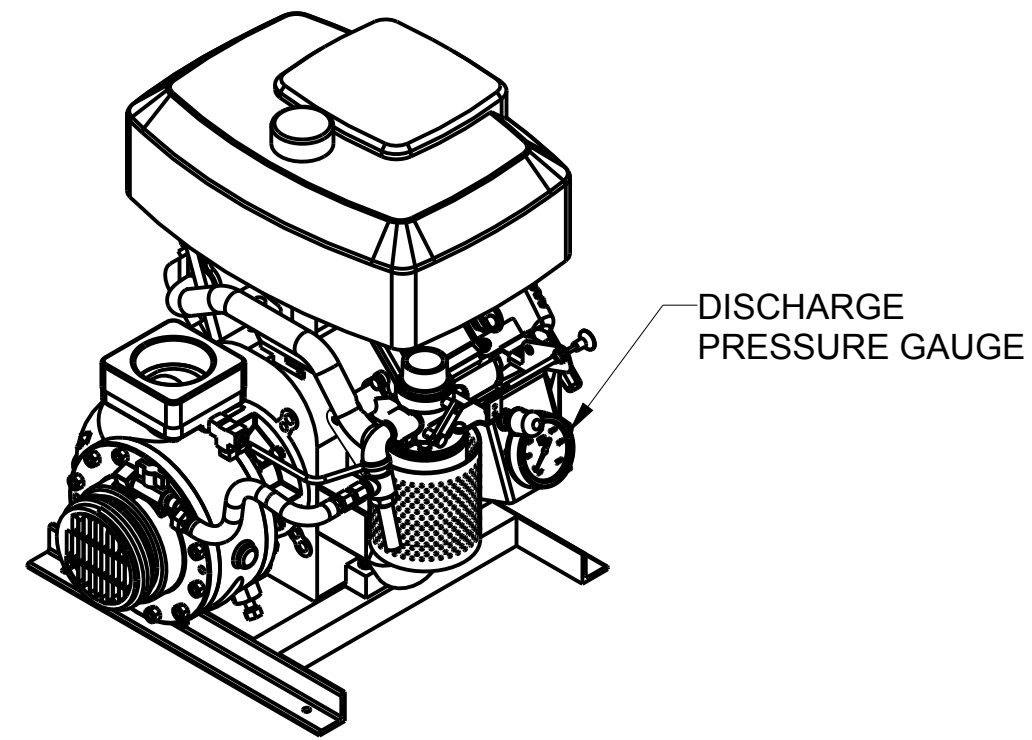

DISCHARGE PRESSURE GAUGE

SCALE 1/8

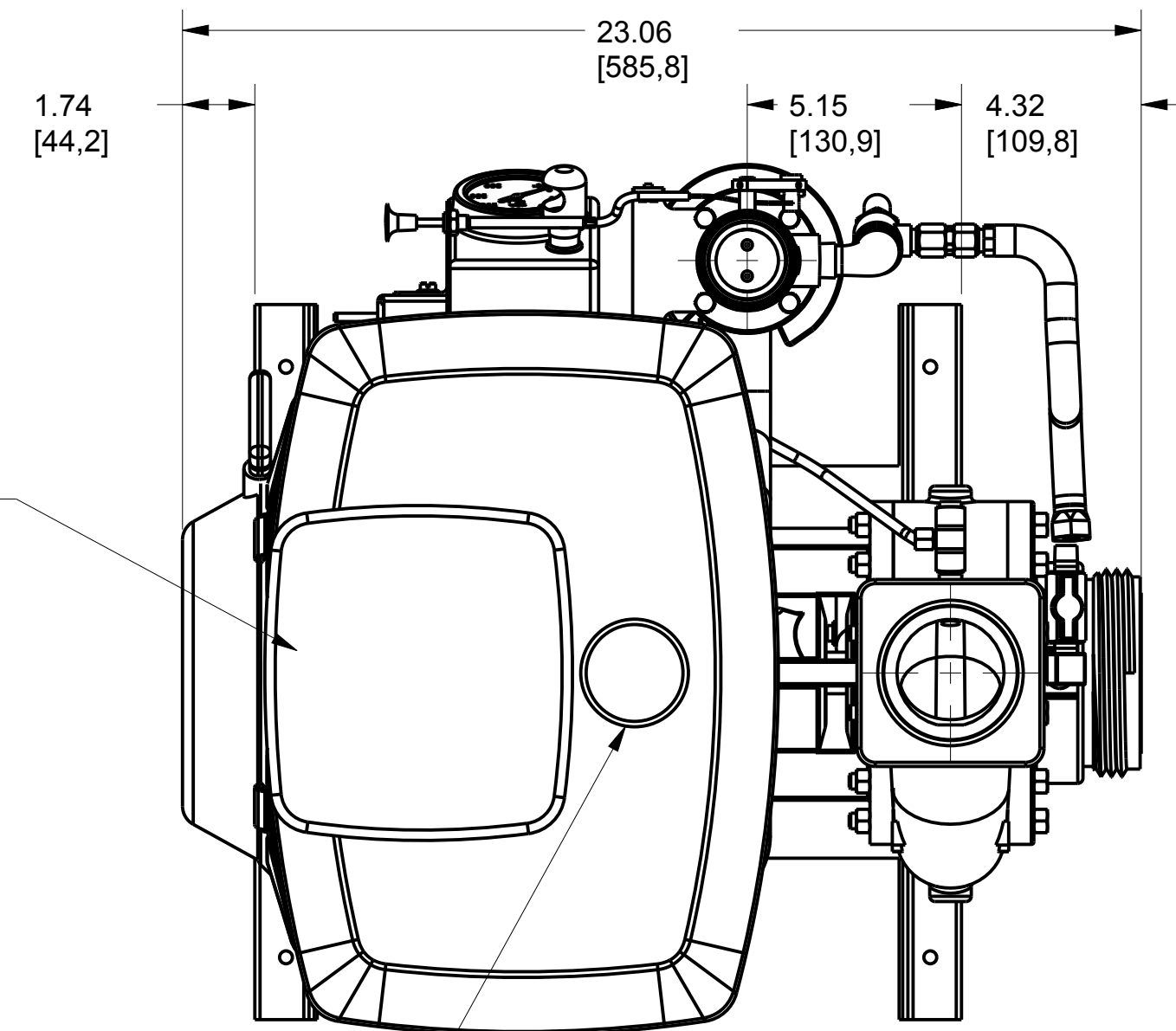

ENGINE AIR CLEANER

FUEL FILL

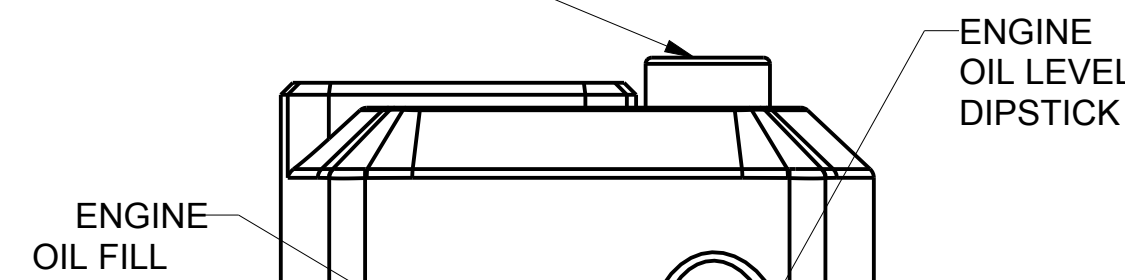

ENGINE OIL LEVEL DIPSTICK

ENGINE OIL FILL

2.5" NPT DISCHARGE FLANGE
ALSO AVAILABLE: 2.0" NPT, 3.0" NPT, 1.5" NPT
BSP FLANGES ALSO AVAILABLE UPON REQUEST

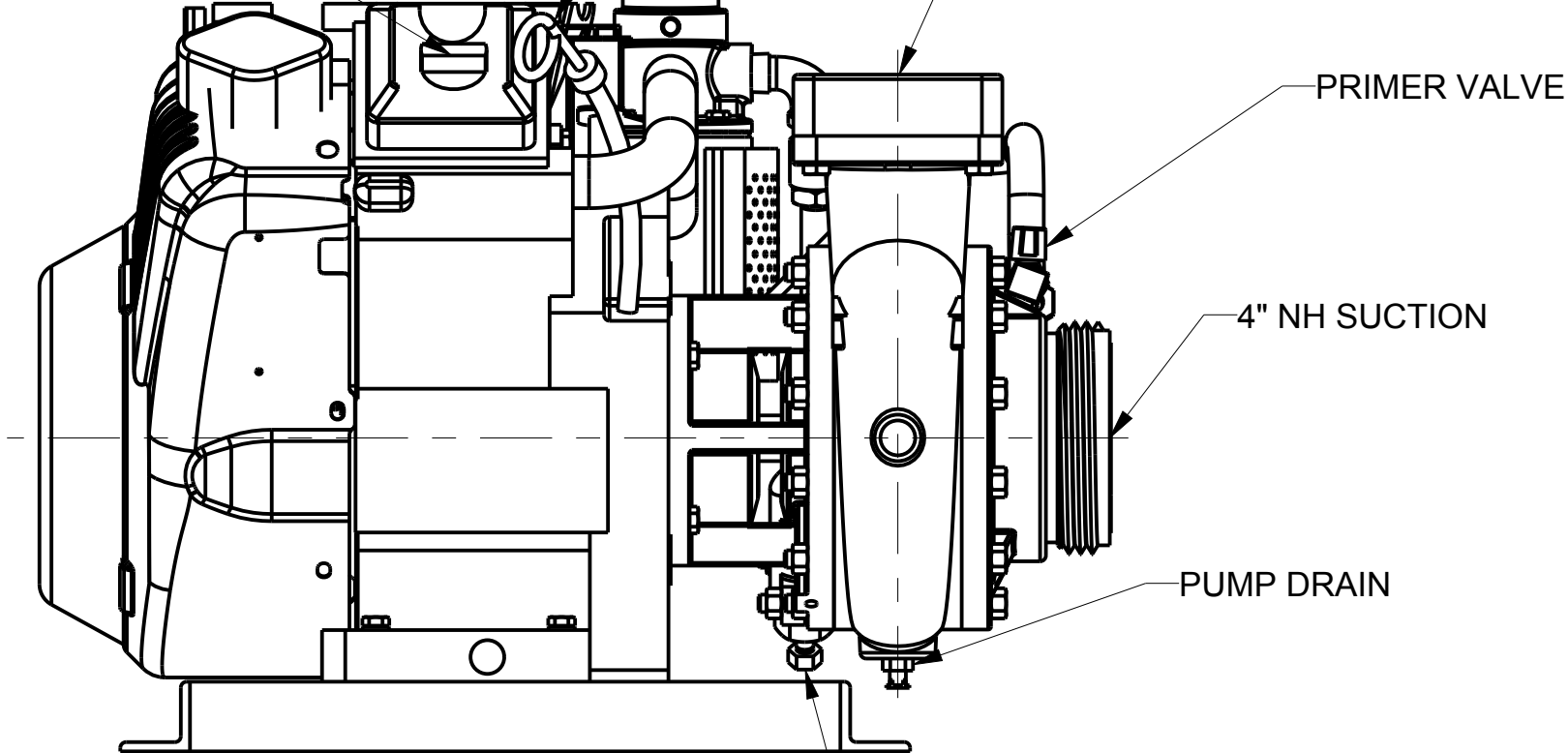

PRIMER VALVE

4" NH SUCTION

PUMP DRAIN

PACKING ADJUSTMENT
OPTIONAL MECHANICAL SEAL ALSO AVAILABLE

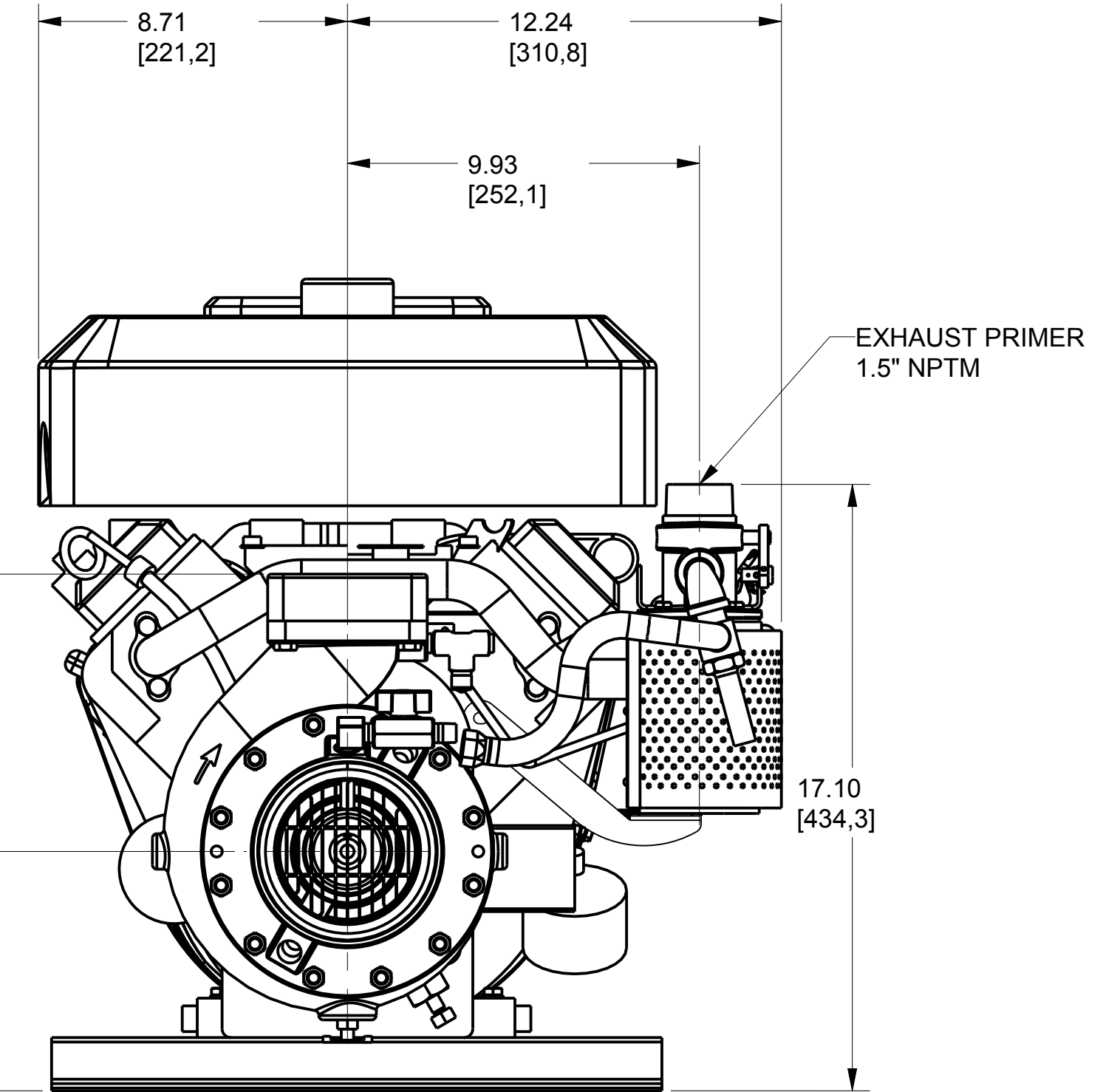

EXHAUST PRIMER
1.5" NPTM

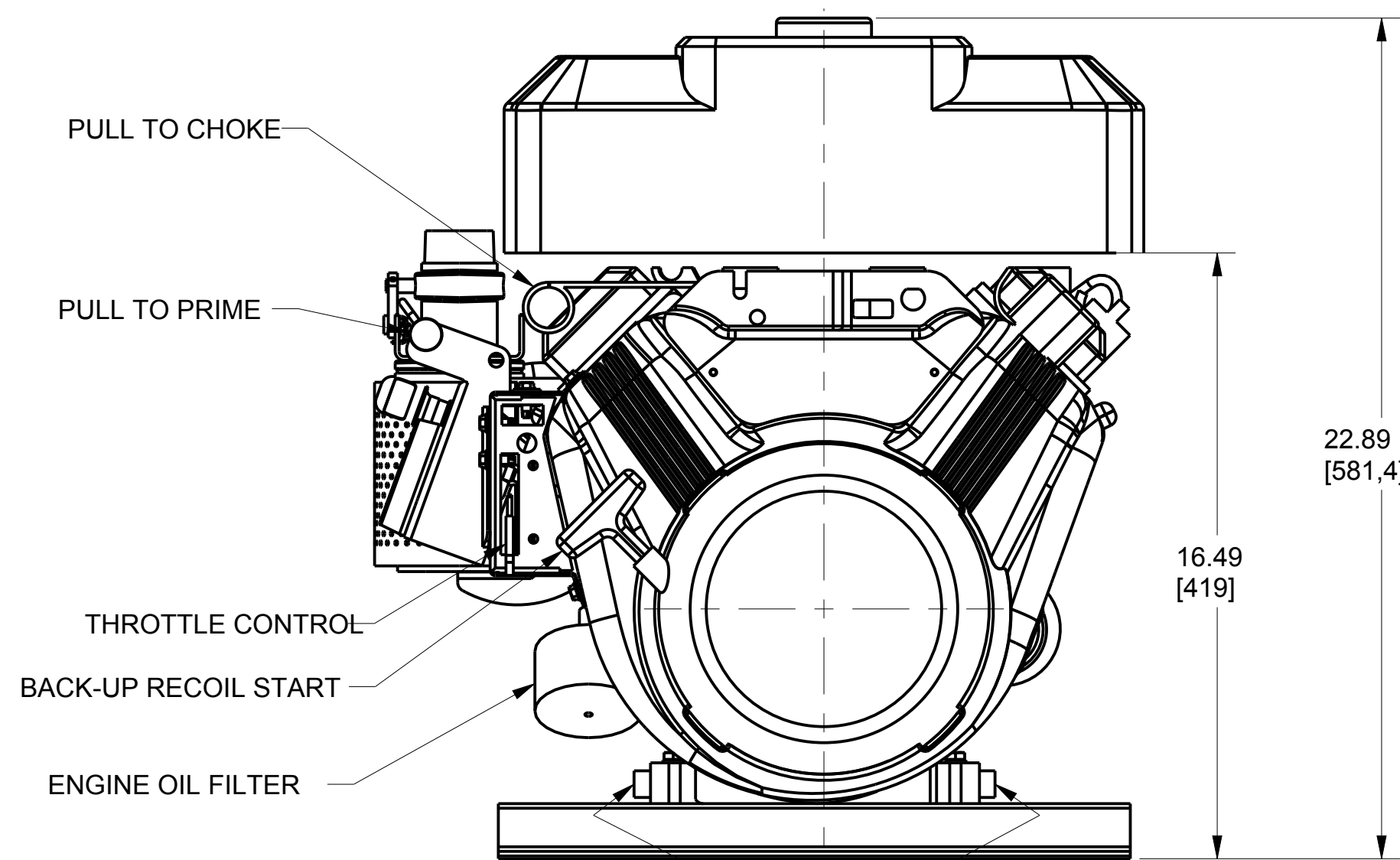

PULL TO CHOKE

PULL TO PRIME

THROTTLE CONTROL

BACK-UP RECOIL START

ENGINE OIL FILTER

ENGINE OIL DRAIN

22.89 [581.4]

16.49 [419]

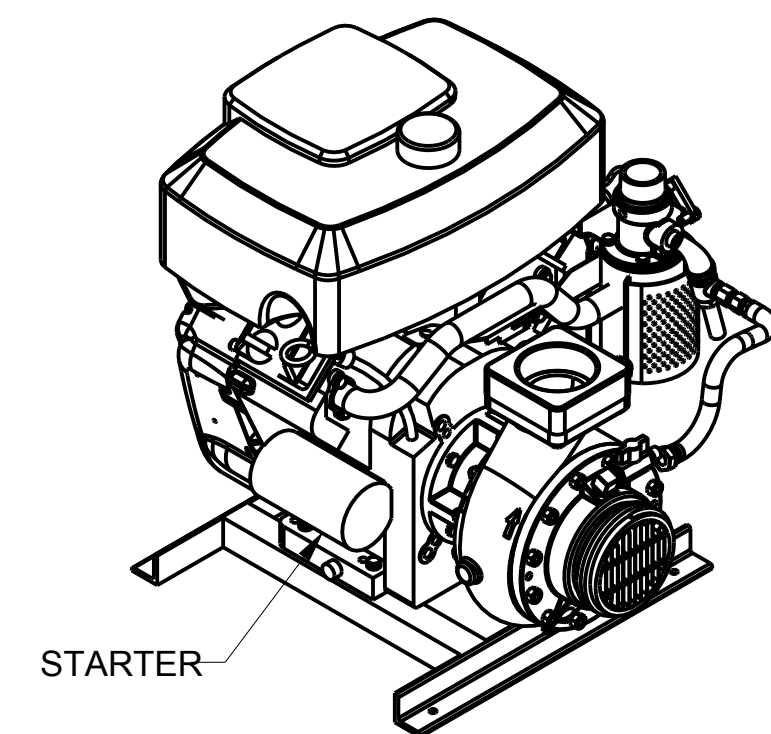

STARTER

SCALE 1/8

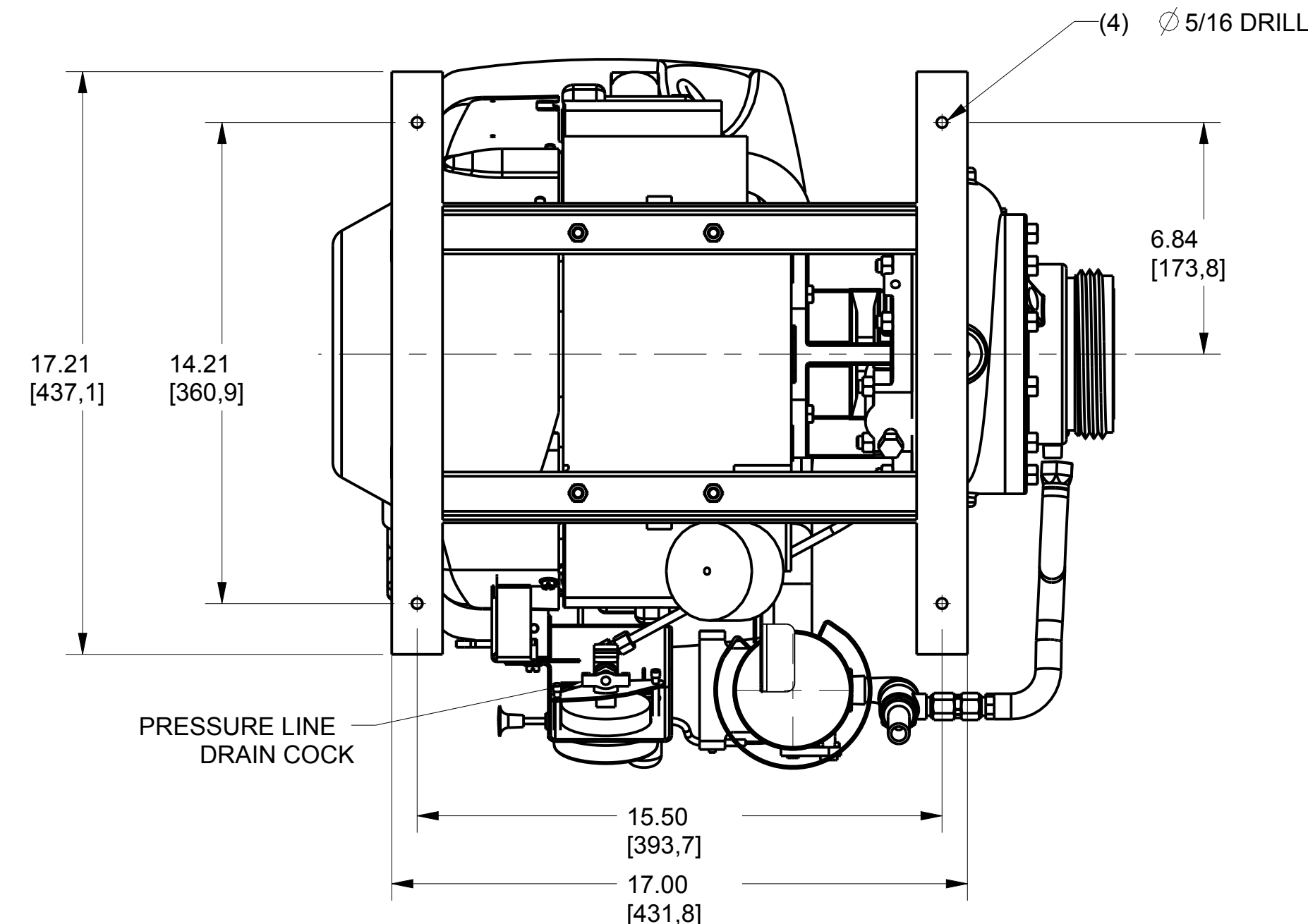

(4) Ø 5/16 DRILL

17.21 [437.1]

14.21 [360.9]

6.84 [173.8]

15.50 [393.7]

17.00 [431.8]

PRESSURE LINE
DRAIN COCK

APPROXIMATE WEIGHT: 227 LBS
(103 KG)

REMOVE SHARP EDGES

INCH [MILLIMETER]



OLD PART NO.

TOLERANCE EXCEPT AS NOTED

W.S. Darley & Co. ITASCA, IL - CHIPPEWA FALLS, WI

MATERIAL DESCRIPTION:

MATERIAL NO.

PATTERN NO.

HE 18HP COOLER/ CLEANER VANGUARD W/TANK - DIMENSIONAL

THIS DESIGN IS THE PROPERTY OF W.S. DARLEY AND CO. - UNAUTHORIZED REPRODUCTION IS PROHIBITED

DO NOT SCALE PRINT

DRY AAN CHKD TED TRCD

DATE 25-May-07 SCALE 1/4

DHD1103

MODEL NAME: DHD1103
MFL CREATED: 3/16/07
SHEET: 1/1