

WEIGHT, DRY, WITH COMPONENTS SHOWN = 225 POUNDS

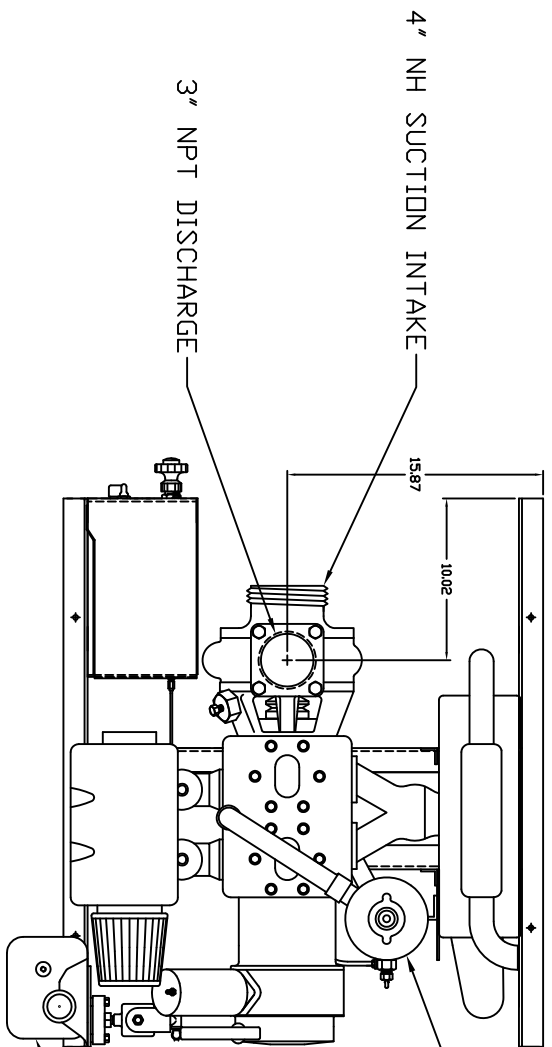

ADD 50% ANTIFREEZE/50% WATER HERE  
HEAT EXCHANGER W/ INTEGRAL EXPANSION TANK

LARGE OIL RESERVOIR  
USE HIGH QUALITY 2-CYCLE OIL  
FORMULATED FOR AIR COOLED ENGINES  
(NOT MARINE)

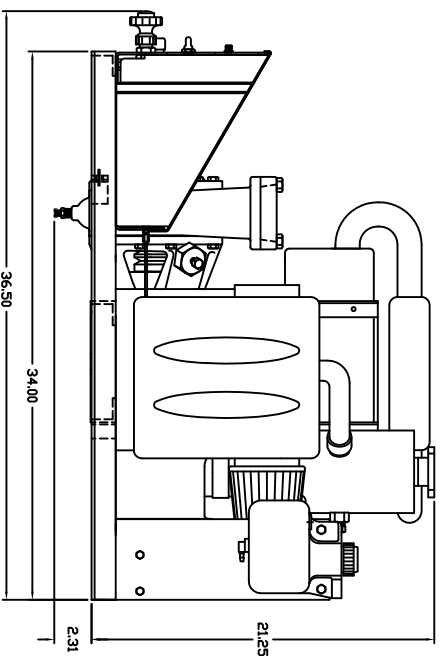
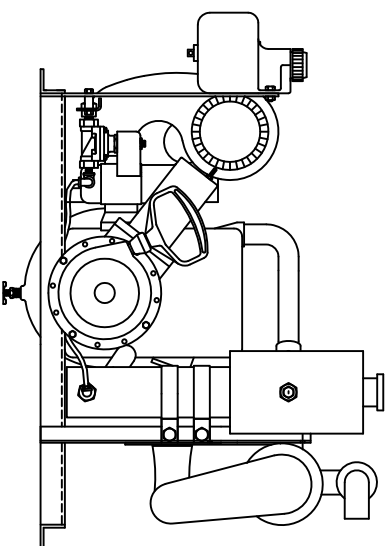

THE DESIGN IS THE PROPERTY OF HEGARS PUMPING UNIT ALL RIGHTS RESERVED NO REPRODUCTION OR DISTRIBUTION WITHOUT PERMISSION		ALL DIMENSIONS IN INCHES UNLESS NOTED		DO NOT SCALE PRINT	
PART NO. 1000000000	PATENT NO. 1000000000	DATE 8-21-81	SCALE 1/4"	DRAWN BY J.S. DARLEY & CO.	CHECKED BY HEGARS PUMPING UNIT
DIMENSIONAL DRAWING DH100502					