

NO.	DESCRIPTION	PART NO.	QTY.
1	3" BASIC RELIEF VALVE	-	2
2	ASSY - 1.12 AIR CYLINDER	-	1
3	ASSY - 1.75 AIR CYLINDER	-	1
4	ASSY - FLANGE - 6 WELD, O-RING	-	2
5	ASSY - FLANGE COVER, BLANK	-	4
6	ASSY - FLANGE, 4" WELD, STEEL	-	1
7	ASSY - FLANGE, 5" WELD, CRS	-	2
8	BODY - STAGING VALVE	-	1
9	COVER - DISCHARGE HEAD	-	1
10	EXTENSION - SUCTION, LDM	-	2
11	FLANGE - 2.5, WELD, O-RING	-	3
12	FLANGE - 3" WELD, O-RING	-	2
13	FLANGE - 4.00" WELD, O-RING	-	2
14	FLANGE - COMP, ISO 8667:1992(E)	-	2
15	GEARCASE - MIDSHIP, PUMP REAR	-	1
16	HEAT EXCHANGER - LDM TRANS	-	1
17	PUMP CASING - E	-	1

REVISIONS				
LTR	DESCRIPTION	DATE	CHG NO.	APPR'D

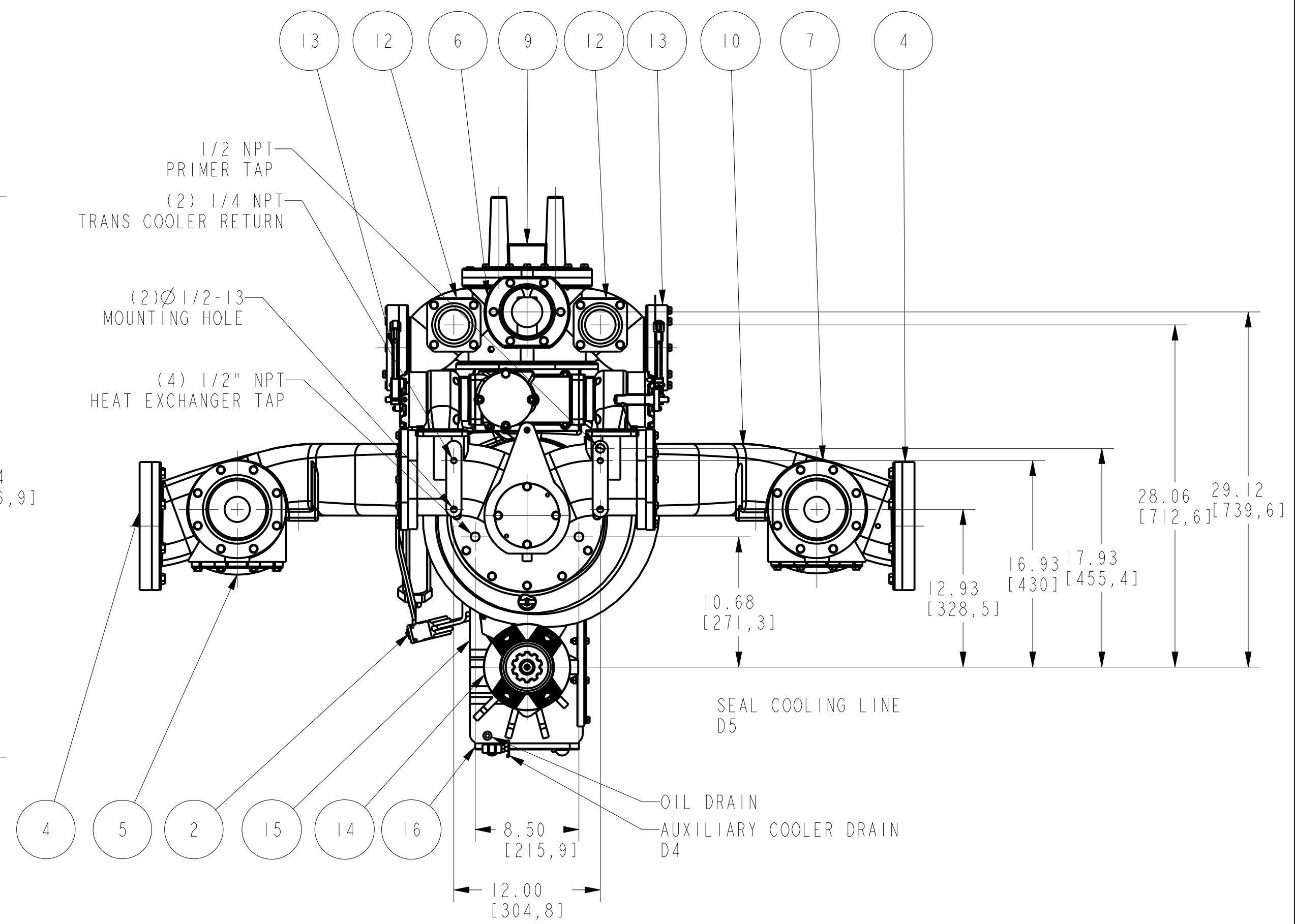
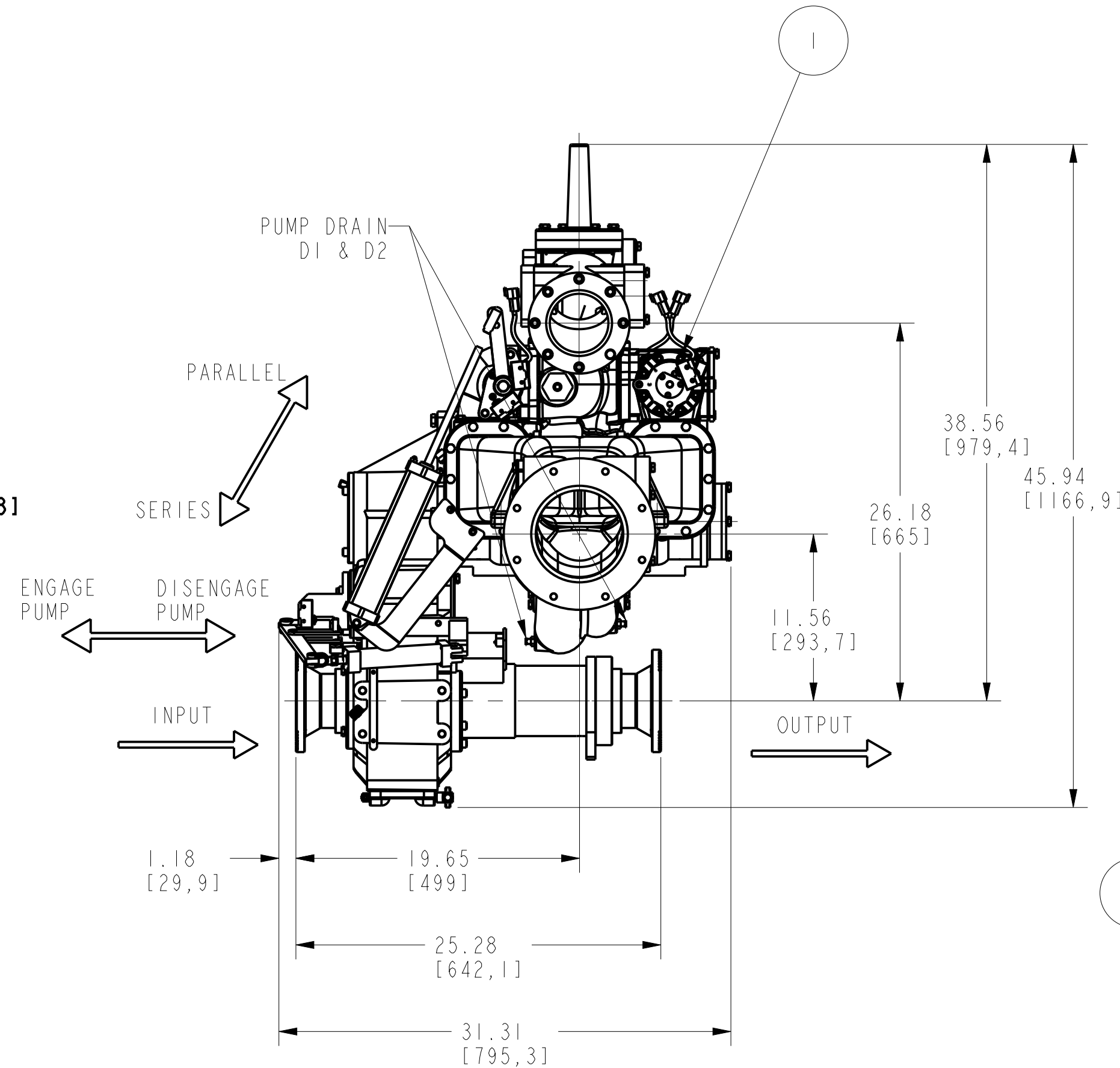
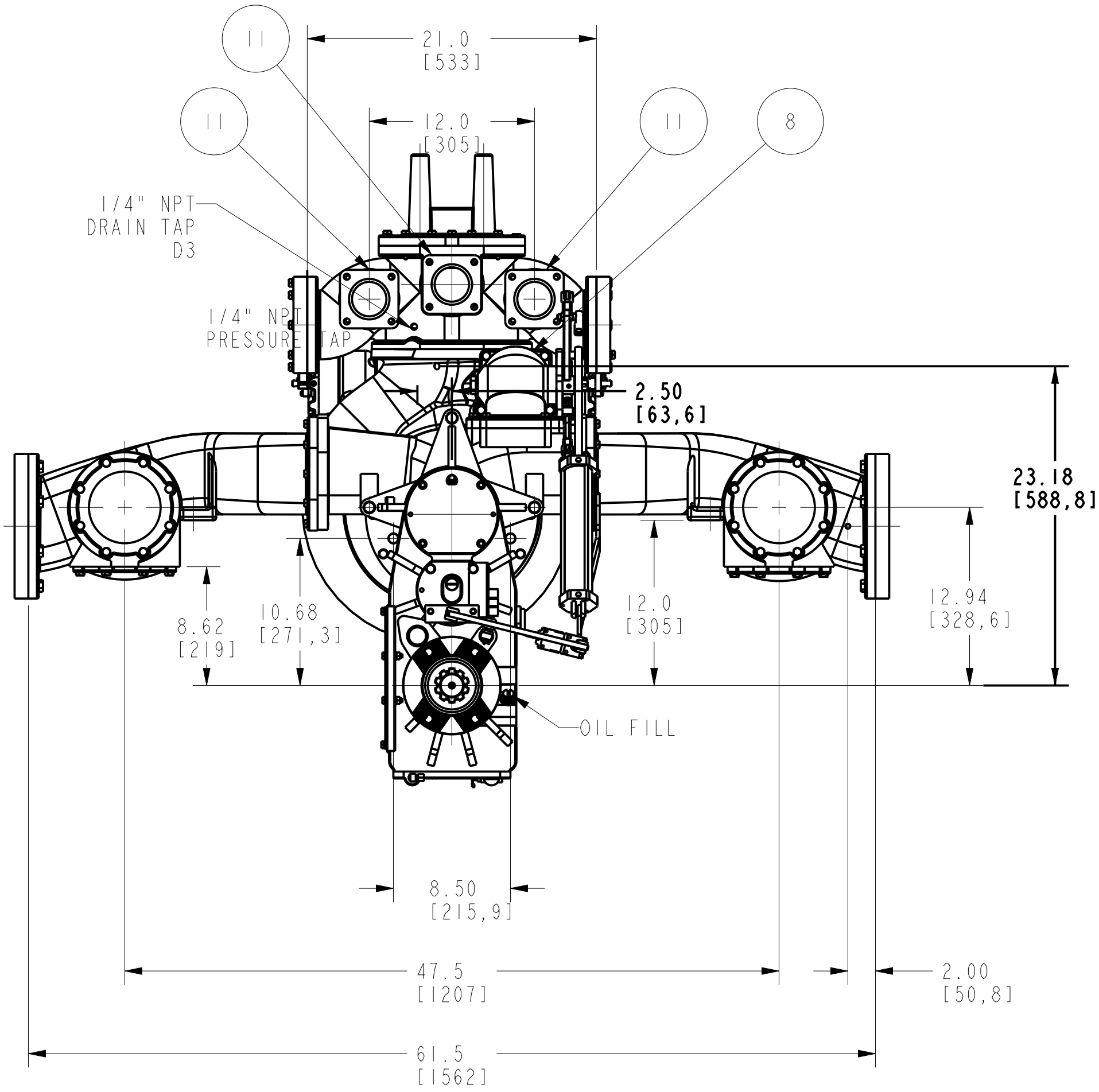
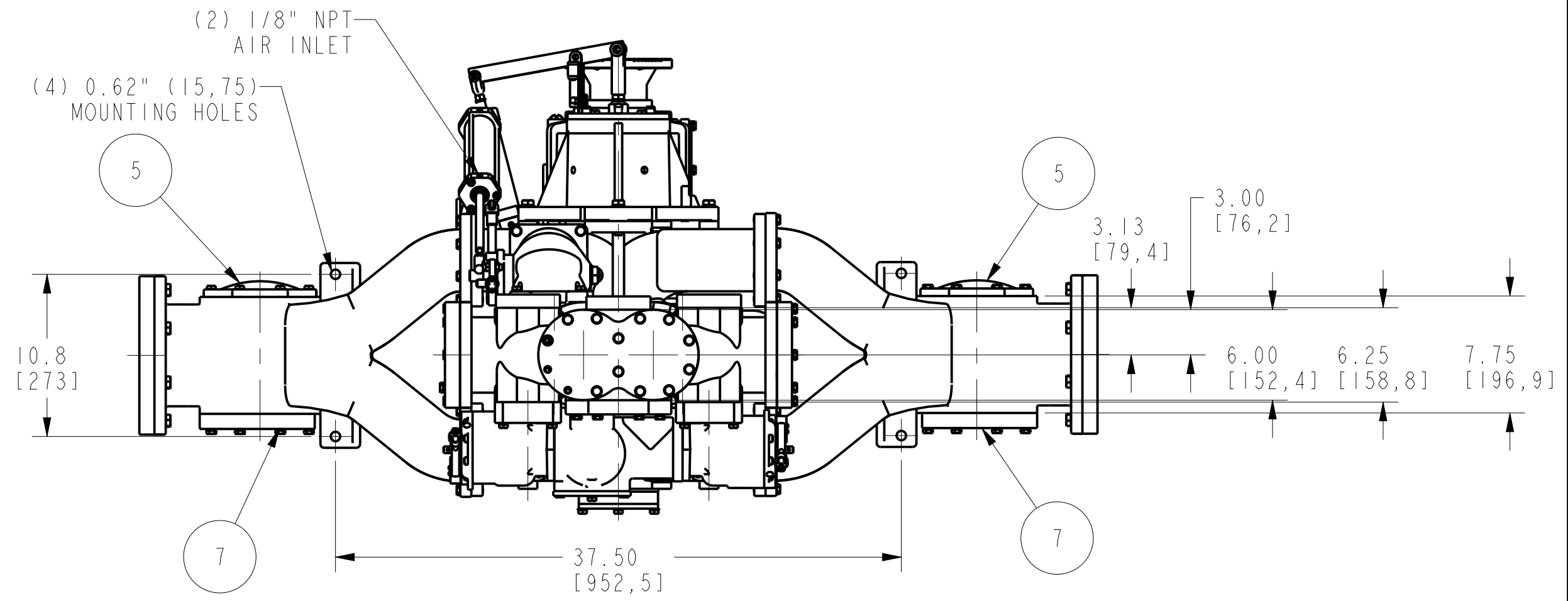
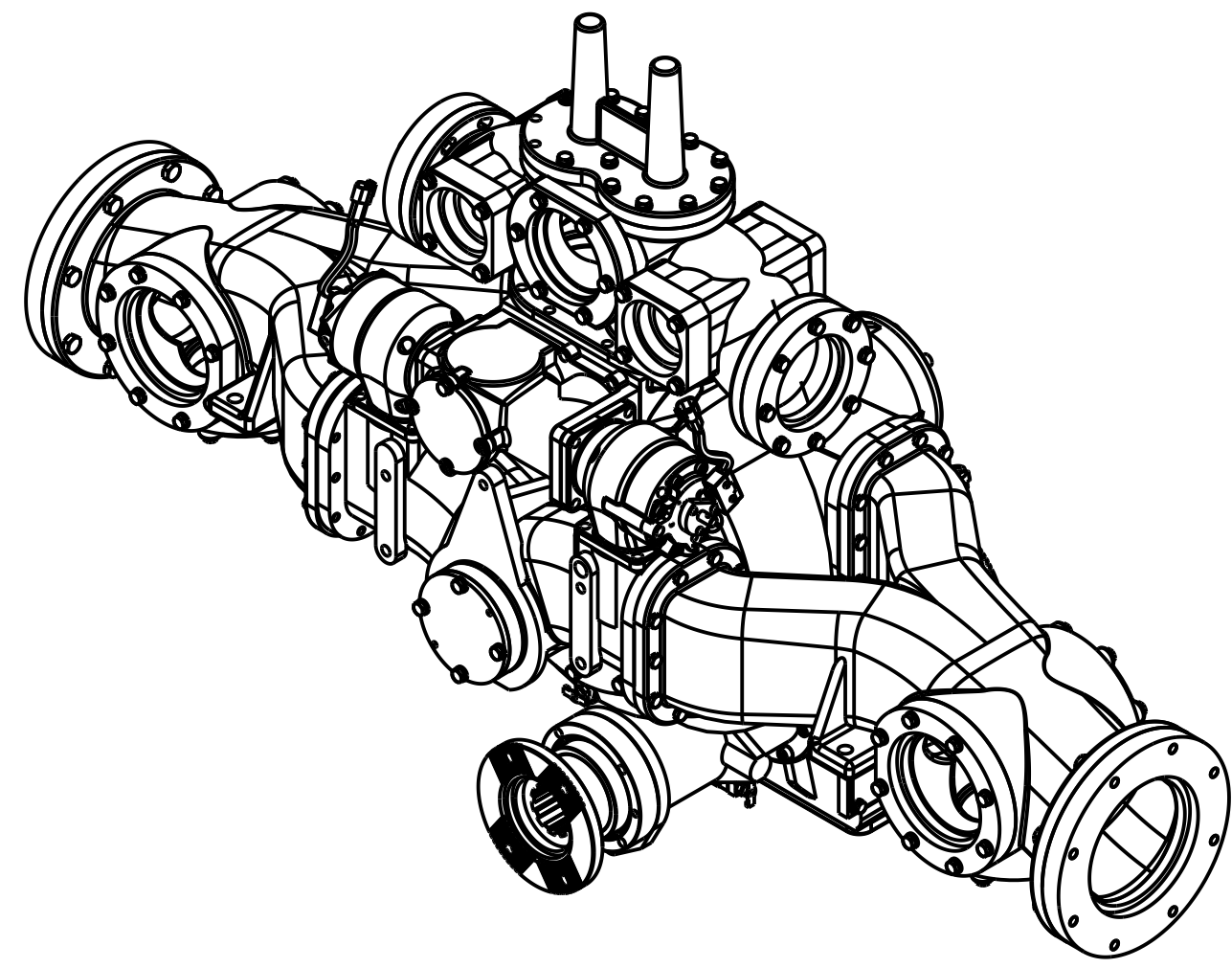

ENGINE ROTATION THIS VIEW

REMOVE SHARP EDGES		INCH (MILLIMETER)	OLD PART NO.	TOLERANCE EXCEPT AS NOTED	 W.S. Darley & Co. CHIPPewa FALLS, WI
MATERIAL DESCRIPTION:		MATERIAL NO.	PATTERN NO.	.00 ± .03 .000 ± .010 ANGLES #1"	
THIS DESIGN IS THE PROPERTY OF W.S. DARLEY AND CO. UNAUTHORIZED REPRODUCTION IS PROHIBITED.		ALL DIMENSIONS IN INCHES UNLESS NOTED		DR 'N' - CHWD MCR TRCD	DATE 13-May-10 SCALE 1/16 DED0055