

REVISIONS				
LTR	DESCRIPTION	DATE	CHG NO.	APPRD

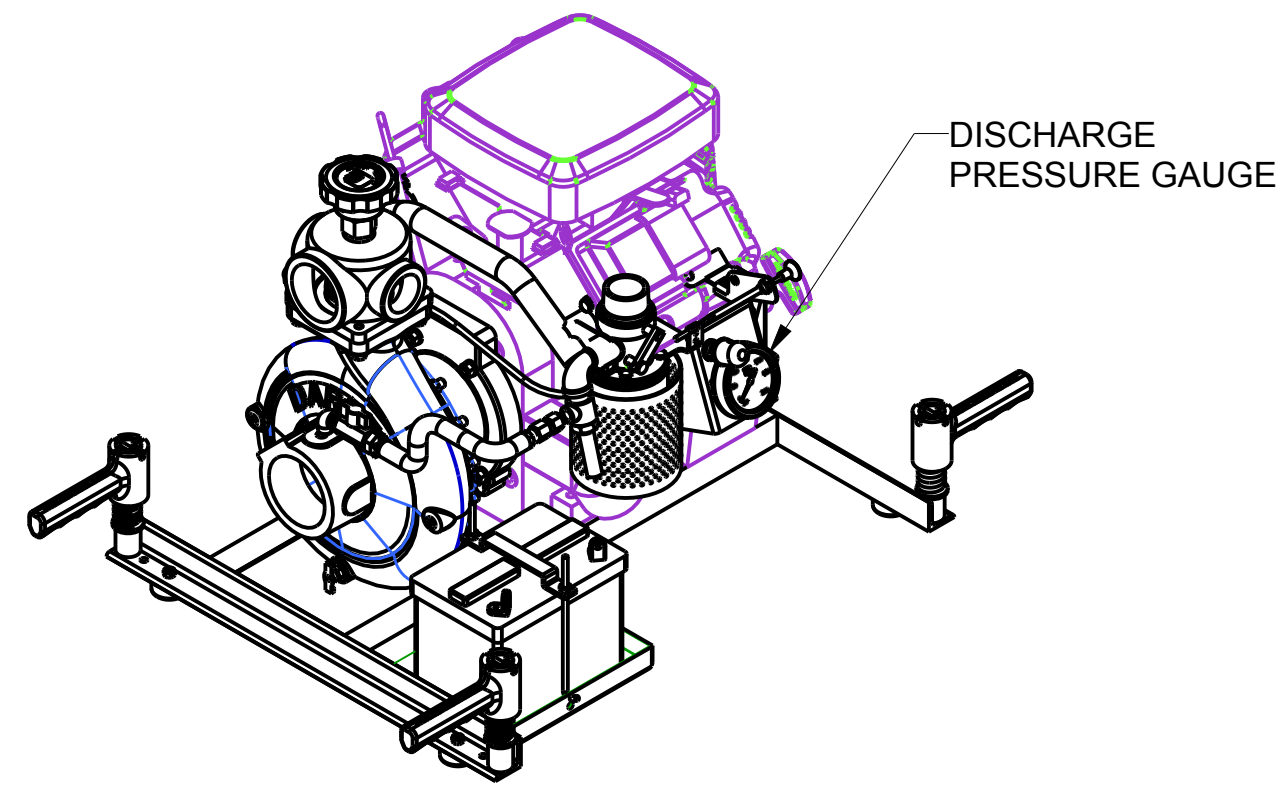

DISCHARGE PRESSURE GAUGE

SCALE 1/8

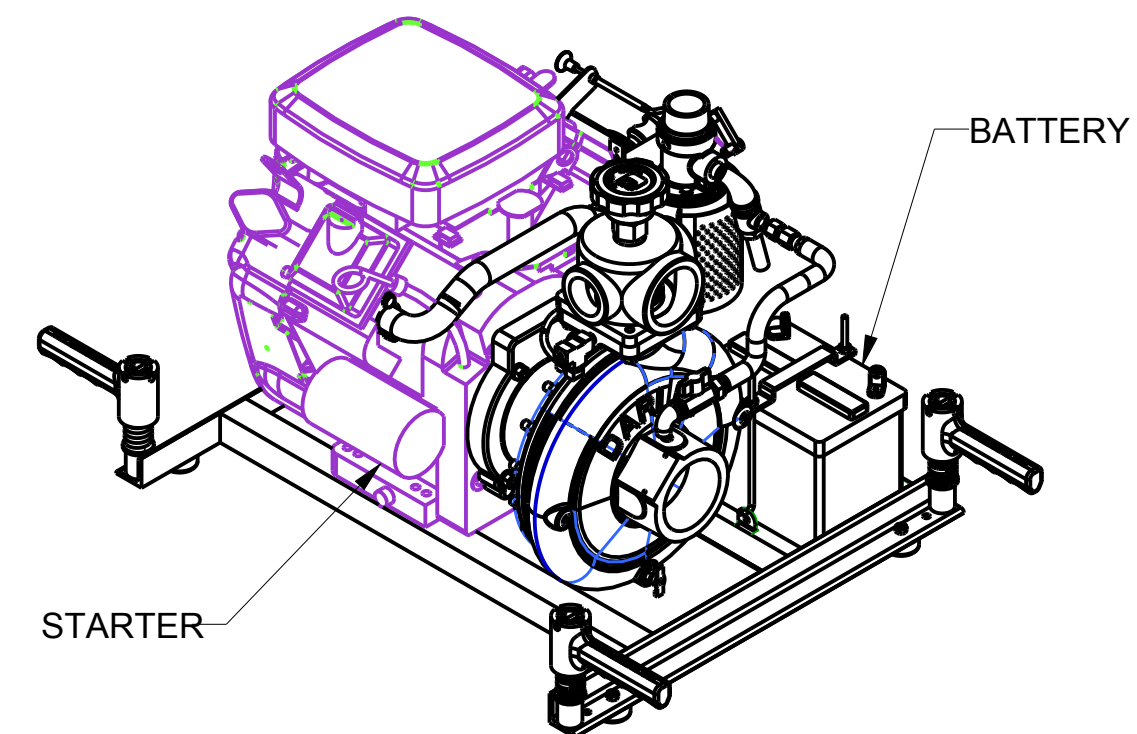
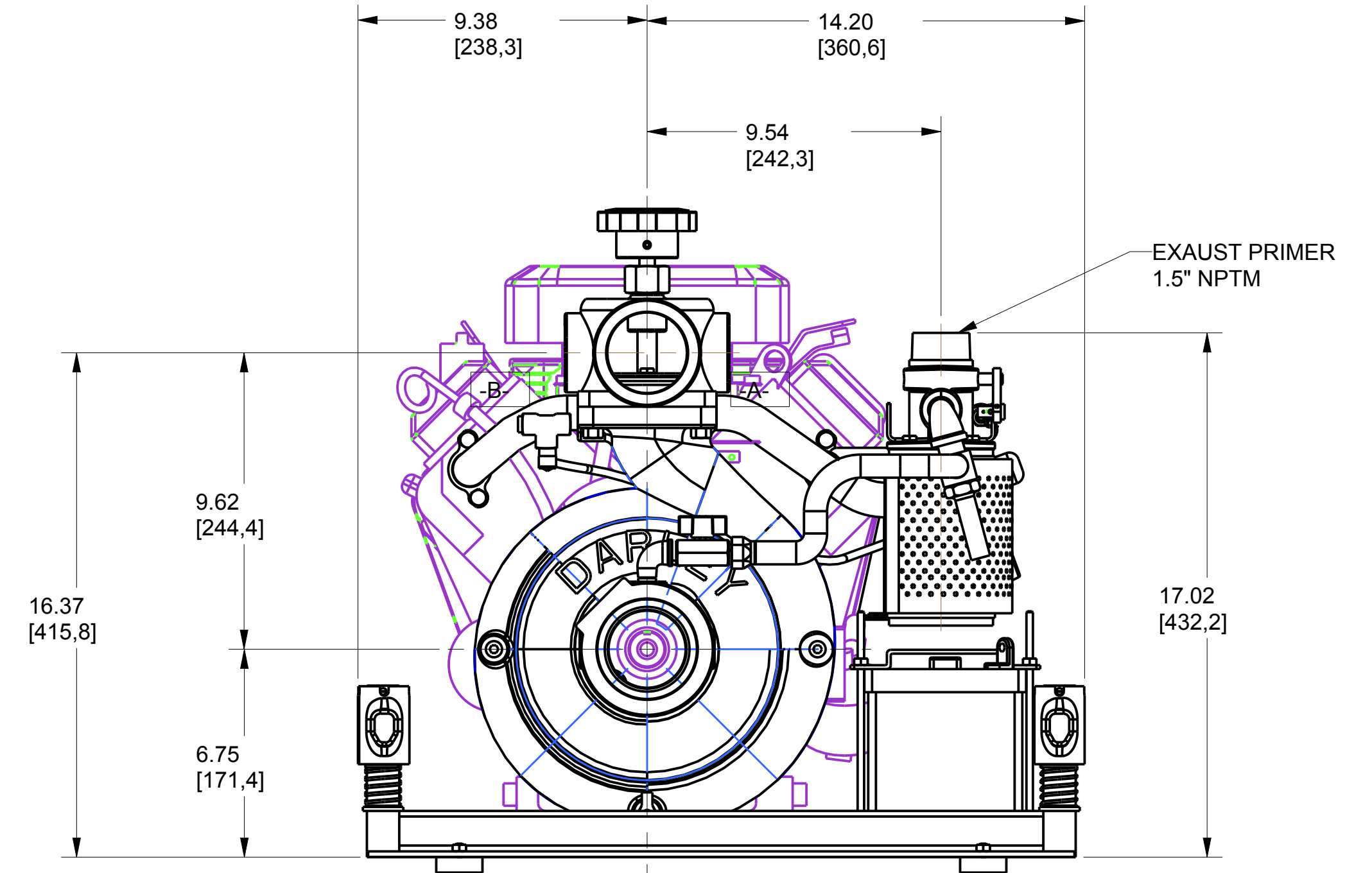
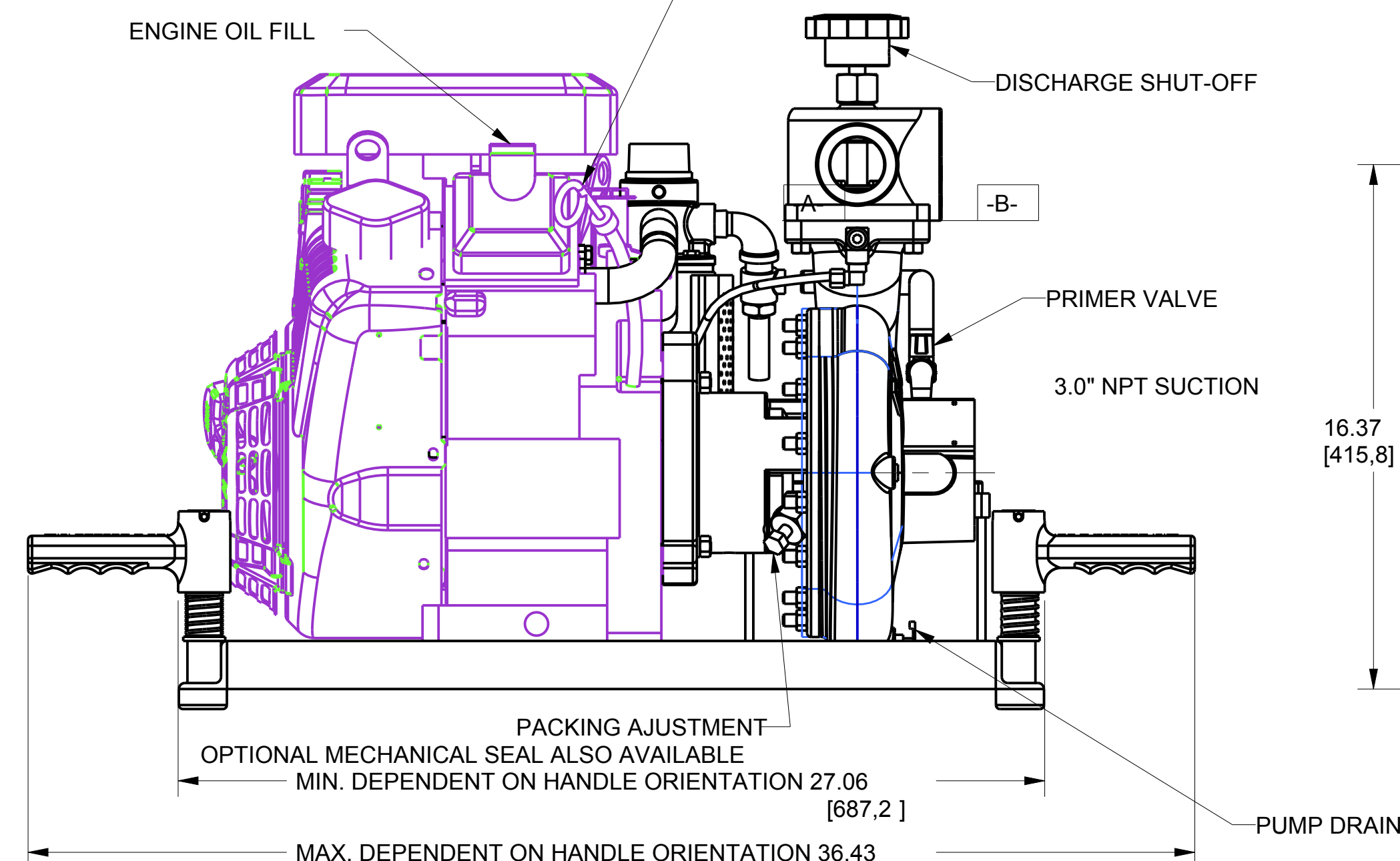
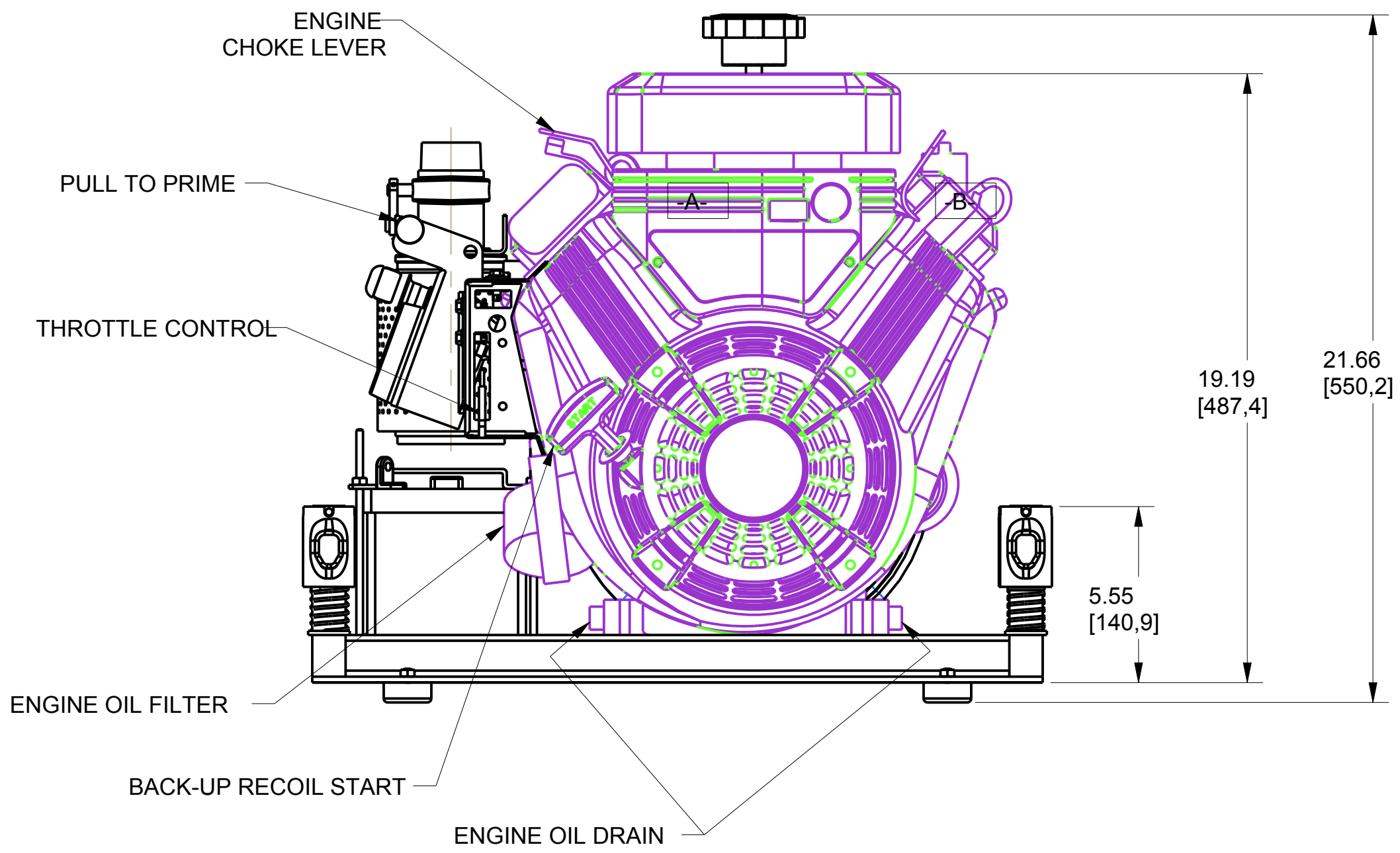
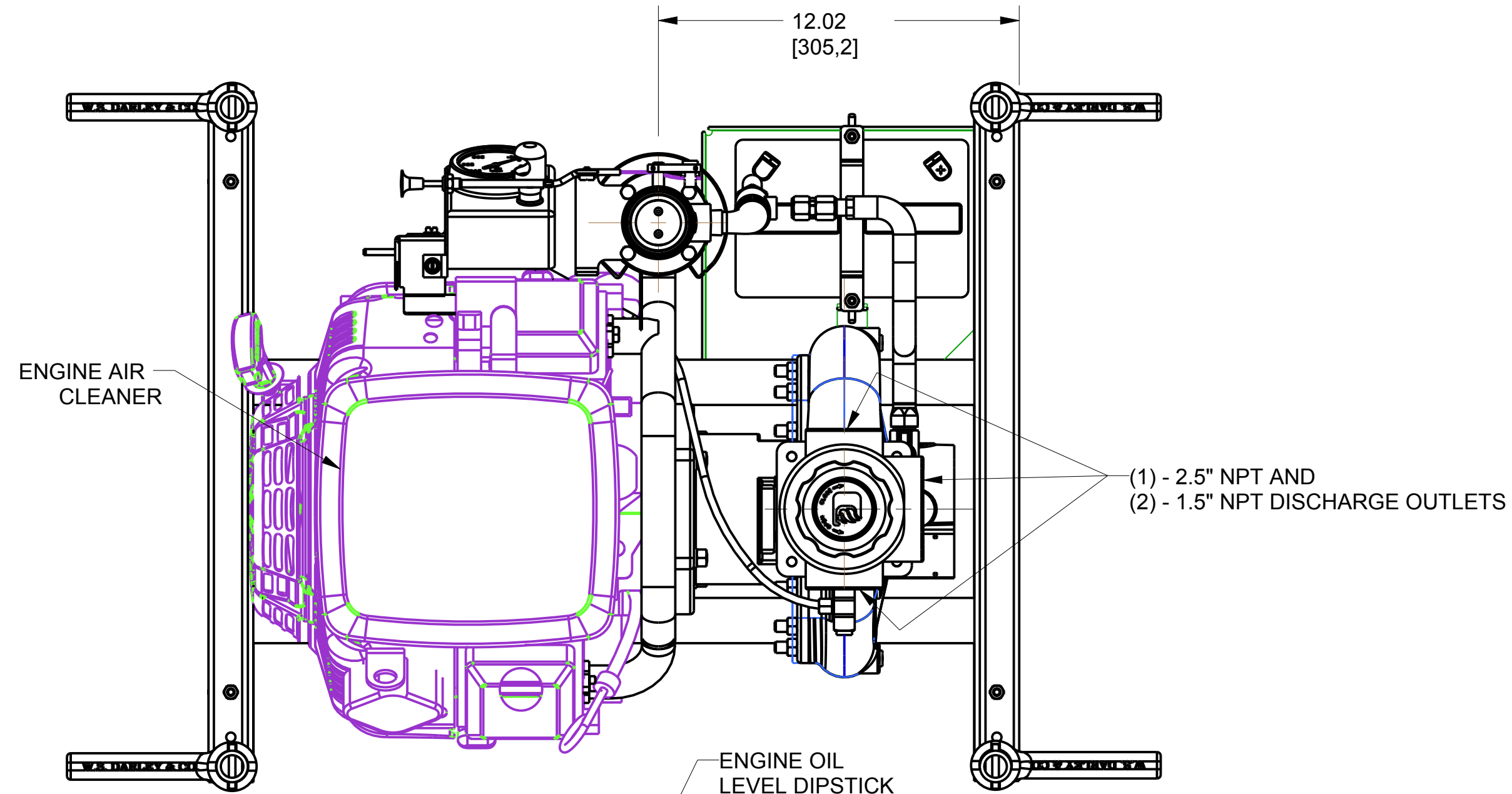

BATTERY

STARTER

SCALE 1/8

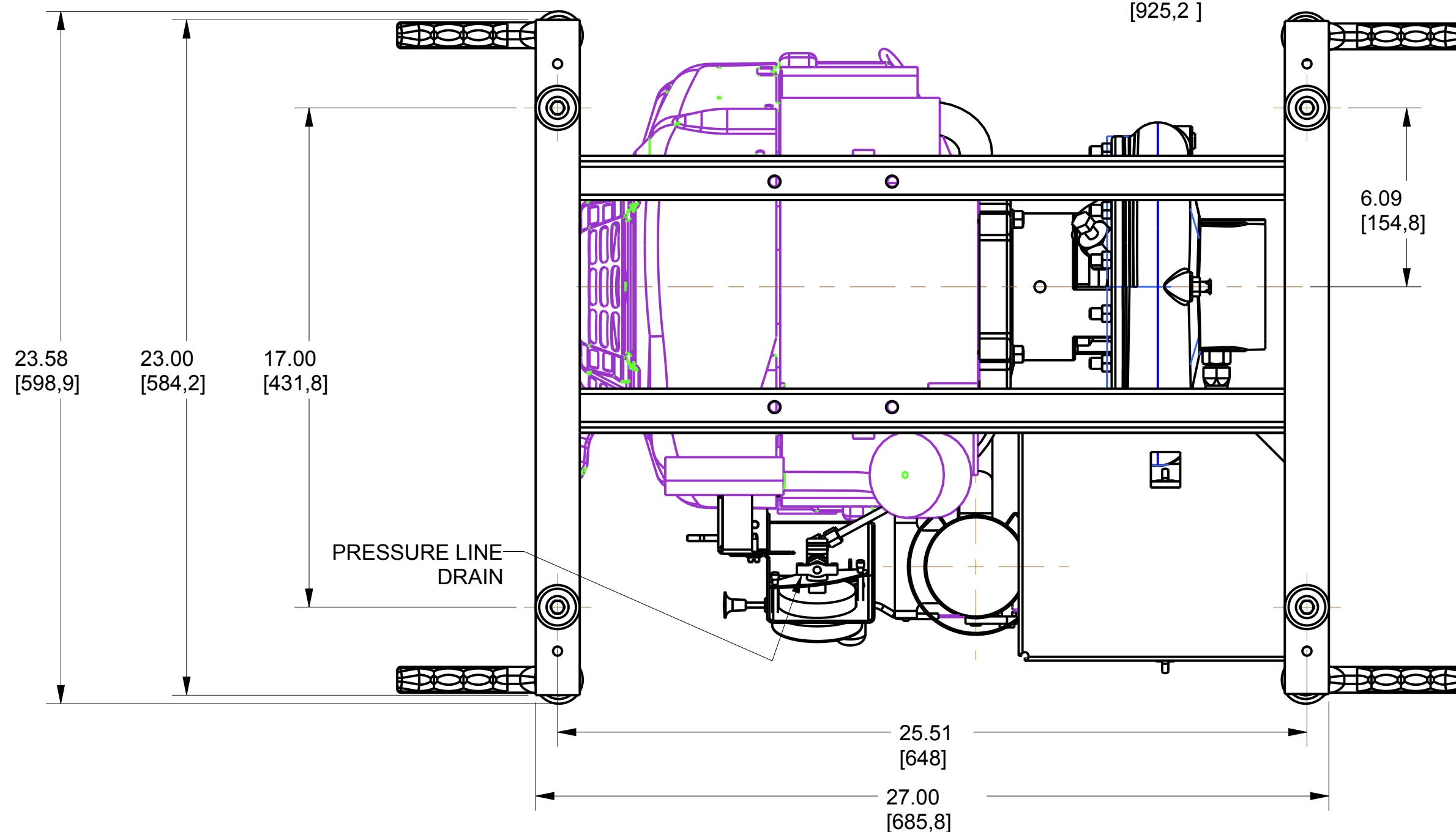

APPROXIMATE WEIGHT: 195 LBS (89KG)

REMOVE SHARP EDGES		INCH [MILLIMETER]		TOLERANCE EXCEPT AS NOTED 00 ±.03 2000 ±.010 ANGLES ±.1°		OLD PART NO.		DATE 24-May-07		SCALE 1/4	
MATERIAL DESCRIPTION: THIS DESIGN IS THE PROPERTY OF W.S. DARLEY AND CO. - UNAUTHORIZED REPRODUCTION IS PROHIBITED		MATERIAL NO.		PATTERN NO.		2BE 23 HP COOLER/CLEANER VANGUARD - DIMENSIONAL		DATE 24-May-07		SCALE 1/4	
DRN JWG		CHKD		TRCD		DO NOT SCALE PRINT		DATE 24-May-07		SCALE 1/4	
W.S. Darley & Co. ITASCA, IL - CHIPPEWA FALLS, WI		DBD0503		22MAR2007		1/1		D		DBD0503	