

REVISIONS				
LTR	DESCRIPTION	DATE	CHG NO.	APPR'D

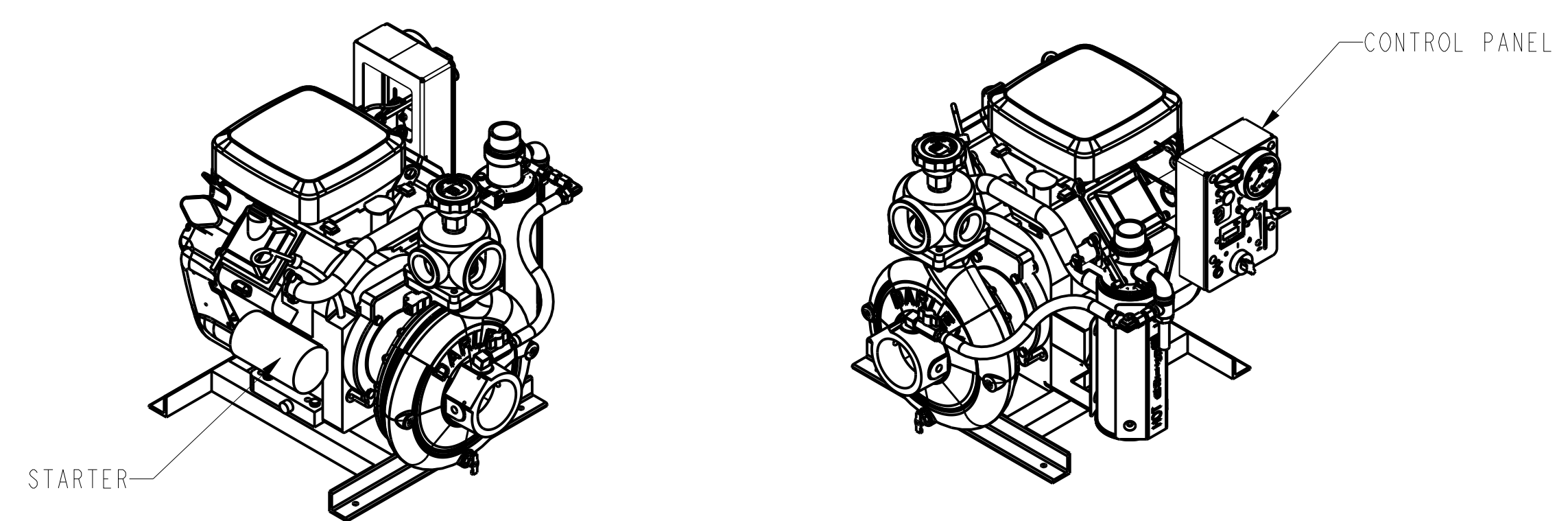

SCALE 1/8

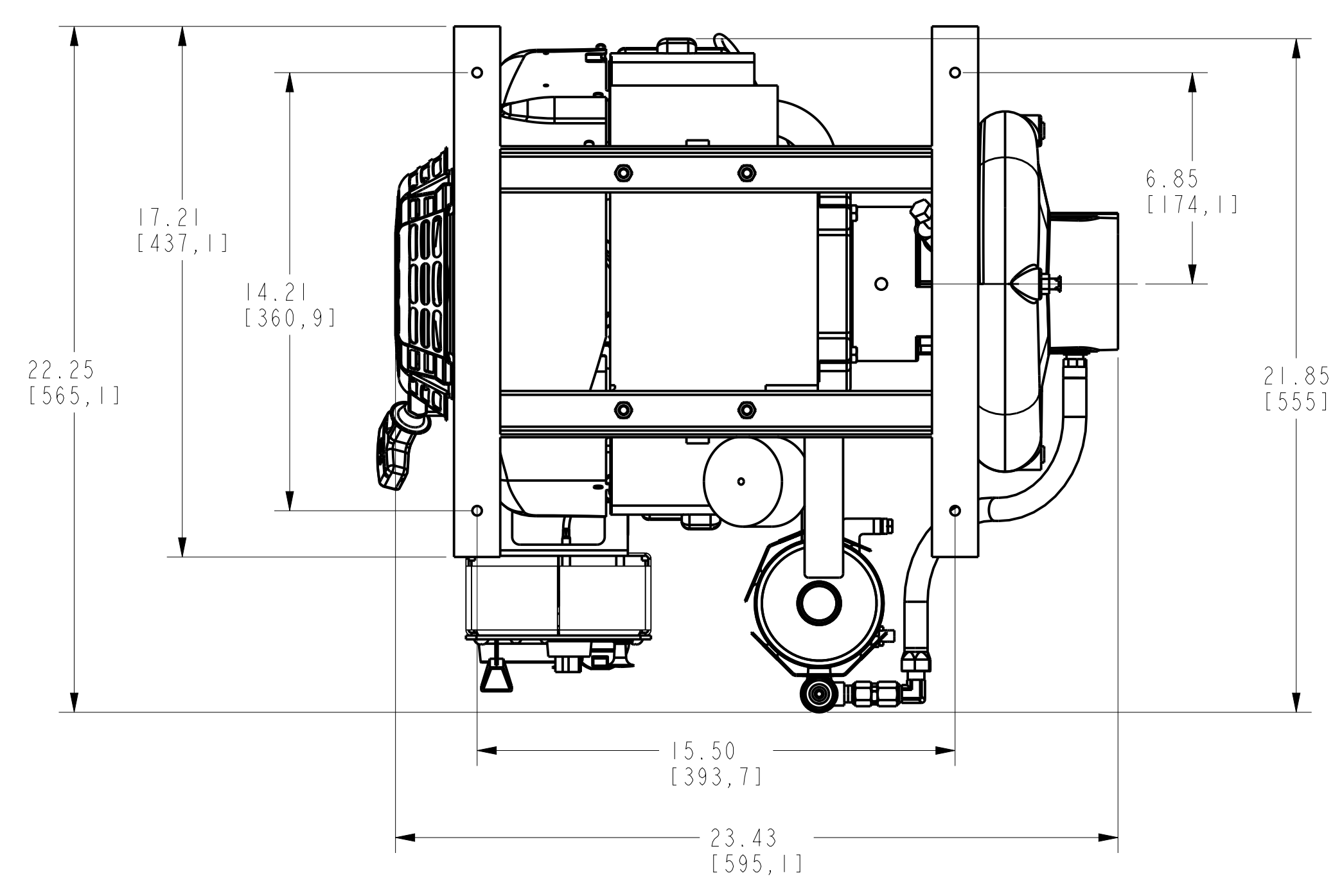
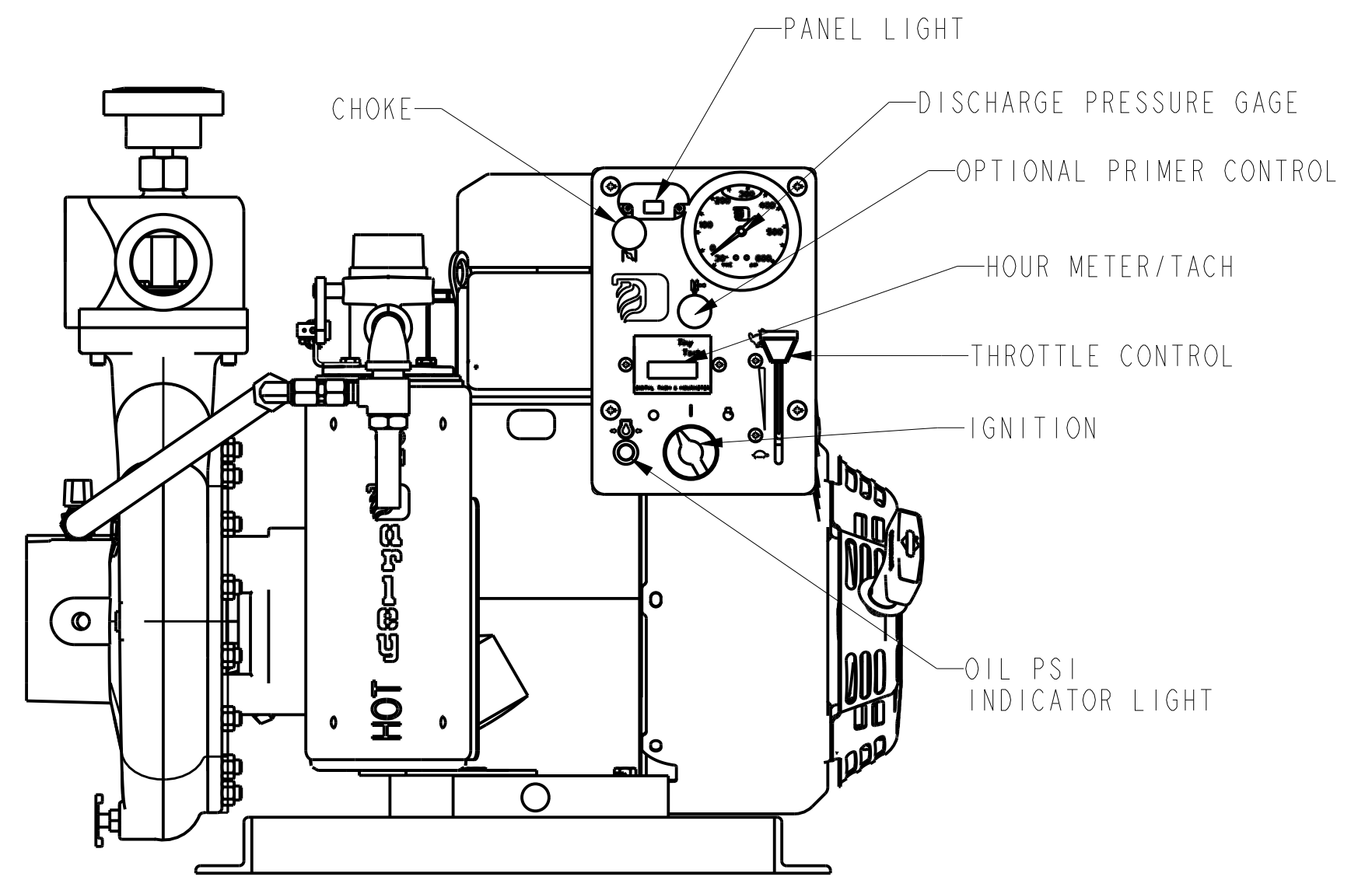
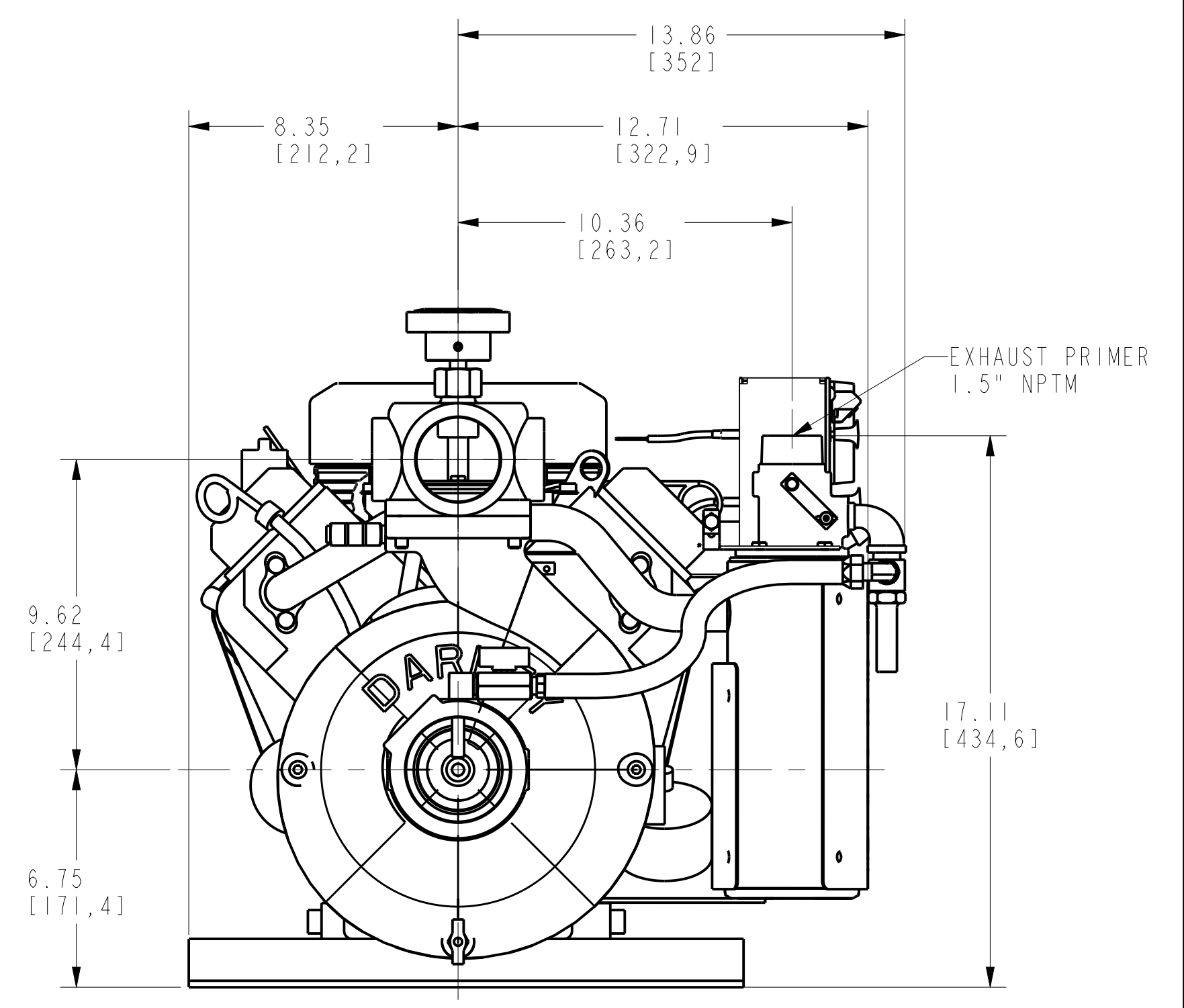
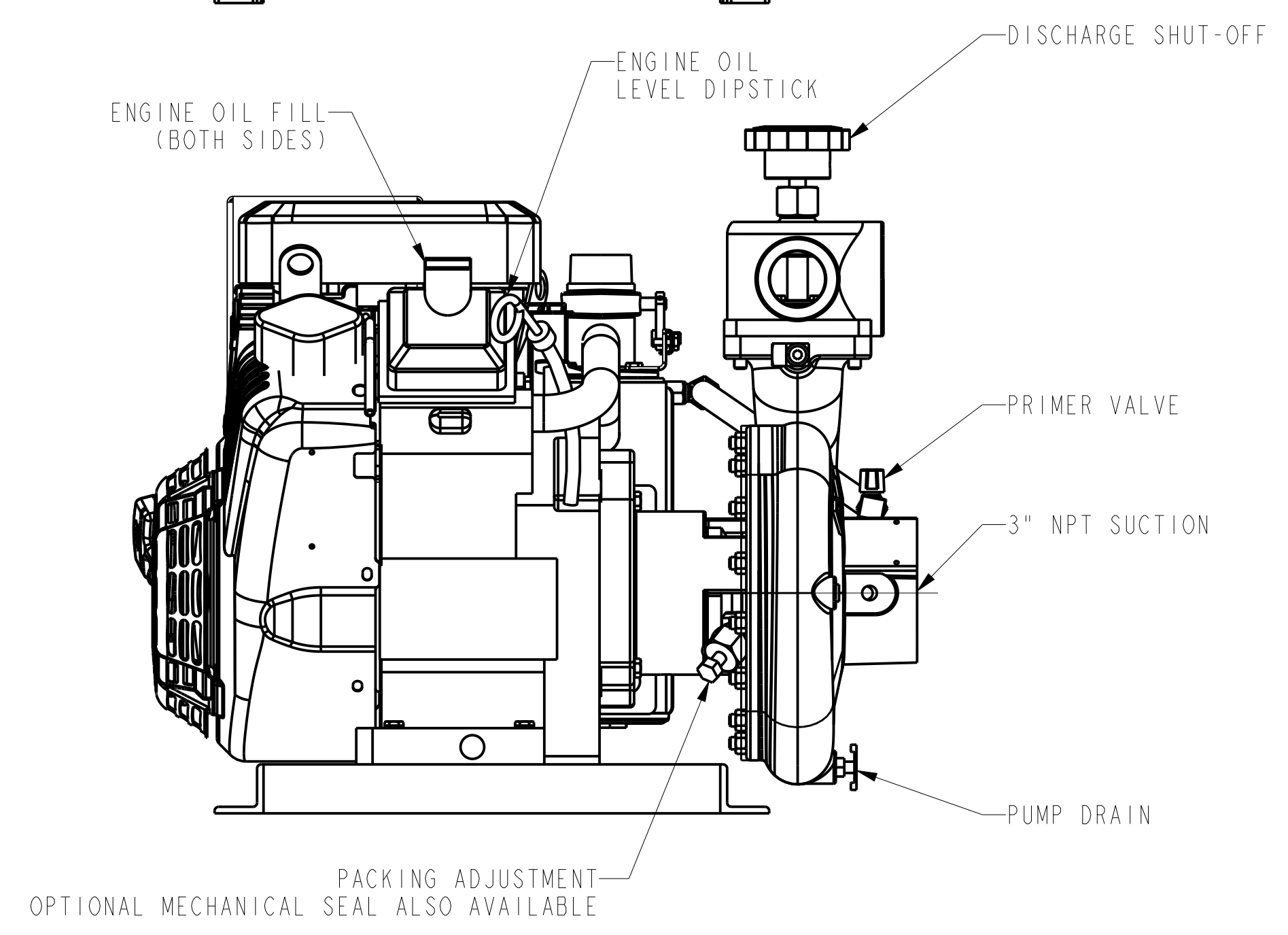
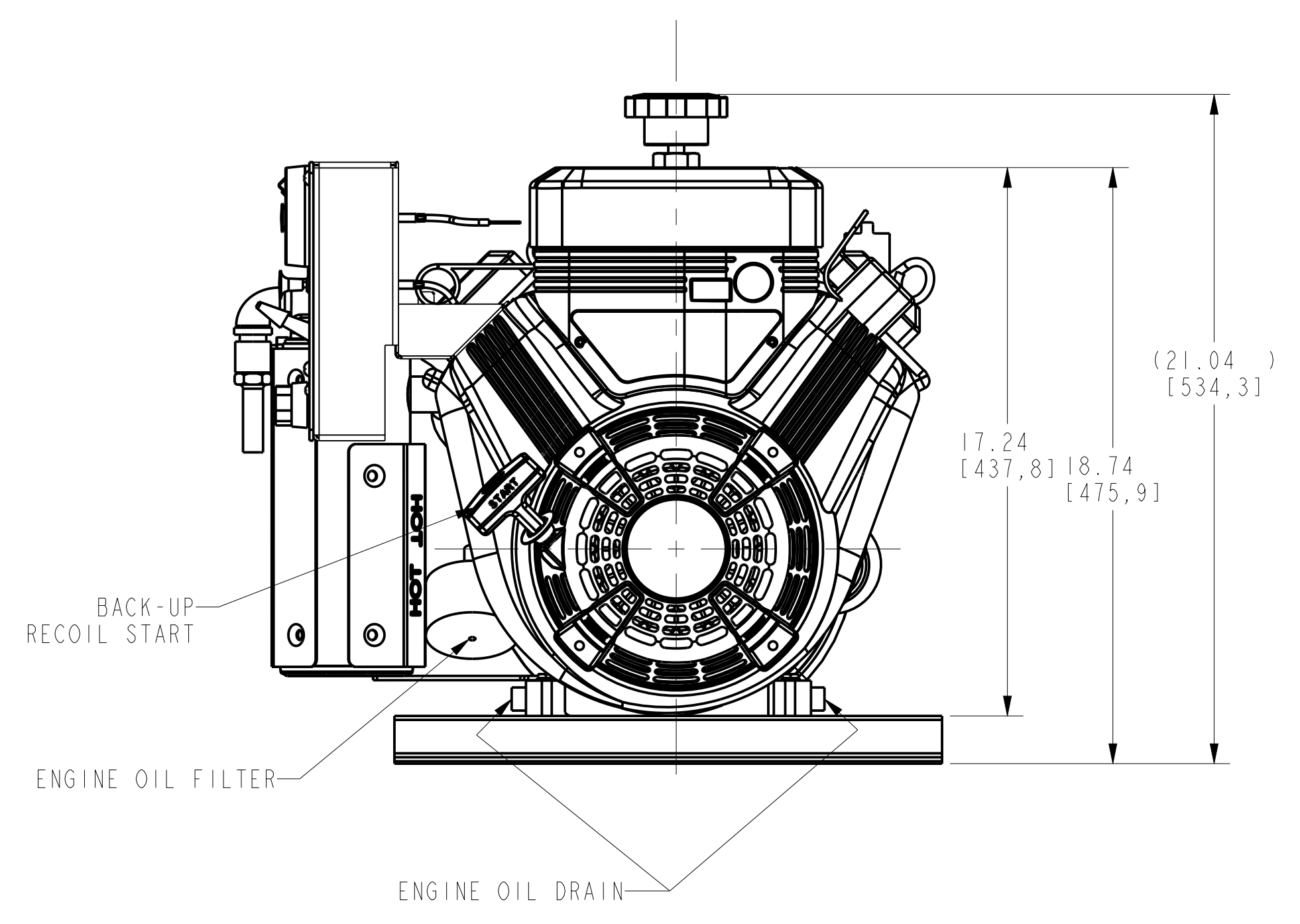
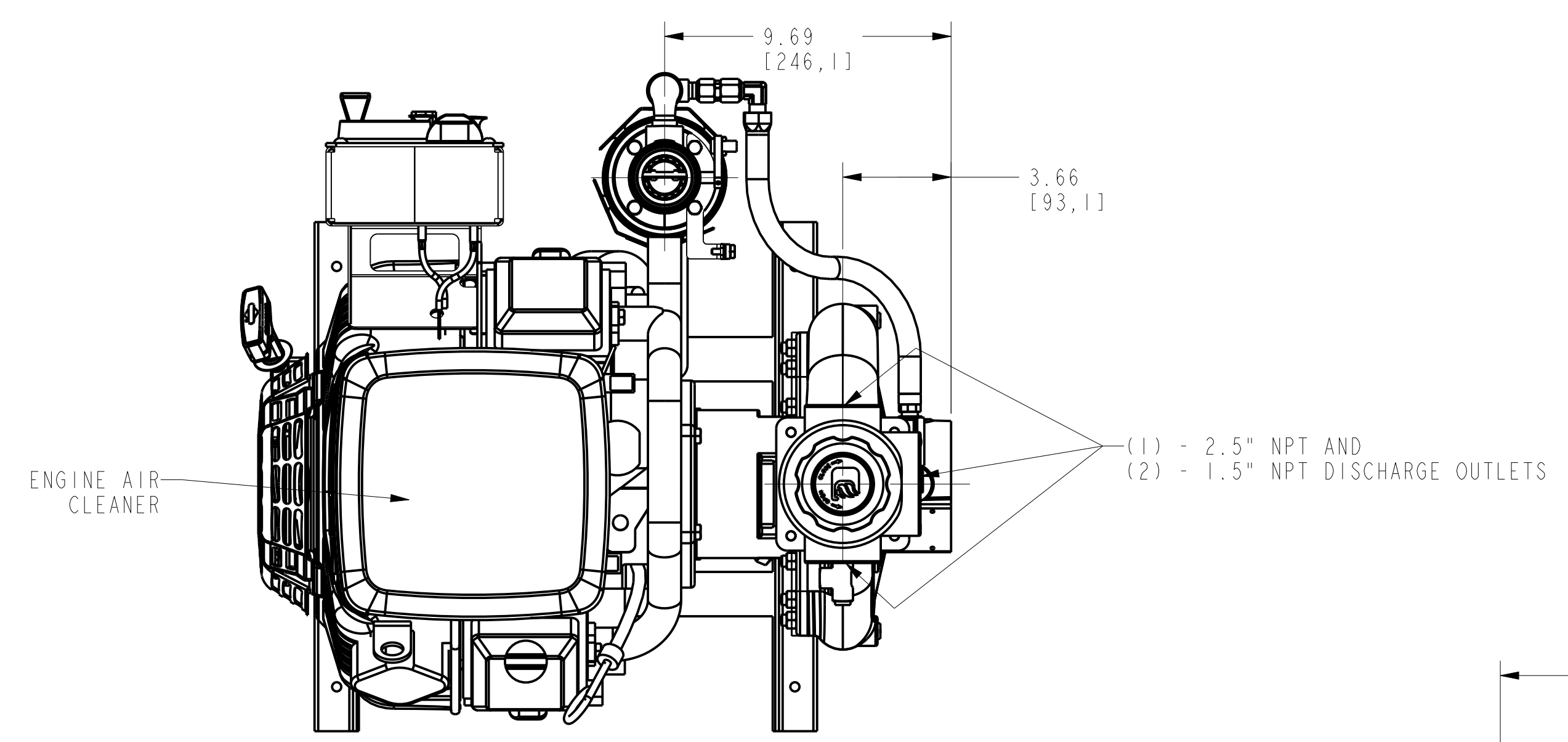

APPROXIMATE WEIGHT: 152 LBS (69 KG)

REMOVE SHARP EDGES		INCH (MILLIMETER)		TOLERANCE EXCEPT AS NOTED 0.00 ± 0.03 0.000 ± 0.010 ANGLES ± 1°		 W.S. Darley & Co. ITASCA, IL - CHIPPEWA FALLS, WI	
MATERIAL DESCRIPTION:		MATERIAL NO.	PATTERN NO.	DR'N: TED	DATE 07-JUN-14	DWG - 2BE18V, SKID NO FUEL TANK, W/CONTROLS	
THIS DESIGN IS THE PROPERTY OF W.S. DARLEY AND CO. - UNAUTHORIZED REPRODUCTION IS PROHIBITED.		ALL DIMENSIONS IN INCHES UNLESS NOTED		CHWD: AAN	SCALE 1/4	DBD0213	

MODEL NAME: DBD0213
MOL CREATED: 6 JAN 2014
SHEET: 1/1