

REVISIONS				
LTR	DESCRIPTION	DATE	CHG NO.	APPRD

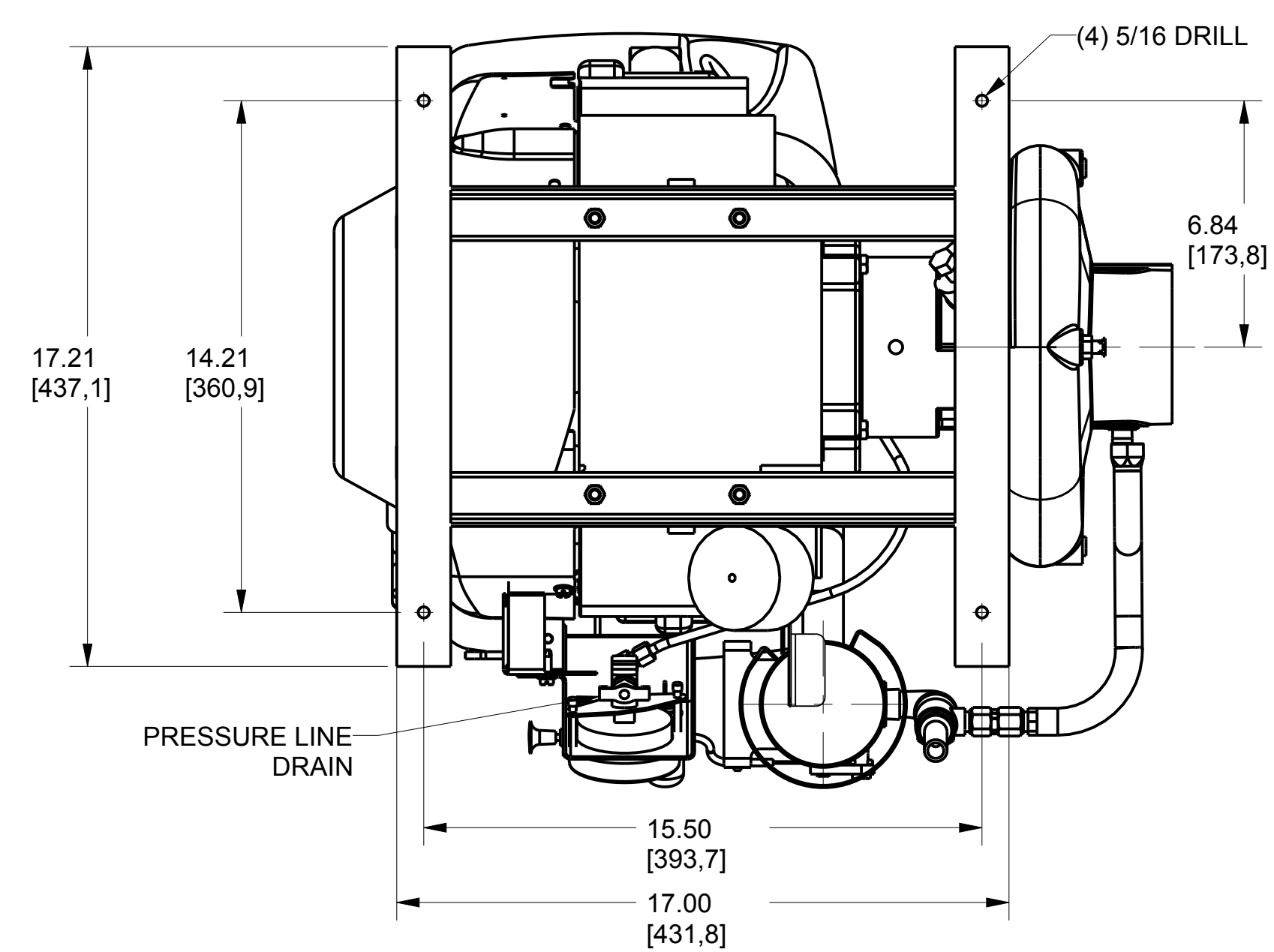
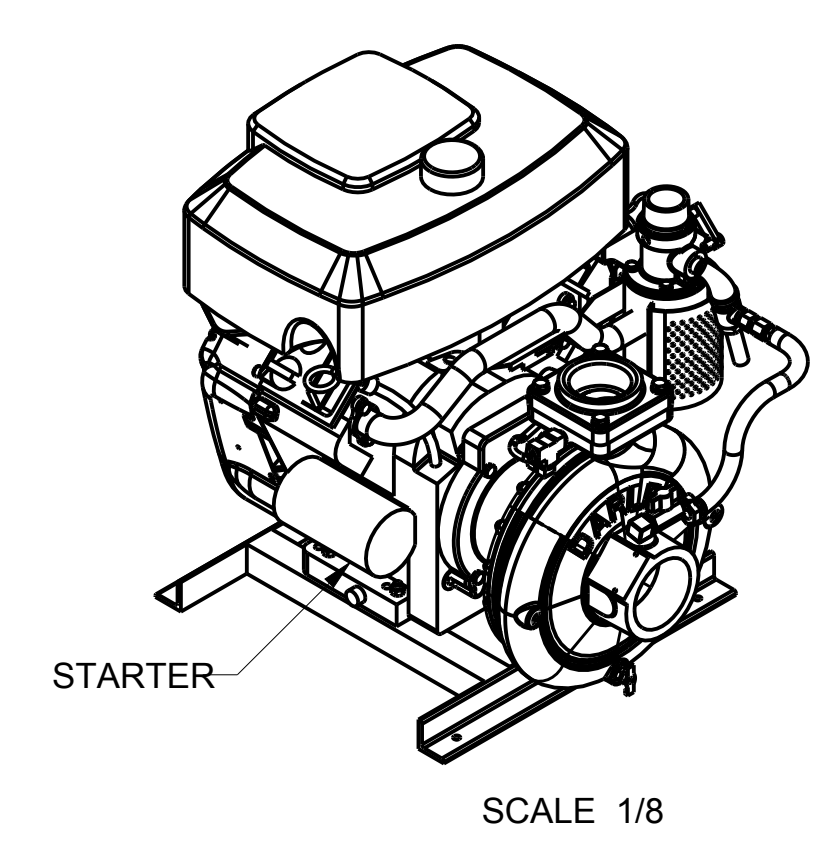
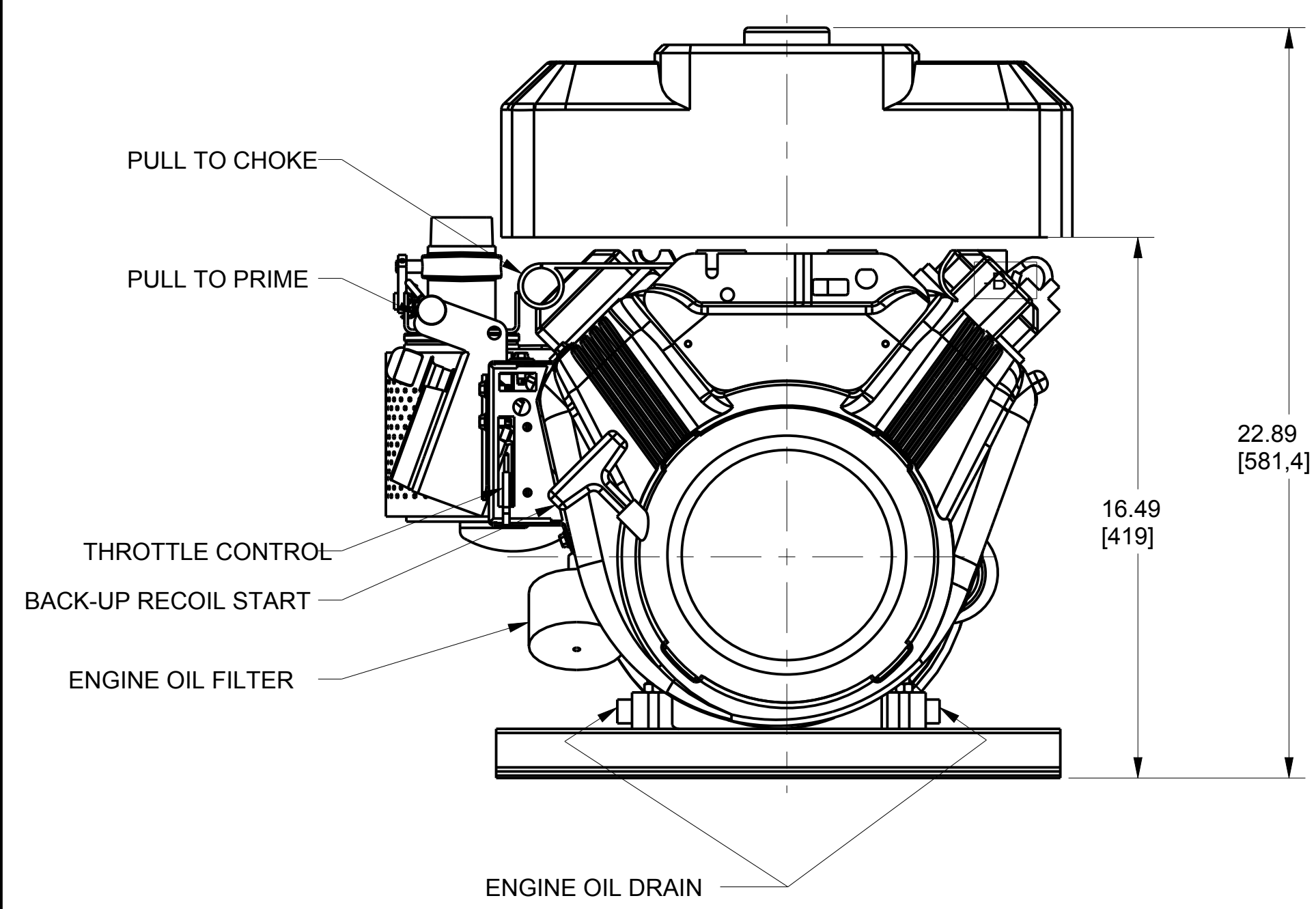
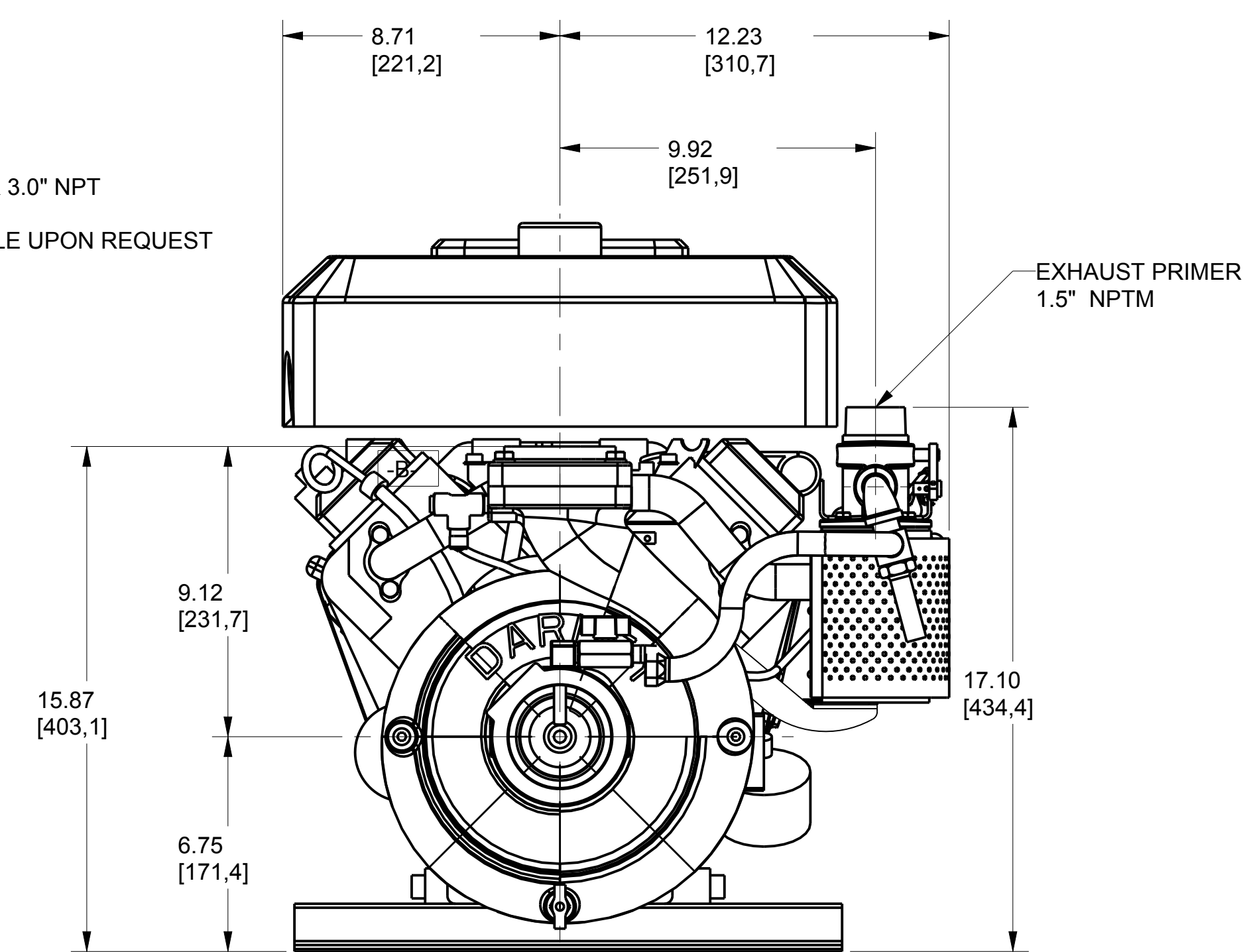
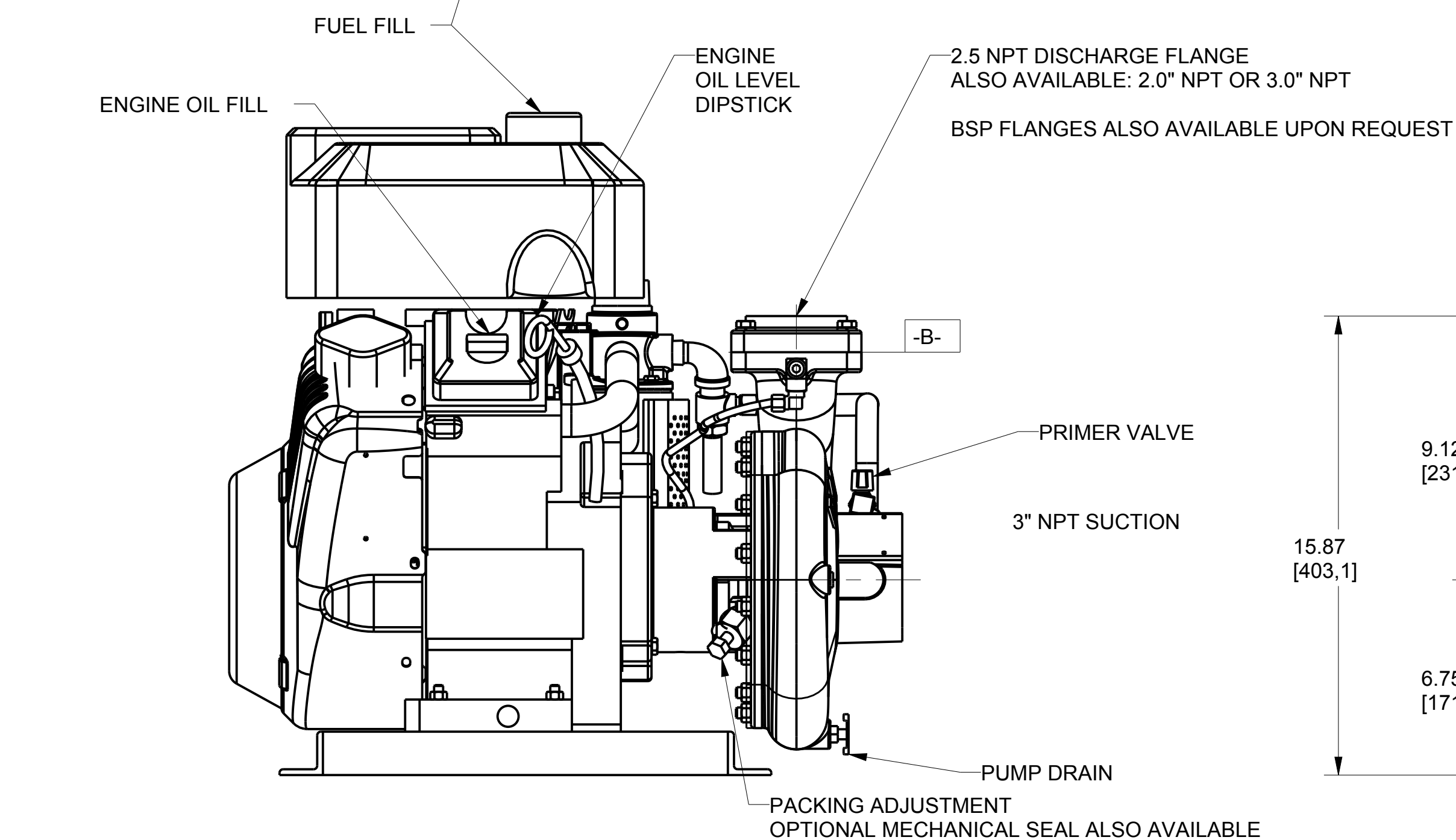
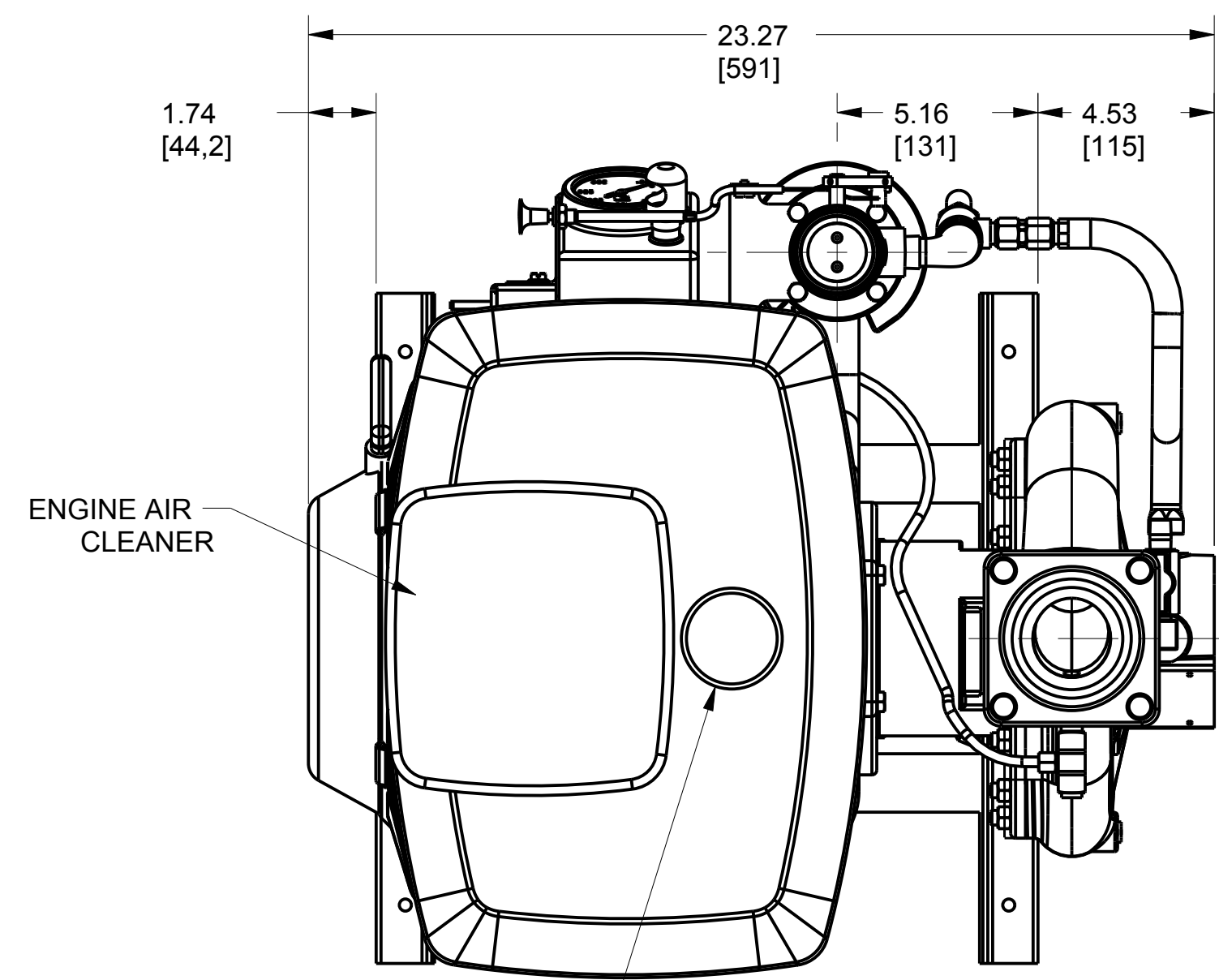
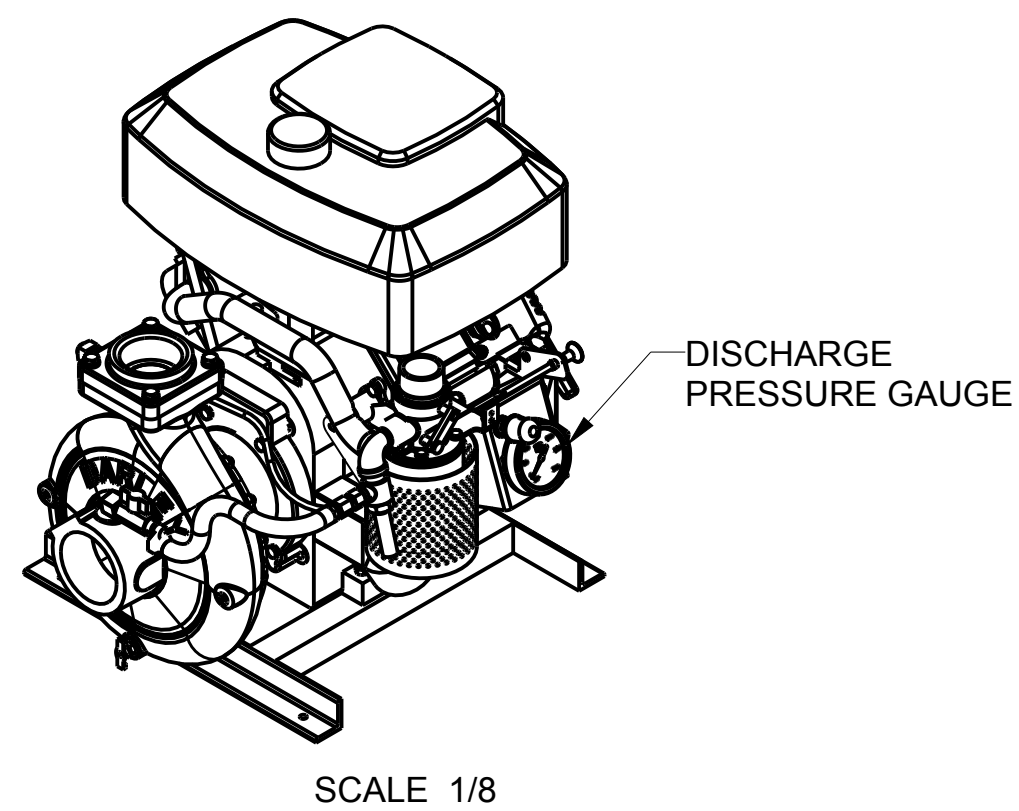

APPROXIMATE WEIGHT: 145 LBS  
(66 KG)

REMOVE SHARP EDGES		INCH [MILLIMETER]	OLD PART NO.	TOLERANCE EXCEPT AS NOTED	W.S. Darley & Co. ITASCA, IL - CHIPPEWA FALLS, WI
MATERIAL DESCRIPTION:	MATERIAL NO.	PATTERN NO.	00 ±.03 2000 ±.010 ANGLES ±.1°	2BE 18HP COOLER/CLEANER VANGUARD W/TANK - DIMENSIONAL	DATE 24-May-07
THIS DESIGN IS THE PROPERTY OF W.S. DARLEY AND CO. - UNAUTHORIZED REPRODUCTION IS PROHIBITED		ALL DIMENSIONS IN INCHES UNLESS NOTED	DO NOT SCALE PRINT	DRY AAN CHKD TED TRCD	SCALE 1/8
				DBD0205	1/1 D
				DBD0205	1/1 D