

REVISIONS				
LTR	DESCRIPTION	DATE	CHG NO.	APPRD

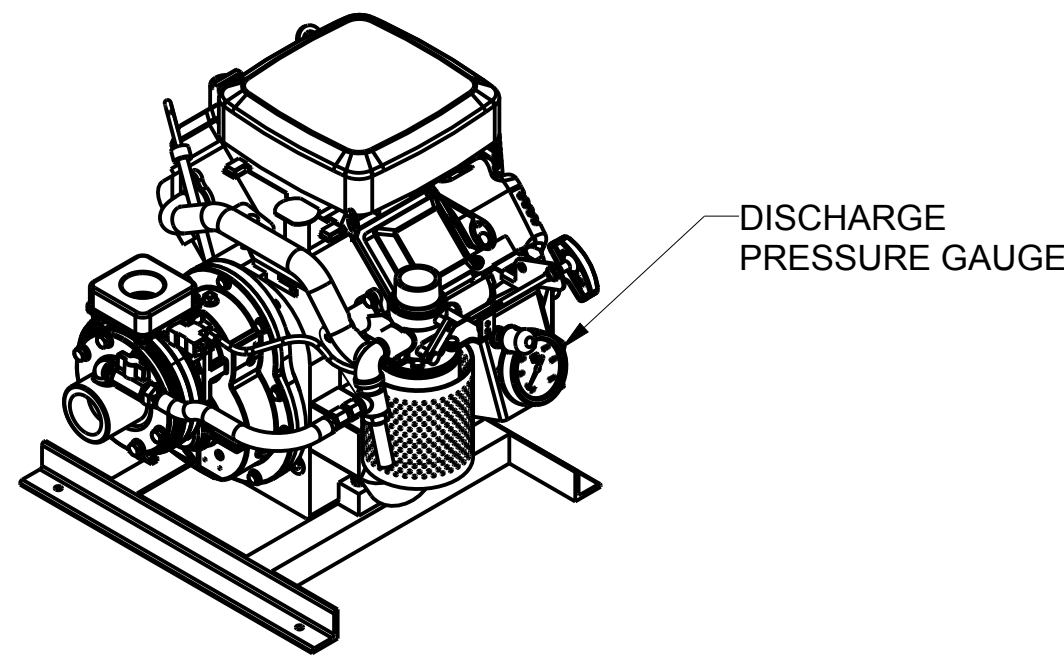

DISCHARGE PRESSURE GAUGE

SCALE 1/8

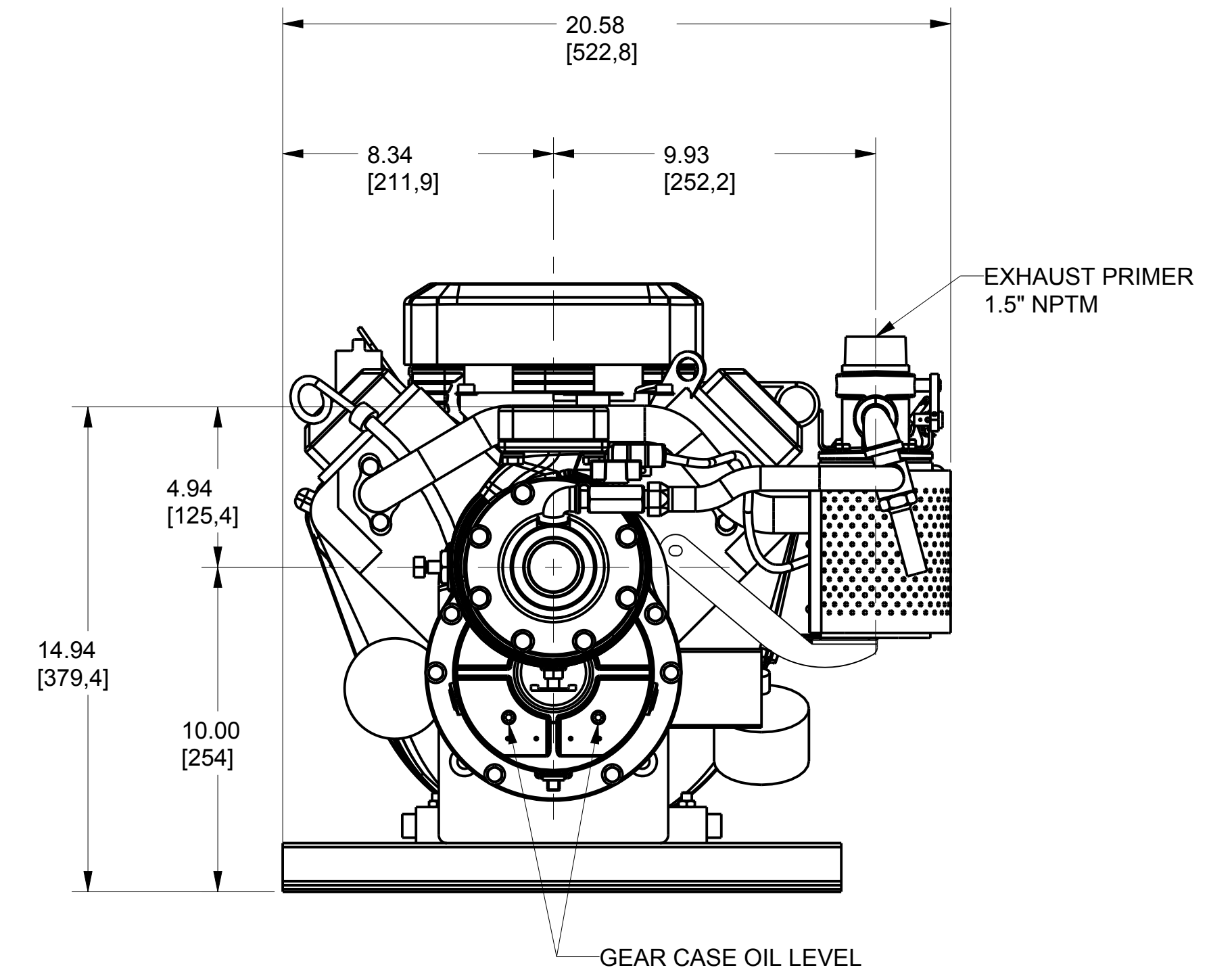
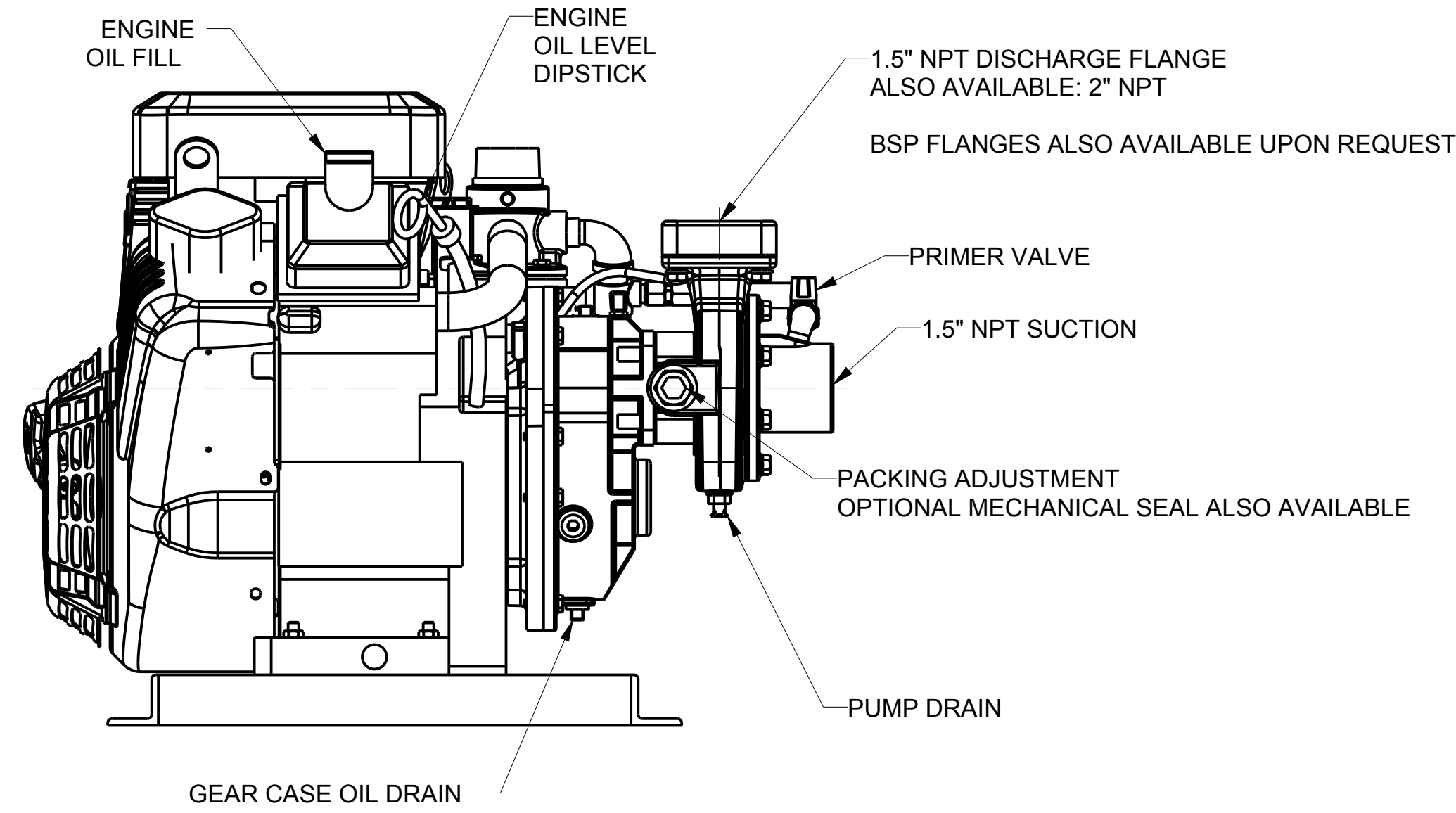
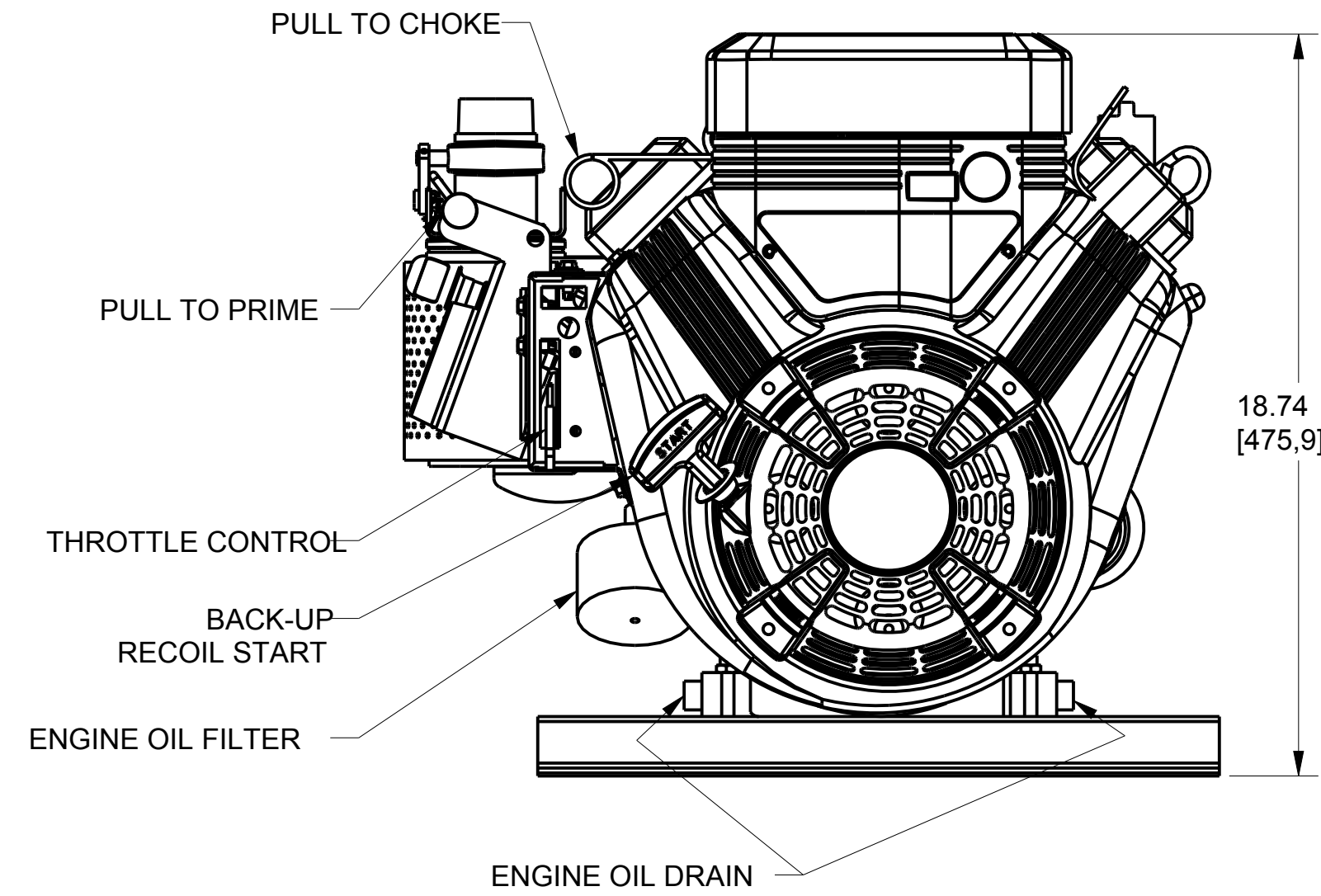
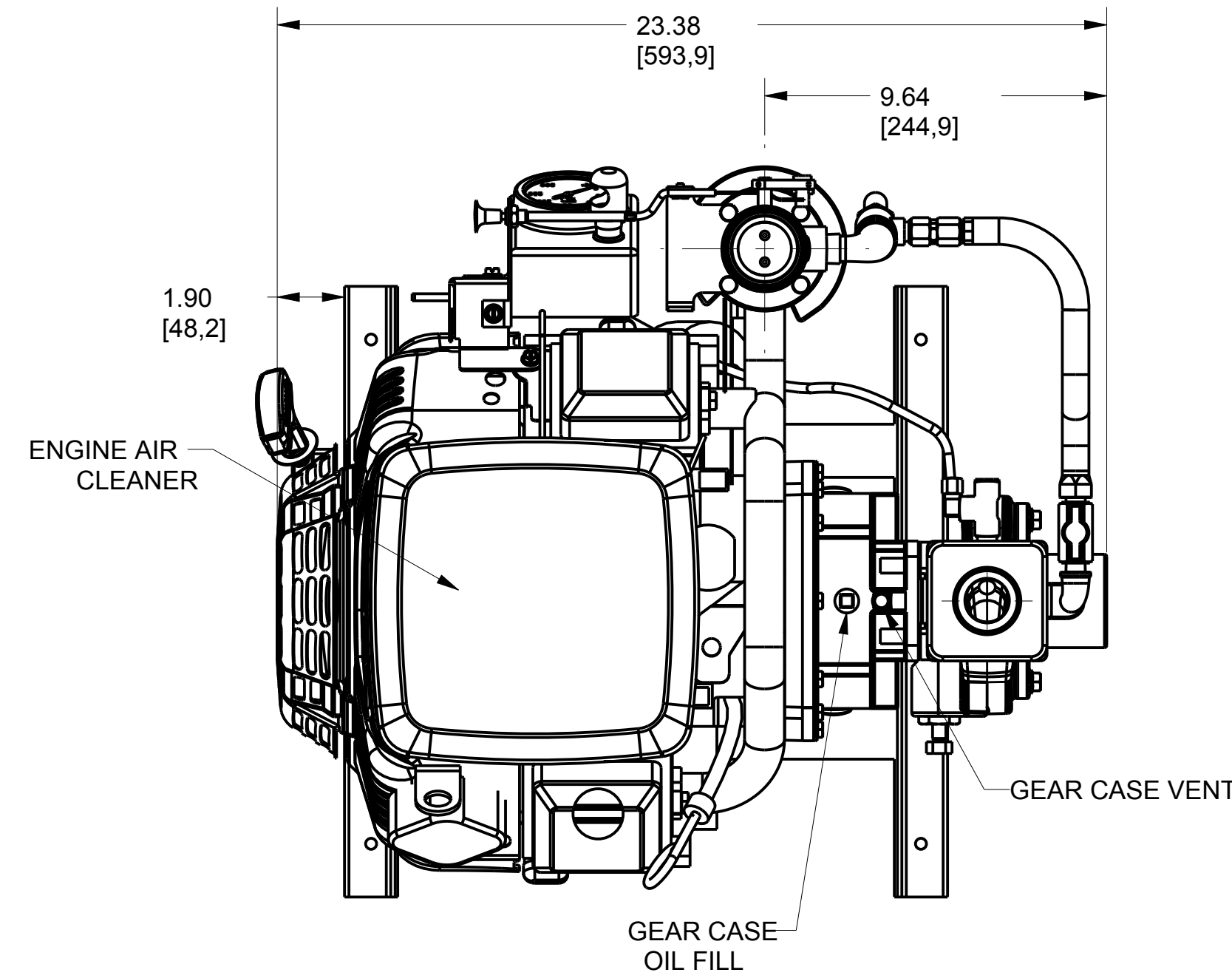

APPROXIMATE WEIGHT: 145 LBS
(66KG)

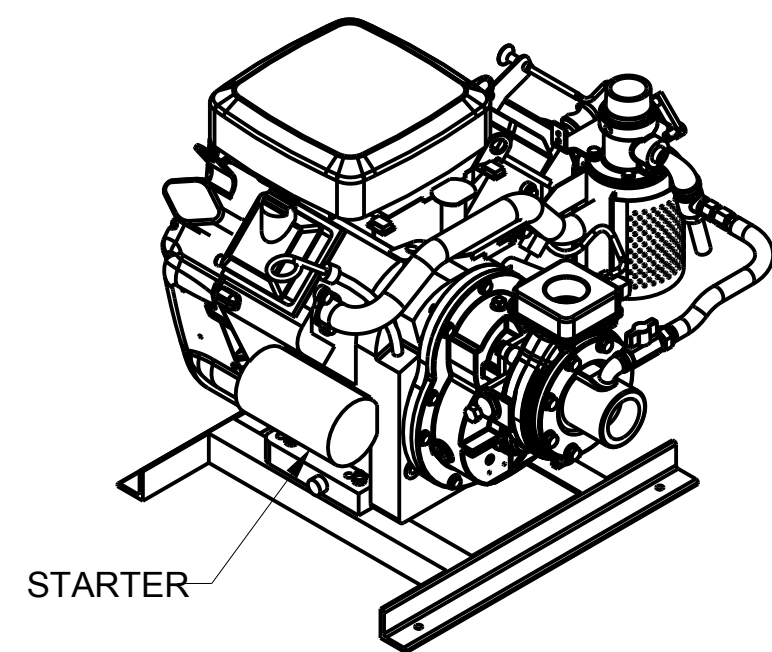

STARTER

SCALE 1/8

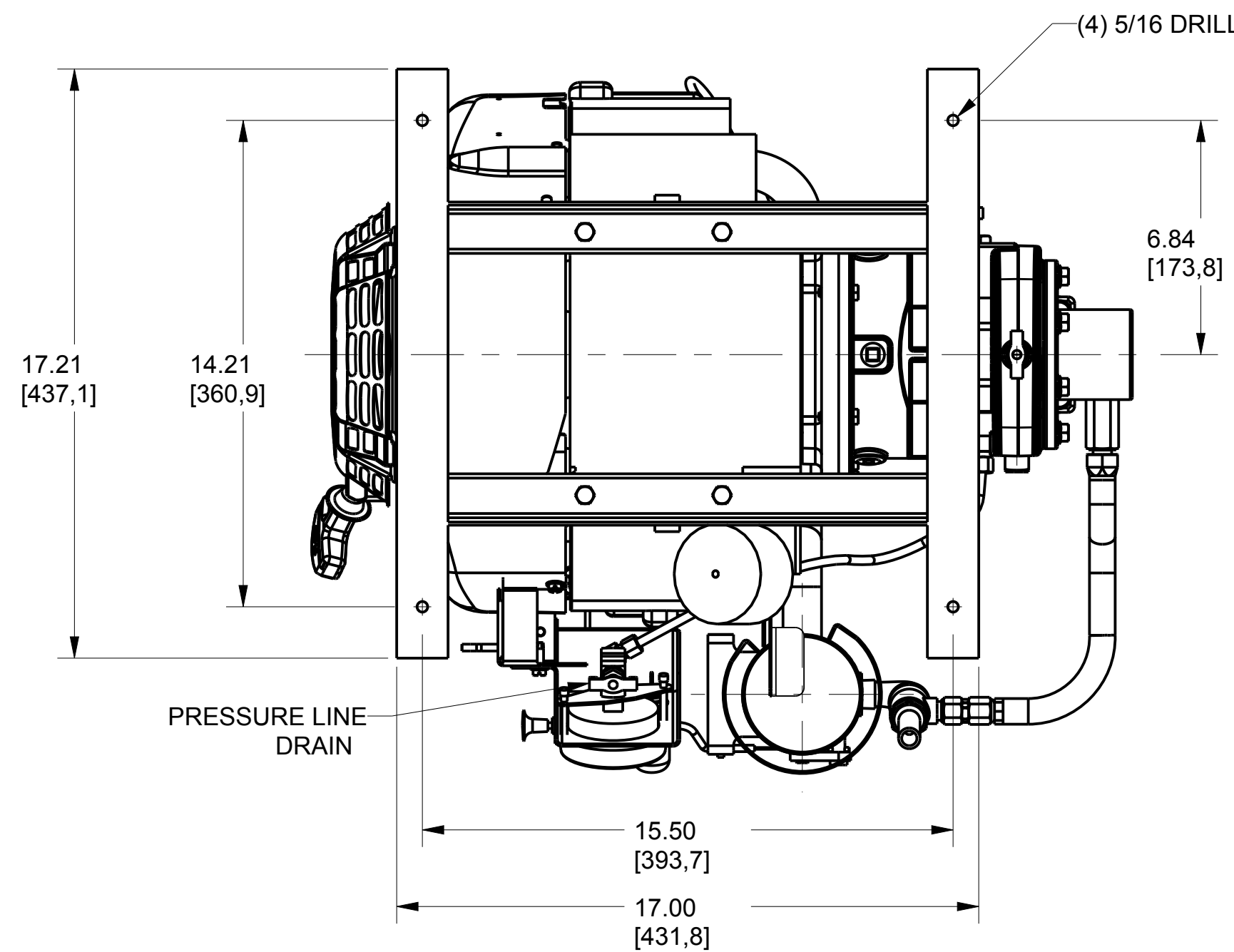

REMOVE SHARP EDGES		INCH [MILLIMETER]		TOLERANCE EXCEPT AS NOTED		OLD PART NO.		W.S. Darley & Co. ITASCA, IL - CHIPPEWA FALLS, WI	
MATERIAL DESCRIPTION:		MATERIAL NO.		PATTERN NO.		1.25 AGE 18 HP COOLER/CLEANER VANGUARD - DIMENSIONAL		DATE 29-May-07	
THIS DESIGN IS THE PROPERTY OF W.S. DARLEY AND CO. - UNAUTHORIZED REPRODUCTION IS PROHIBITED		ALL DIMENSIONS IN INCHES UNLESS NOTED		DO NOT SCALE PRINT		DRN: JWG/AN		SCALE 1/4	
		CHKD: TED		TRCD		DAD1505		SHEET 1/1	