

REVISIONS				
LTR	DESCRIPTION	DATE	CHG NO.	APPRD

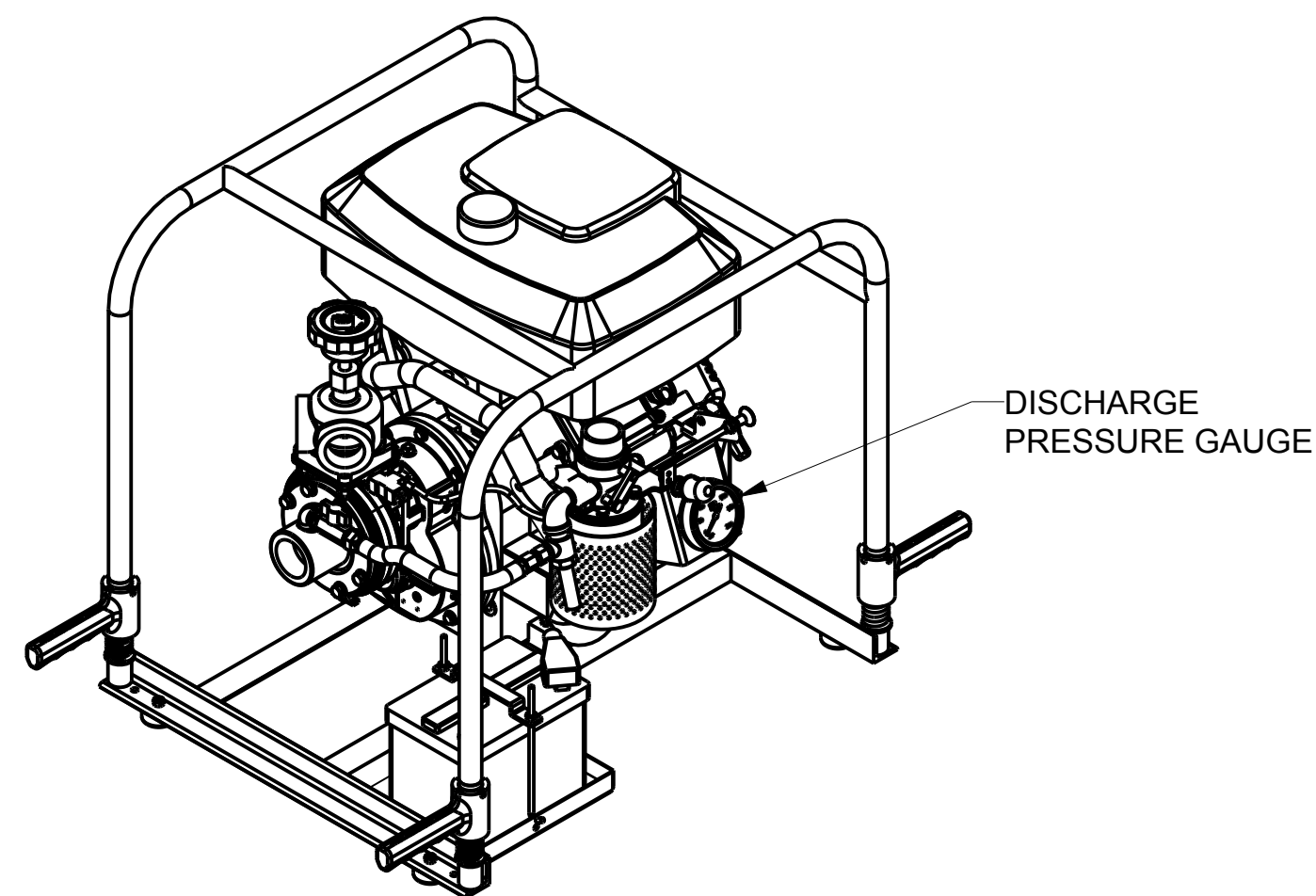

SCALE 1/8

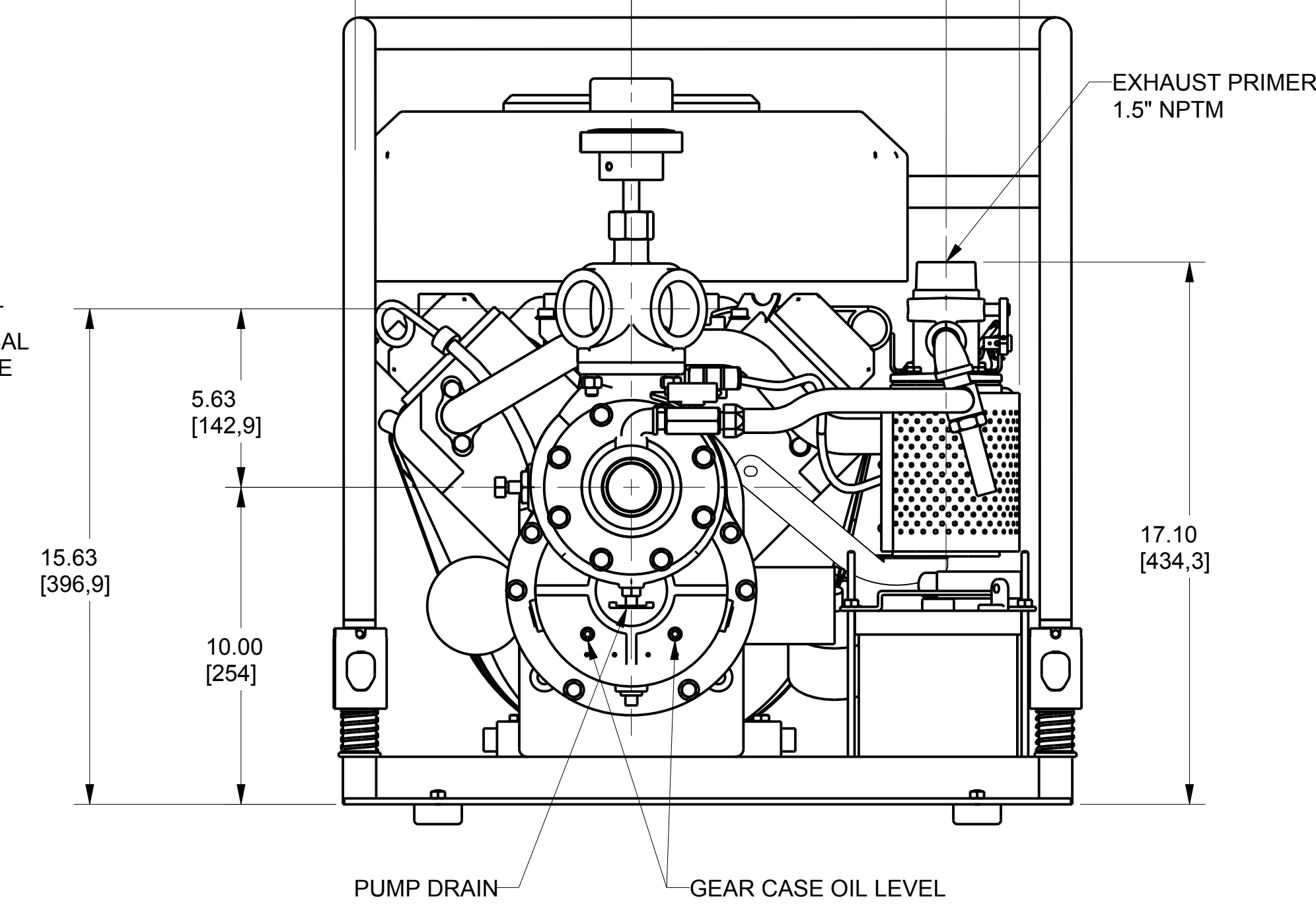
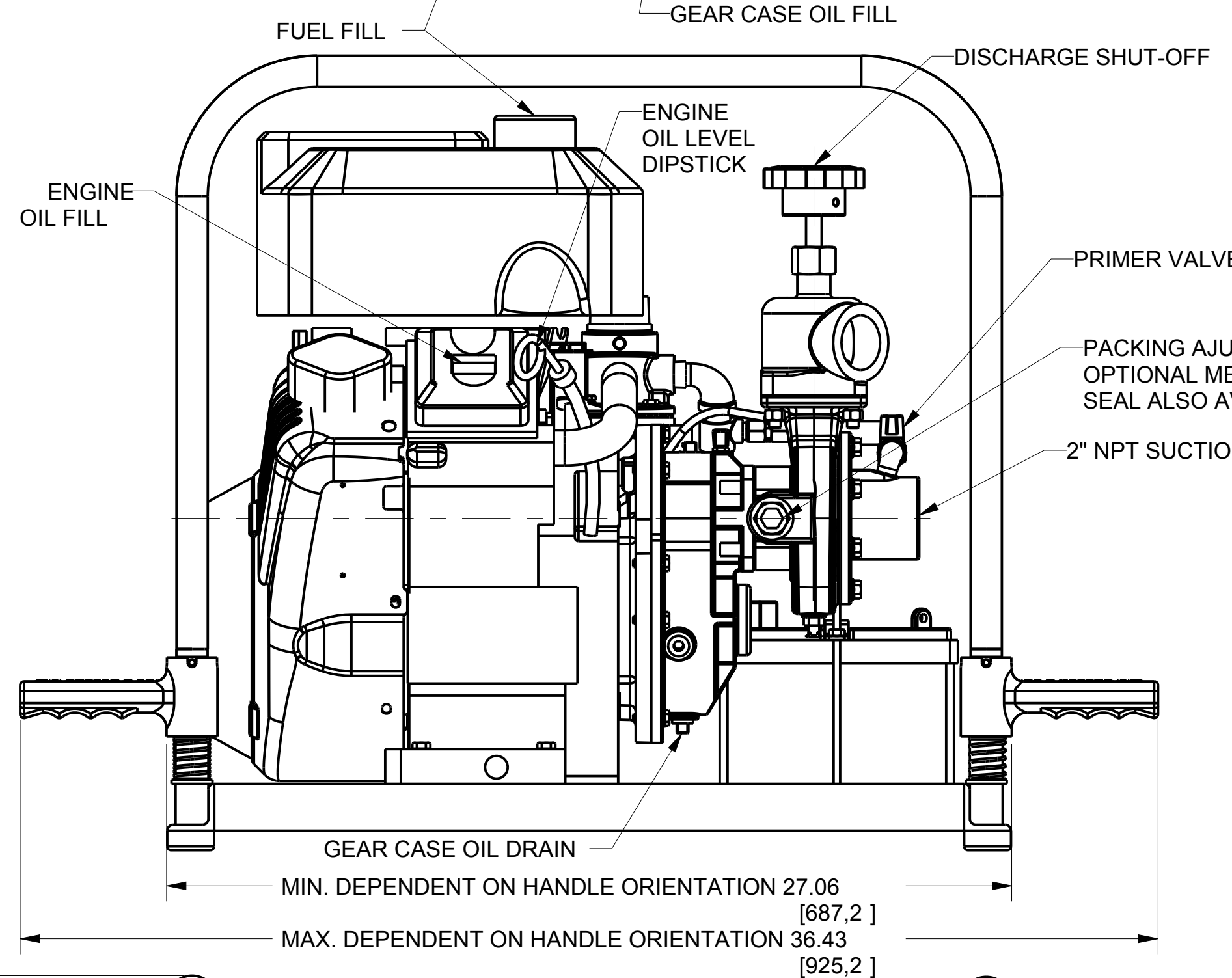
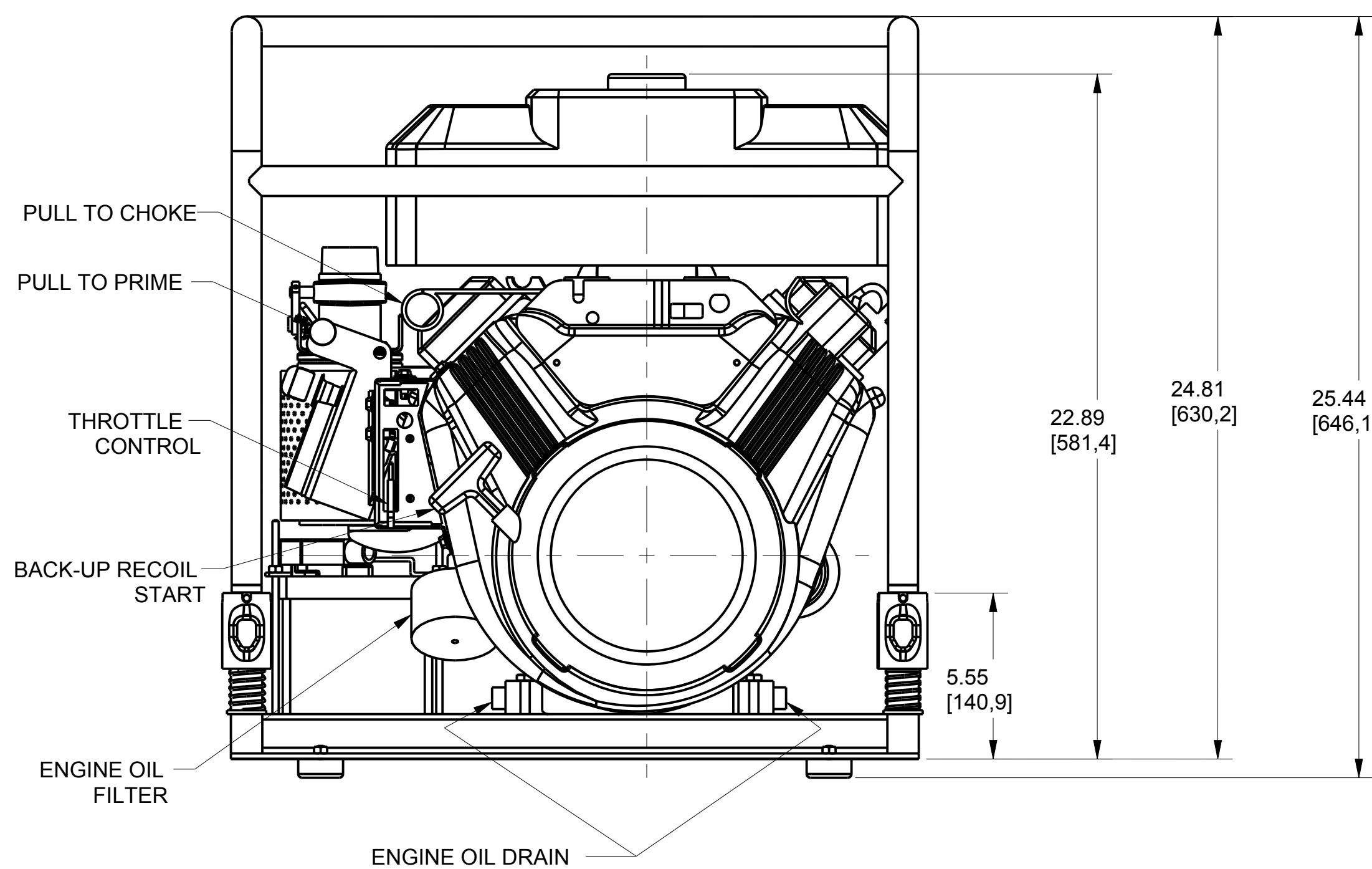
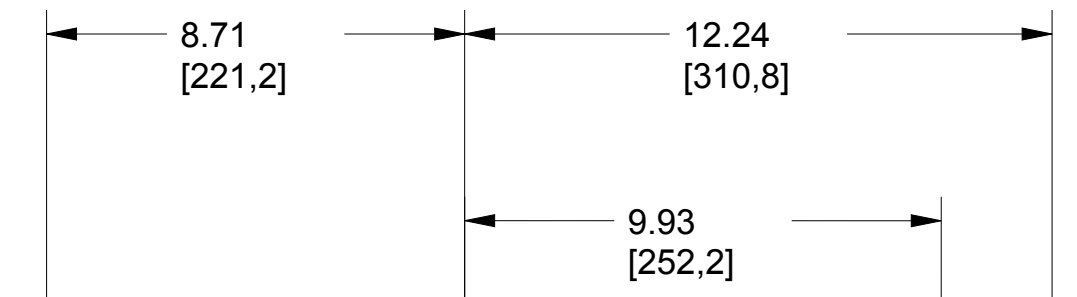
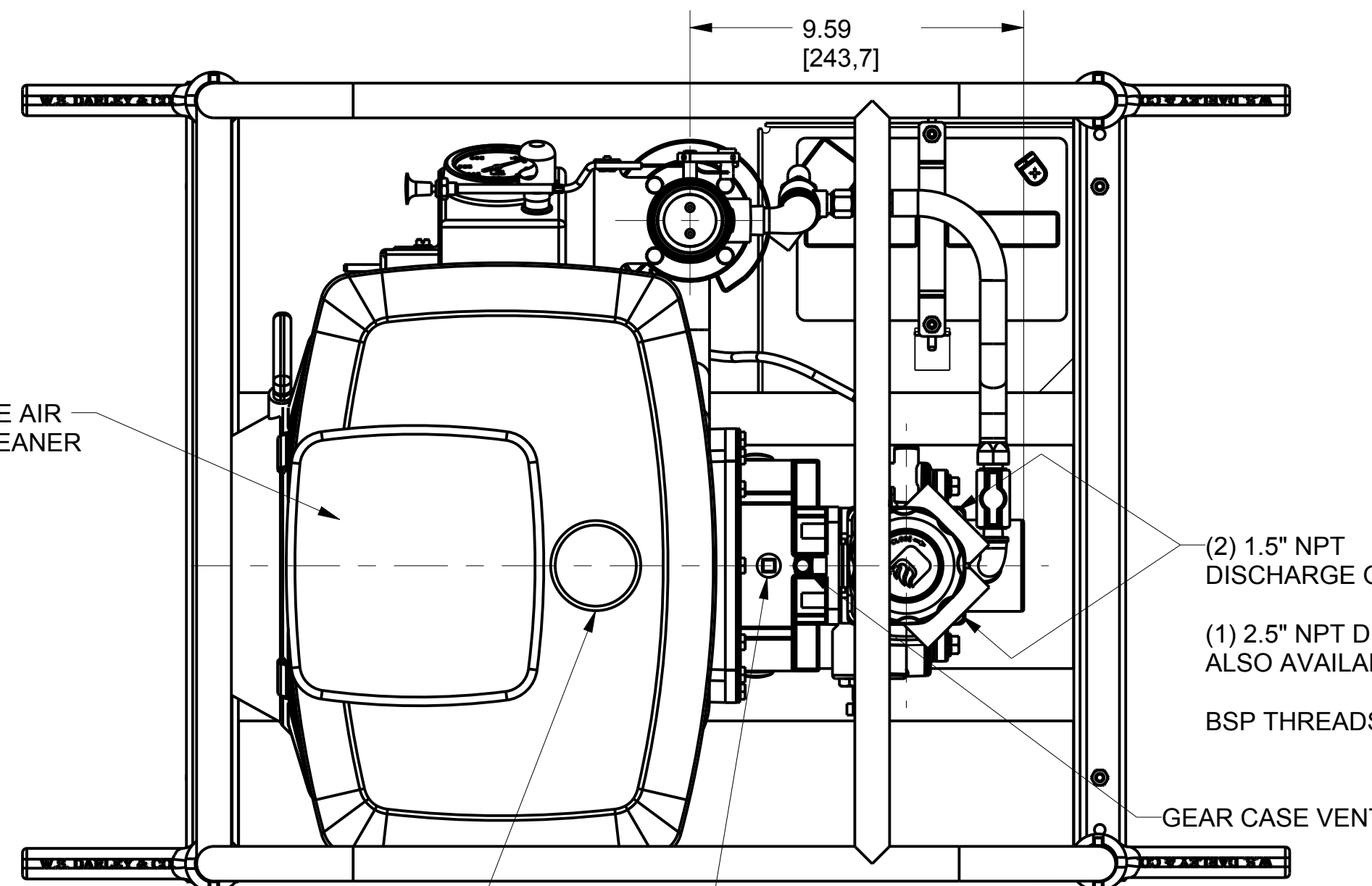

APPROXIMATE WEIGHT: 157 LBS (72KG)

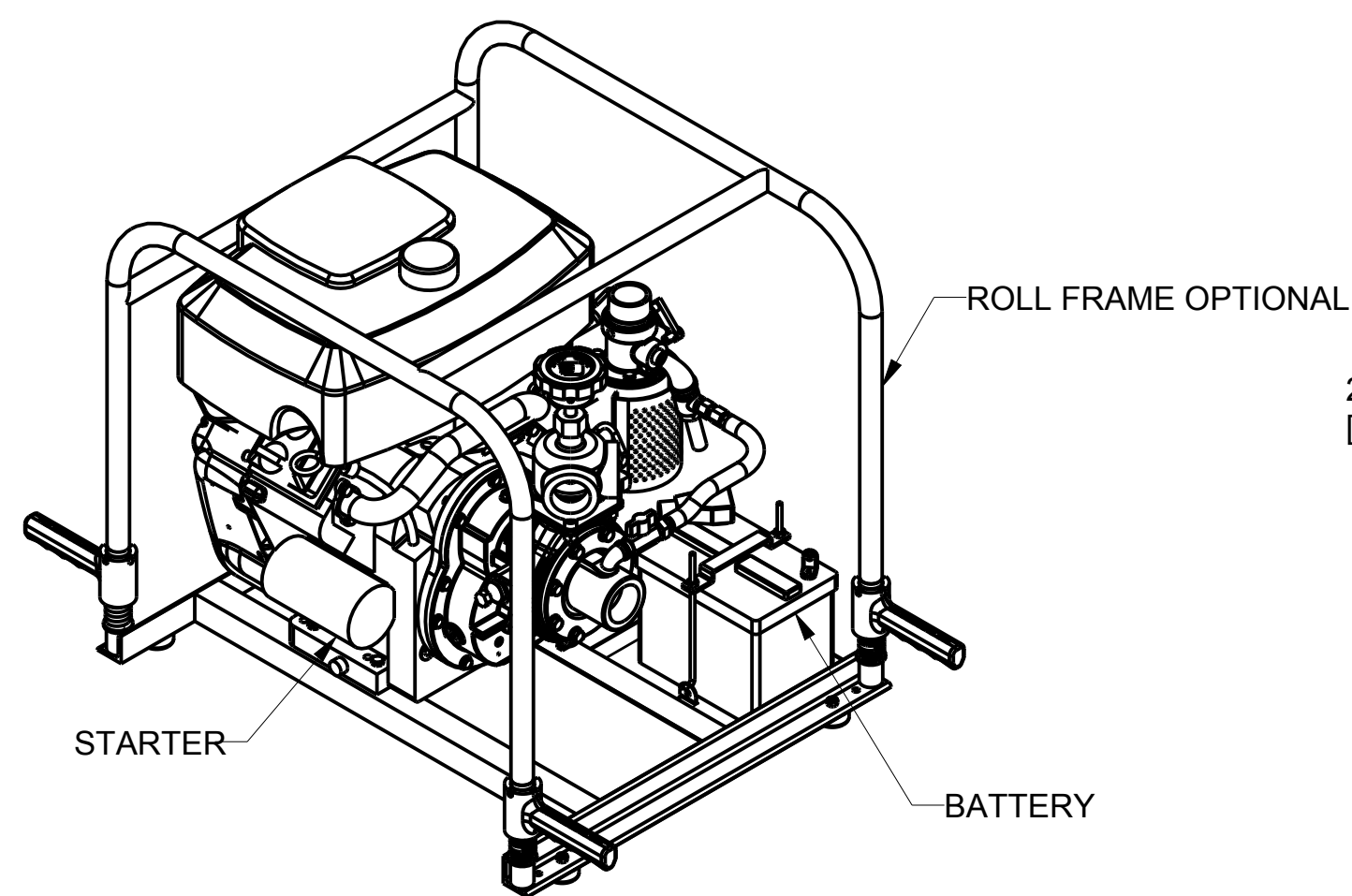

SCALE 1/8

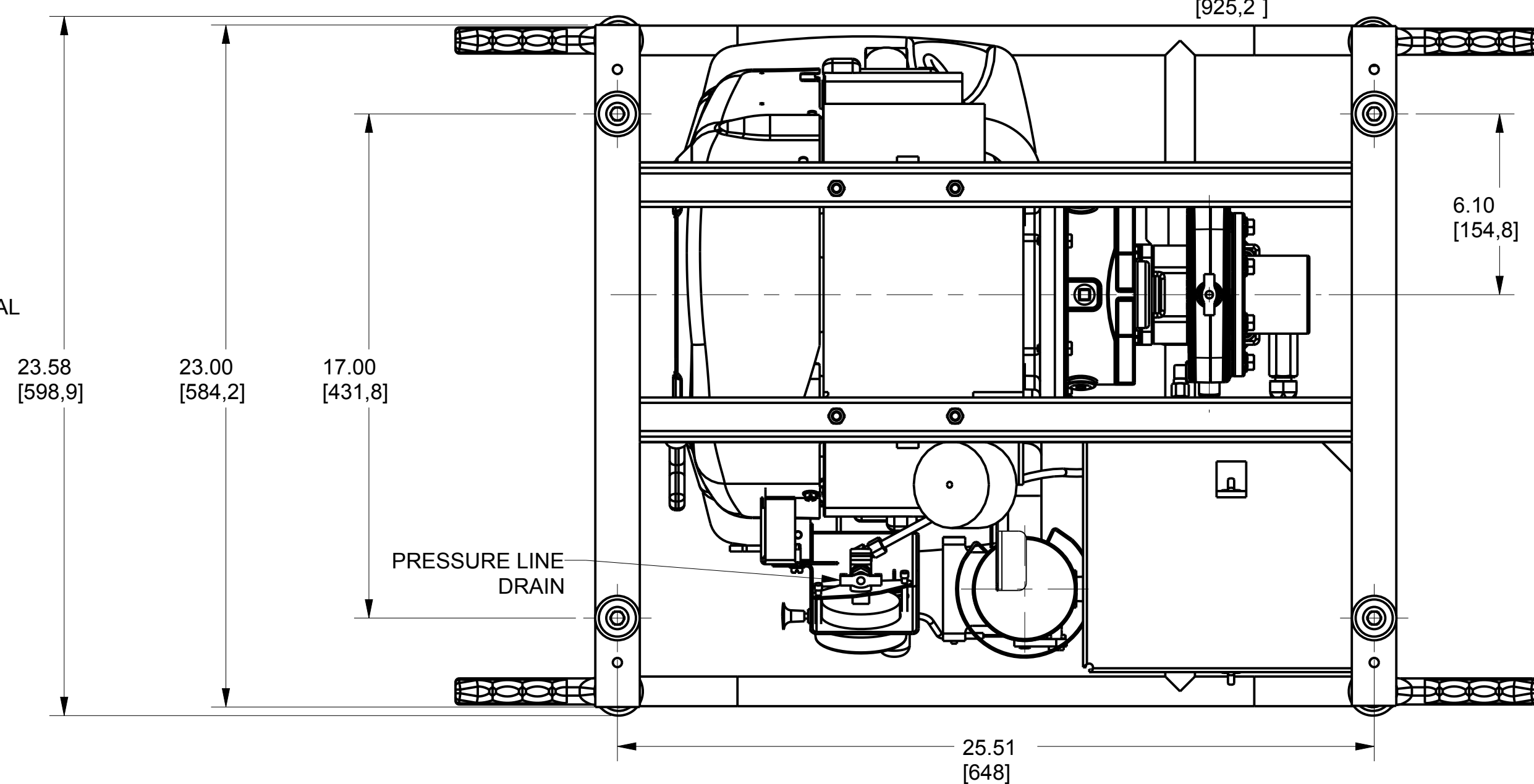

REMOVE SHARP EDGES		INCH [MILLIMETER]	OLD PART NO.	TOLERANCE EXCEPT AS NOTED	W.S. Darley & Co. ITASCA, IL - CHIPPEWA FALLS, WI
MATERIAL DESCRIPTION:	MATERIAL NO.	PATTERN NO.	00 ±.03 2000 ±.010 ANGLES ±1°	1.25 AGE 18 HP PORTABLE VANGUARD W/ ROLL FRAME AND TANK - DIM	DATE 25-May-07
THIS DESIGN IS THE PROPERTY OF W.S. DARLEY AND CO. - UNAUTHORIZED REPRODUCTION IS PROHIBITED		ALL DIMENSIONS IN INCHES UNLESS NOTED	DO NOT SCALE PRINT	DRN JWG/AN CHKD TED TRCD	SCALE 1/4

DAD1504