

REVISIONS				
LTR	DESCRIPTION	DATE	CHG NO.	APPRD

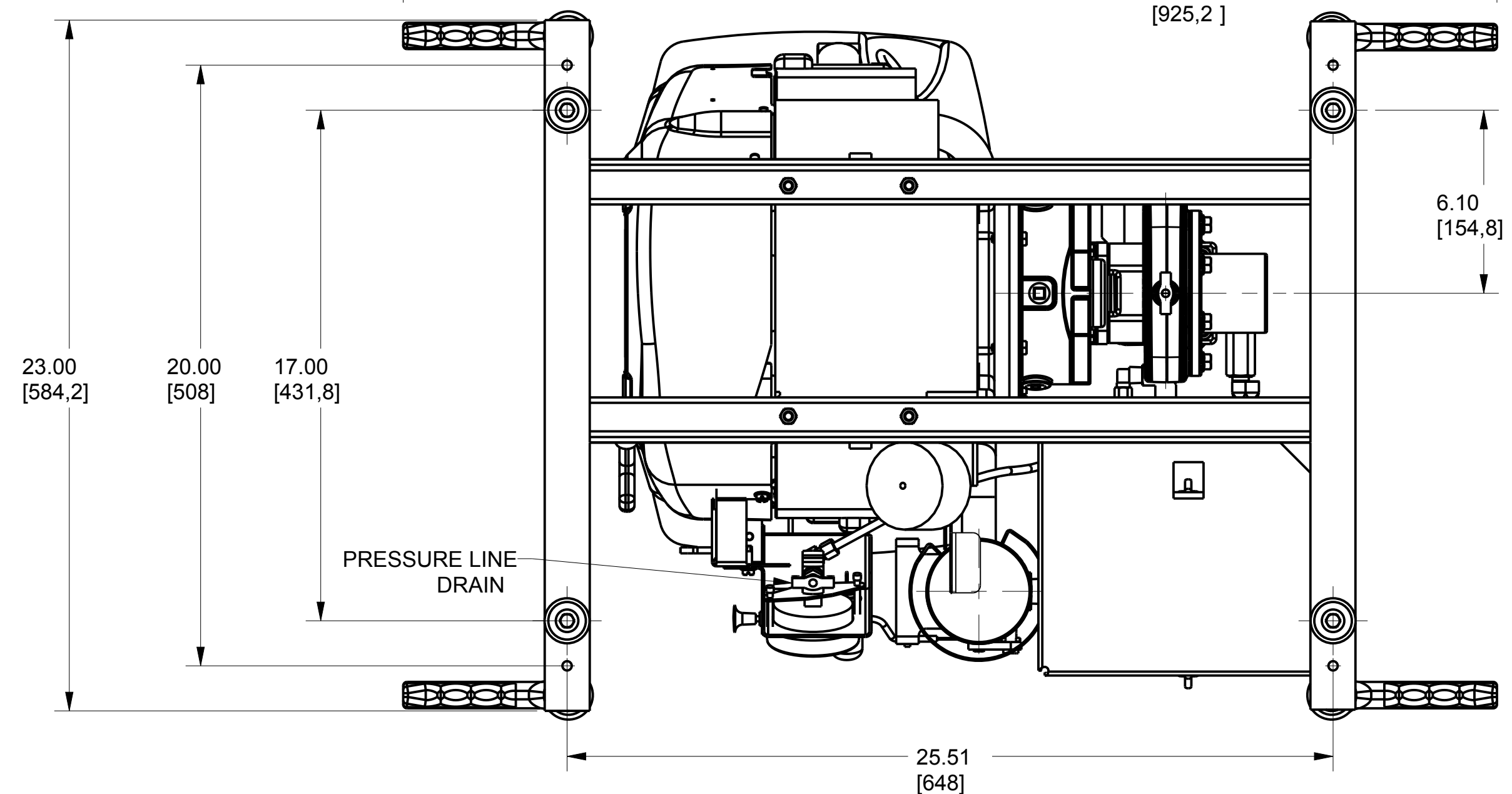
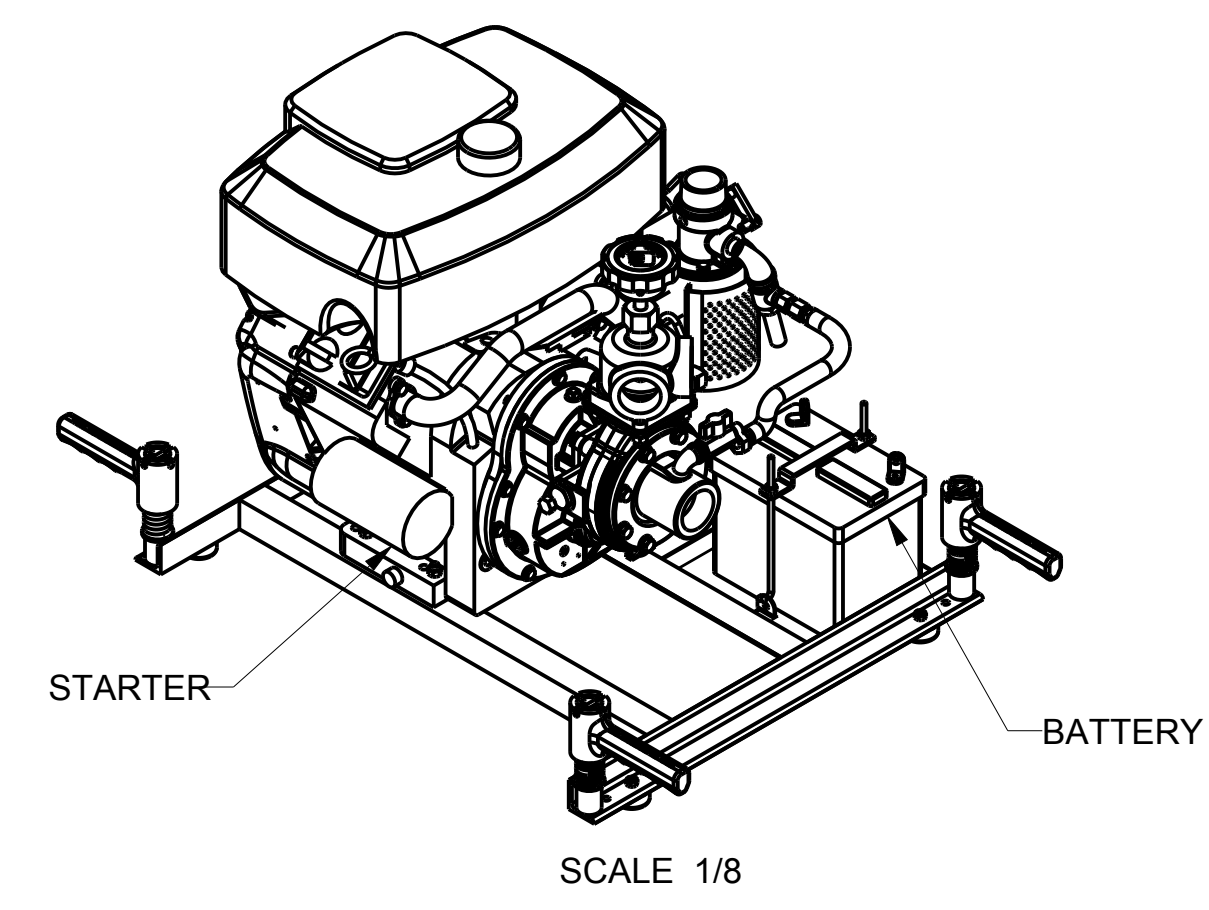
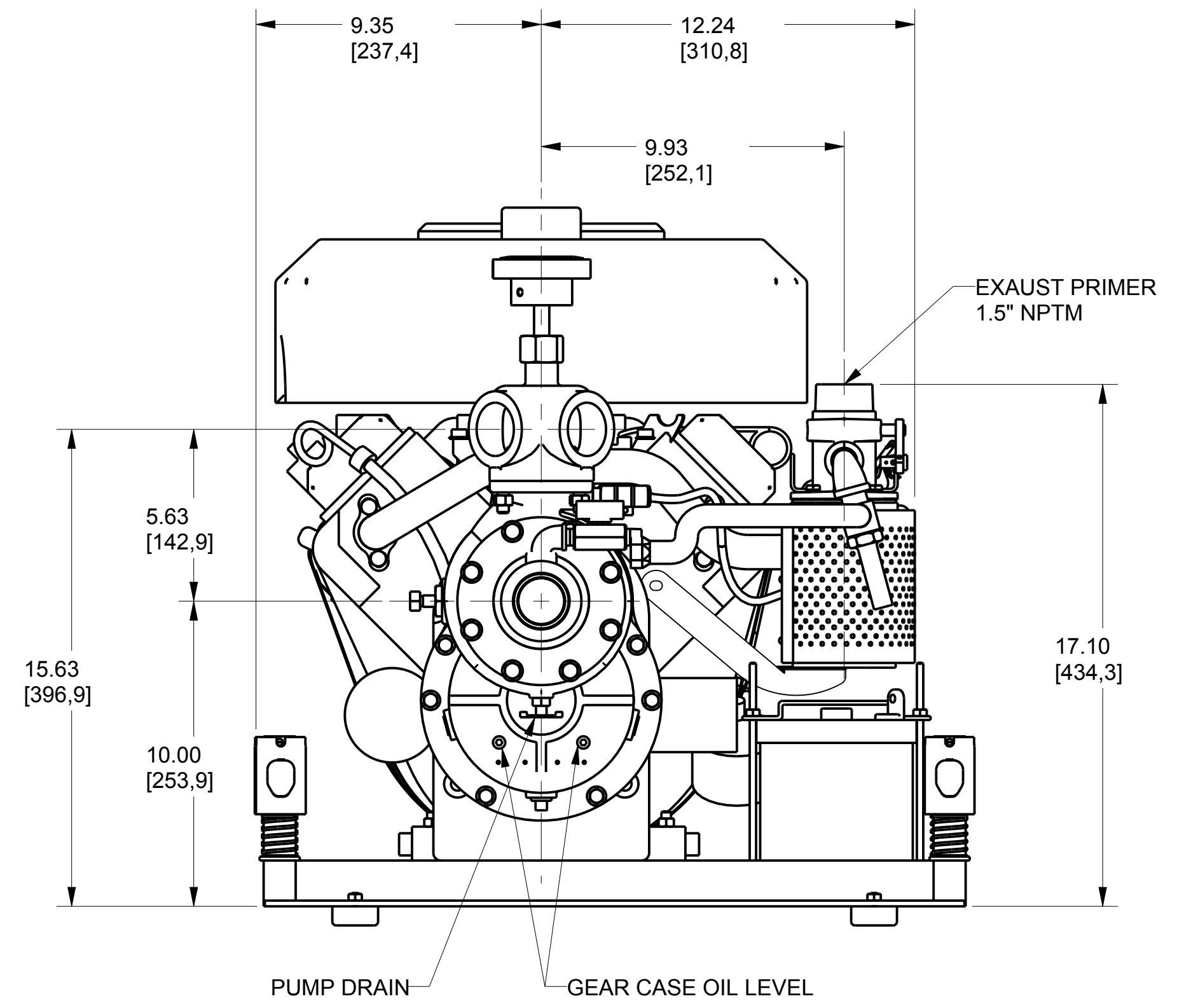
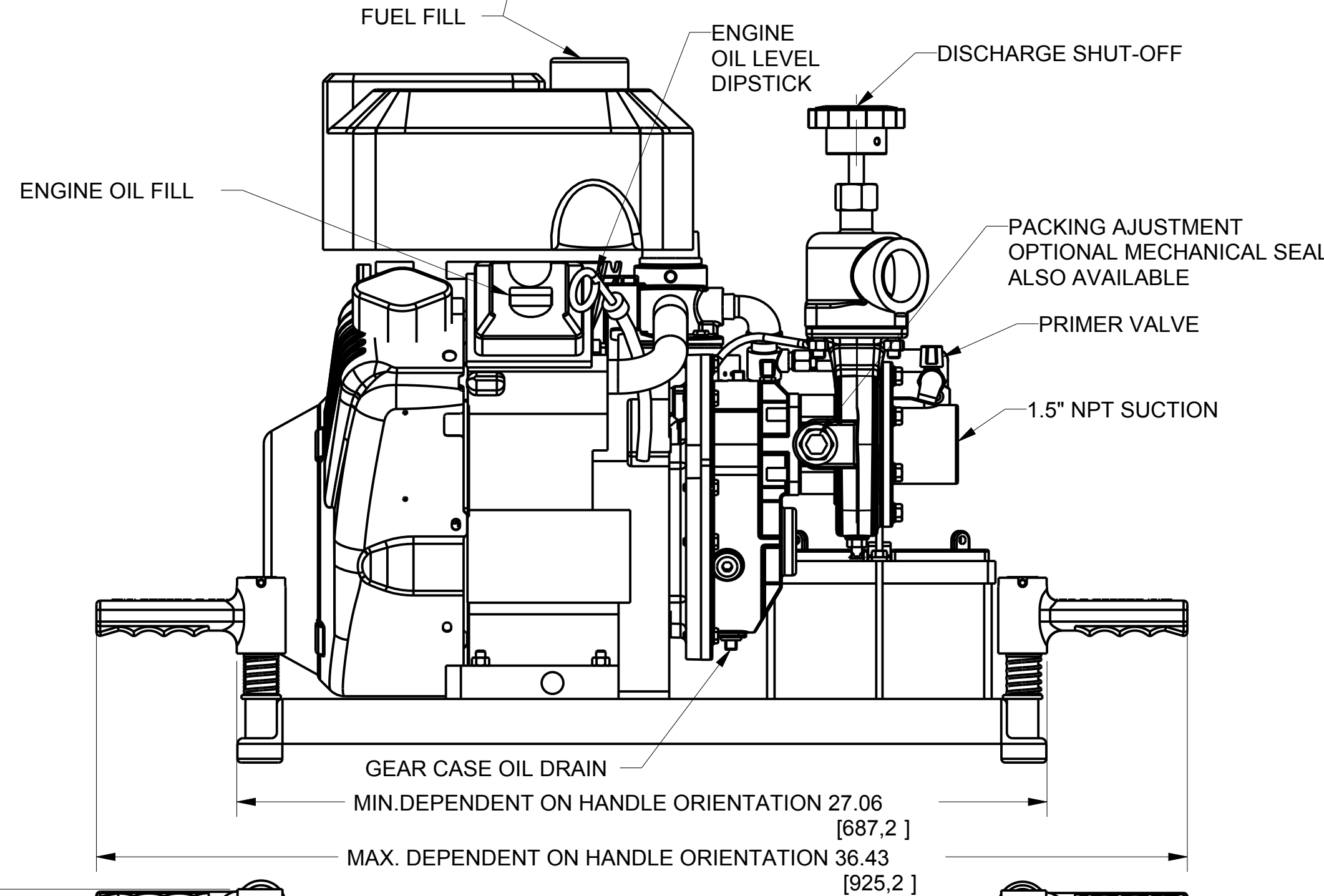
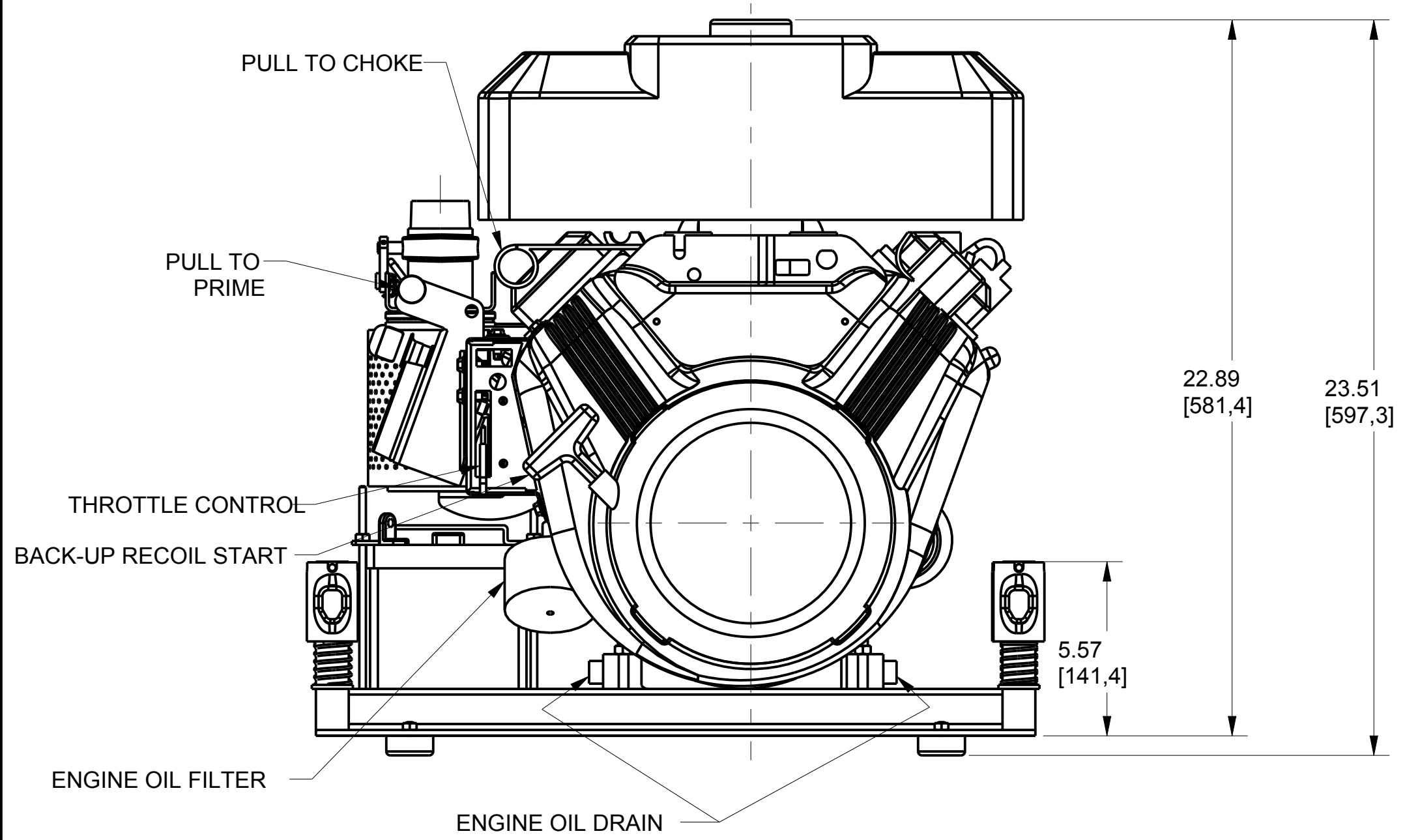
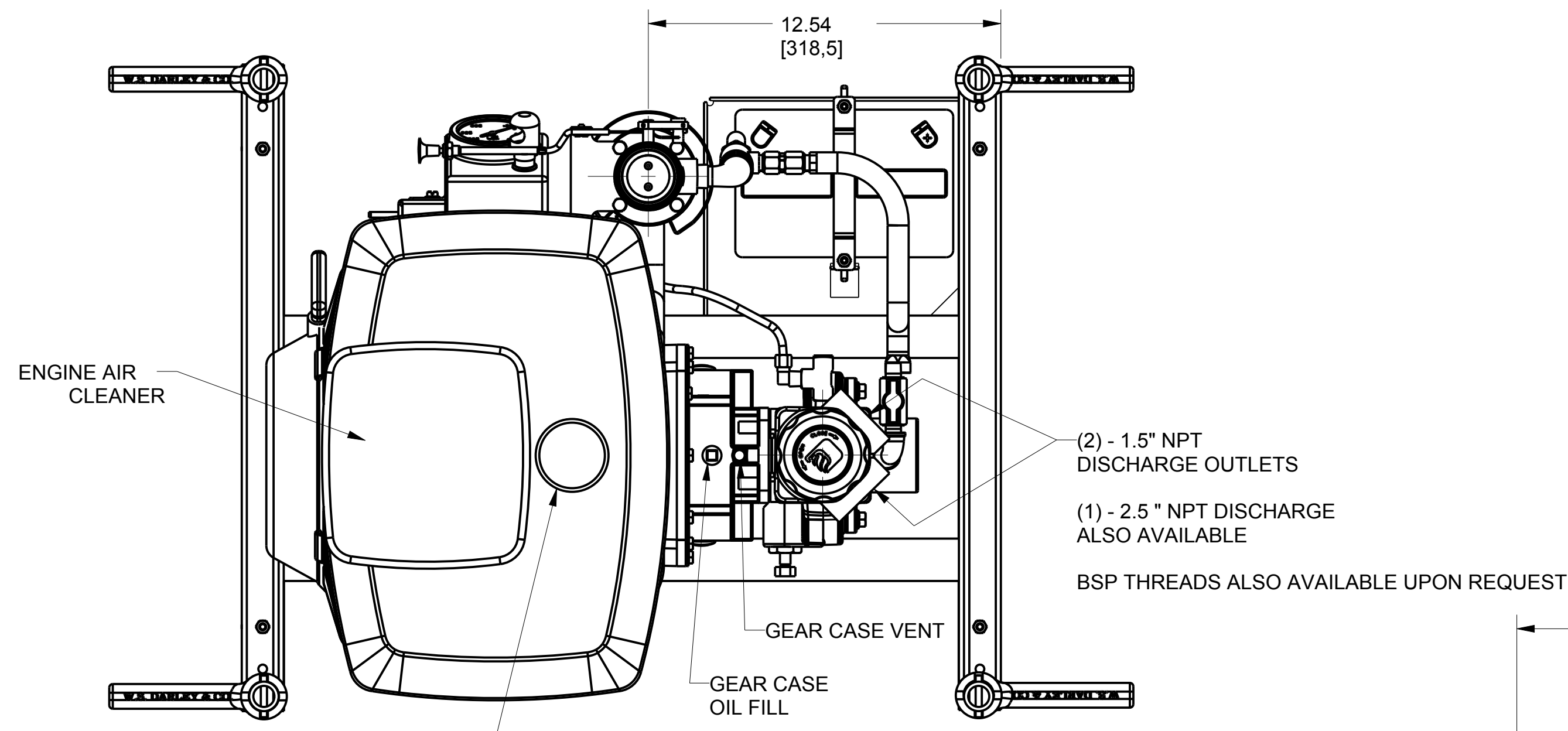
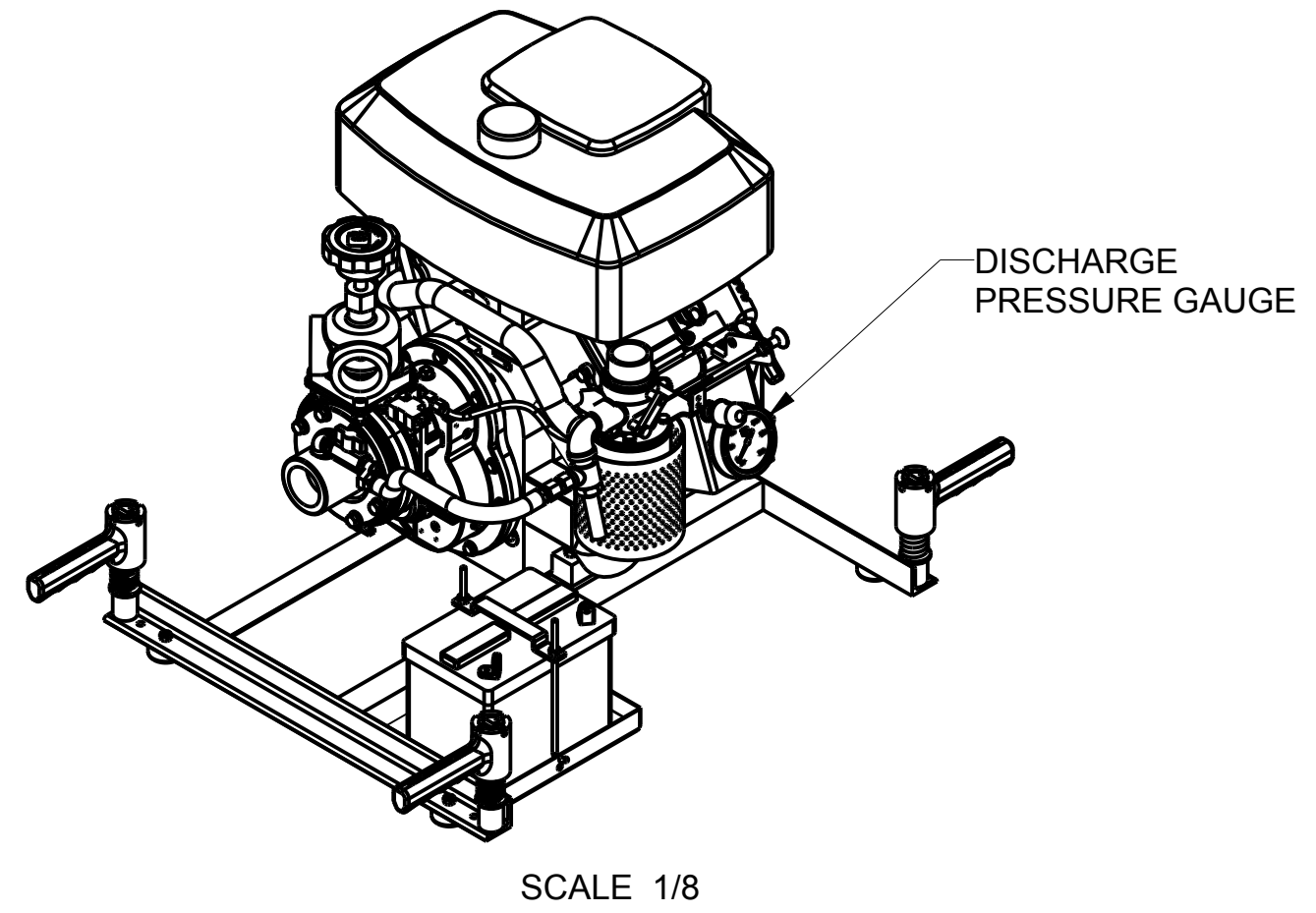

APPROXIMATE WEIGHT: 145 LBS (66 KG)

REMOVE SHARP EDGES		INCH (MILLIMETER)		TOLERANCE EXCEPT AS NOTED		W.S. Darley & Co. ITASCA, IL - CHIPPEWA FALLS, WI	
MATERIAL DESCRIPTION:		MATERIAL NO.		PATTERN NO.		1.25AGE, 18 HP COOLER/ CLEANER W/ TANK VANGUARD	
THIS DESIGN IS THE PROPERTY OF W.S. DARLEY AND CO. - UNAUTHORIZED REPRODUCTION IS PROHIBITED		ALL DIMENSIONS IN INCHES UNLESS NOTED		DO NOT SCALE PRINT		DATE 25-May-07	
DRN JWG/AN		CHKD TED		TRCD		SCALE 1/4	
DAD1503 1		3/14/07		1/1		D	
DAD1503							