

REVISIONS				
LTR	DESCRIPTION	DATE	CHG NO.	APPR'D

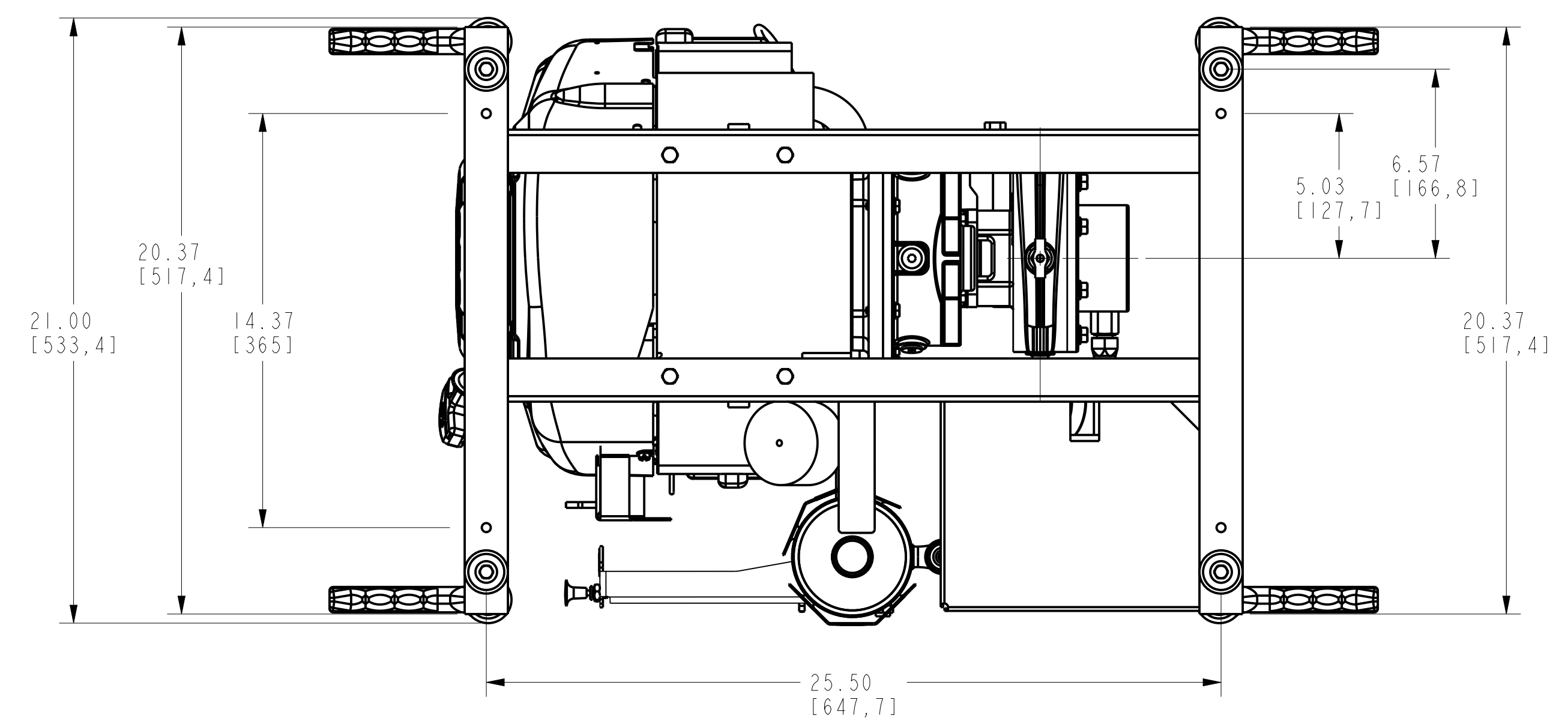
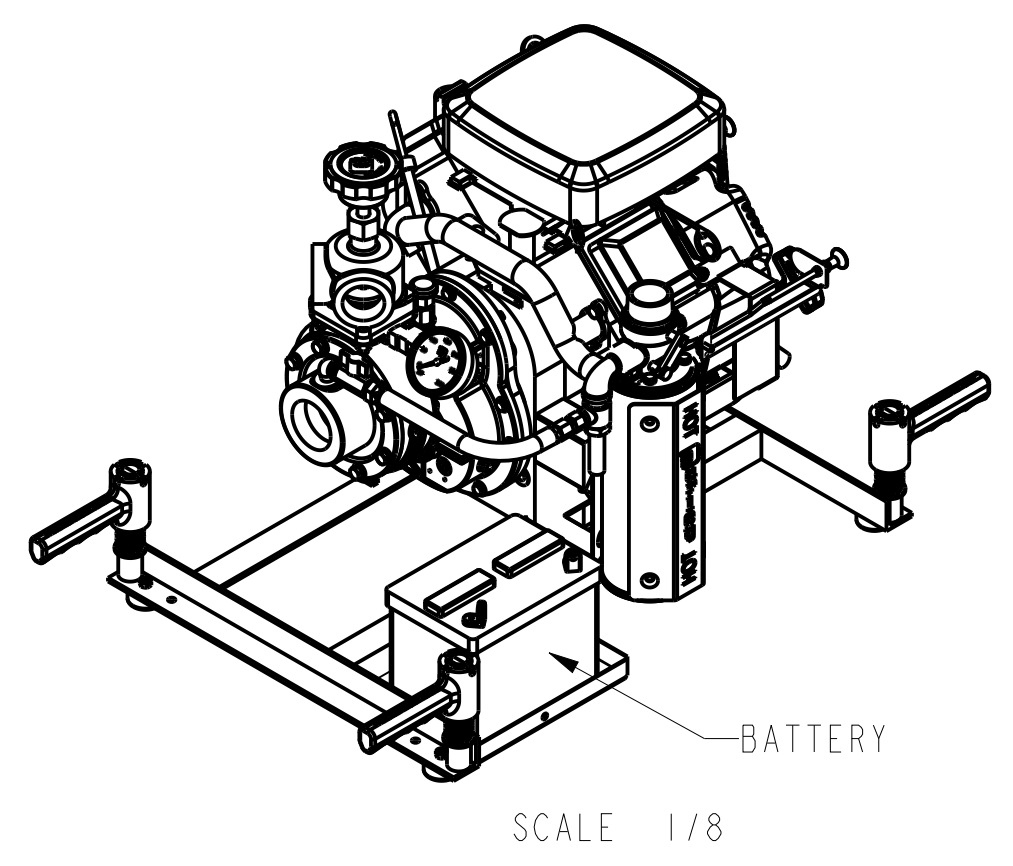
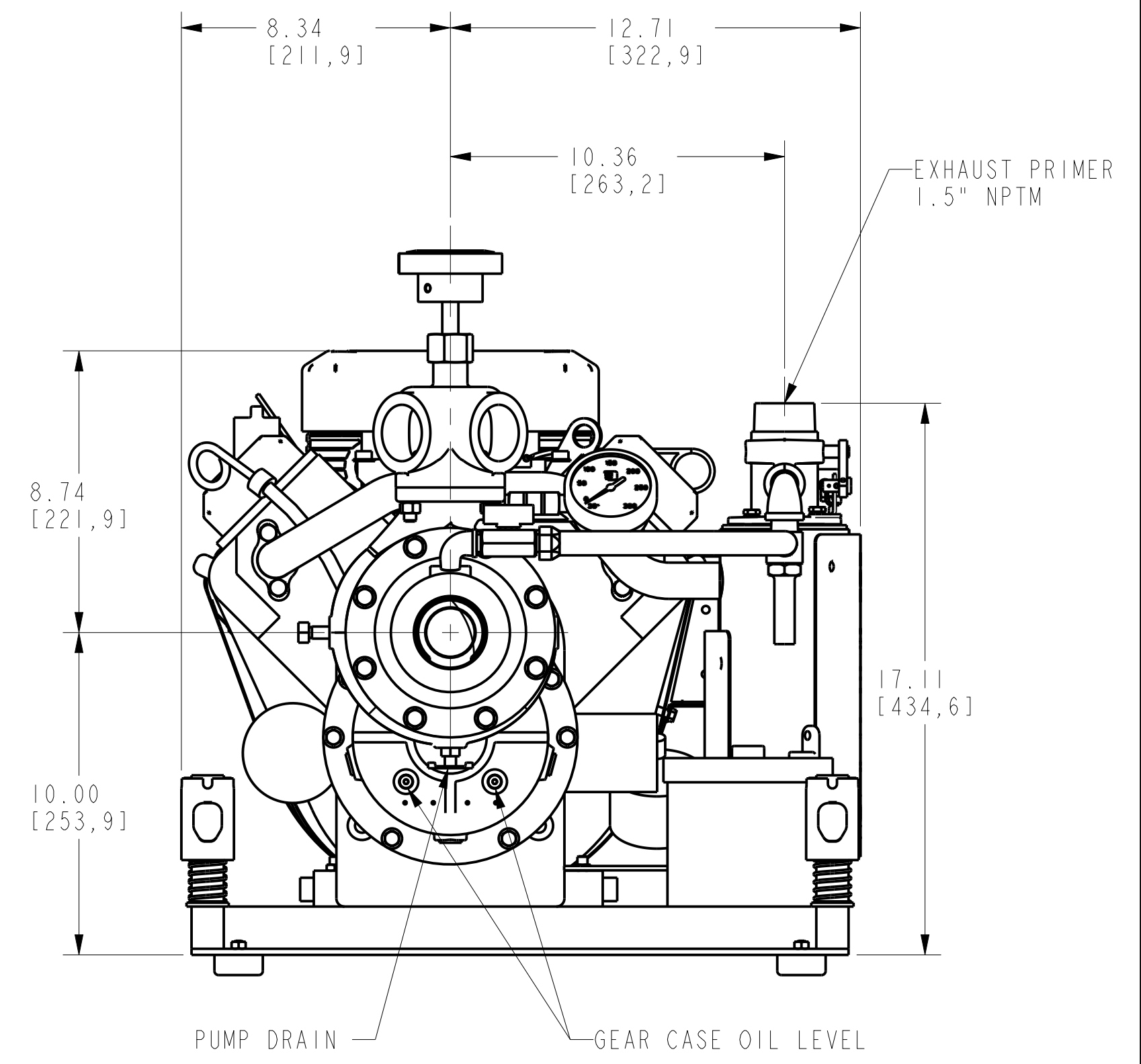
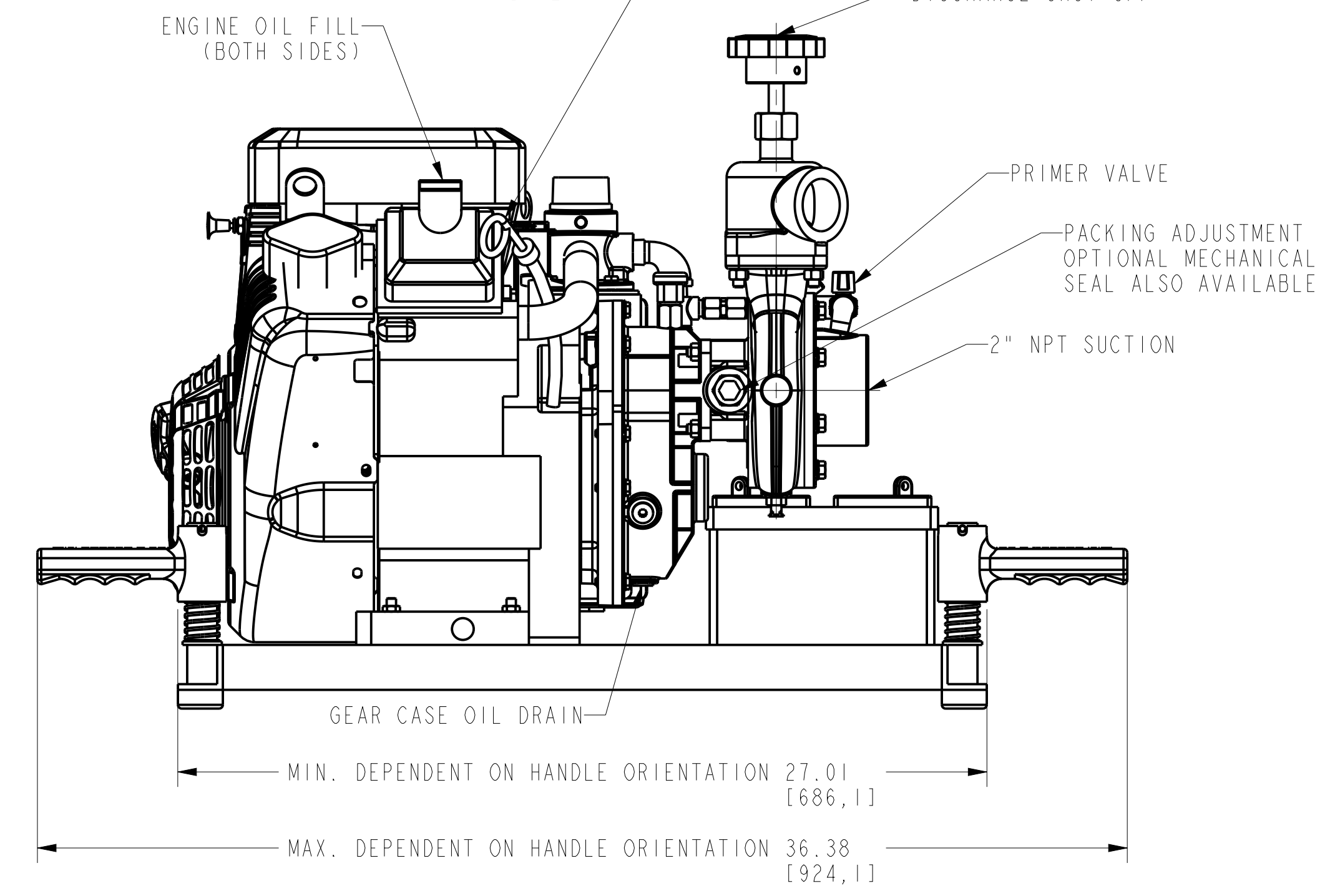
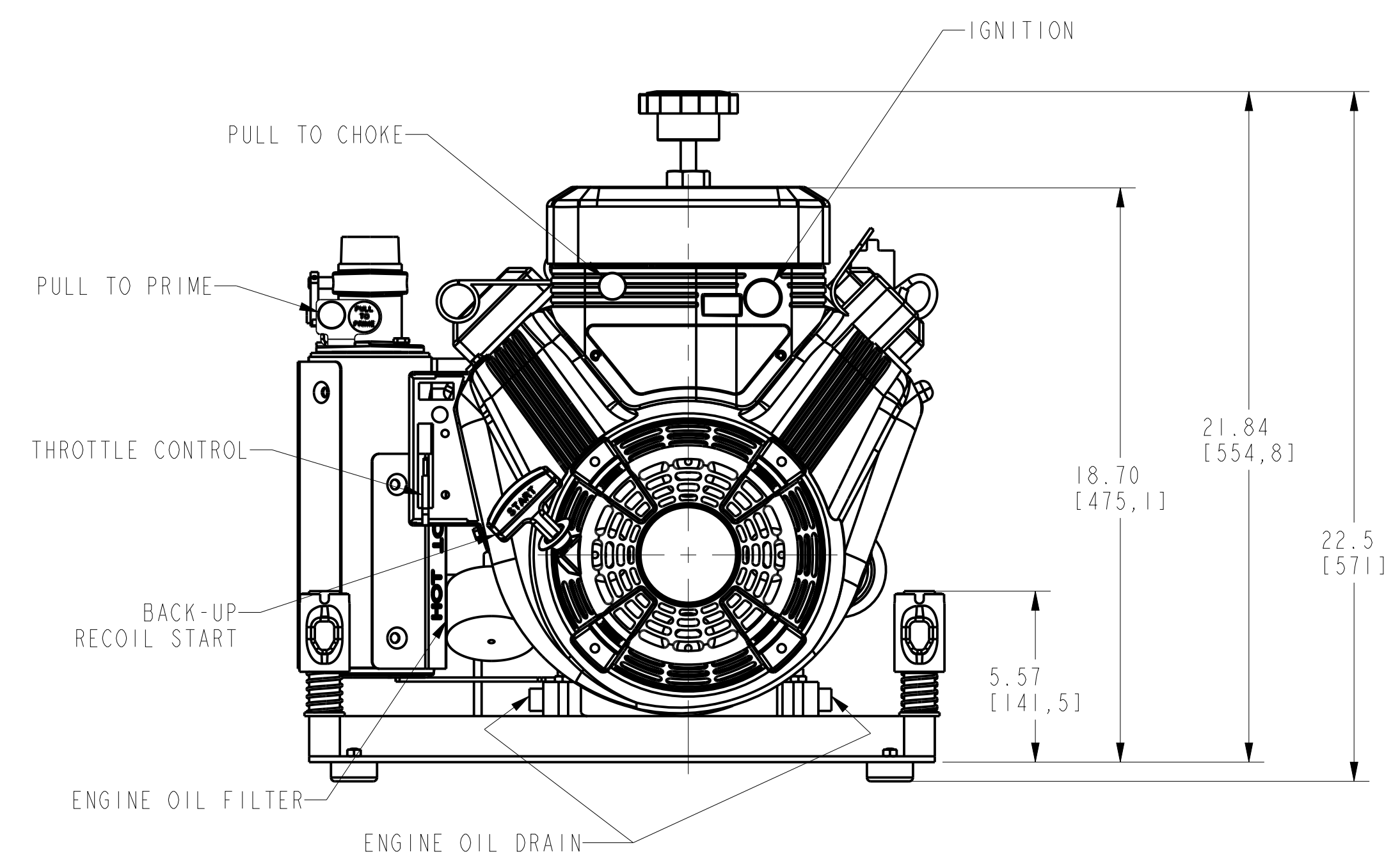
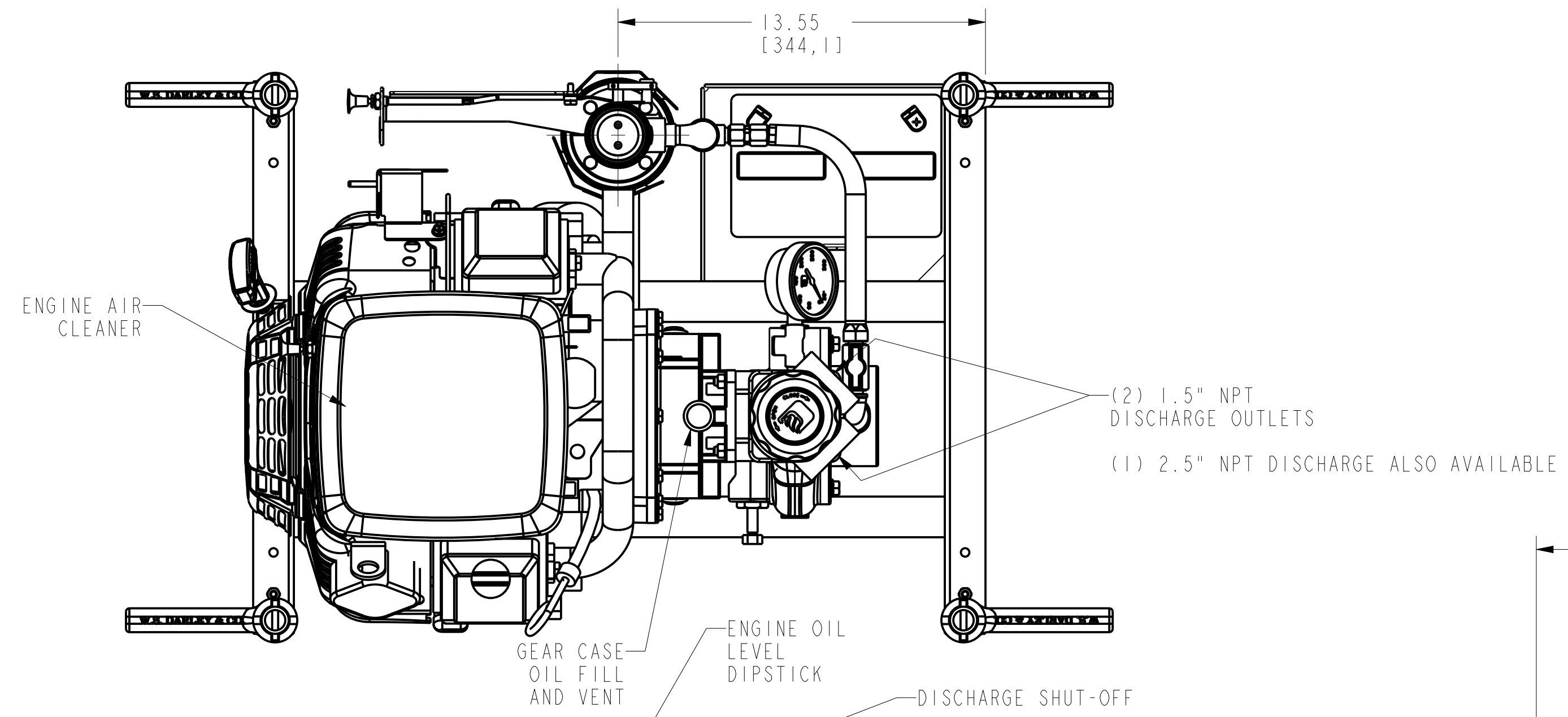
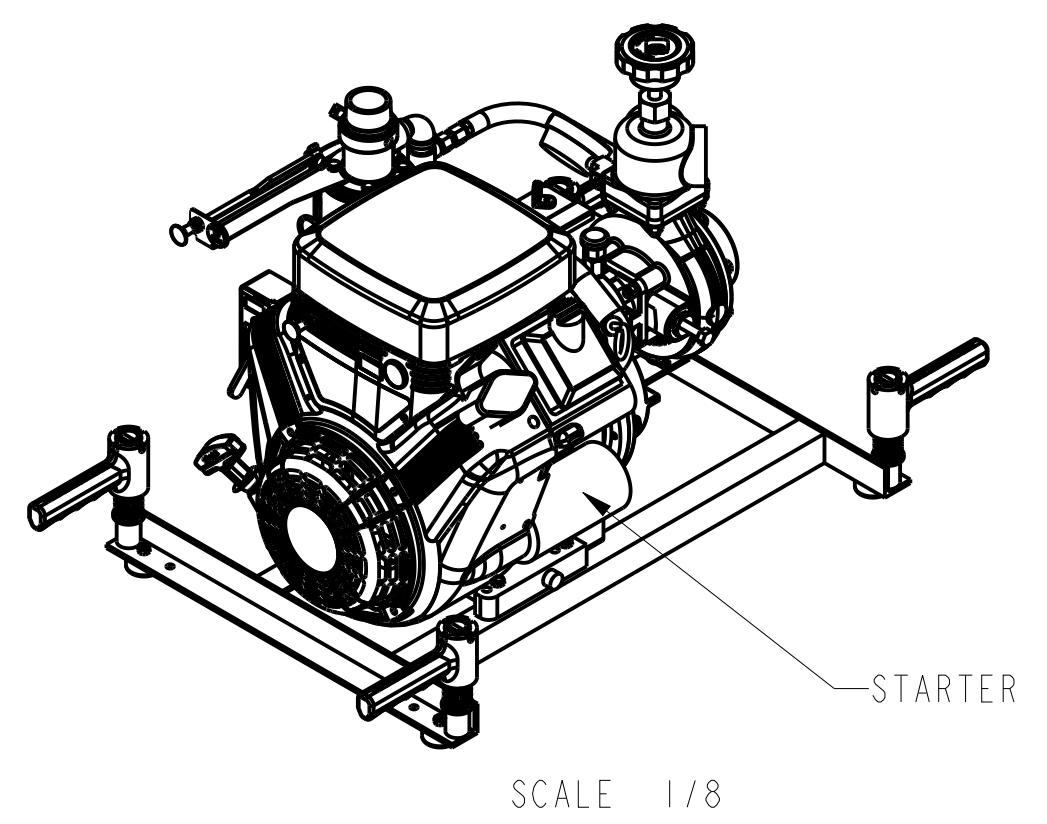

APPROXIMATE WEIGHT: 146 LBS (66 KG)

REMOVE SHARP EDGES		INCH (MILLIMETER)		TOLERANCE EXCEPT AS NOTED 0.00 ± 0.03 0.000 ± 0.010 ANGLES ± 1°		DWG - 1.5AGE, 18HP VAN. PORT NO FUEL TANK, NO CONTROL	
MATERIAL DESCRIPTION: ALUMINUM		MATERIAL NO. PATTERN NO.		DR'N TED		DATE 11-Nov-13	
THIS DESIGN IS THE PROPERTY OF W.S. DARLEY AND CO. - UNAUTHORIZED REPRODUCTION IS PROHIBITED		DO NOT SCALE PRINT		CHWD AAN TRCD		SCALE 1/4	
MODEL NAME: DAD0712		MOL CREATED: 28OCT2013		SHEET: 1/1		D	
W.S. Darley & Co. ITASCA, IL - CHIPPEWA FALLS, WI		DAD0712		11		DAD0712	