

REVISIONS				
LTR	DESCRIPTION	DATE	CHG NO.	APPRD

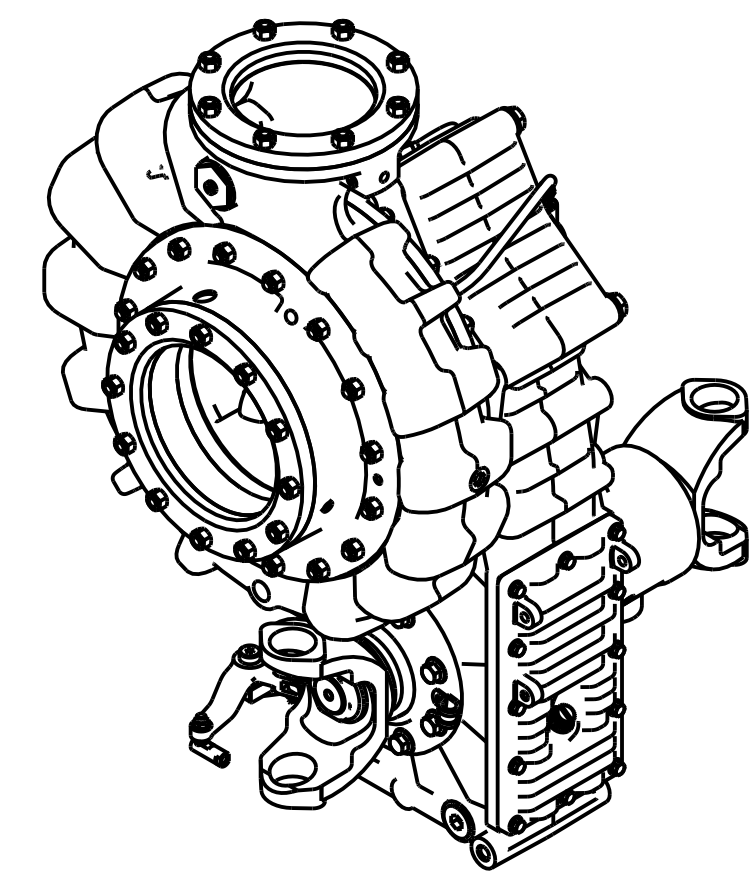

YOKE SERIES	A	B
1550	5.75 [146.1]	24.60 [624.8]
1610	6.12 [155.4]	25.34 [643.6]
1710	5.63 [143.0]	24.36 [618.7]
1760	6.00 [152.4]	25.10 [637.5]
1810 (SHOWN)	5.88 [149.4]	24.86 [631.4]

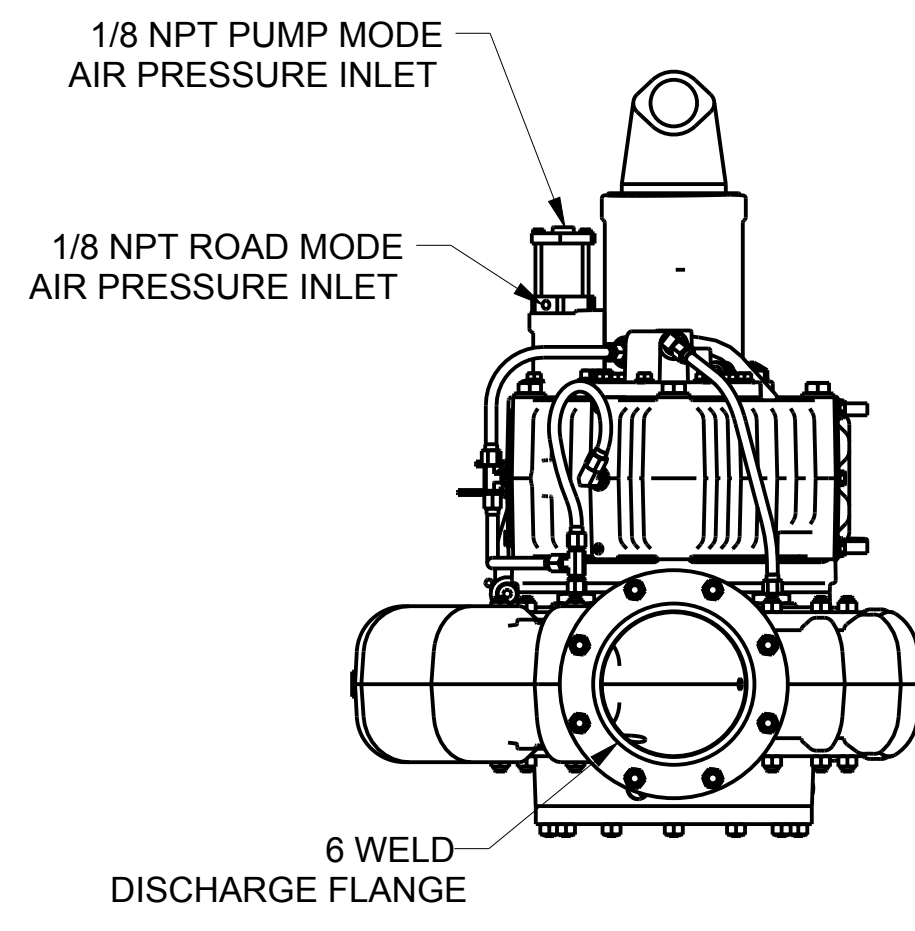
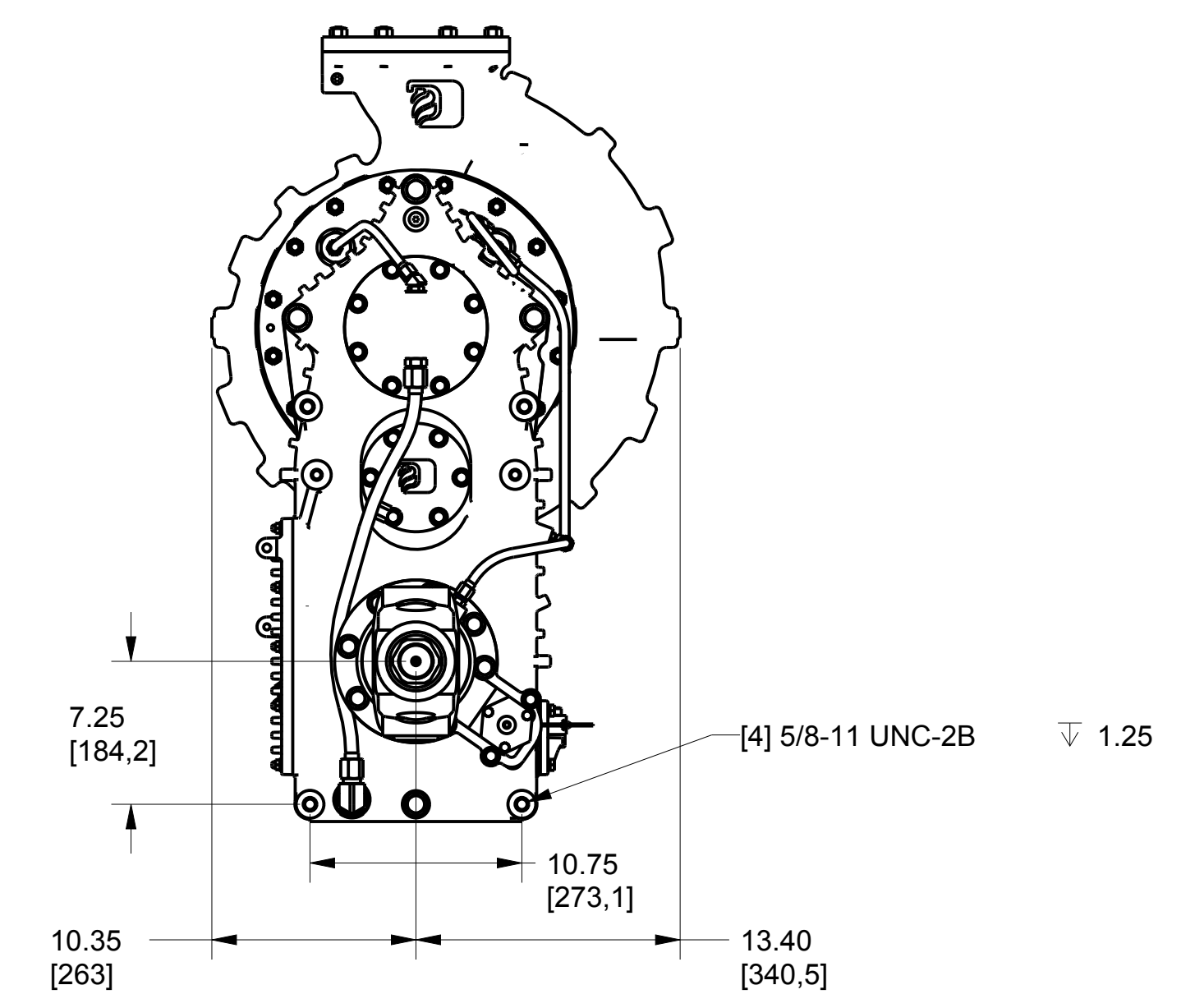
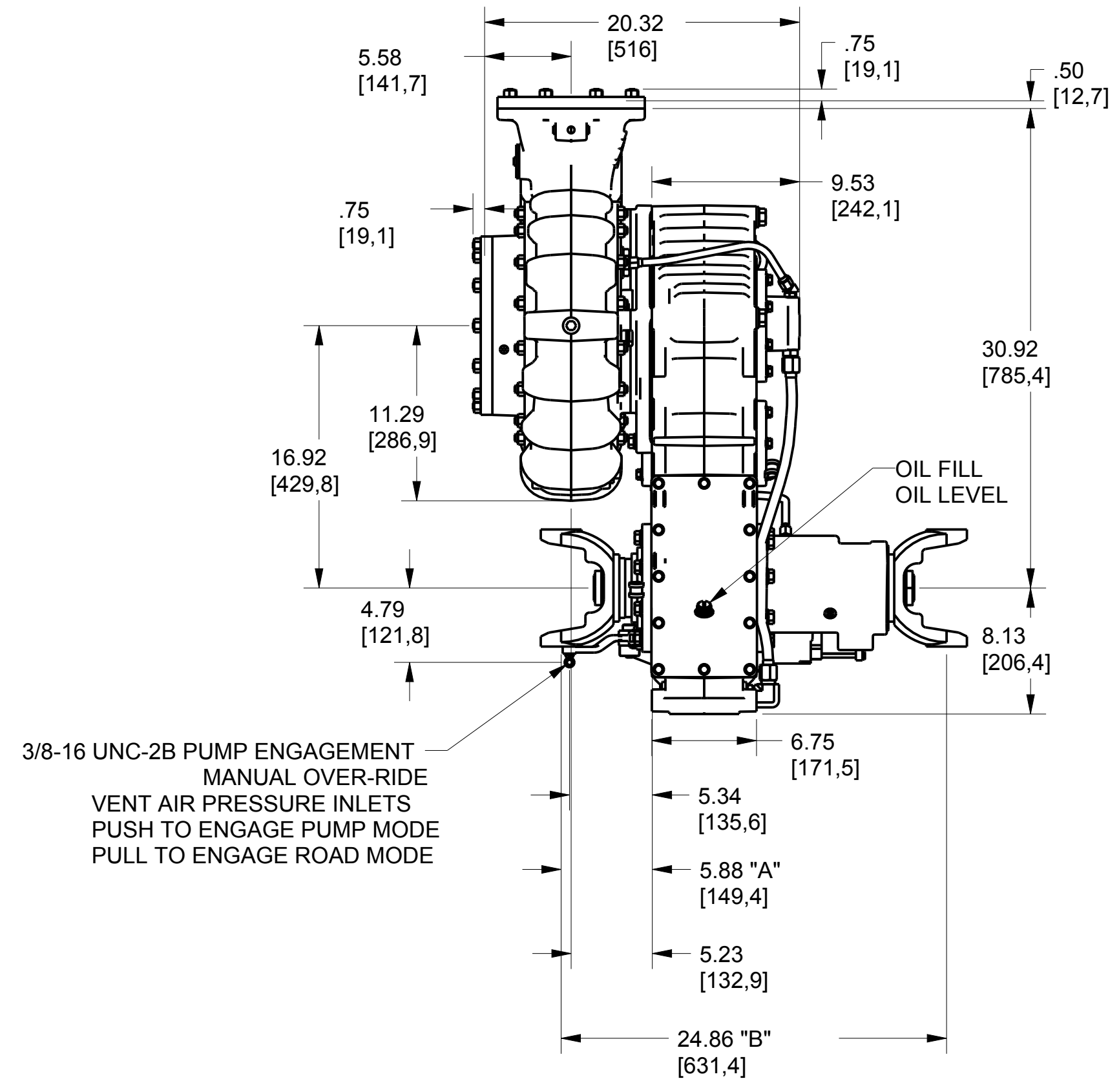
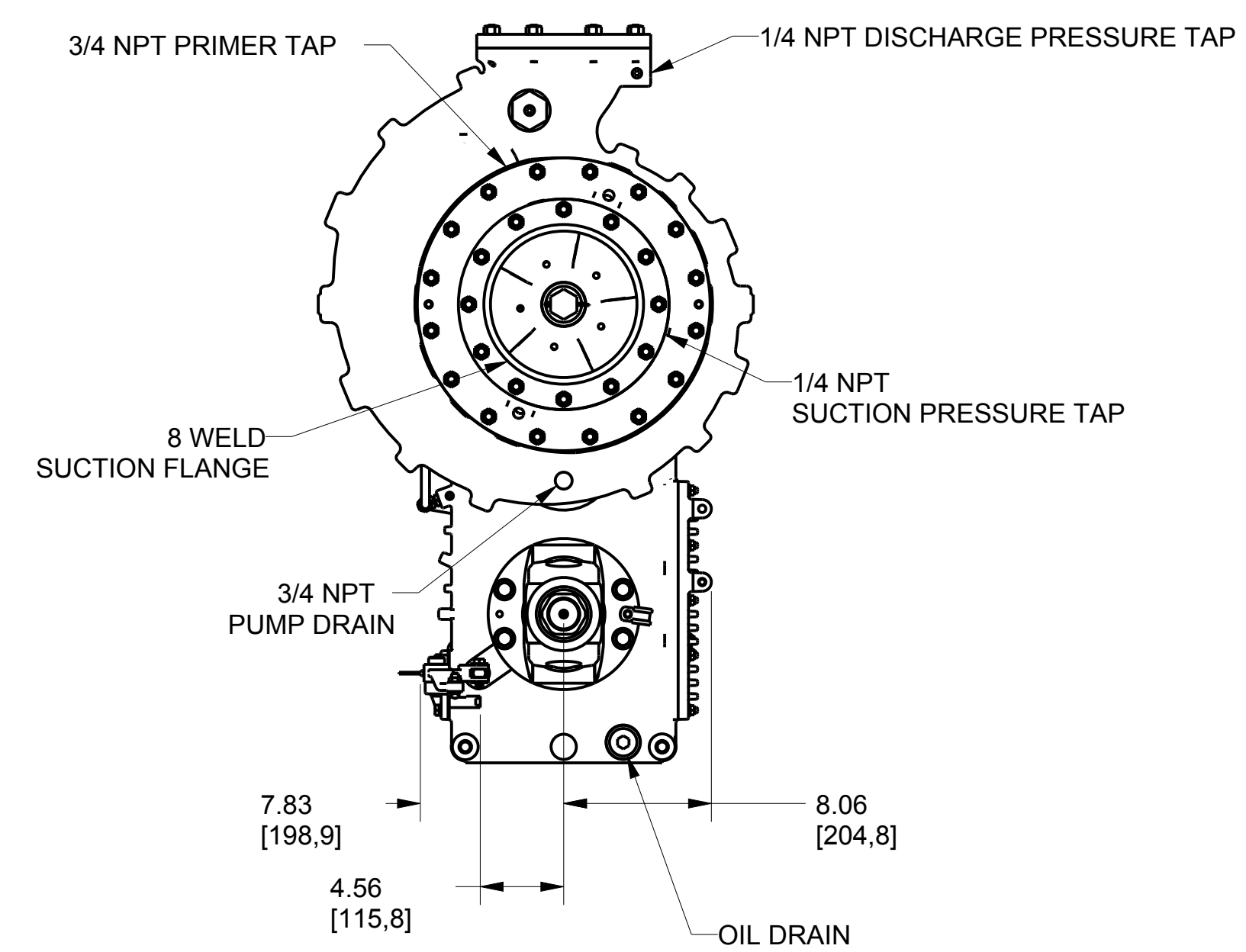

VIEW FROM THE ENGINE TO THE PUMP

VIEW FROM THE PUMP TO THE ENGINE

REMOVE SHARP EDGES		INCH [MILLIMETER]	OLD PART NO.	TOLERANCE EXCEPT AS NOTED	W.S. Darley & Co. ITASCA, IL - CHIPPEWA FALLS, WI
MATERIAL DESCRIPTION:	MATERIAL NO.	PATTERN NO.	00 ±.03 2000 ±.010 ANGLES ±1°	DWG - DIMENSIONAL ZSM, 3 GEAR, PUMP FORWARD WELD FLANGE DISCHARGE, WELD FLANGE SUCTION	DATE 20JUL2010
THIS DESIGN IS THE PROPERTY OF W.S. DARLEY AND CO. - UNAUTHORIZED REPRODUCTION IS PROHIBITED		ALL DIMENSIONS IN INCHES UNLESS NOTED	DO NOT SCALE PRINT	DRN WAH CHKD TRCD	SCALE 1/8

DZD0007