

REVISIONS				
LTR	DESCRIPTION	DATE	CHG NO.	APPRD

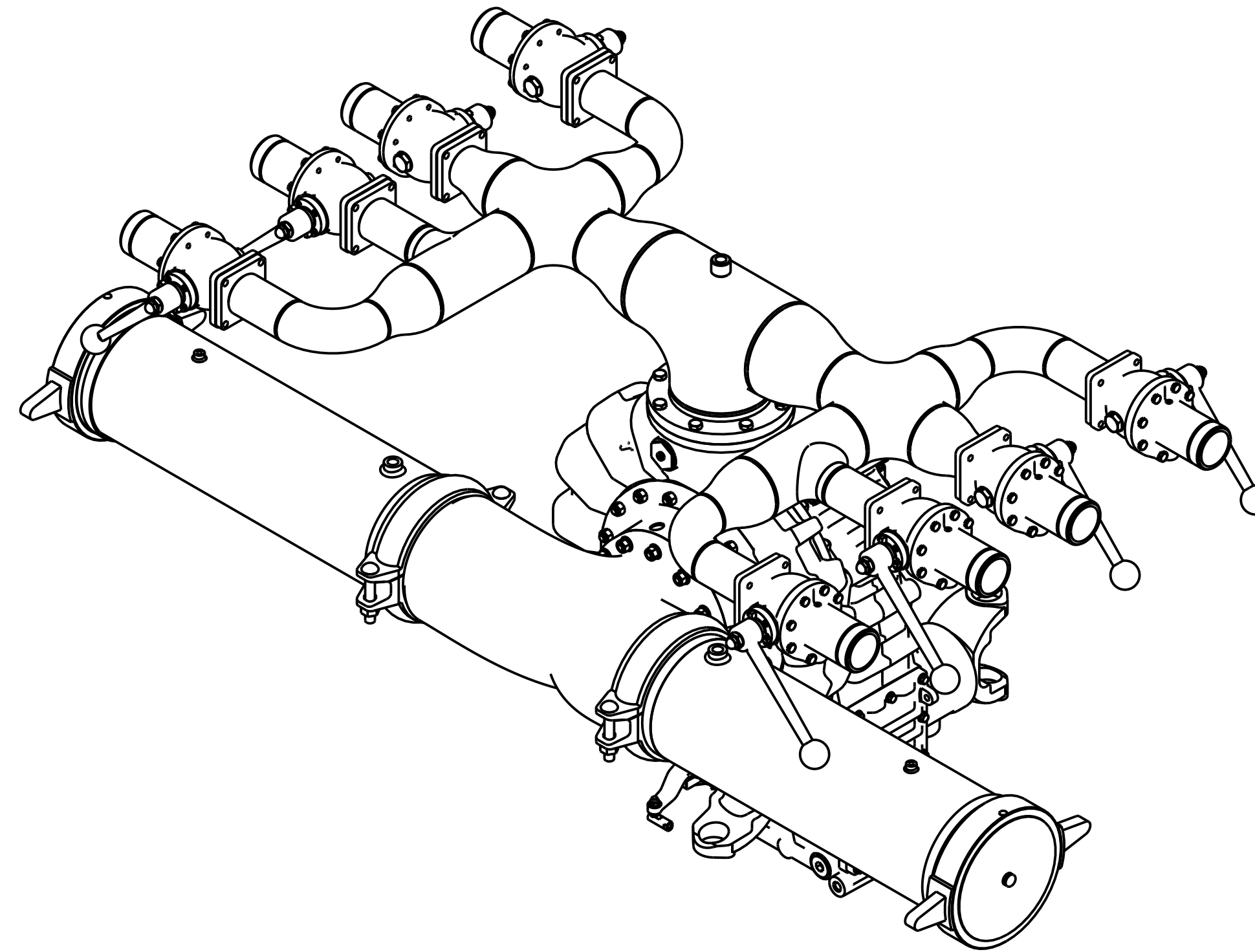

YOKE SERIES	A	B
1550	5.75 [146.1]	24.60 [624.8]
1610	6.12 [155.4]	25.34 [643.6]
1710	5.63 [143.0]	24.36 [618.7]
1760	6.00 [152.4]	25.10 [637.5]
1810 (SHOWN)	5.88 [149.4]	24.86 [631.4]

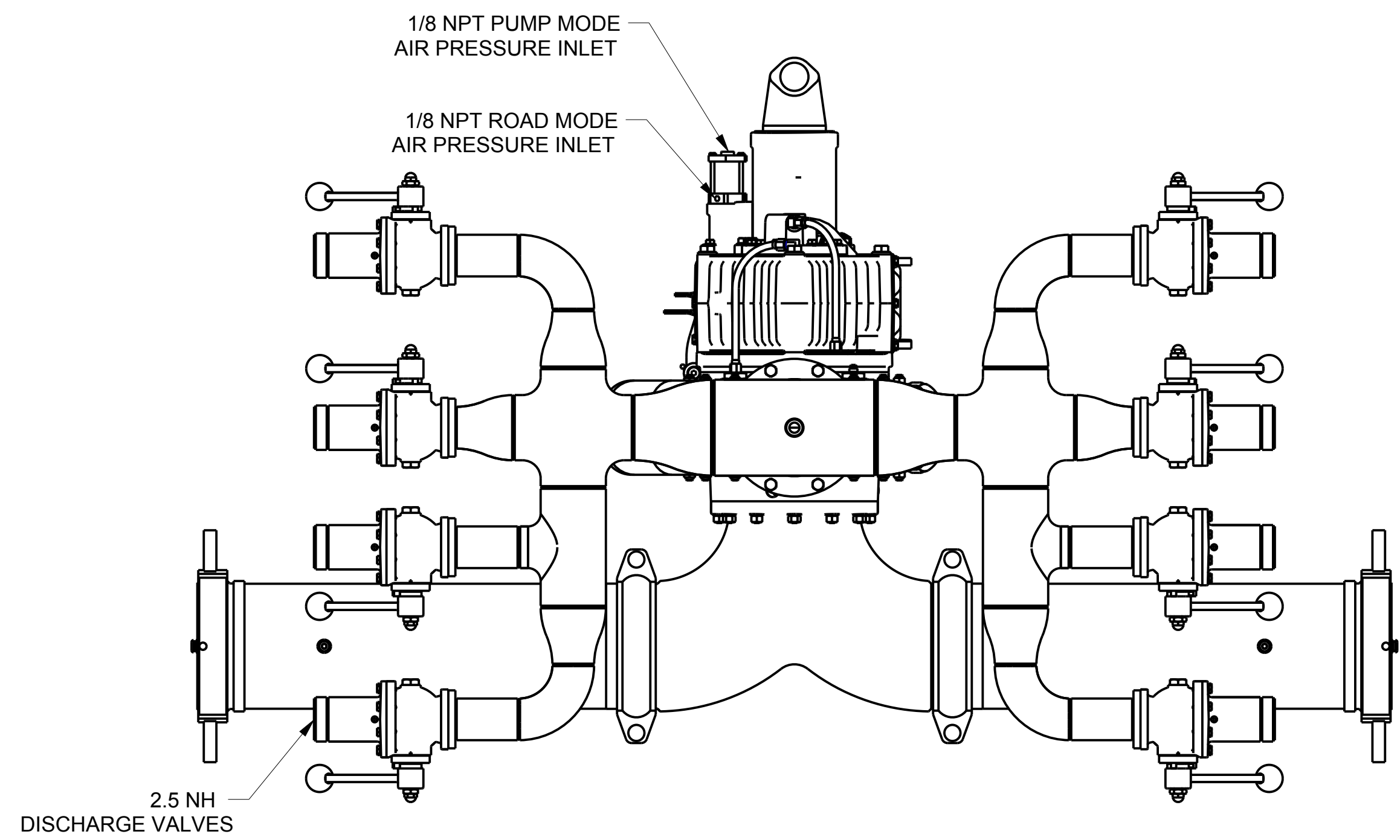
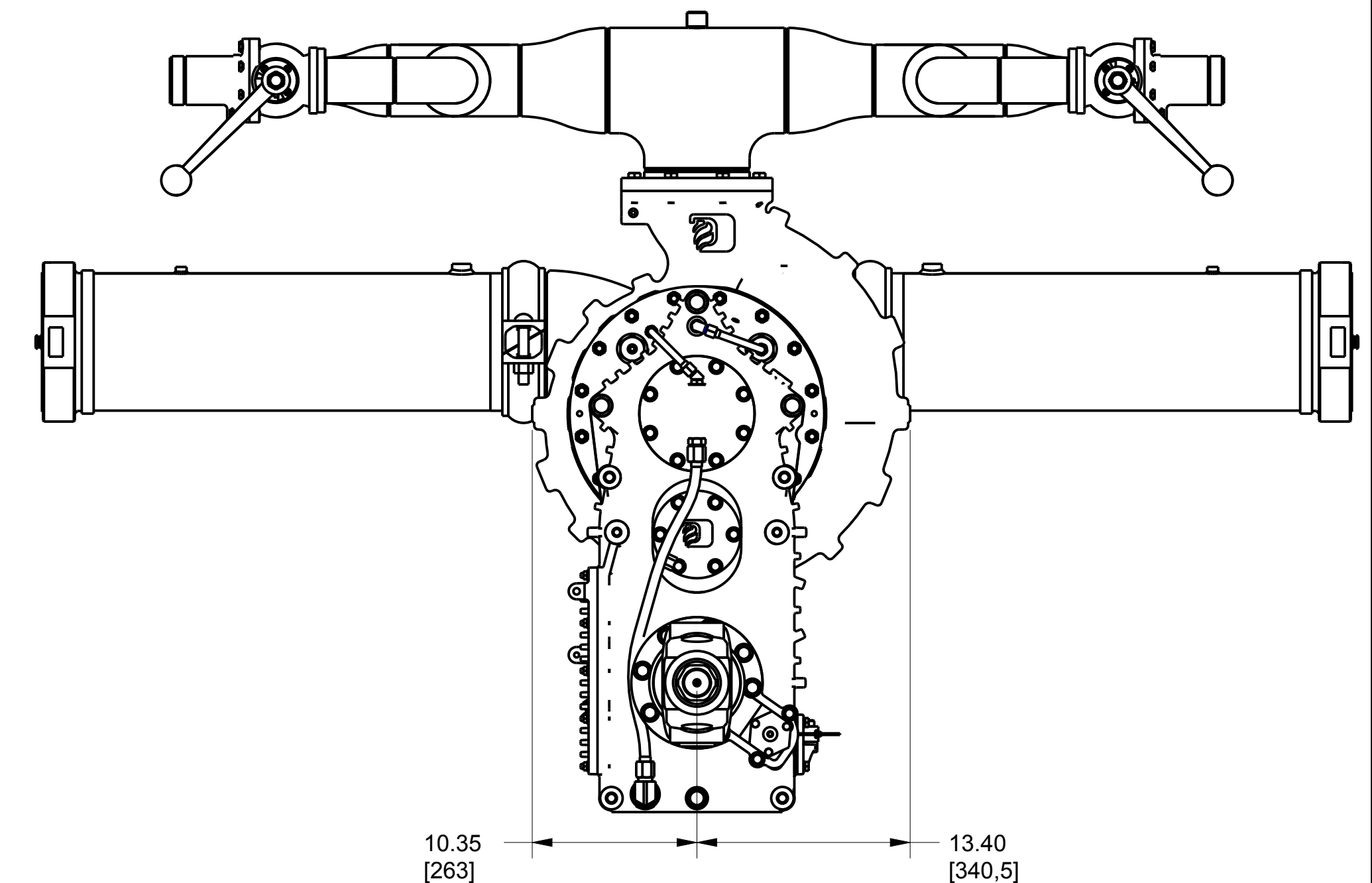
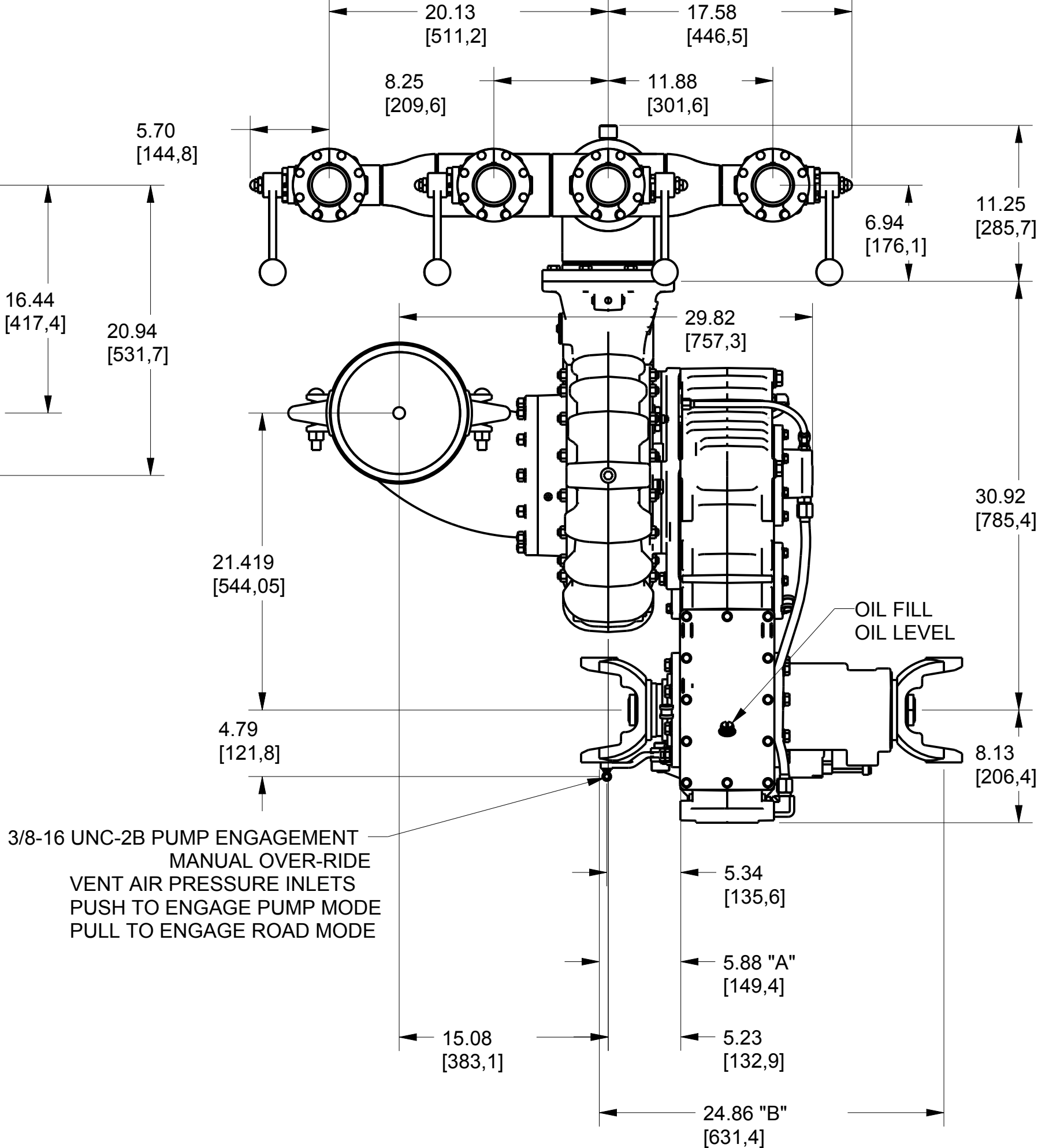
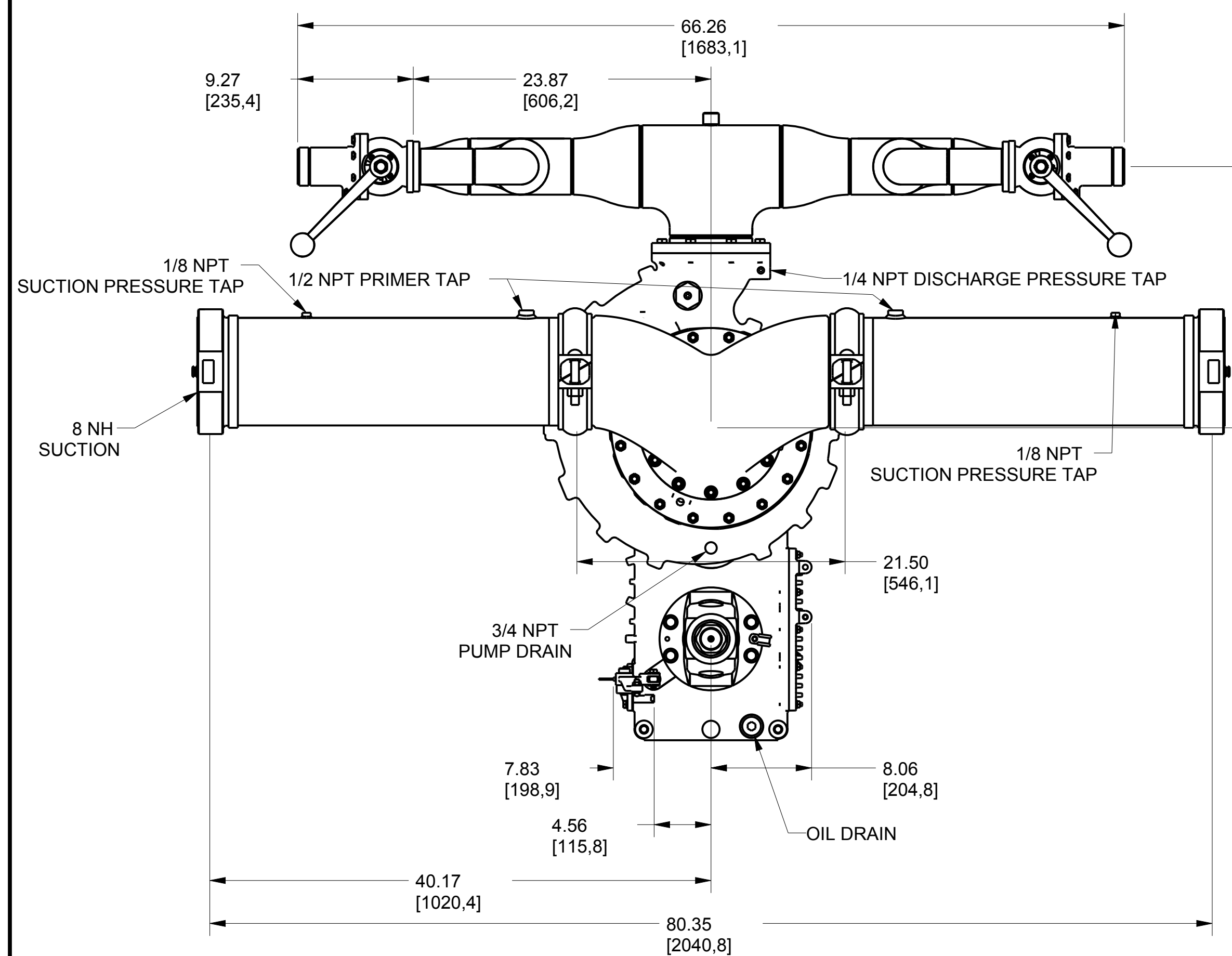

VIEW FROM THE PUMP TO THE ENGINE

VIEW FROM THE ENGINE TO THE PUMP

REMOVE SHARP EDGES

INCH [MILLIMETER]

OLD PART NO.

TOLERANCE EXCEPT AS NOTED

W.S. Darley & Co. ITASCA, IL - CHIPPEWA FALLS, WI

DWG - DIMENSIONAL, ZSM, 3 GEAR, PUMP FORWARD STAINLESS DISCHARGE HEAD, 8 SWEEP TEE PIPED SUCTION

DATE 20JUL2010

SCALE 1/8

DZD0006