

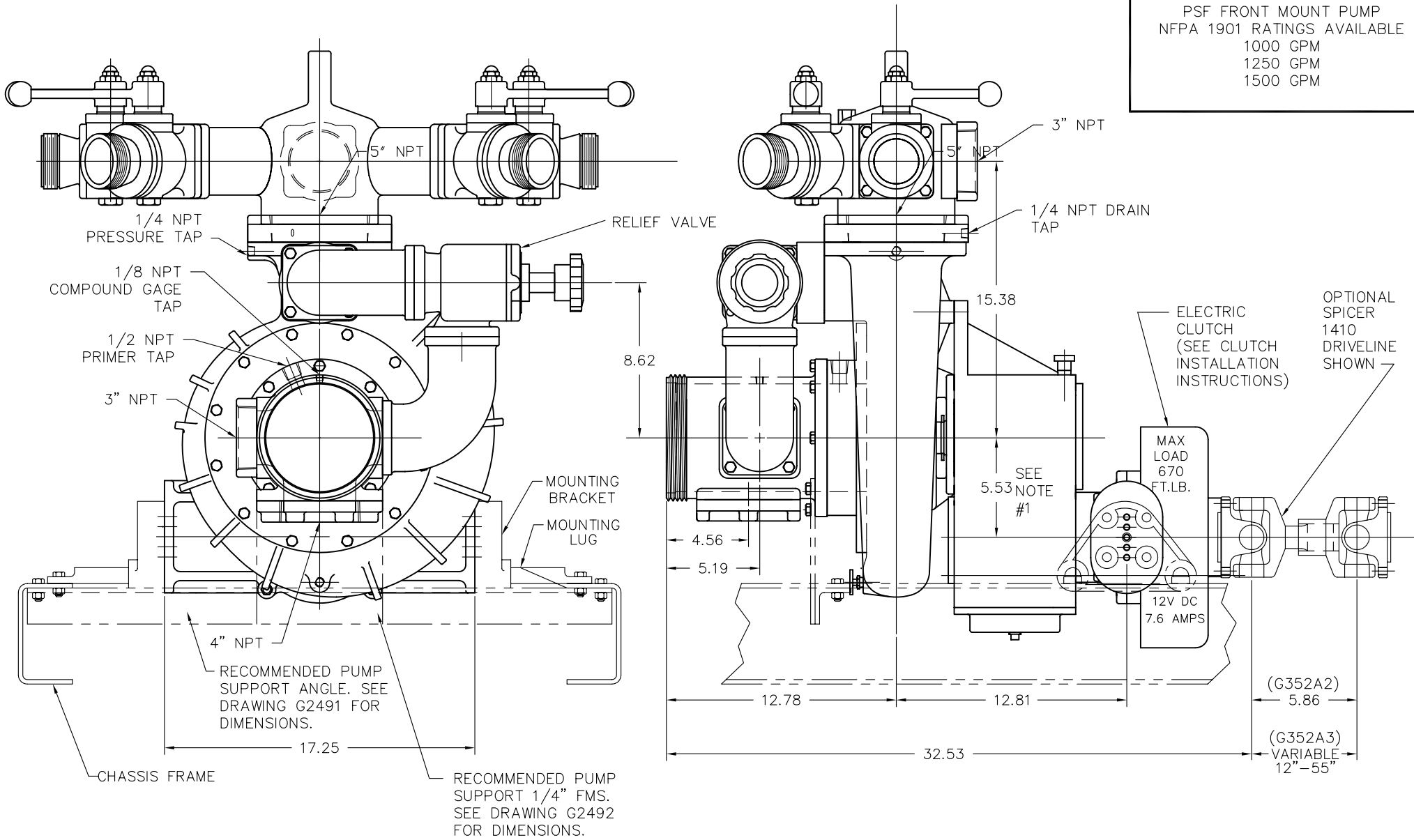

PSF FRONT MOUNT PUMP
 NFPA 1901 RATINGS AVAILABLE
 1000 GPM
 1250 GPM
 1500 GPM



NOTES:

1) GEARCASE CAN BE INSTALLED UPSIDE-DOWN RESULTING IN A 5.53 DROP FROM DRIVELINE TO SUCTION CENTERLINE. MANY OTHER POSITIONS ARE AVAILABLE. PLEASE CONTACT W.S. DARLEY'S ENGINEERING DEPARTMENT FOR ADDITIONAL INFORMATION.

MATERIAL:	OLD PART NO. P187
THIS DESIGN IS THE PROPERTY OF W.S. DARLEY AND CO. - UNAUTHORIZED REPRODUCTION IS PROHIBITED	DO NOT SCALE PRINT

PART NO.	DATE	CHANGE
 W.S. DARLEY & CO. MELROSE PARK, IL - CHIPPEWA FALLS, WI		
DWG - PSF DIMENSIONAL		
DR'N	MCR	DATE 11-1-90
CHKD		SCALE 1/4
TRCD TED 11/93		DPD0301