

REVISIONS				
LTR	DESCRIPTION	DATE	CHG NO.	APPRD

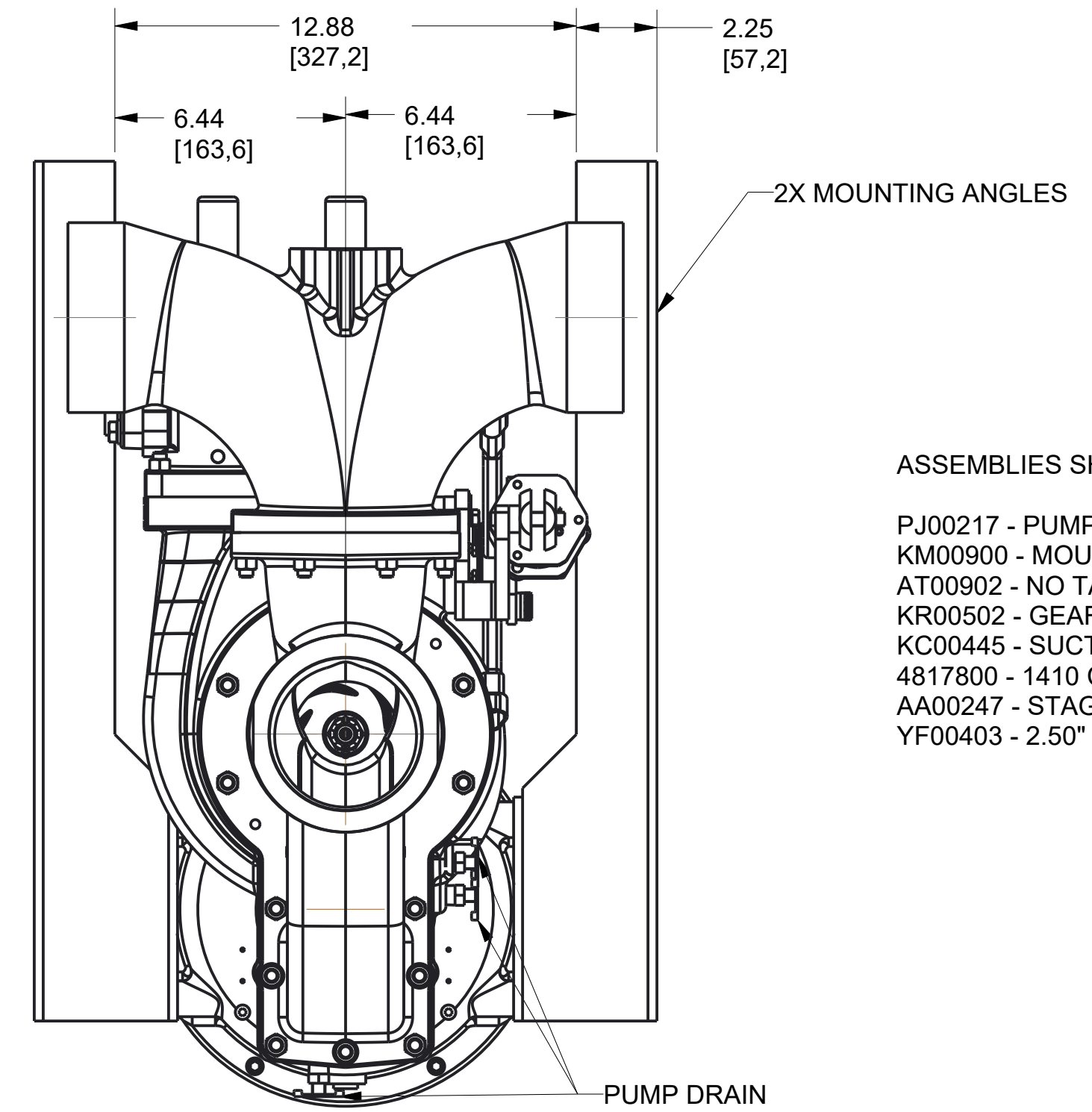
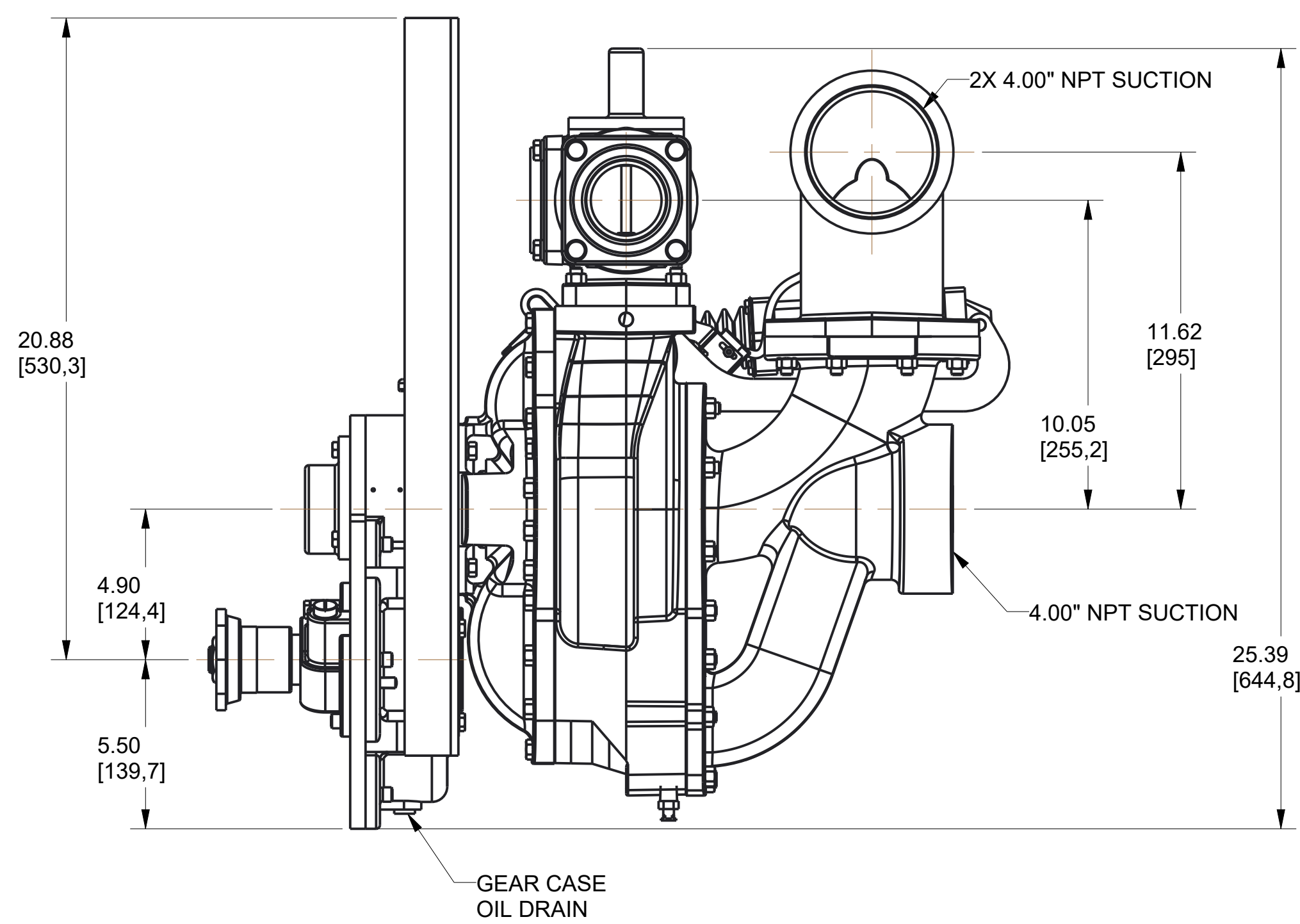
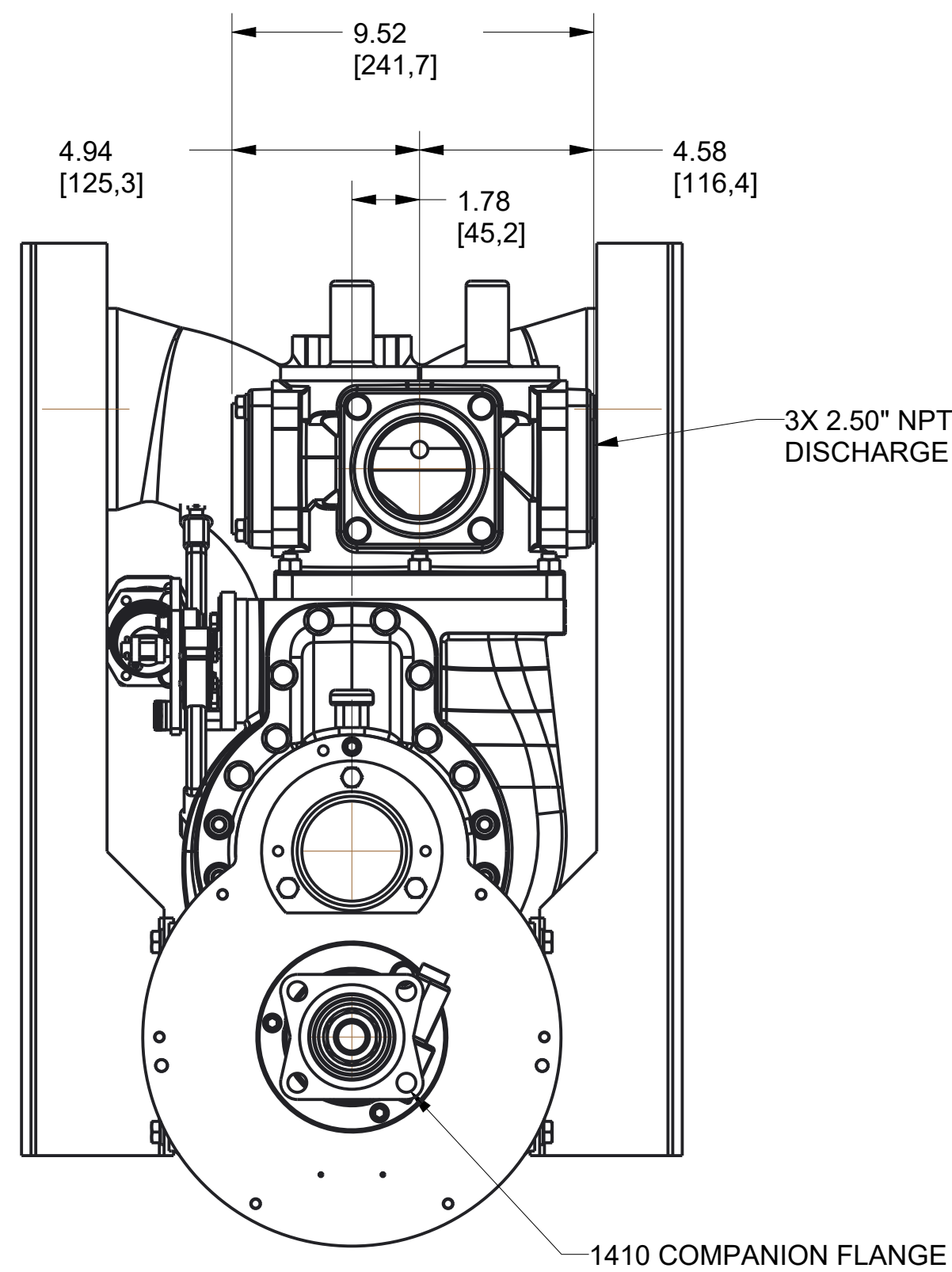
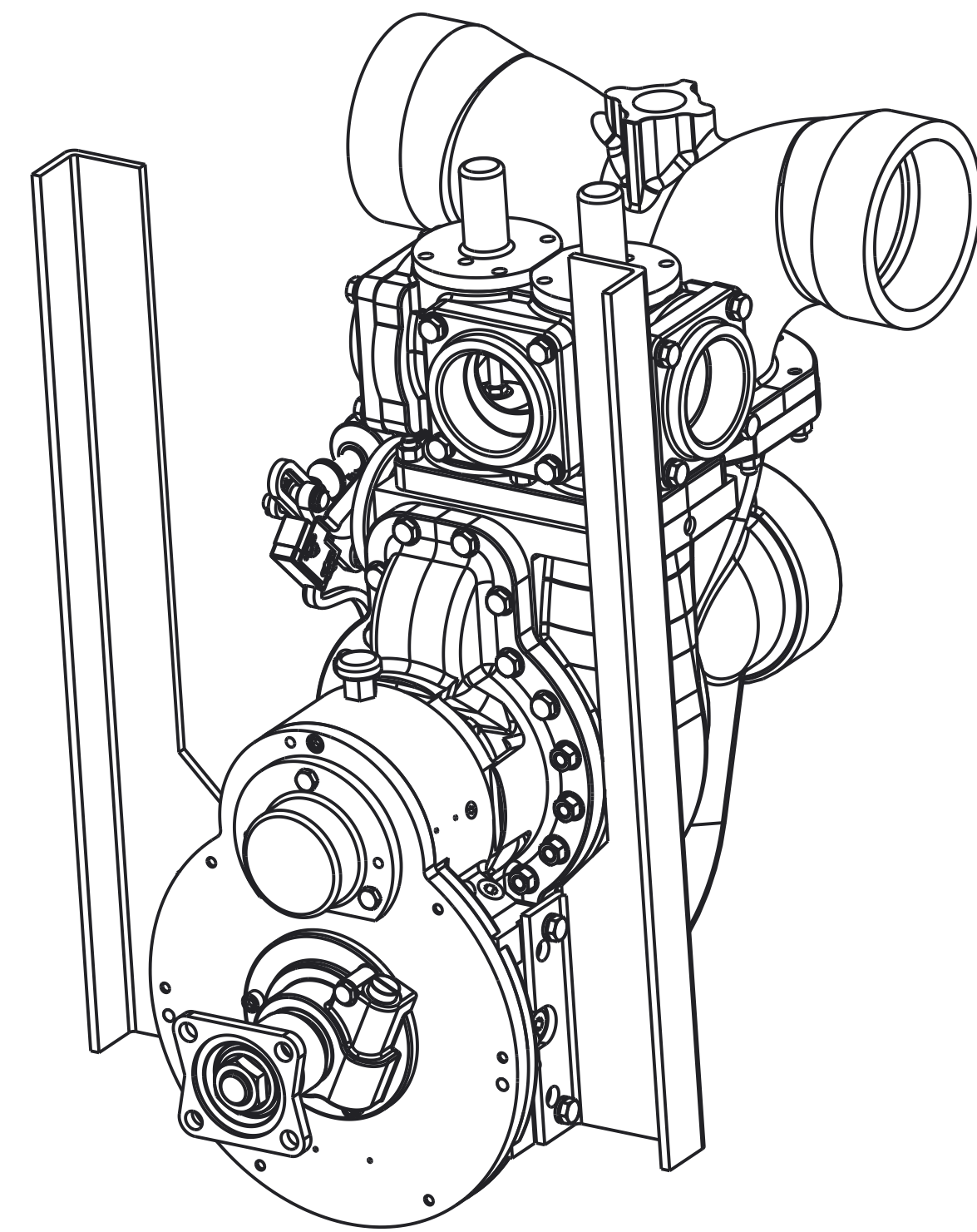
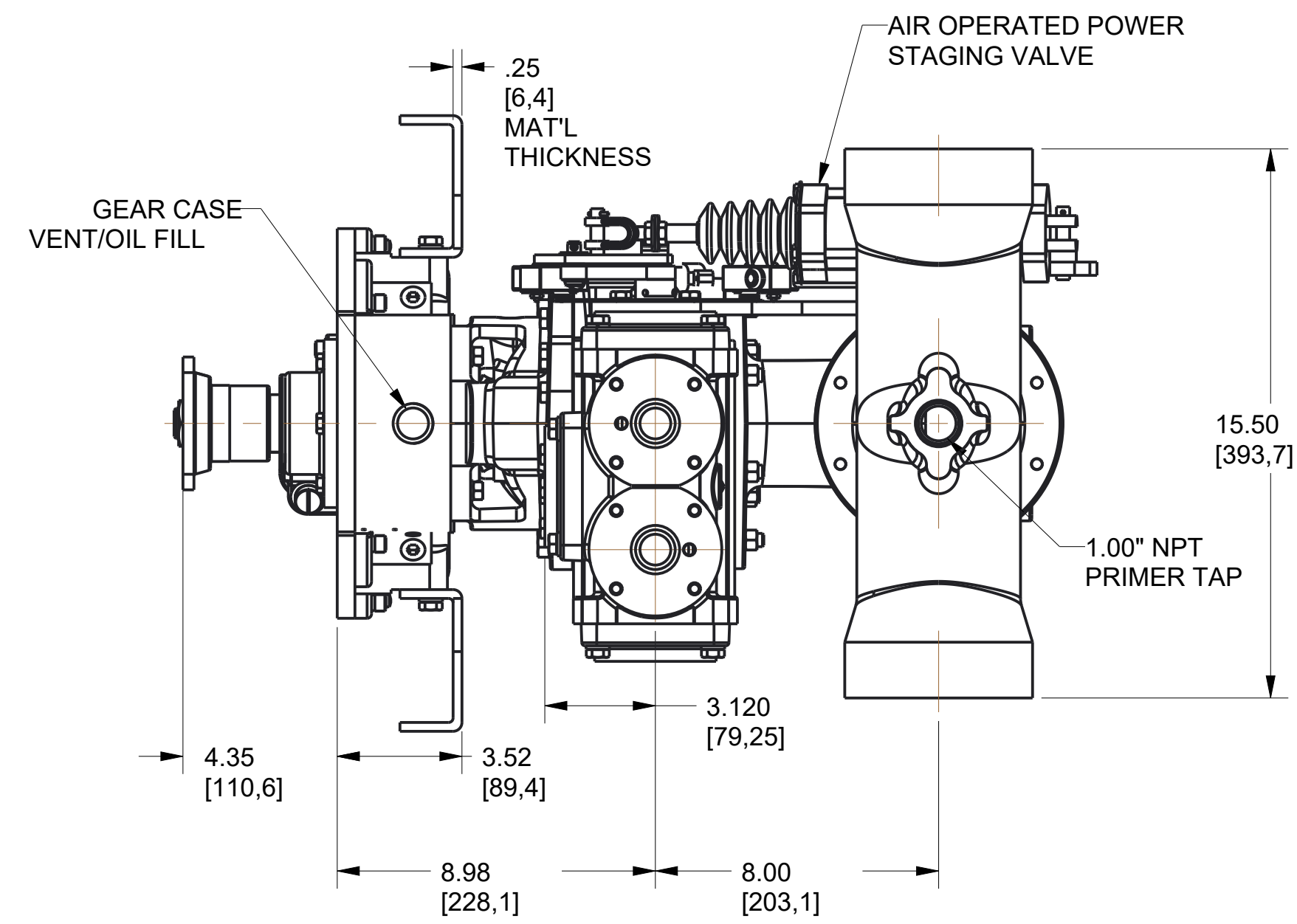
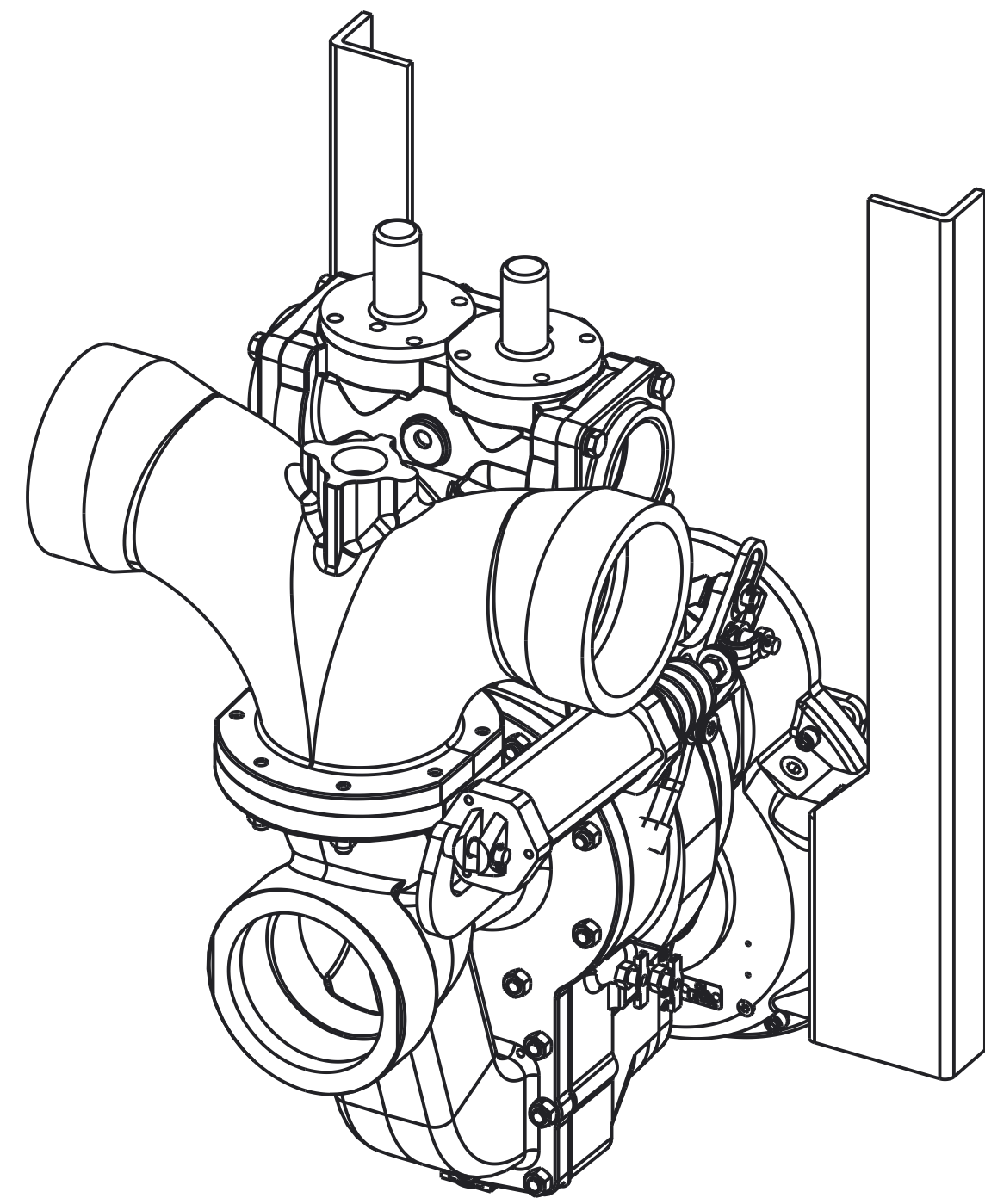

- ASSEMBLIES SHOWN
- PJ00217 - PUMP, TRANS, DISCHARGE HEAD
 - KM00900 - MOUNTING ANGLES
 - AT00902 - NO TACH
 - KR00502 - GEAR RATIO (2.42:1)
 - KC00445 - SUCTION TEE
 - 4817800 - 1410 COMPANION FLANGE
 - AA00247 - STAGING VALVE
 - YF00403 - 2.50" NPT FLANGE

MODEL NAME: DJD0603 MDL CREATED: 28JUN2022 SHEET: 1/1 D

REMOVE SHARP EDGES	INCH (MILLIMETER)	THRU-ANGLE PROVISION	OLD PART NO.	TOLERANCE EXCEPT AS NOTED	W.S. Darley & Co. ITASCA, IL - CHIPPEWA FALLS, WI
MATERIAL DESCRIPTION:			MATERIAL NO.	PATTERN NO.	JMP, 2 GR, MECH, O-RING DIMENSIONAL
THIS DESIGN IS THE PROPERTY OF W.S. DARLEY AND CO. - UNAUTHORIZED REPRODUCTION IS PROHIBITED	ALL DIMENSIONS IN INCHES UNLESS NOTED	DO NOT SCALE PRINT	DRN SMS	DATE 28-Jun-22	DJD0603
			CHKD SLS	SCALE 1/4	