

ITEM NO.	File Name	Darley Item Description (Line 1)	QTY.
1	4229902	ENGINE - KUBOTA, D1803T	1
2	TE00502	TRANS - HE, 2 GEAR, NO TACH	1
3	5400036	HHCS - .375-1.6 x 1.00, GR5	12
4	5401055	SHCS - .313-1.8 X 0.63, GR8	8
5	PH01117	PUMP - HM/HF/HE, MECH, LEFT	1
6	KC04156	KIT - HE4R 4" NPT ALU SUCTION	1
7	YF02932	ASSY - FLANGE, 3 NPT, BLK ANODIZED	1
8	4229900	PRESSURE TRANSDUCER	1
9	1081007	NIPPLE - PIPE, 0.25 X 1.50, SS	1
10	1080404	TEE - PIPE, 0.250, SS	1

REVISIONS					
ZONE	REV.	DESCRIPTION	DATE	CHG NO.	APPROVED
	A	UPDATED ENGINE 3D MODEL	8/14/2019	12409	SMS

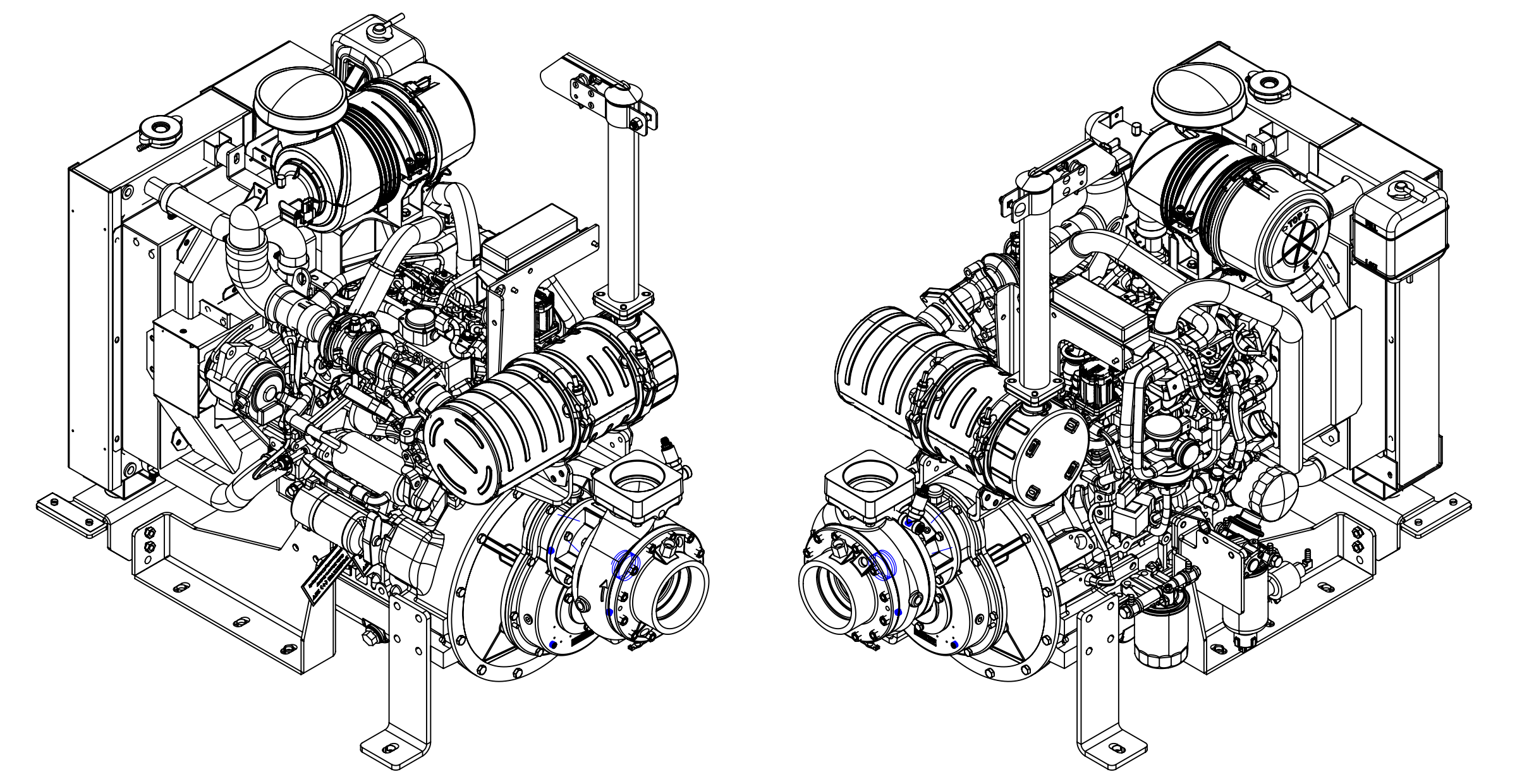
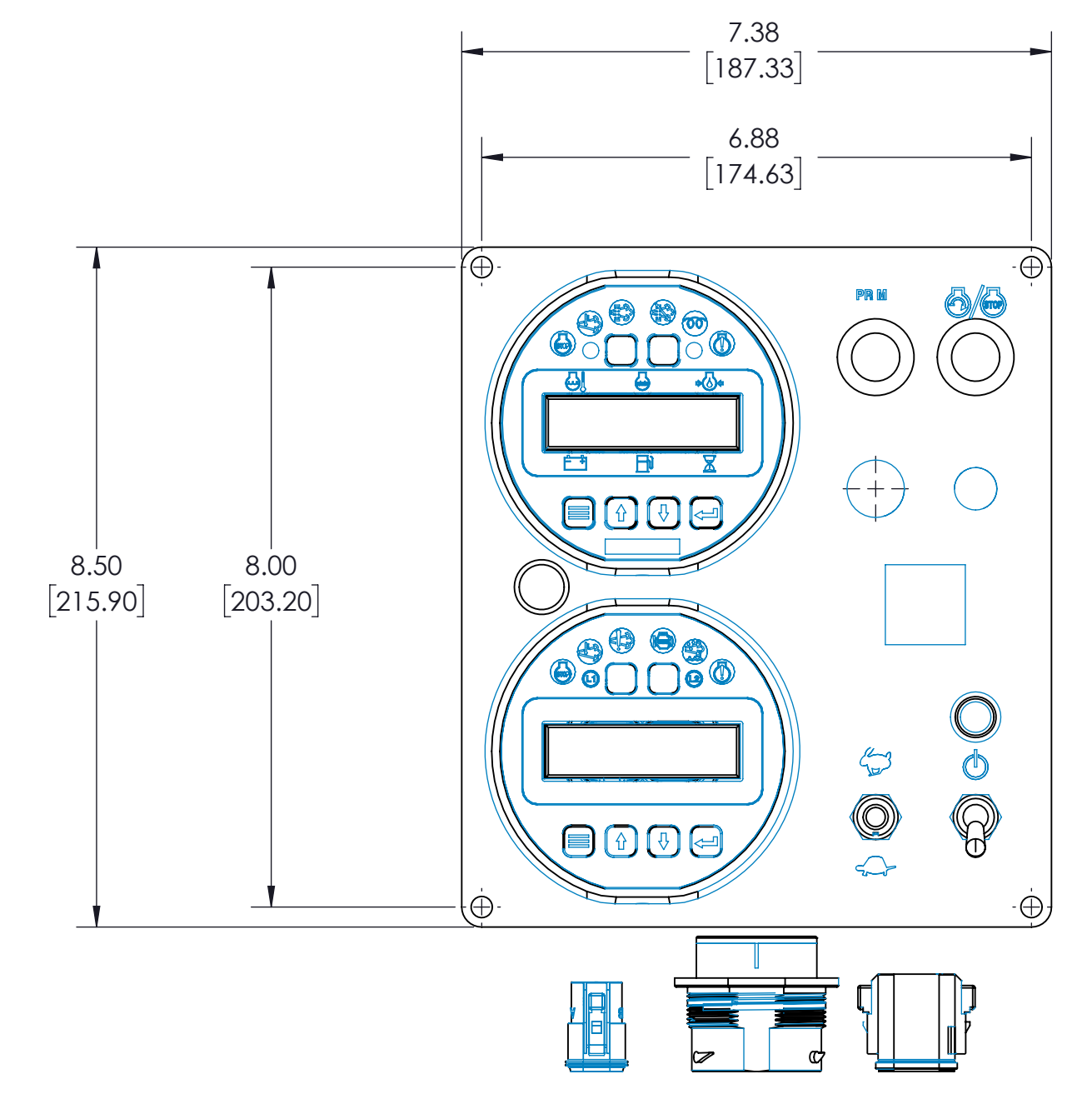
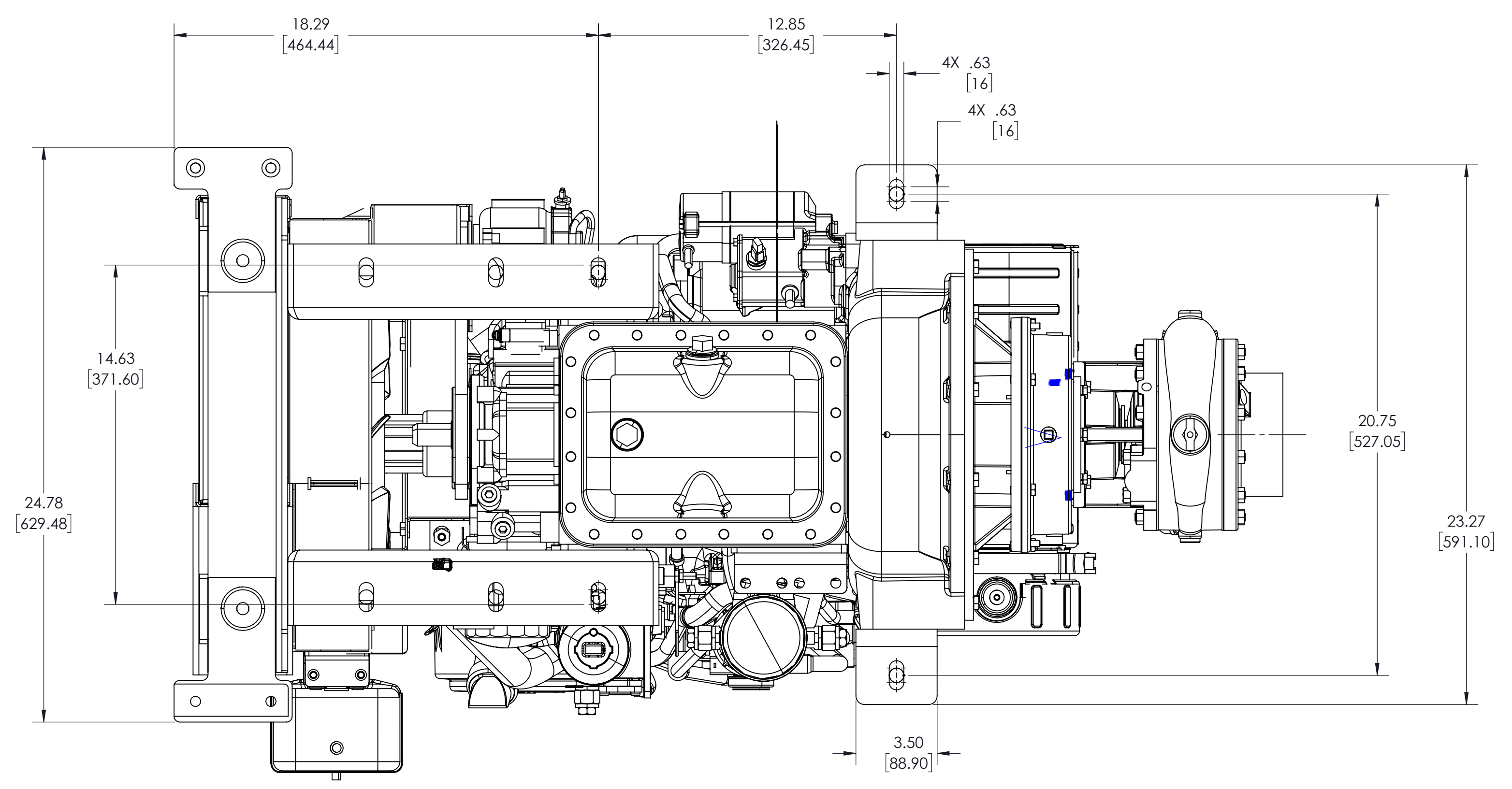
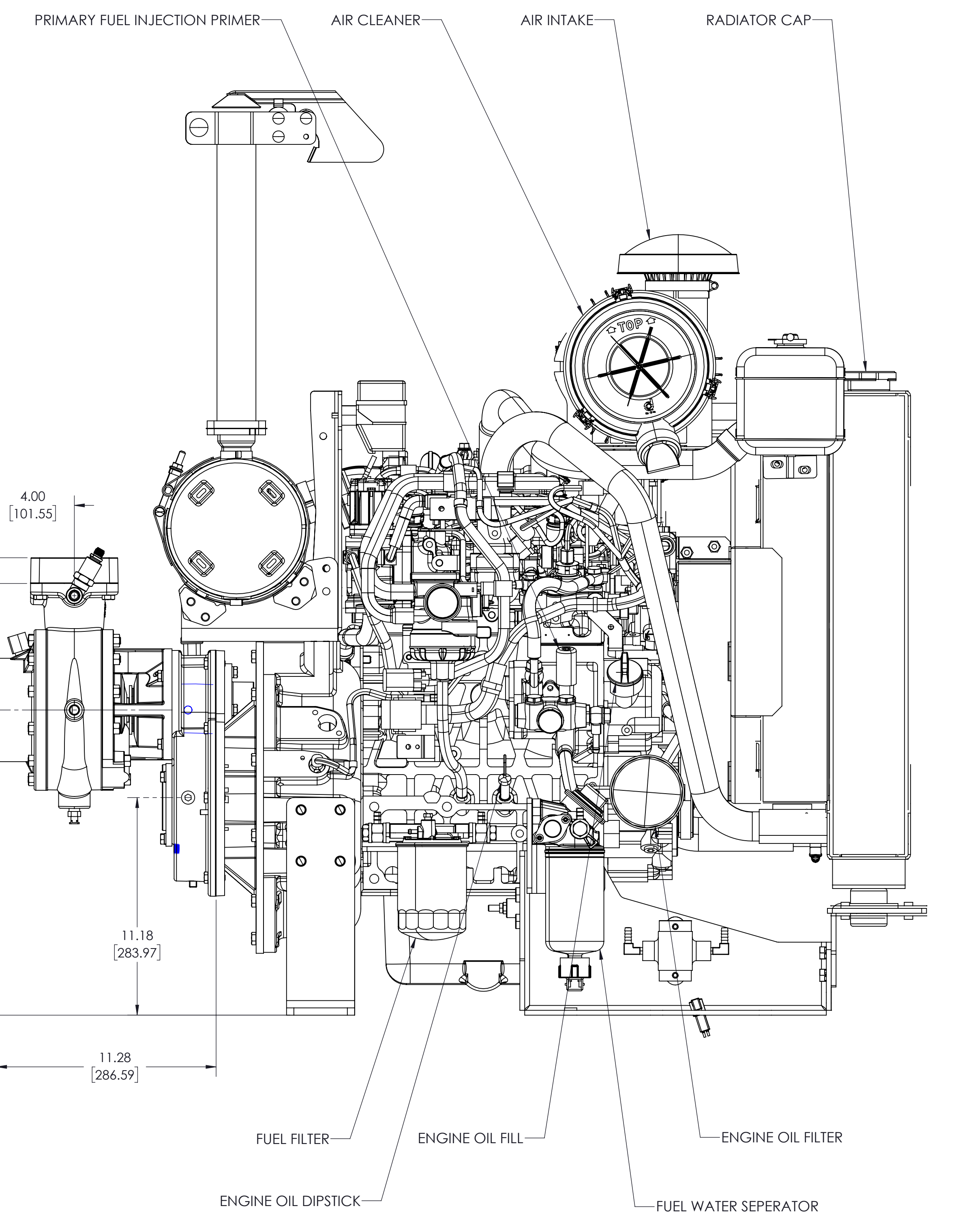
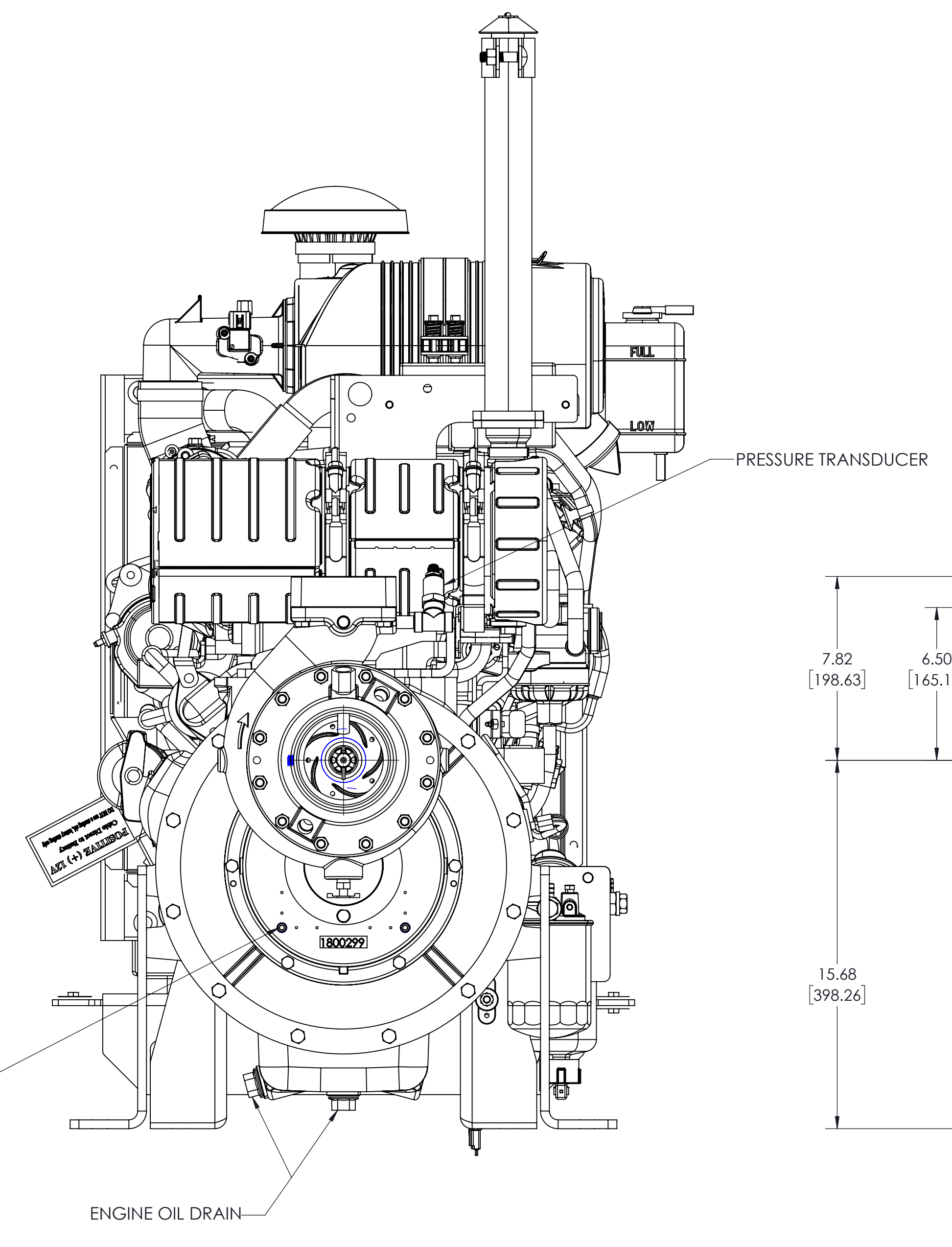
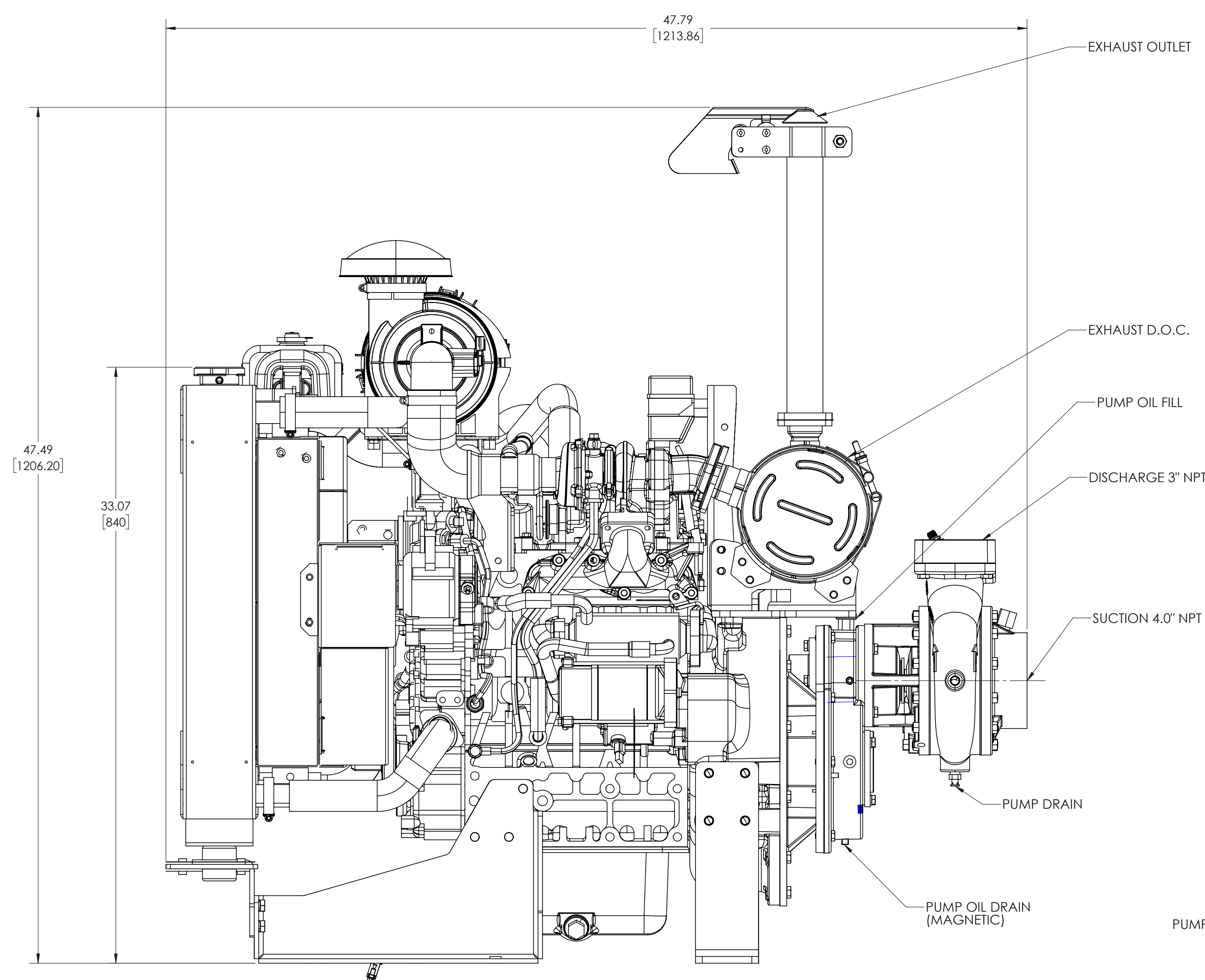

REMOVE SHARP EDGES	INCH (MILLIMETER)	BASE ANGLE PROJECTION	OLD PART NO.	TOLERANCE EXCEPT AS NOTED	MODEL	SHEET
MATERIAL DESCRIPTION	MASS		PATTERN NO.	20 0.00 ANGLES 1:1	DHD2702	1/1
THIS DESIGN IS THE PROPERTY OF W.S. DARLEY CO. - UNAUTHORIZED REPRODUCTION IS PROHIBITED.	807.79 LBS			DATE: 06/20/2018	Darley	ITASCA, IL
ALL DIMENSIONS IN INCHES UNLESS NOTED	DO NOT SCALE PRINT			SCALE: 1:4	CHIPPewa FALLS, WI	
					DHD2702	