

ADD 50% ANTIFREEZE/50% WATER HERE
HEAT EXCHANGER W/ INTEGRAL EXPANSION TANK

LARGE OIL RESERVOIR
USE HIGH QUALITY 2-CYCLE OIL
FORMULATED FOR AIR COOLED ENGINES
(NOT MARINE)

7.81

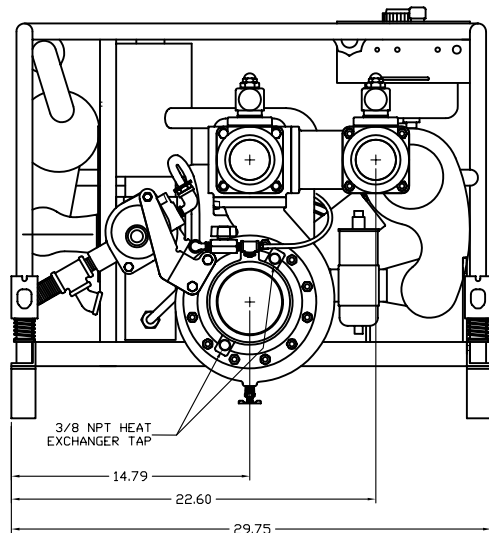

3/8 NPT HEAT EXCHANGER TAP

14.79
22.60
29.75

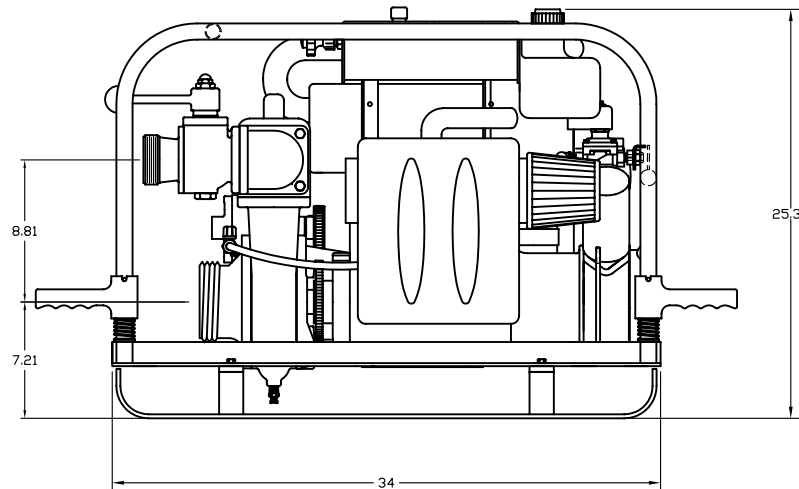

8.81

7.21

25.36

34

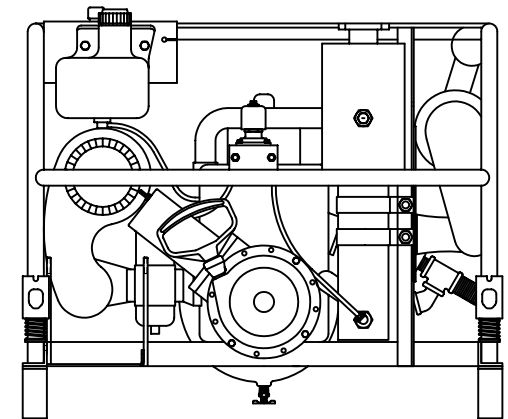

WEIGHT, DRY, WITH COMPONENTS SHOWN = 225 POUNDS

MATERIAL:

THIS DESIGN IS THE PROPERTY OF
W.S. DARLEY AND CO. - UNAUTHORIZED
REPRODUCTION IS PROHIBITED

ALL DIMENSIONS IN
INCHES UNLESS NOTED

DO NOT SCALE PRINT

OLD PART NO.	PART NO.	DATE	CHANGE

W.S. DARLEY & CO.
 MELROSE PARK, IL - SHIPPERS FALLS, WI
 HE64RP PORTABLE PUMP
 DIMENSIONAL DRAWING

PATTERN NO. 

DWN MCR DATE: 8-21-91
 CHKD DATE: 8-21-91
 TRCD: GZ 6/97 SCALE: 1/4

DHD0501