

| REVISIONS | | | | |
|-----------|------|-------------|------|------------------|
| ZONE | REV. | DESCRIPTION | DATE | CHG NO. APPROVED |

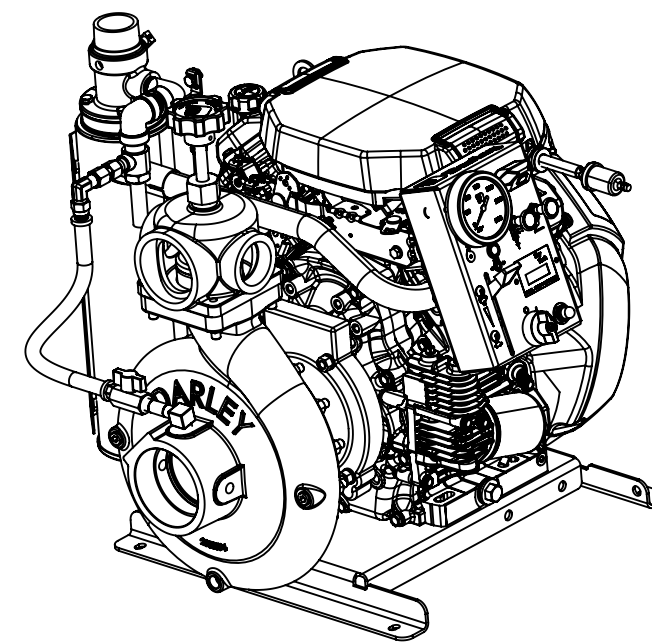
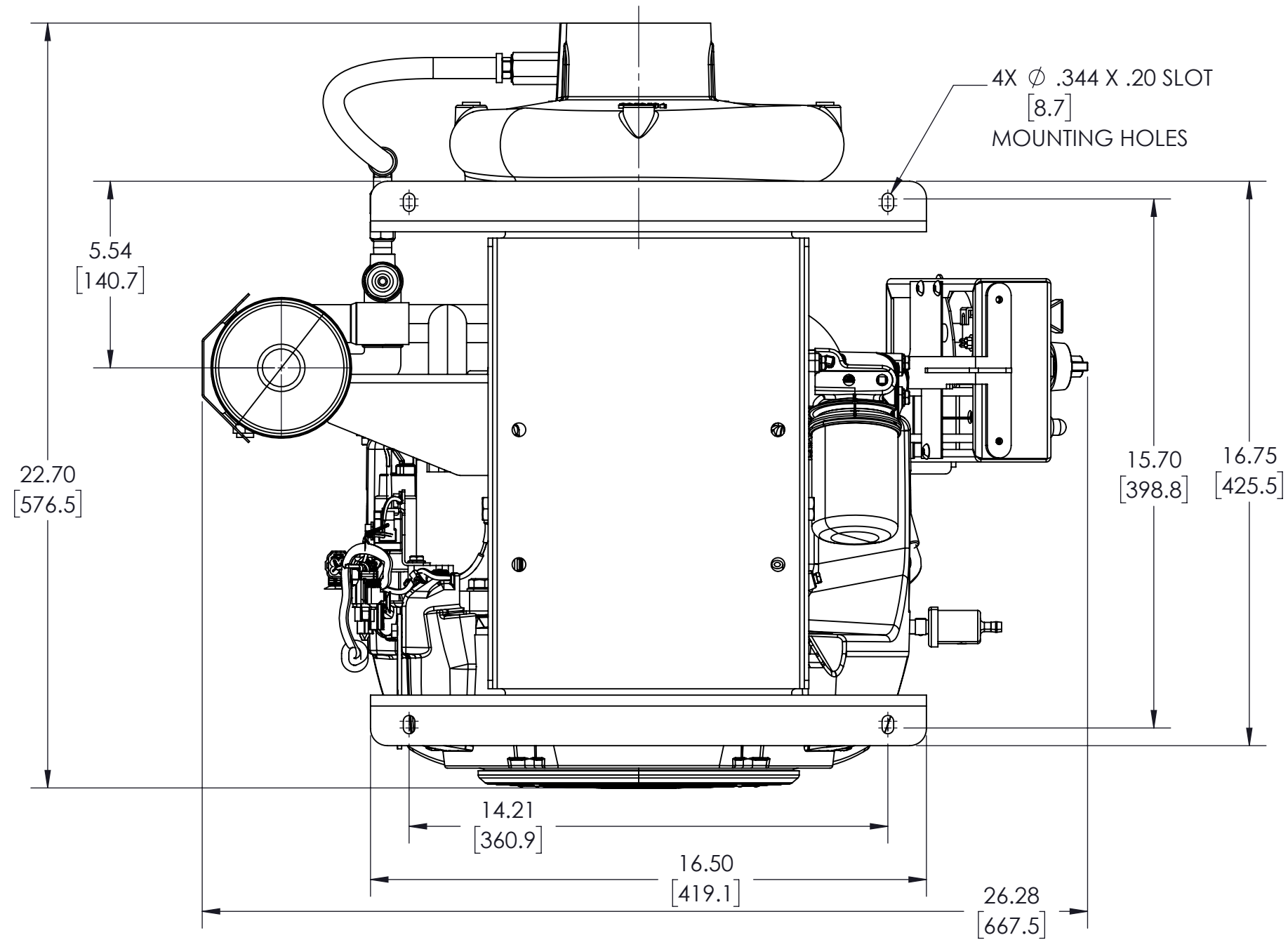
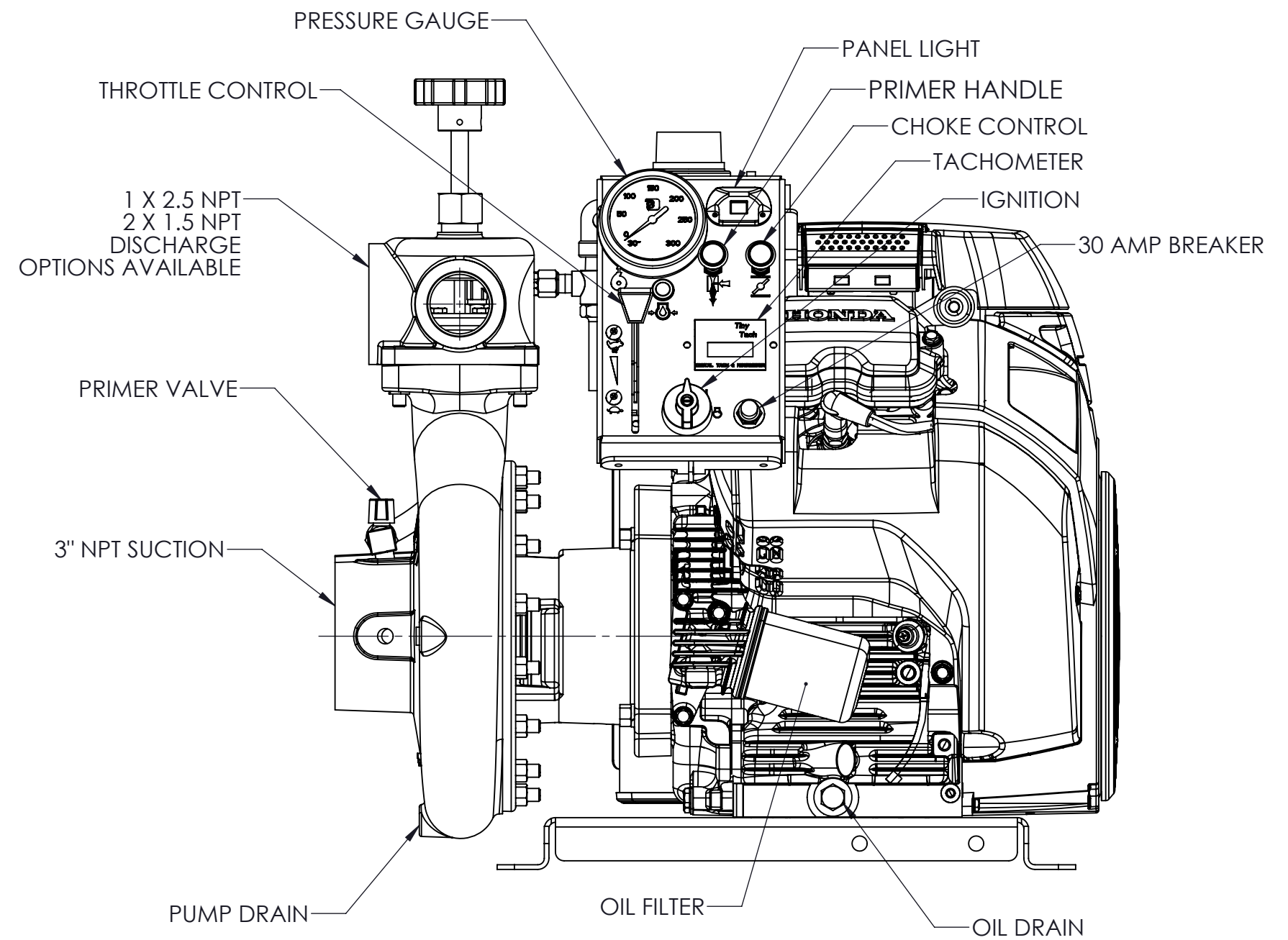
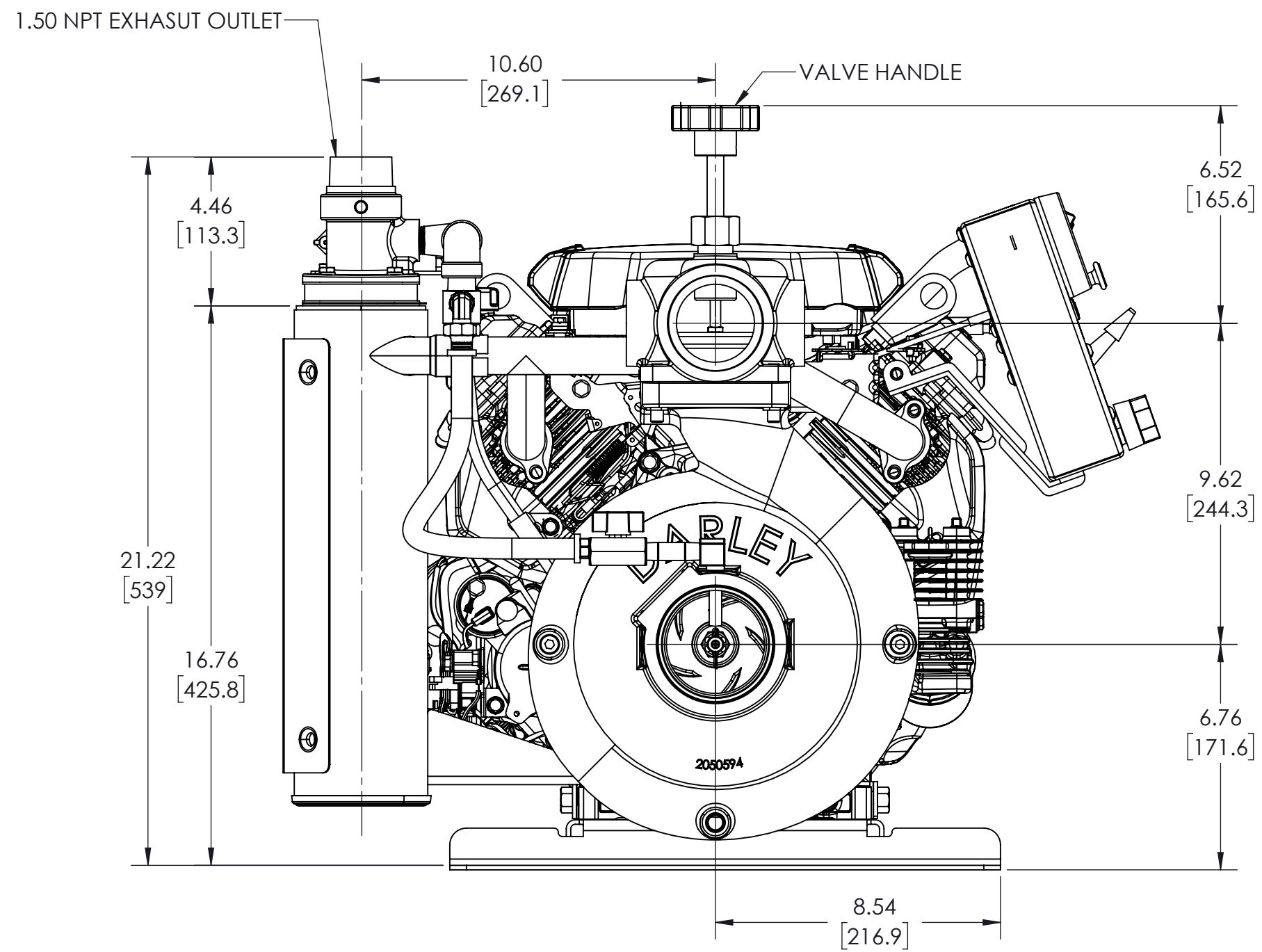

ASSEMBLIES SHOWN:
 BASE - 1681803
 PLATE SERIAL NO - 1963108
 BRACKET - 4007202
 ENGINE - 4216463
 PRIMER - AP01414
 DISCHARGE HEAD - HA00308
 EXHAUST - KE01501
 PUMP - PB00136
 SPARK ARRESTOR - KE00502
 P65 LABEL - 1978321
 CONTROL PANEL - AC01125
 3 GAL FUEL TANK (SHIPPED LOOSE) - KE00129

| | | | | | | |
|--|--|---------------------------|--------------|-------------------------------------|--|--------------|
| REMOVE SHARP EDGES MATERIAL DESCRIPTION THIS DESIGN IS THE PROPERTY OF WS. DARLEY CO. - UNAUTHORIZED REPRODUCTION IS PROHIBITED | INCH [MILLIMETER] | THIRD ANGLE PROJECTION | OLD PART NO. | TOLERANCE EXCEPT AS NOTED | MODEL DBD0709 | SHEET 1/1 |
| | MASS 184.28 LBS | MATERIAL NO. | PATTERN NO. | .00 ±.03 .000 ±.010 ANGLES ±1 | Darley ITASCA, IL CHIPPEWA FALLS, WI | |
| | ALL DIMENSIONS IN INCHES UNLESS NOTED | DO NOT SCALE PRINT | | DRWN SMS | DWG - 1.5AGE21H EXHAUST PRIMER | |
| | | | | CKHD TED | DATE: 3/25/2020 | DBD0709 |
| | | | | TRCD | SCALE: 1:8 | |