

ITEM NO.	File Name	Darley Item Description (Line 1)	QTY.
1	4229902	ENGINE - KUBOTA, D1803T	1
2	TE00458	TRANS - AGE, SAE 4 HOUSING	1
3	2700704	GEAR - PINION, AG, 14DP, 20PA	1
4	2700604	GEAR - DRIVE, AG, 14DP, 20*PA	1
5	PA00633_9OCLOCK	PUMP - 2.5AG, MECH SEAL	1
6	YF02937	ASSY - FLANGE, 2.5" WELD	1
7	2800803	HEAD - SUCT, A	1
8	1080831	ELBOW - PIPE, ST, 0.25, 90 DEG	1

REVISIONS					
ZONE	REV.	DESCRIPTION	DATE	CHG NO.	APPROVED

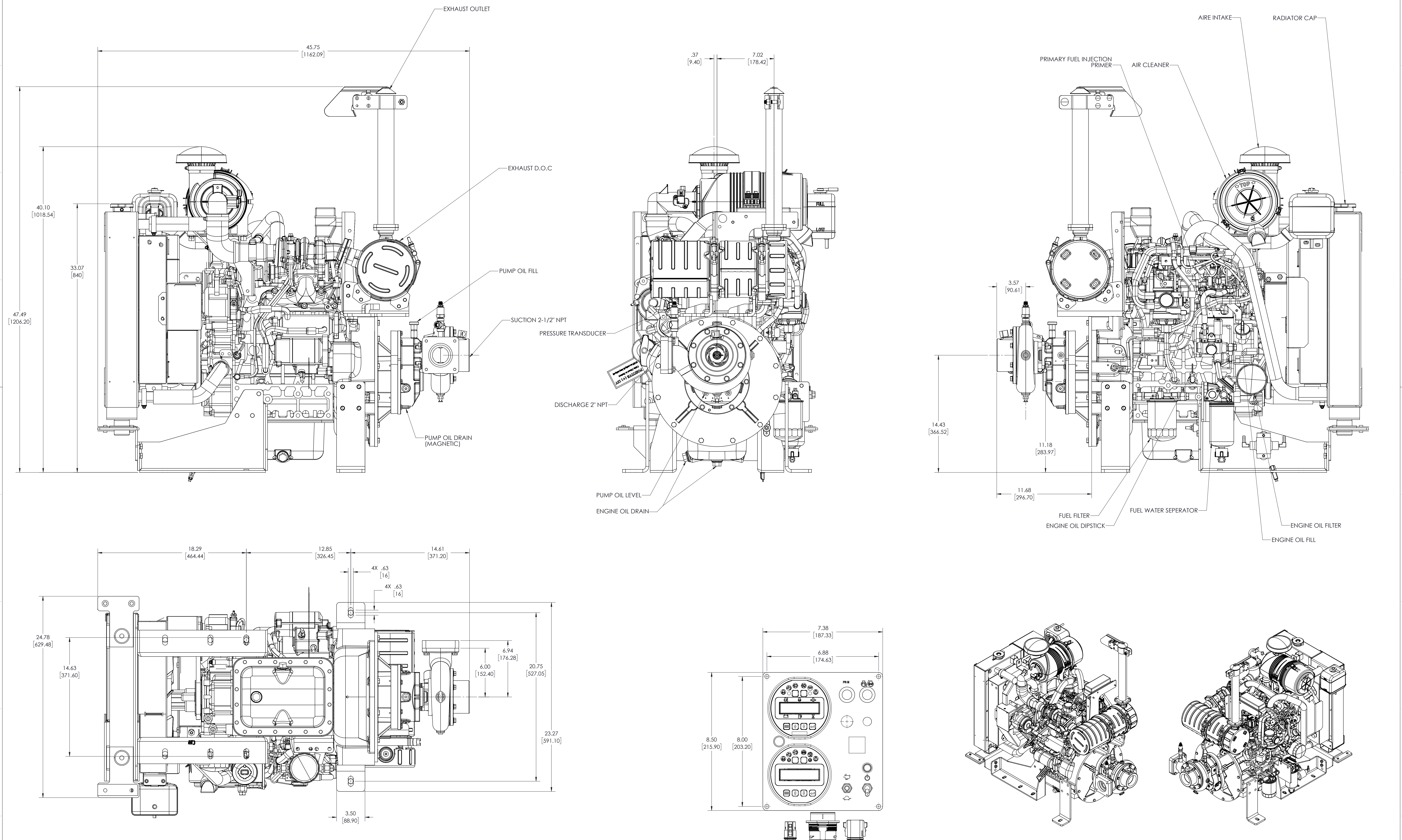

REMOVE SHARP EDGES	INCH (MILLIMETER)	OLD PART NO.	TOLERANCE EXCEPT AS NOTED	MODEL	SHEET
THIS DESIGN IS THE PROPERTY OF W.S. DARLEY CO. - UNAUTHORIZED REPRODUCTION IS PROHIBITED.	.0010 INCH	PATTERN NO.	AS NOTED	DAD3208	1/1
	ALL DIMENSIONS IN INCHES UNLESS NOTED		20 1/8	Darley ITASCA, IL	
			ANGLES: 1:1	CHIPPewa FALLS, WI	
			3/16	DWG - 2.5AG/48K - TRF 4	
			CRHD SLS	SAE #4 ENGINE ADAPTER, 9 OCLOCK	
			TRCD	DATE: 1/10/2022	
				SCALE: 1:4	DAD3208