

ITEM NO.	File Name	Darley Item Description (Line 1)	QTY.
1	4229902	ENGINE - KUBOTA, D1803T	1
2	TE00458	TRANS - AGE, SAE 4 HOUSING	1
3	2700704	GEAR - PINION, AG, 14DP, 20PA	1
4	2700604	GEAR - DRIVE, AG, 14DP, 20*PA	1
5	PA00633_3OCLOCK	PUMP - 2.5AG, MECH SEAL	1
6	YF02937	ASSY - FLANGE, 2.5" WELD	1
7	2800803	HEAD - SUCT, A	1
8	1080831	ELBOW - PIPE, ST, 0.25, 90 DEG	1

REVISIONS					
ZONE	REV.	DESCRIPTION	DATE	CHG NO.	APPROVED

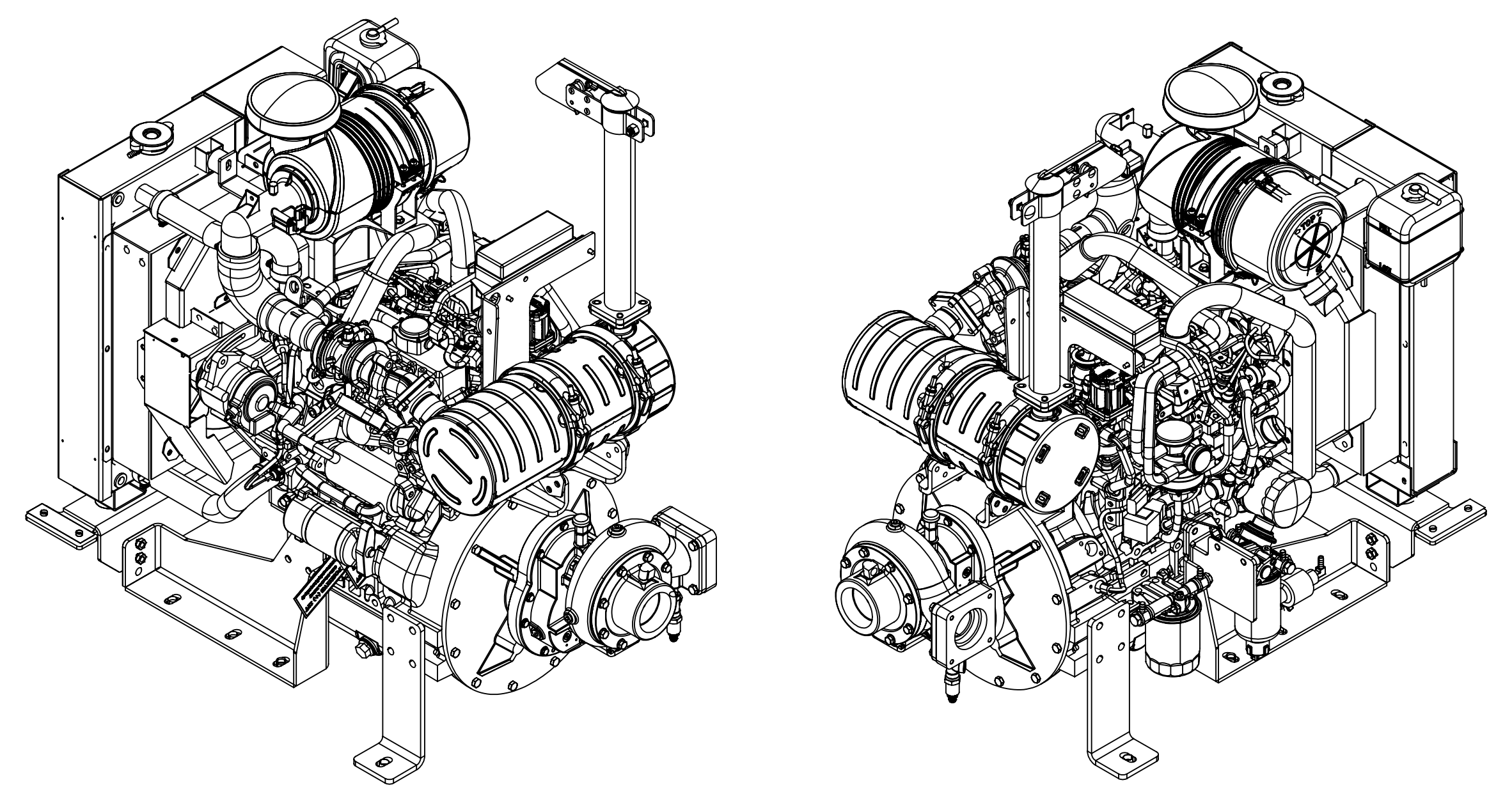
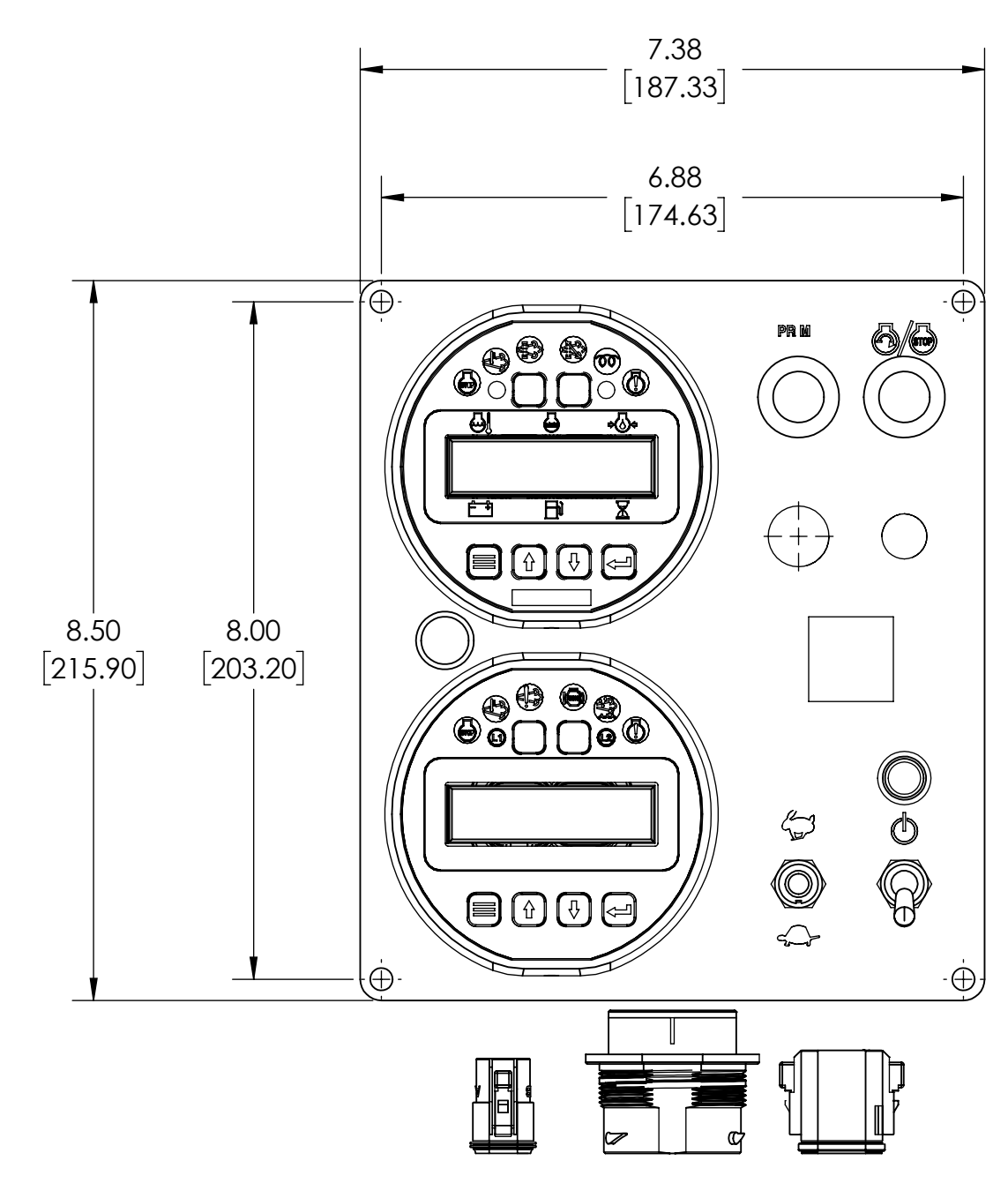
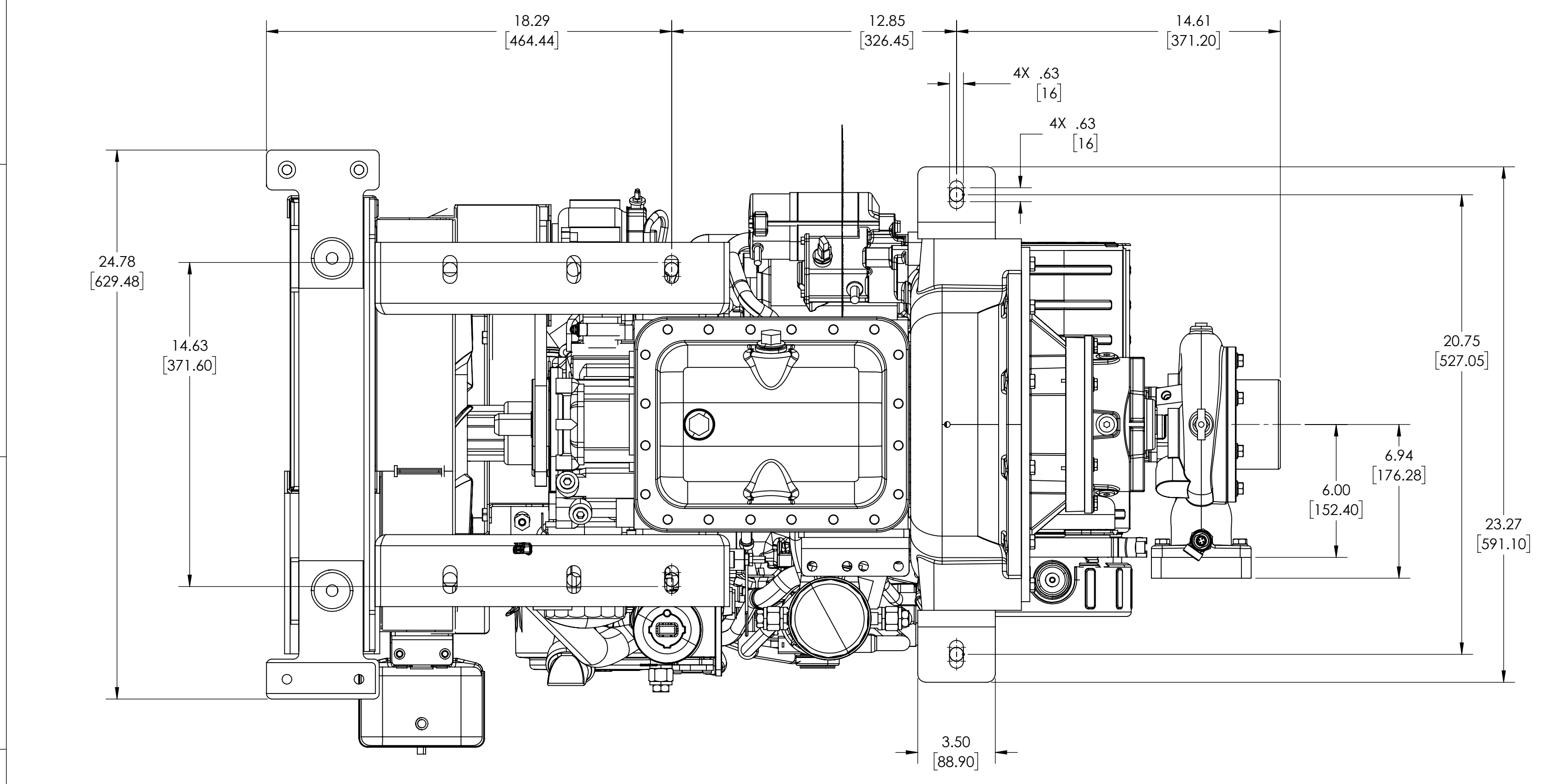
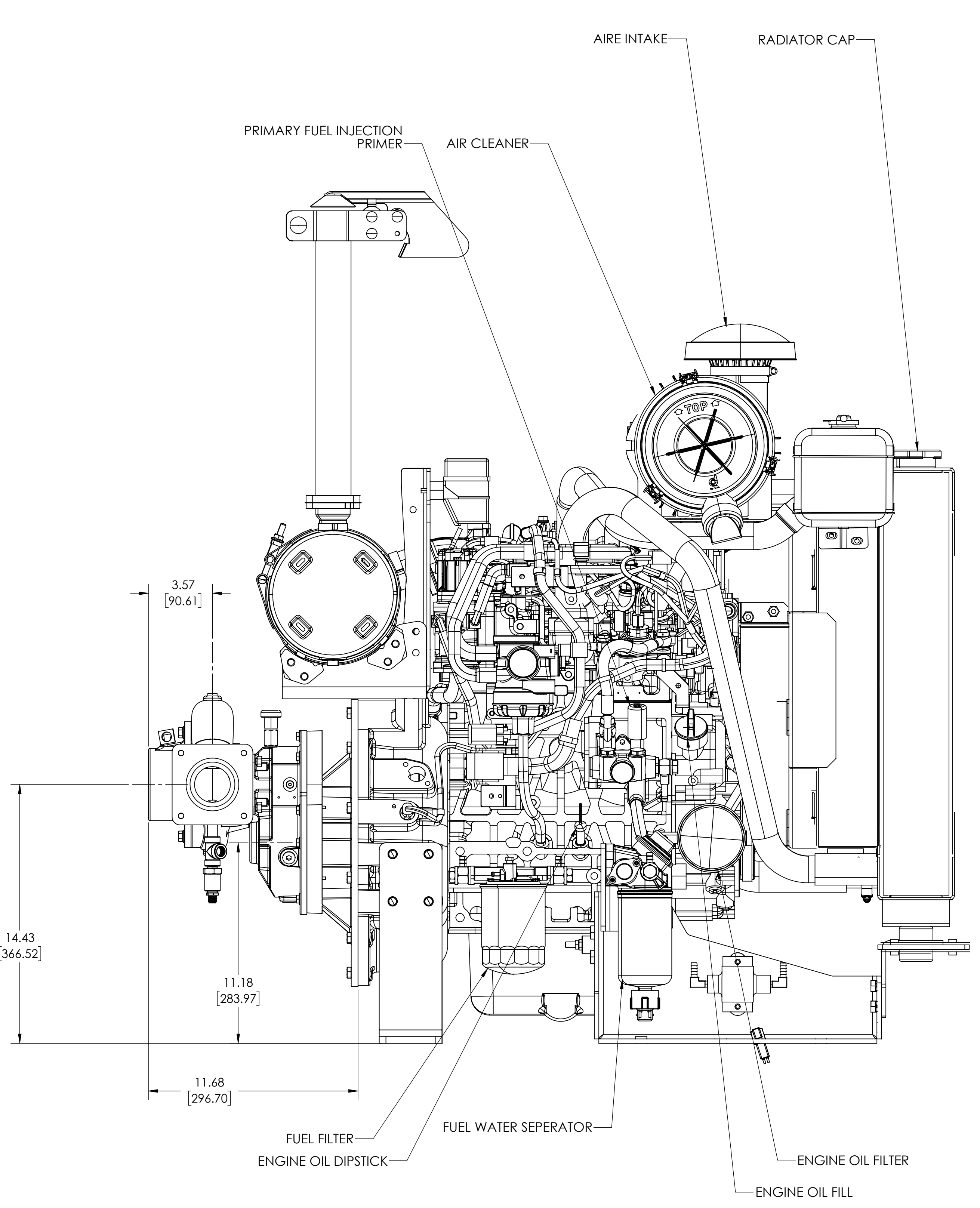
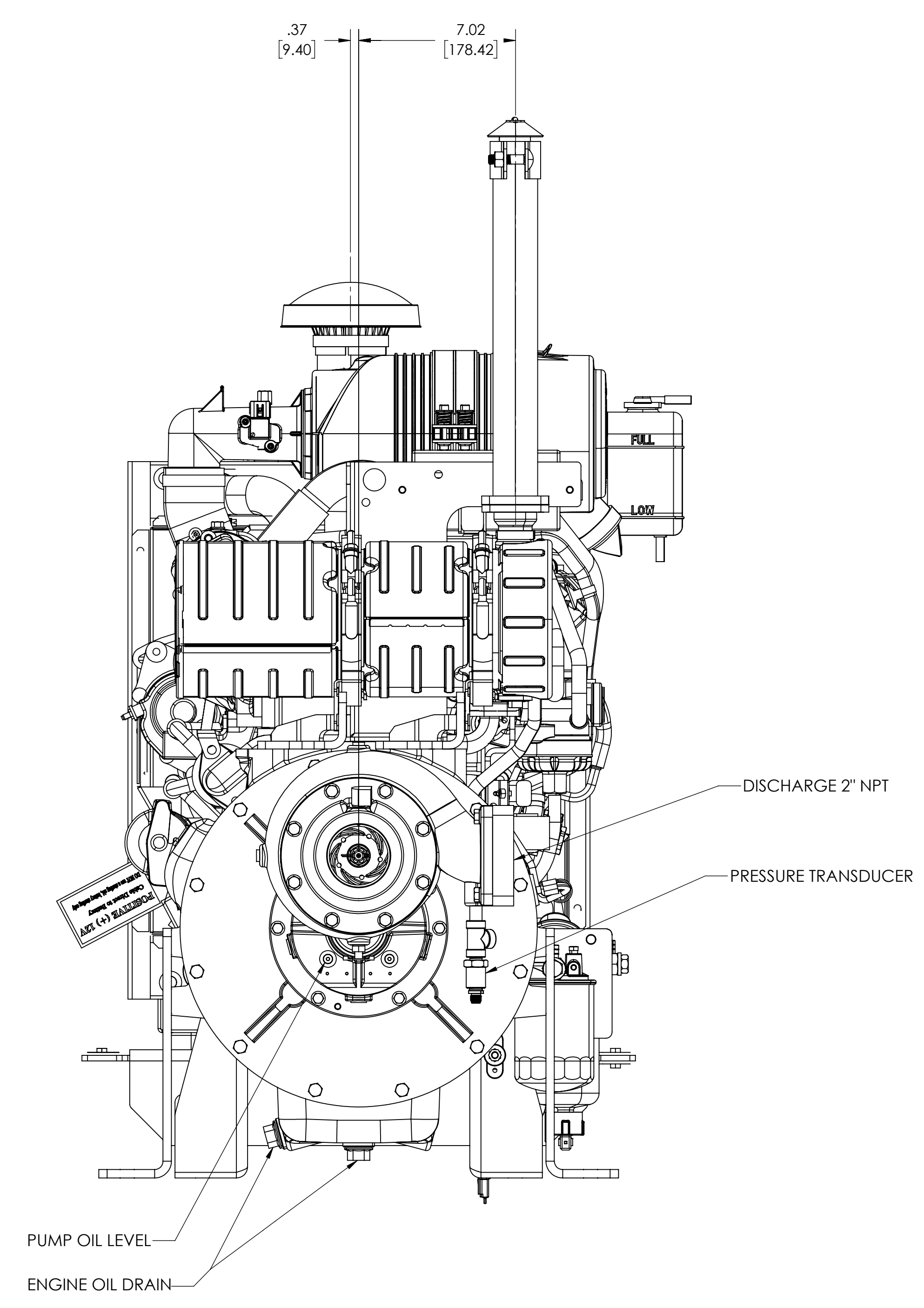
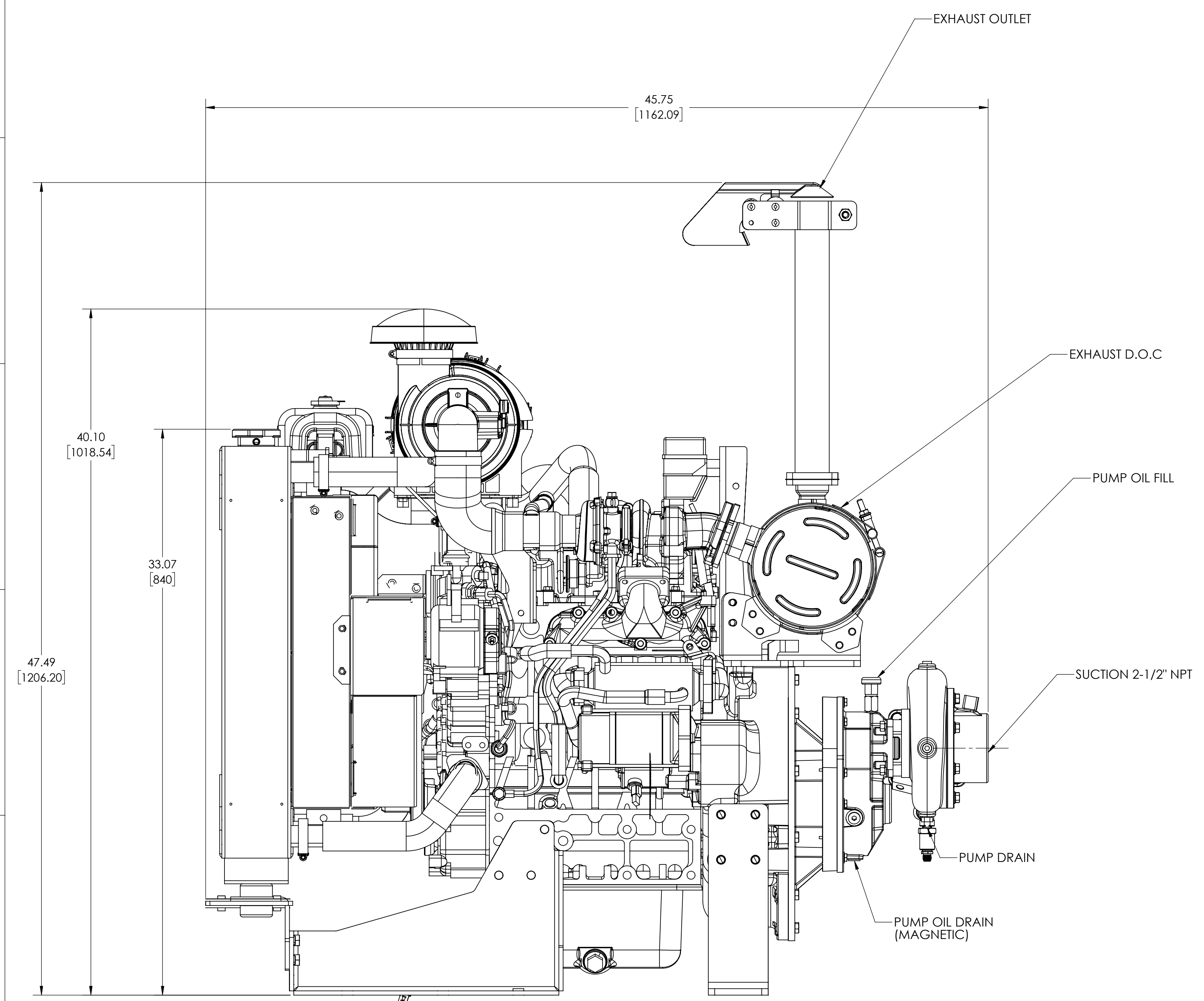

REMOVE SHARP EDGES	INCH [MILLIMETER]	BASE ANGLE PROJECTION	OLD PART NO.	TOLERANCE EXCEPT AS NOTED	MODEL	SHEET
THIS DESIGN IS THE PROPERTY OF W.S. SAMLEY CO. - UNAUTHORIZED REPRODUCTION IS PROHIBITED.	.0015" [0.038]	AS SHOWN	PATTERN NO.	AS SHOWN	DAD3206	1/1
	MASS			DAE #4 ENGINE ADAPTER, 3 OCLOCK	Darley ITASCA, IL	
	757.40 LBS			DATE: 1/10/2022	CHIPPEWA FALLS, WI	
	ALL DIMENSIONS BY INCHES UNLESS NOTED			SCALE: 1:4	DAD3206	