

ITEM NO.	File Name	Darley Item Description (Line 1)	QTY.
1	4229902	ENGINE - KUBOTA, D1803T	1
2	TE00458	TRANS - AGE, SAE 4 HOUSING	1
3	2700704	GEAR - PINION, AG, 14DP, 20PA	1
4	2700604	GEAR - DRIVE, AG, 14DP, 20*PA	1
5	PA00633	PUMP - 2.5AG, MECH SEAL	1
6	YF02937	ASSY - FLANGE, 2.5" WELD	1
7	2800803	HEAD - SUCT, A	1
8	1080831	ELBOW - PIPE, ST, 0.25, 90 DEG	1

REVISIONS					
ZONE	REV.	DESCRIPTION	DATE	CHG NO.	APPROVED
A		UPDATED ENGINE 3D MODEL	8/14/2019	12409	SMS

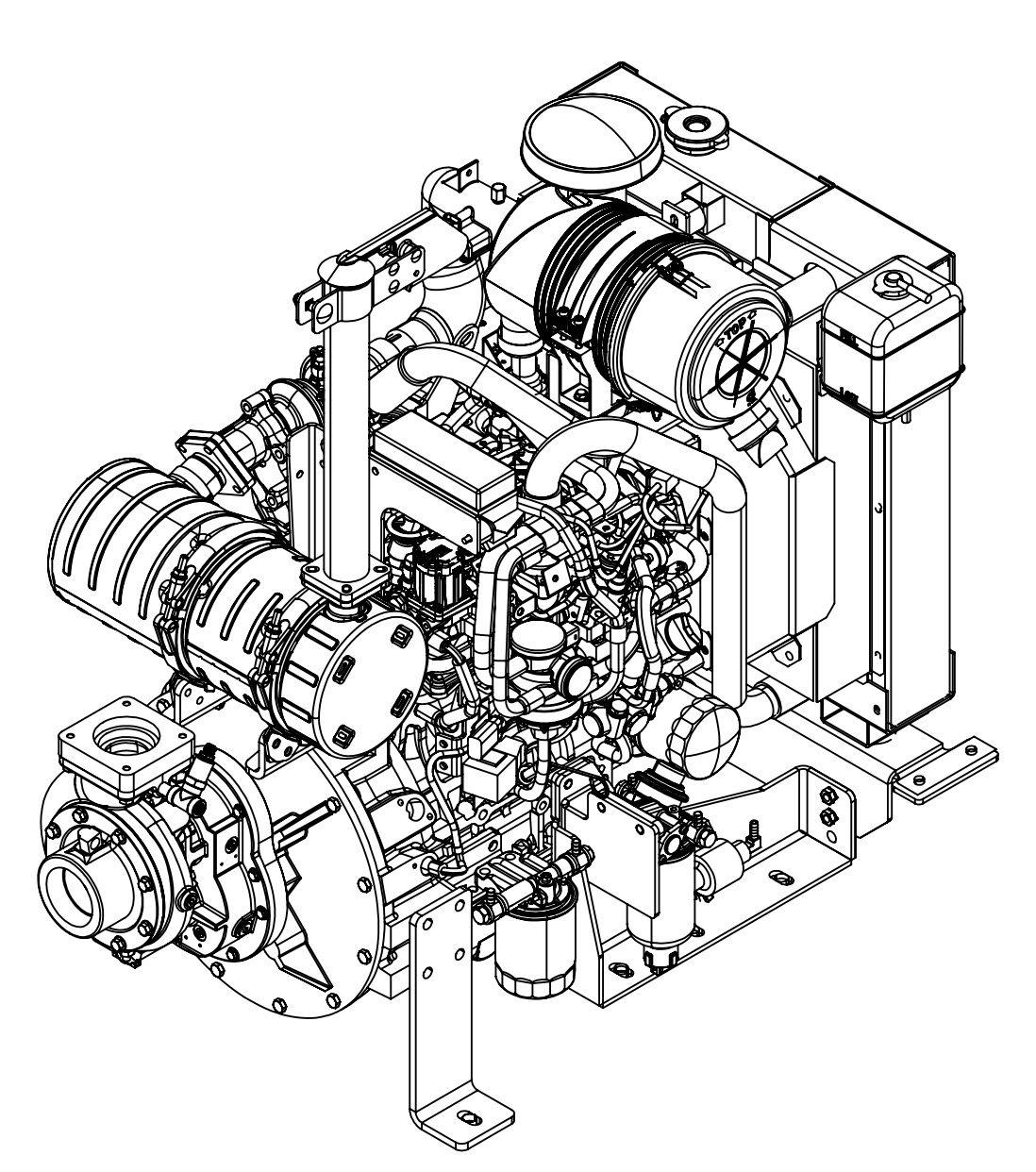
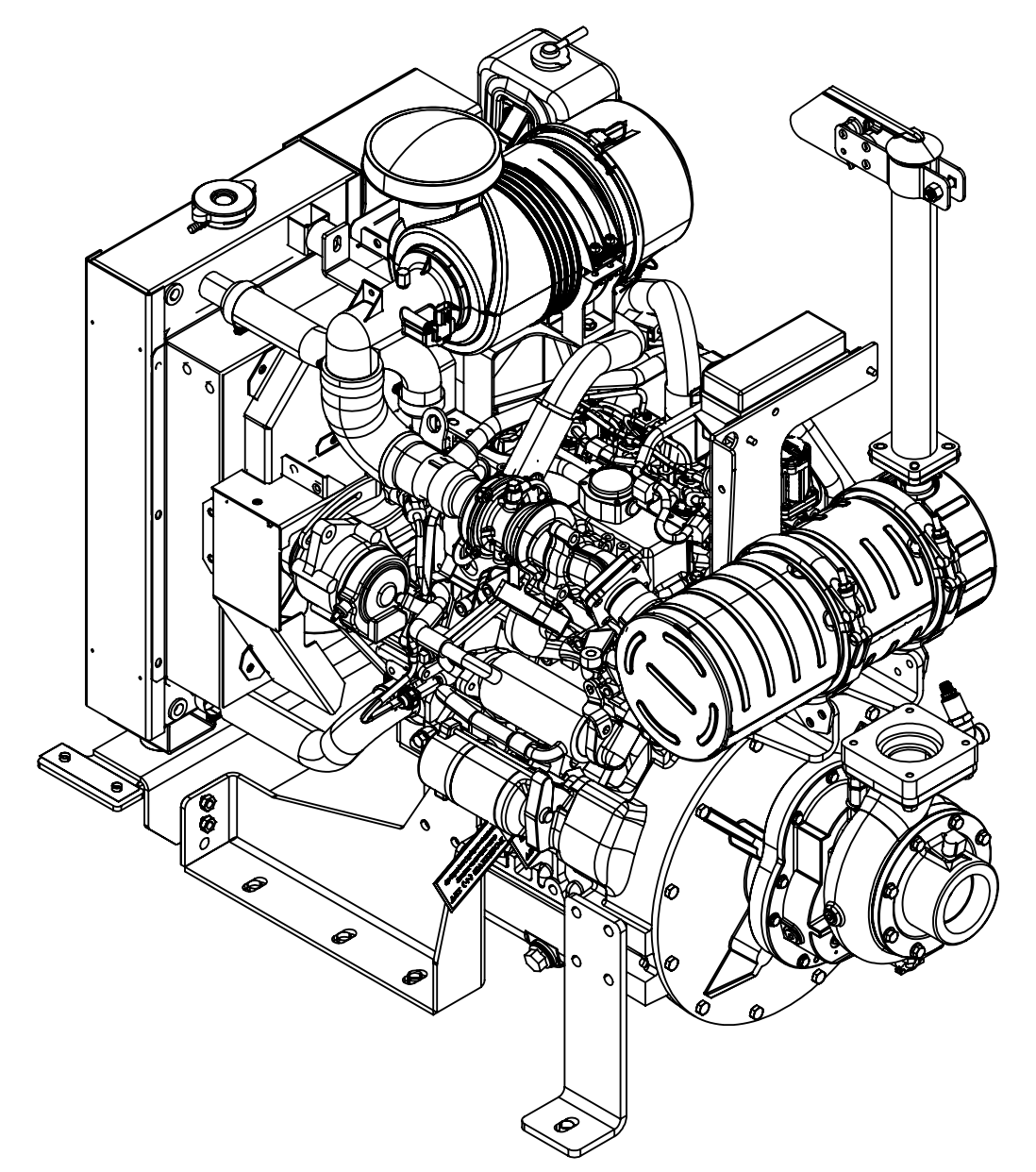
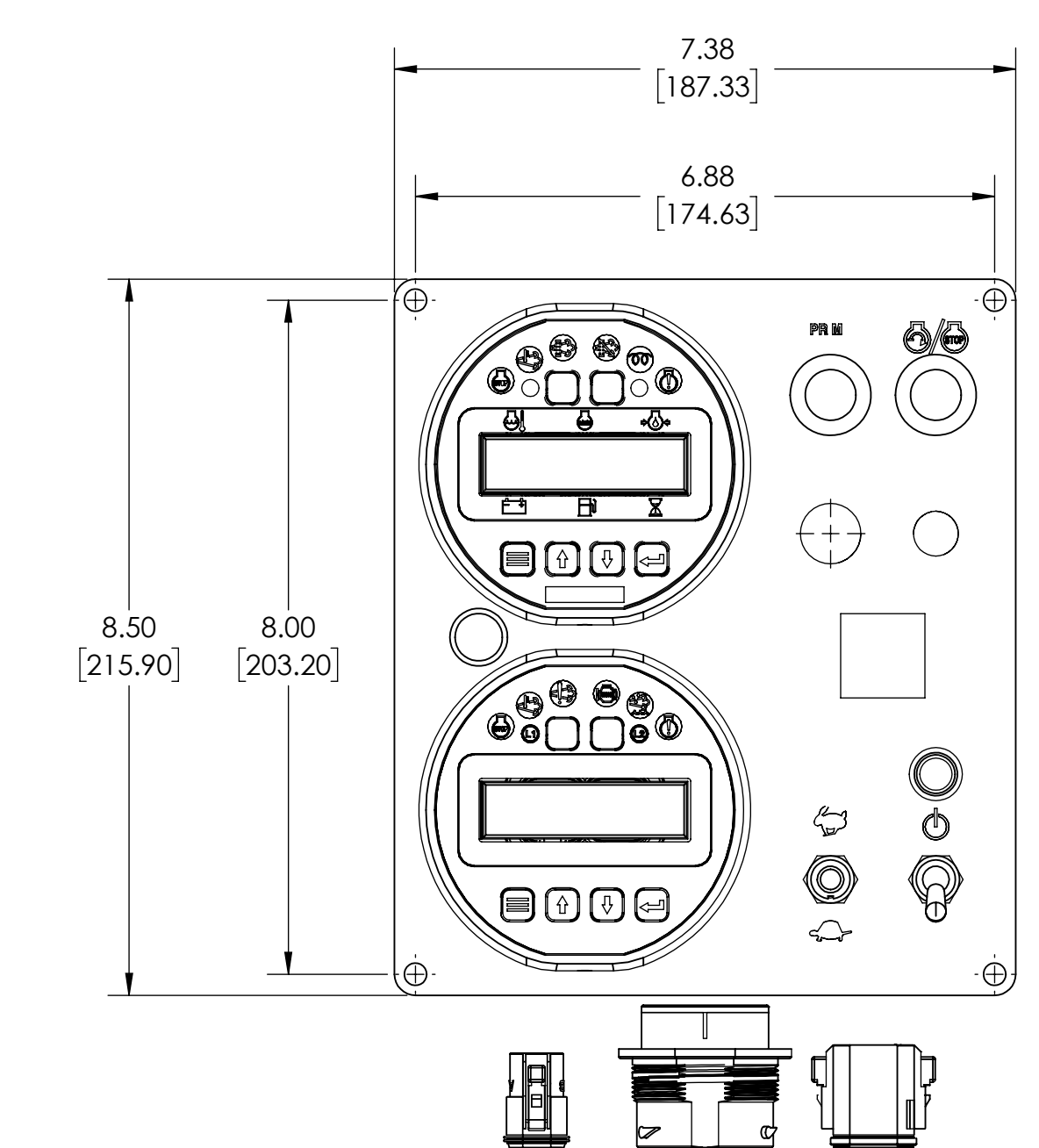
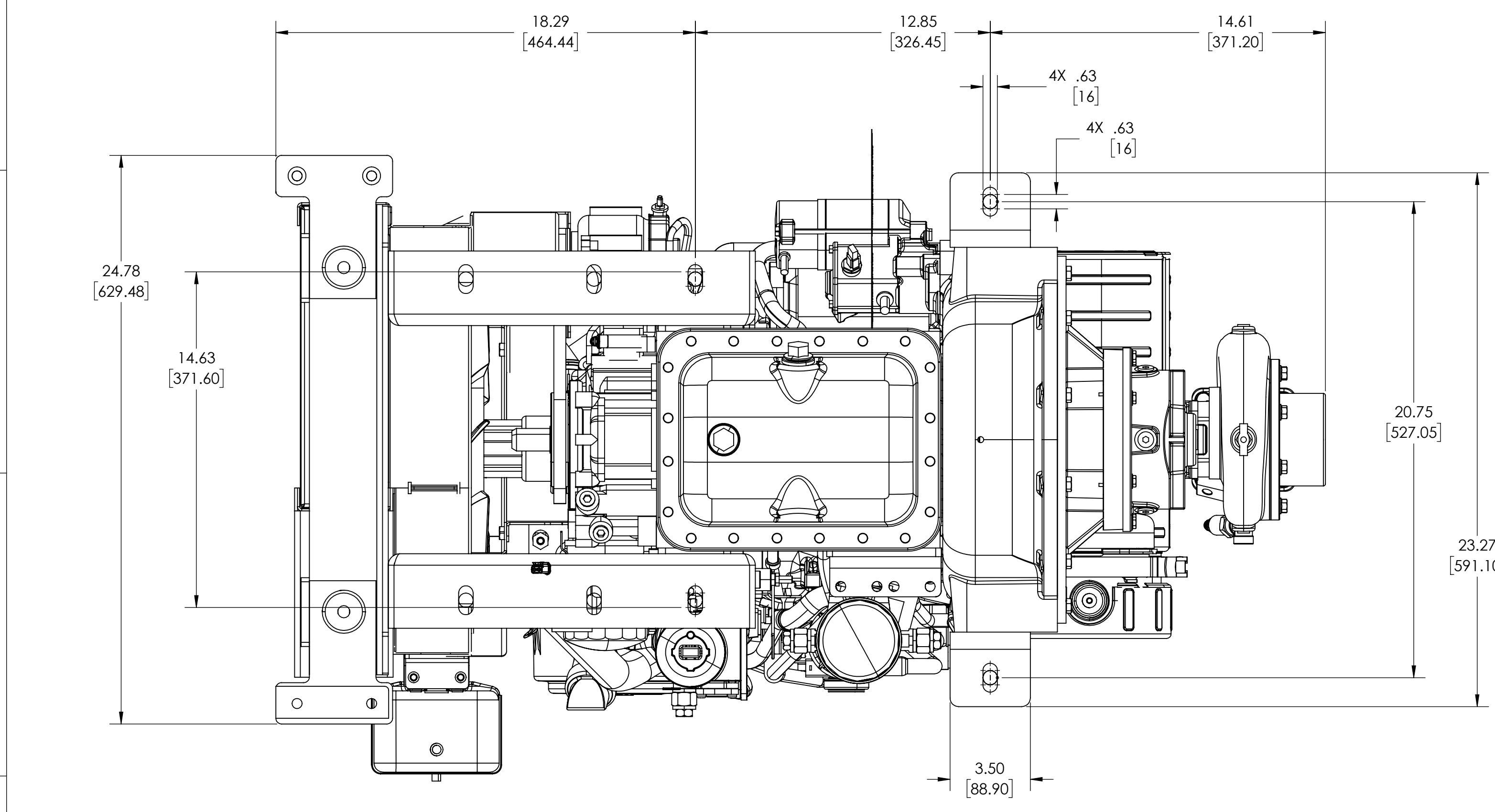
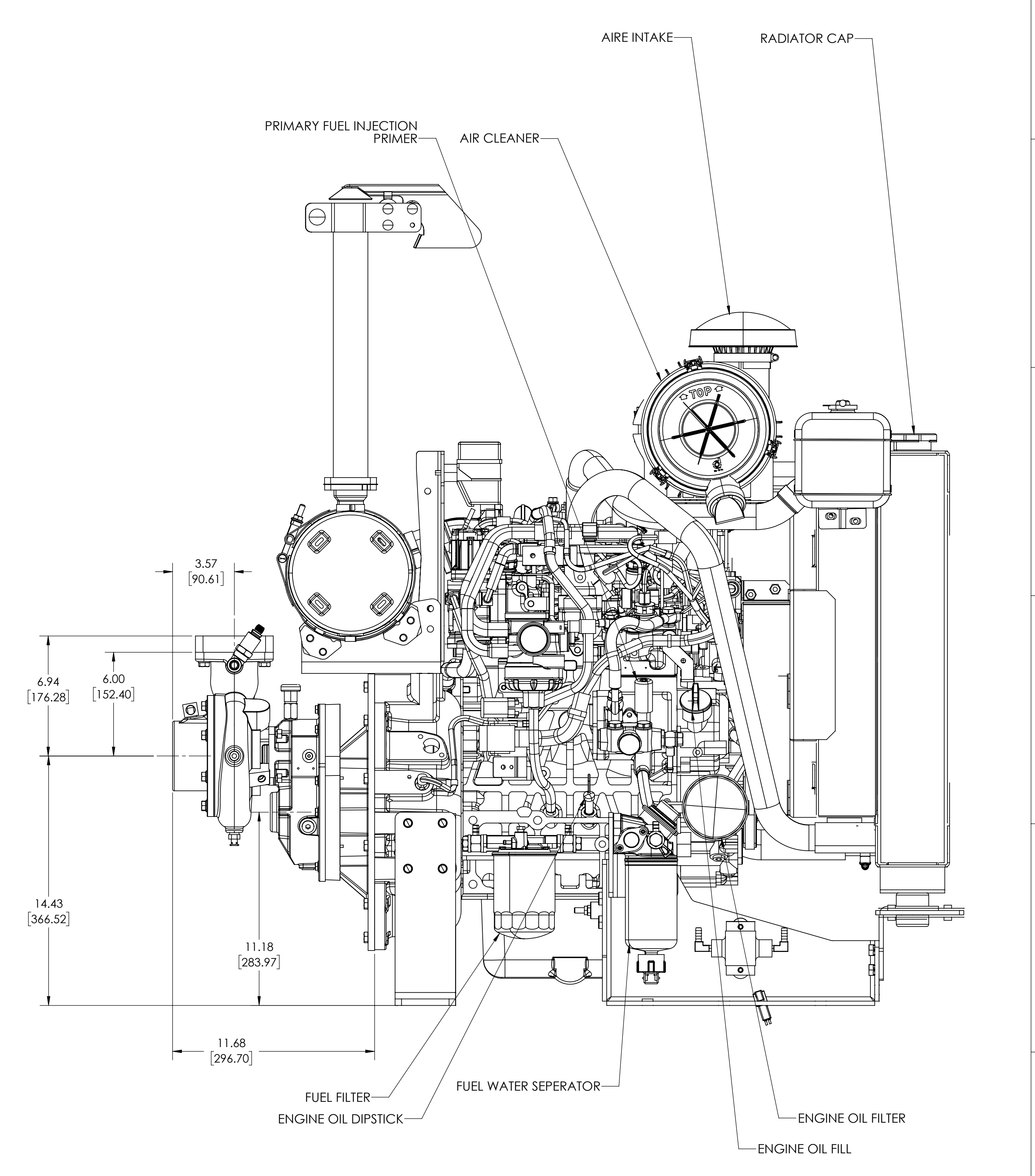
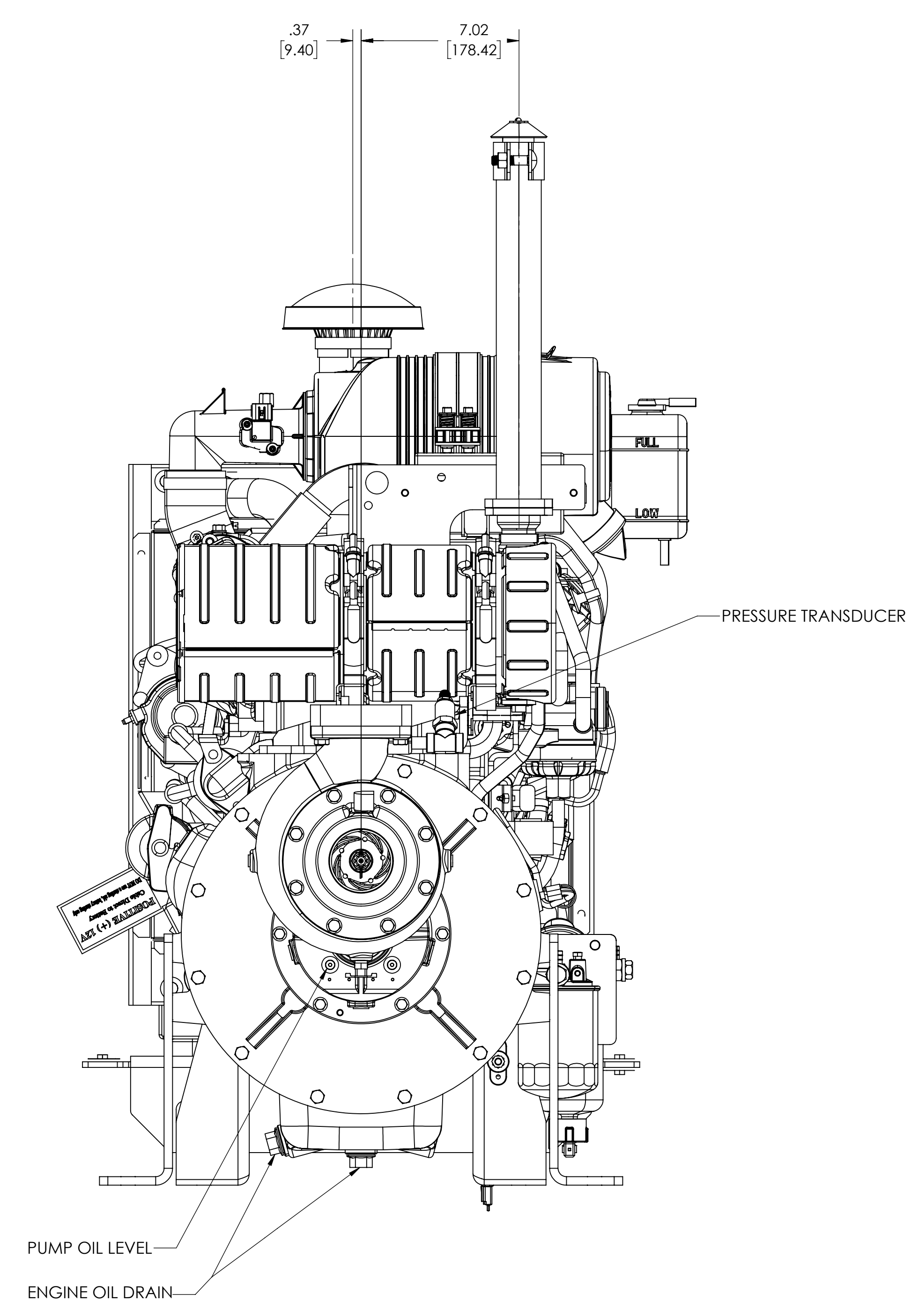
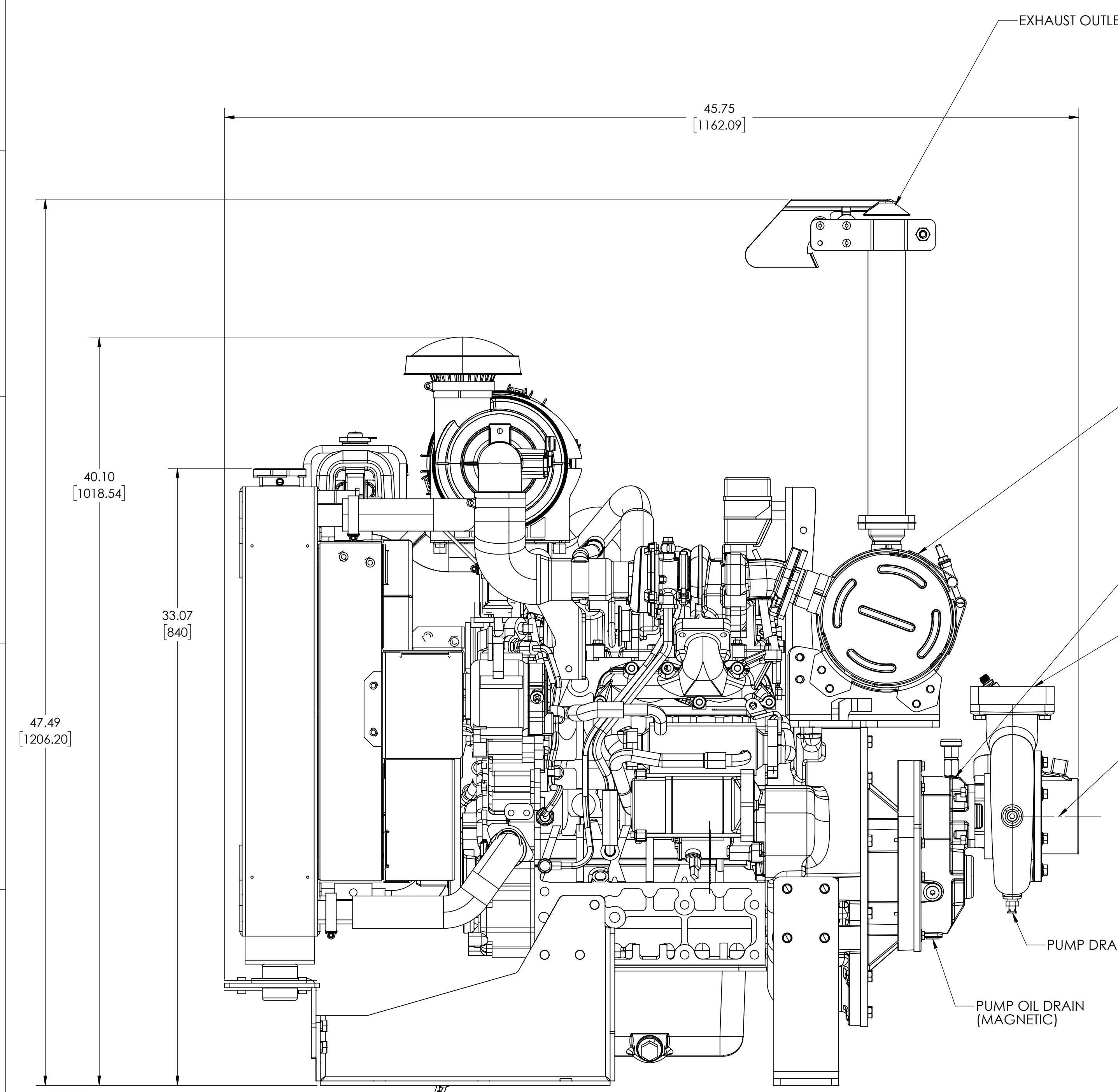

REMOVE SHARP EDGES	INCH [MILLIMETER]	MODEL	SHEET
MASS	757.48 LBS	DAD301	1/1
THIS DESIGN IS THE PROPERTY OF W.S. SAMLEY CO. - UNAUTHORIZED REPRODUCTION IS PROHIBITED.	ALL DIMENSIONS IN INCHES UNLESS NOTED	Darley	ITASCA, IL CHIPPENAW FALLS, WI
DO NOT SCALE PRINT	SCALE: 1:4	DAD3201	