

BOTTOM VIEW

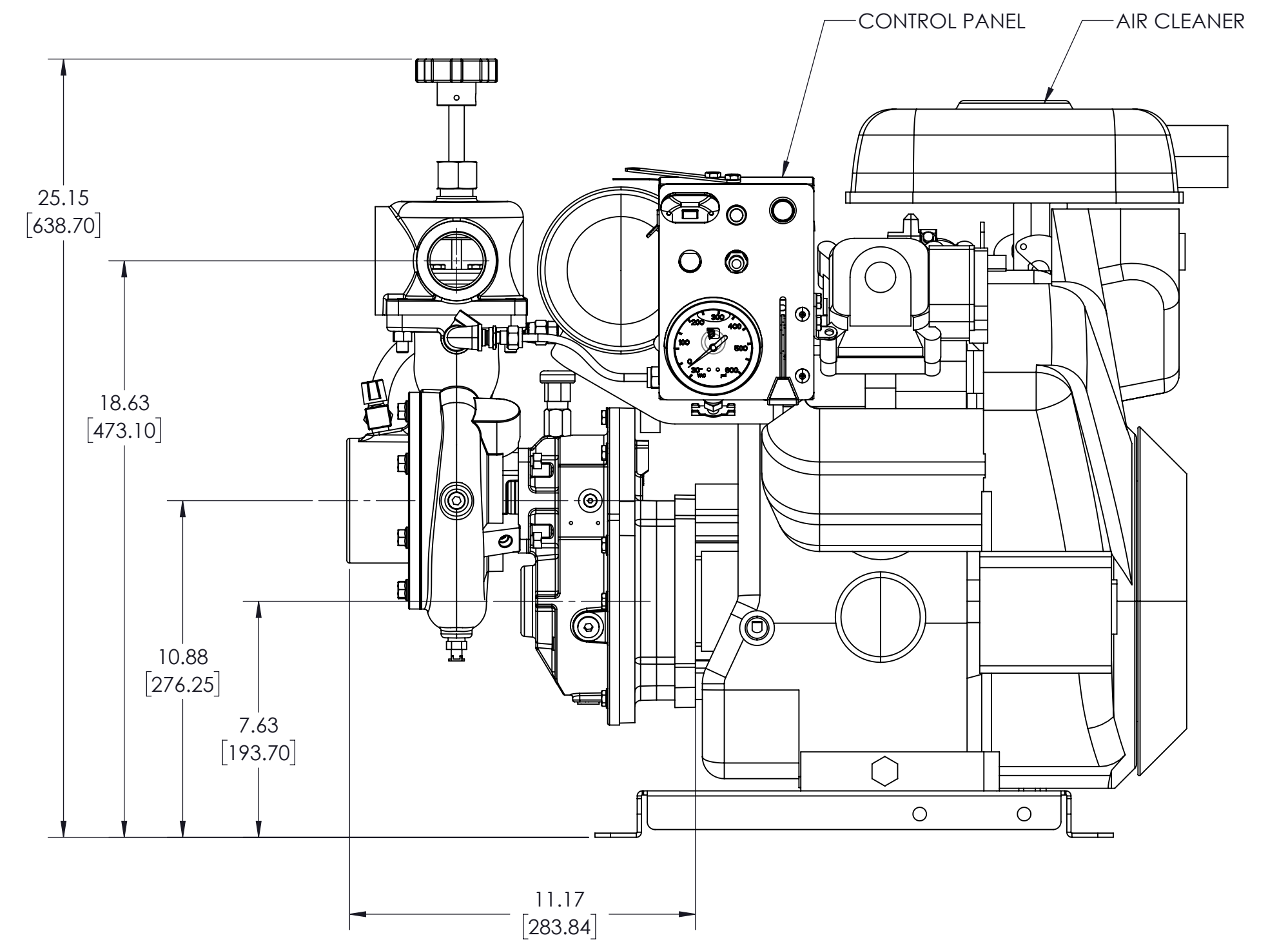

ASSEMBLY SHOWN IS FP00258

REMOVE SHARP EDGES		INCH [MILLIMETER]		THIRD ANGLE PROJECTION		MODEL DAD3009		SHEET 1/1	
MATERIAL DESCRIPTION		MASS		MATERIAL NO.		PATTERN NO.		OLD PART NO.	
187.92 LBS		187.92 LBS						TOLERANCE EXCEPT AS NOTED .00 ±.03 .000 ±.010 ANGLES ±1	
THIS DESIGN IS THE PROPERTY OF WS. DARLEY CO. - UNAUTHORIZED REPRODUCTION IS PROHIBITED		ALL DIMENSIONS IN INCHES UNLESS NOTED		DO NOT SCALE PRINT		DRWN SMS		DATE: 01/10/2019	
						CKHD CLH		SCALE: 1:4	
						TRCD		DWG- 2.SAGE 37V (4200521 )	
								DIMENSIONAL	
								DAD3009	

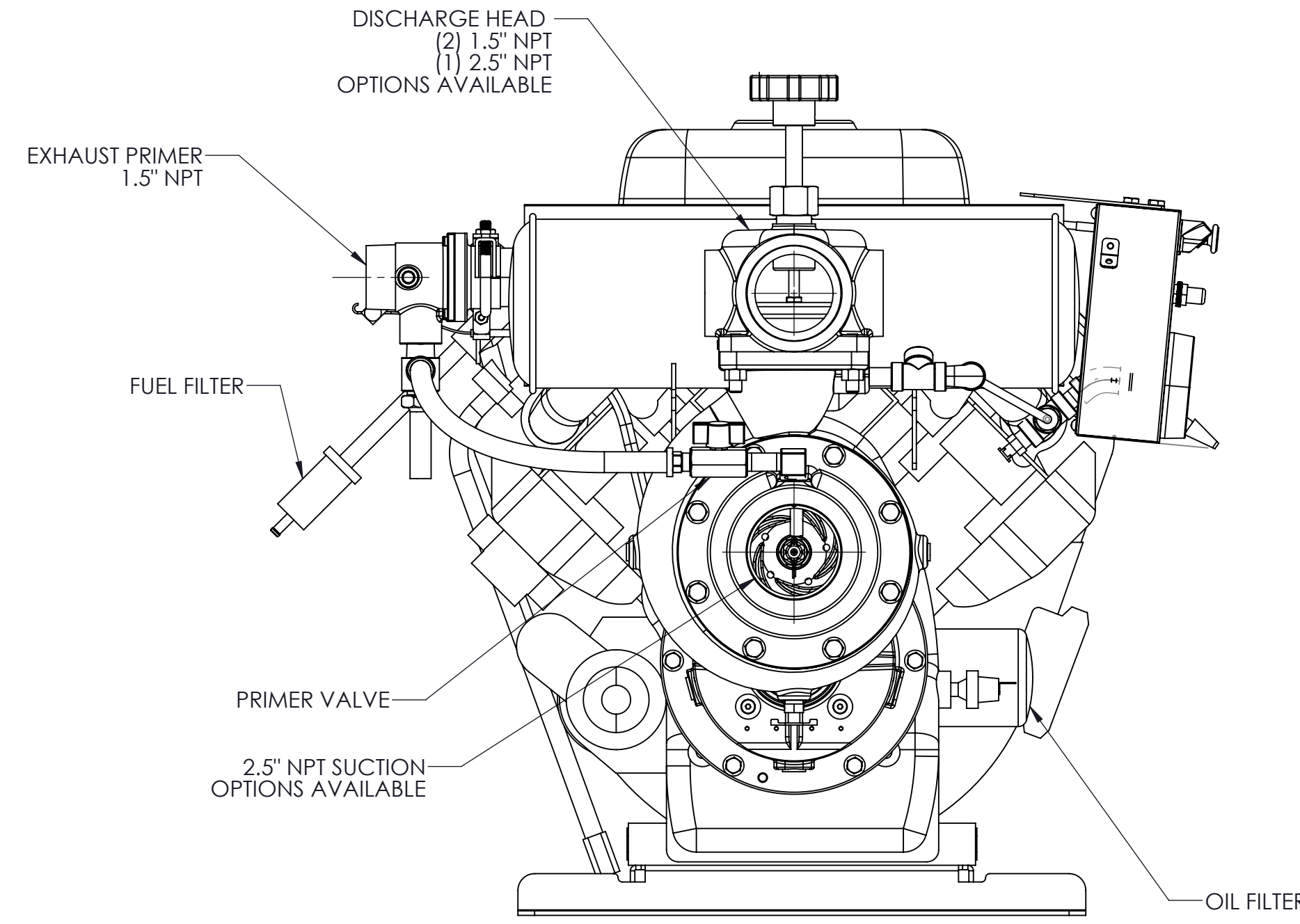
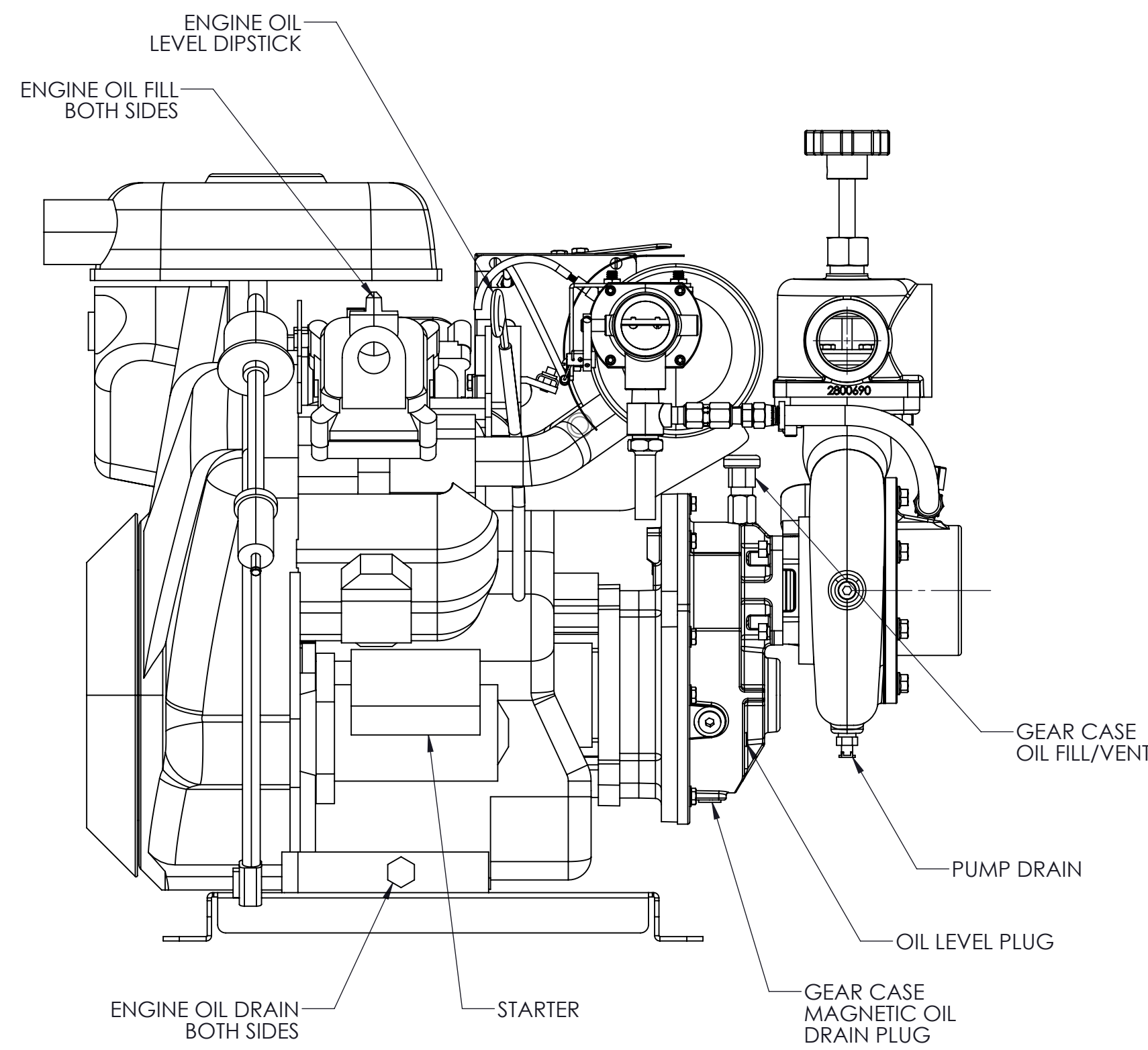
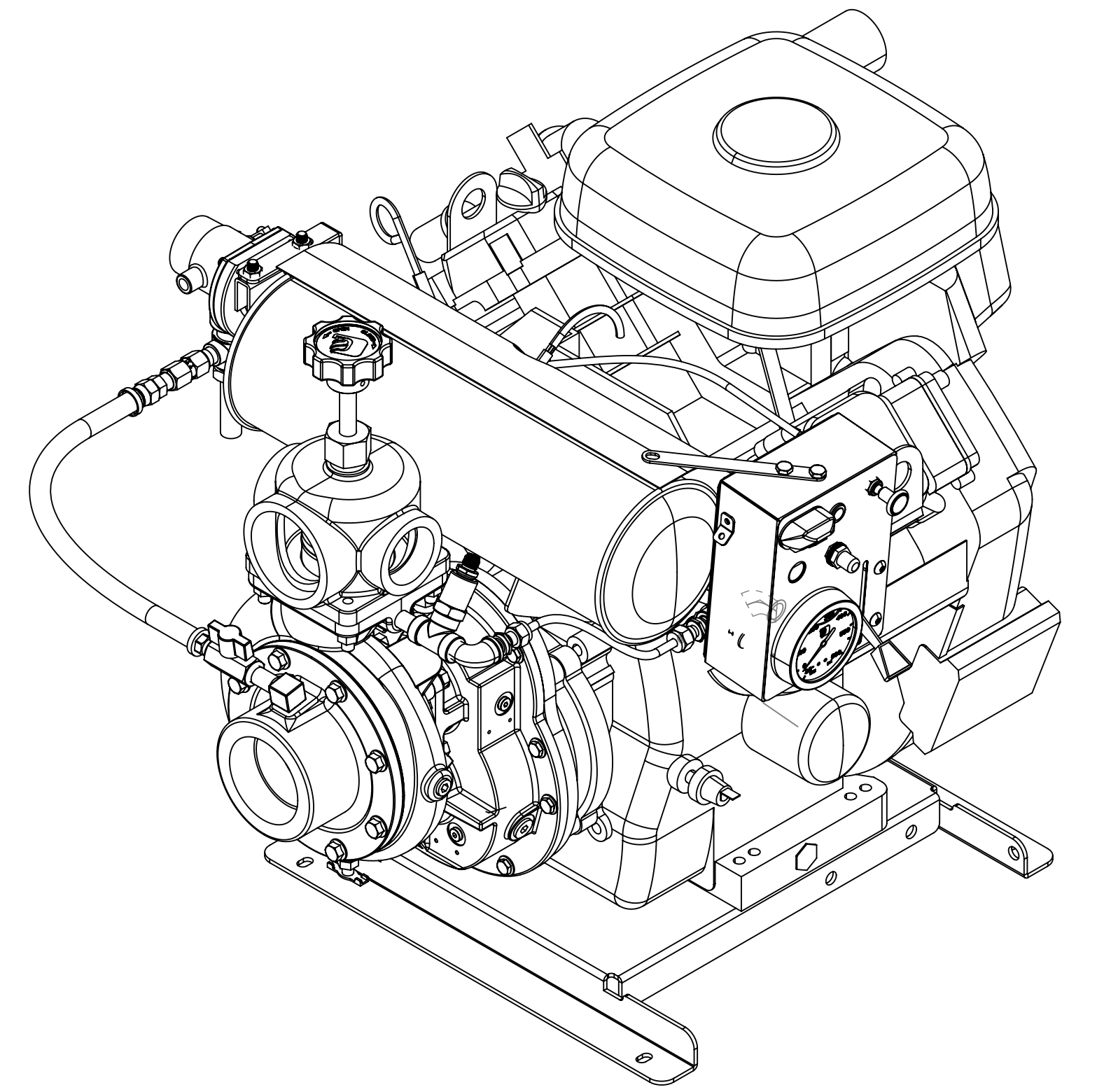
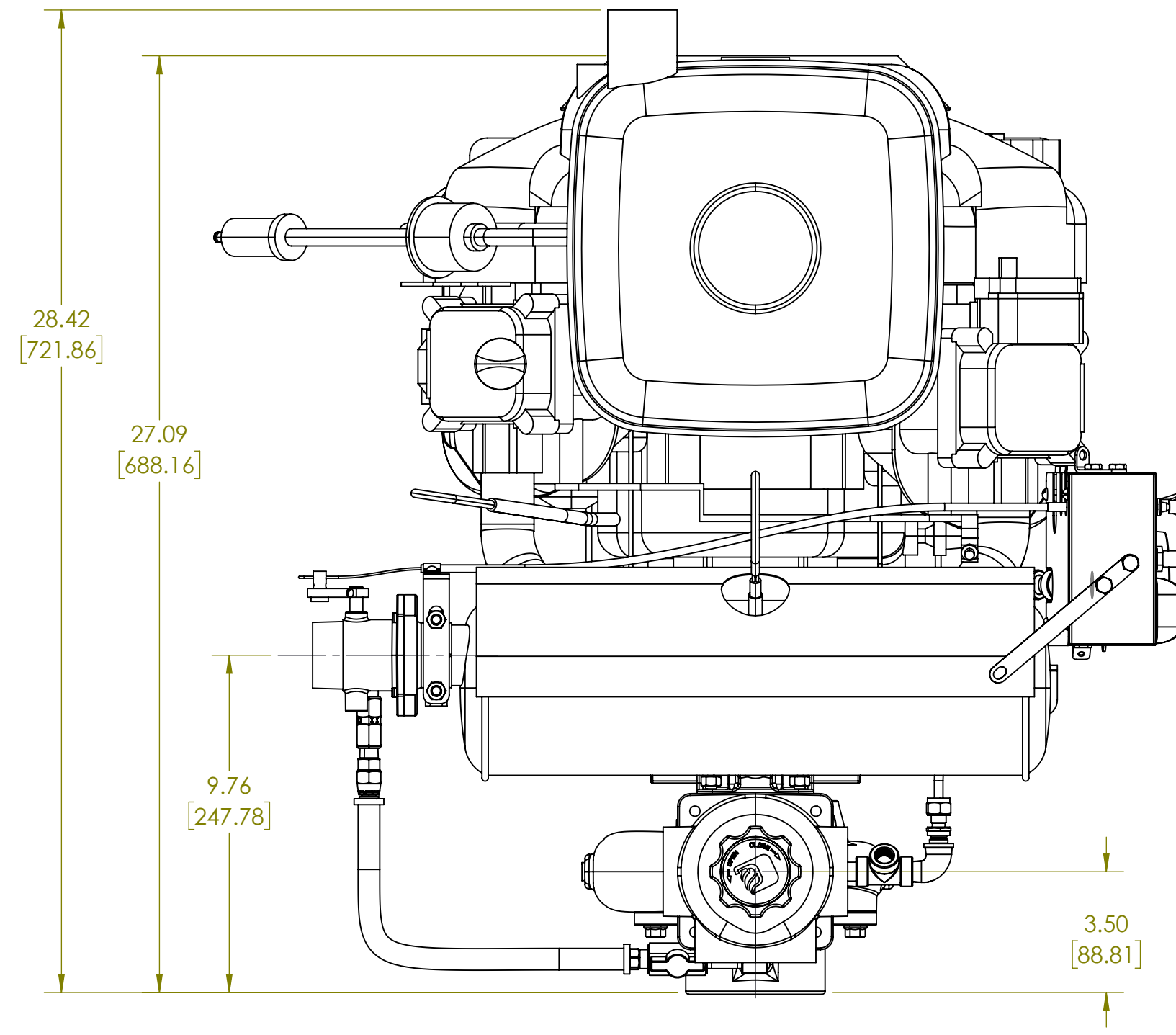