

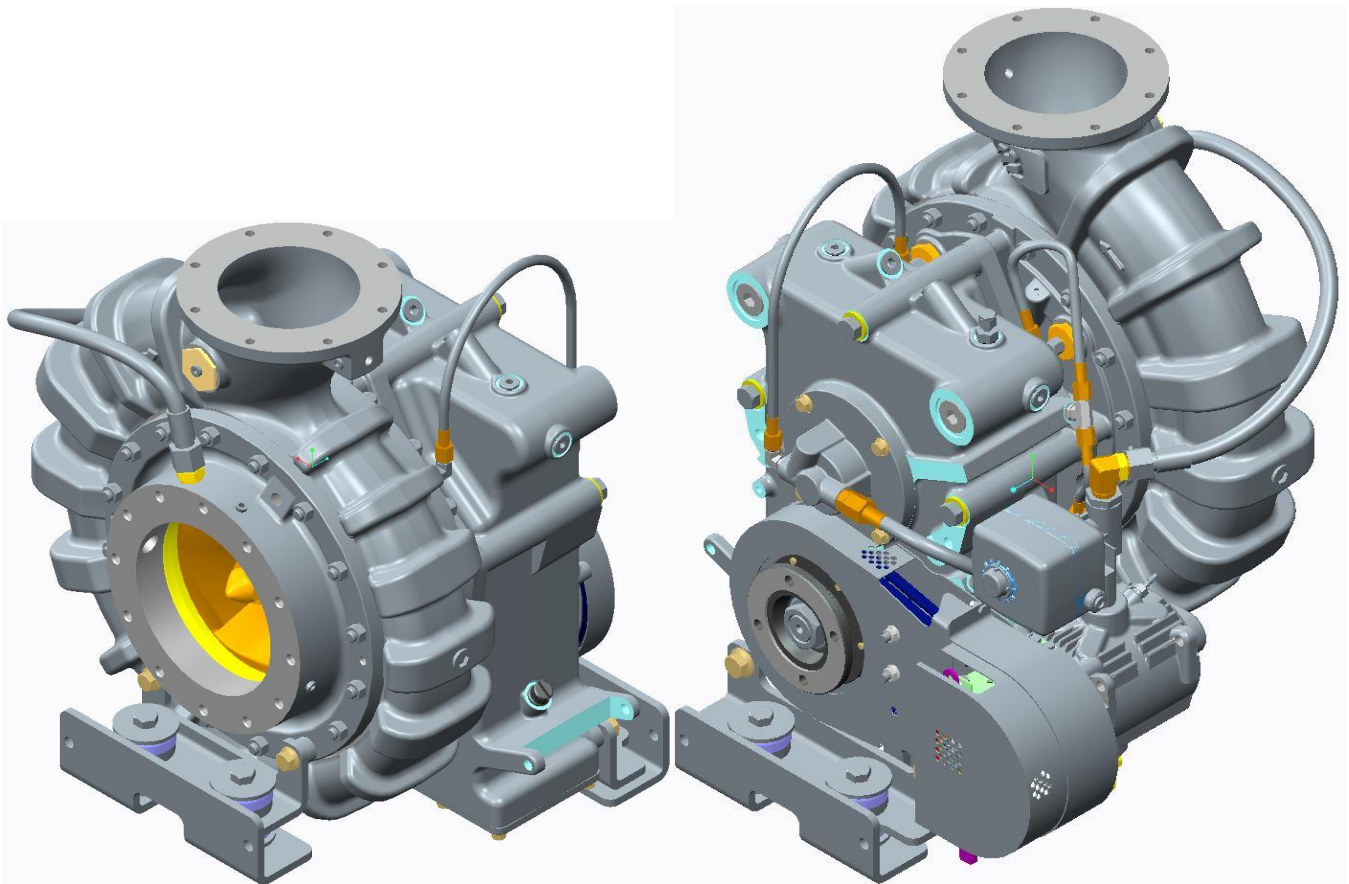

# **INSTALLATION, OPERATION, MAINTENANCE, REPAIR AND TROUBLESHOOTING INSTRUCTIONS FOR THE ZSP Fire Pump**



**Corporate Office:**

325 Spring Lake Drive  
Itasca, Illinois 60143-2072  
800-323-0244, fax (708) 345-8993

**Pump Manufacturing:**

1051 Palmer St.  
Chippewa Falls, WI 54729  
800-634-7812, Fax (715) 726-2656

**Apparatus Division:**

920 Kurth Rd.  
Chippewa Falls, WI 54729  
800-527-0068, Fax 726-2648

**WWW.DARLEY.COM**

**This manual is for DARLEY FIRE PUMP:**  
Model: ZSP Pump Serial Number: \_\_\_\_\_

Prepared by: RJG  
Approved by: WAH  
Revised by: WAH Via ECO 11337

Rev. A  
Date: 03/16/12  
Rev. Date: 02/19/2016  
1200643.doc

# Introduction

This manual provides information for the correct safety, installation, operation, maintenance, repair, and troubleshooting of the Darley ZSP pump system. Please read and follow these instructions thoroughly before putting the system in service. Doing so will ensure optimal performance and long life of your equipped apparatus.

The manual is divided into 5 sections plus an appendix. Each section details the operation, safety, use, and maintenance of the ZSP pump system. The appendix includes supplementary information.

## **Section 1**      **Definition of Symbols and Immediate Safety Information**

## **Section 2**      **General Information and Operations**

**Recommendations**

**PTO Information**

**General Operations Info**

**Definitions**

**NFPA, Discharge, Reach and Friction Loss Tables**

## **Section 3**      **ZSP Fire Pump Installation**

**U-Joints**

**Driveline and Mounting**

**U-Joint Bearing Caps, Bolts and Straps Table**

## **Section 4**      **ZSP Fire Pump Detail**

**Operation**

**Maintenance**

**Components**

## **Section 5**      **Optional Equipment**

## **Appendix**      **Electric Belt-Driven Primer Clutch Maintenance and Repair Guide**

**Detailed Specifications**



# **Table of Contents**

## **Type ZSP Fire Pump**

**ALL DOCUMENTS ARE FOUND IN THIS MANUAL IN THE ORDER THEY ARE LISTED (left to right and top to bottom)**

Safety ----- 1200643

### **SECTION 1 – Definition of Symbols and Immediate Safety Information**

Safety Symbol Definitions and Immediate Safety Information ----- 1200643

### **SECTION 2 – General Information and Operations**

General Operation ----- Recommendations – 1200514  
PTO Pump Shift – 1200591, 1200590  
General Operations Info - 1200509  
Definitions, Operating Characteristics of Pumps, and Conversion Factors - 1200510  
NFPA 1901 Test Table - 1201500  
Discharge Tables - 1201501  
Reach and Friction Loss Tables – 1201502

### **SECTION 3 – Installation**

Installation ----- 1201050  
Driveline Guideline Drawing – DGM1301  
ZSP Suction Pipe Mounting Bracket Detail – DGM2902  
Suction Mounting Bracket Pivot Detail – DGM1302  
ZSP Standard Transmission Mounting Bracket Detail – DGM2908  
Vibration isolating mounting bracket assembly for the pump’s suction head – DGM2905  
Vibration isolating mounting bracket assembly for the pump’s gearbox – DGM2906  
Mounting Bracket – 4042200  
Mounting Rubber Isolator – 4421804  
Mounting Isolator Snubbing Washer – 3603931  
Pump Heater Core Plumbing Detail – DGS0400  
PTO Pump Engagement Electrical Schematic – DGS1100  
ZSP Installation Manual Appendix SPICER DRIVELINE GUIDE J3311-1-DSSP – 1201026

### **SECTION 4 – Pump Detail**

Description, Operation & Maintenance, & Lubrication----- 1200643  
Related Drawings ----- *Pump Cross Section & Explode Drawing* – DZC0006  
*Trans. Cross Section & Explode Drawing* – DZC0019 & DZC0020  
*Pump & Trans. Dimensional Drawings* – DZD0034, DZD0035, DZD0036 & DZD0037  
Mechanical Seal ----- 1200583  
Seal Installation Instruction – 1201040

Prepared by: RJG  
Approved by: WAH  
Revised by: WAH Via ECO 11337

Rev. A  
Date: 03/16/12  
Rev. Date: 02/19/2016  
1200643.doc

Electrically Clutched Belt Driven Primer ----- 1200644  
Primer - DVC0317-DVC0320

**SECTION 5 – Optional Equipment**

Multiple Drain Valve -----DGC0904

Ball Valve ----- 1200000  
Valve Cross Section - DGC0100

Relief Valve “Discharge Valve” ----- 1200503  
RV and Remote Head Schematic and Cross Section- DGC0141  
RV and Remote Head Dimensional - DGD0800  
RV Alarm Installation – 1201002

Butterfly Valve -----DGD0104  
DGD0101  
1200572

Pump Overheat Protection----- DGM0117  
Overheat Valve 12VDC - 5209401  
Overheat Valve 24VDC - 5209402

**Appendix**

Detailed Specifications----- 1200643

Contacts ----- 1200643



# **Section 1**

## **Definition of Symbols and Immediate Safety Information**

## **IMPORTANT**

Throughout this manual will find Caution, Warning and Danger symbols. Please pay close attention to these symbols as they are for your safety.

** DANGER** - Signifies an imminently hazardous situation that could result in death or serious injury.

** WARNING** or  **WARNING** - Signifies a potentially hazardous situation that could result in death or serious injury.

** CAUTION** - Signifies a potentially hazardous situation that might result in minor or moderate injury.

** CAUTION** - Signifies a potentially hazardous situation that might result in property damage.

Ignoring any of these identified hazards is not recommended. W.S. Darley does not advise such actions or take responsibility for the actions of any operator of this unit.

# **SAFETY**

Always read safety instructions indicated by any of the above symbols.

## **⚠ WARNING**

- 1) Open and close valves slowly.
- 2) Be prepared for high nozzle reactions – open nozzle slowly.

## **⚠ WARNING**

- 1) Do not exceed system rated pressure of 250 PSI, capacity of 3500 GPM or impeller speed of 3500 RPM. If assistance is needed in determining engine speed to impeller speed correlation, contact W.S. Darley Customer Service.
- 2) Observe local regulations on the use of hearing protection.
- 3) Use only hoses with pressure rating higher than their intended use.
- 4) Remove all pressure from hoses before disconnecting.
- 5) Shutdown and depressurize completely before attempting maintenance.
- 6) Use of wheel chocks or blocks is highly recommended.

## **⚠ WARNING**

Relay pumping is acceptable as long as system rated pressures are not exceeded. Receiving pump should be equipped with sufficient safety relief type devices, such as Suction Relief Valves and/or Discharge Relief Valves. Failure to follow this recommendation could result in phenomena such as water hammer and system pressure spikes. Such occurrences can cause severe personnel injury and severe equipment damage.

## **⚠ WARNING**

Great care must be taken in the layout of pump systems drivelines. Interference and driveline vibration must be considered. A sufficiently experienced installer with knowledge of driveline considerations, proper layout and recommended guidelines should be utilized as well as a proper CAD system for technically precise layouts. Installation of said drivelines should not occur until a proper analysis is performed by either said drafter or W.S. Darley. Darley utilizes and can distribute the Allison Driveline Analysis program which they use for said analysis, along with an instruction for use.

Failure to do said layout and analysis could result in severe injury and damage to equipment, including items not furnished by Darley, including but not limited to: drive tubes, hanger bearings, u-joint crosses, gears, rear differentials, and main truck transmissions.





Exposed rotating drive-shafts should be guarded.

It is highly recommended by Darley to use safety rings around drive tubes. Especially near connecting u-joint crosses. Such safety rings would be sufficiently attached to the chassis frame and sufficiently strong enough to prevent a broken u-joint assembly from allowing a driveline to slide out from underneath the truck at high speeds while still rotating, causing severe personnel injury. Said safety rings would be larger than the drive tube OD and provide enough clearance for dynamic non-rotational movement of the drivelines through loaded and unloaded conditions, driving operations and where chassis flex may occur.



**Darley**  
**Pump Division**  
**1051 Palmer St.**  
**Chippewa Falls, WI 54729**  
**715-726-2650**

## **Technical Bulletin on PTO Mounted Fire Pump Drivelines**

1202520

FEB, 25 2016

Great care must be taken in the layout of pump drivelines. Interference and driveline vibration must be considered. An experienced installer with knowledge of driveline considerations, proper layout and recommended guidelines should be utilized as well as proper CAD systems for driveline layouts. Installation of the driveline should not occur until a proper analysis is performed by either a qualified driveline specialist or W.S. Darley. W.S. Darley utilizes, can distribute and can train qualified individuals to use the Allison Multiple Joint Driveline Analysis program.

W.S. Darley requires that Power Take Off (PTO) driven pumps have at most 500 radians per second<sup>2</sup> torsional vibration and at most 1000 radians per second<sup>2</sup> inertial drive torsional vibration, as calculated by the Allison Multiple Joint Driveline Analysis program, for a completed driveline installation. A completed driveline installation includes the entire multi-driveshaft assembly from the power source of the PTO output flange to the input flange of the PTO driven pump.

Failure to design and analyze a proper driveline layout could result in severe injury and damage to equipment, including but not limited to: the water pump, the water pump transmission, drive tubes, hanger bearings, u-joint crosses, gears, the rear differential, and the main truck transmission.

Questions can also be directed to our Customer Service Department at  
800-634-7812 or 715-726-2650.

# **Section 2**

## **General Information and Operations**

# ***THINGS TO REMEMBER***

## SUMMARY OF THINGS TO REMEMBER

1. Always shift pump clutches with engine clutch disengaged.
2. Do not clash clutch gears when shifting.
3. Close booster valves, drain valves, cooling line and third stage discharge valve before attempting to prime the pump.
4. Always keep primer shut-off valve closed, except while priming.
5. Re-open and close primer valve to re-prime or eliminate trapped air from suction line.
6. Always drive a midship mounted split-shaft pump with truck transmission in the gear recommended by the chassis manufacturer.
7. Never run the pump without water in it except momentarily while priming.
8. Accelerate and retard speed of engine gradually.
9. Watch the engine temperature, and start the cooling water at the first signs of overheating.
10. Keep good gaskets in suction hoses, and handle carefully to avoid damage to coupling threads.
11. Air leakage into suction lines is the most frequent source of trouble when pumping from a suction lift (draft).
12. Always use a suction strainer when pumping from draft, and a hydrant strainer when pumping from a hydrant.
13. Foreign matter in impellers is a result of failure to use adequate strainers and is a common source of trouble.
14. Drain pump immediately after each run. This is especially critical in freezing conditions.
15. Do not run the pump long with discharge completely shut off.
16. Do not close a "Shutoff" nozzle when pumping with motor throttle wide open, unless relief valve or pressure regulator is set for the correct pressure.
17. Keep the pump gear case filled with oil to the level of the oil level plug/dipstick.
18. Check oil level in the pump transmission after every 25 hours of operation or 3 months, and changed it after every 50 hours of operation or 6 months.
19. In such equipped transmissions, once the oil is drained, remove the strainer screen oil sump fitting and thoroughly cleanse in a parts washer or with isopropyl alcohol, ensuring any debris is washed away.
20. If pump is equipped with a Darley plastallic (injection) packing shaft seal, check the drip rate frequently, and adjust according to the packing adjustment instruction, as required. The drip rate may vary between 5 and 60 drops per minute.
21. Work all suction and discharge valves often to ensure free and easy operation.



***PTO SAFETY  
AND  
SHIFTING INFORMATION***

## PTO Safety Information

These instructions are for your safety and the safety of the end user. Read them carefully until you understand them.

### **General Safety Information**

#### **To prevent injury to yourself and/or damage to the equipment:**

- Read carefully all owner's manuals, service manuals, and/or other instructions.
- Always follow proper procedures, and use proper tools and safety equipment.
- Be sure to receive proper training.
- Never work alone while under a vehicle or while repairing or maintaining equipment.
- Always use proper components in applications for which they are approved.
- Be sure to assemble components properly.
- Never use worn-out or damaged components.
- Always block any raised or moving device that may injure a person working on or under a vehicle.
- Never operate the controls of the Power Take-Off or other driven equipment from any position that could result in getting caught in the moving machinery.

### **Proper Matching of P.T.O.**



**WARNING:** A Power Take-Off must be properly matched to the vehicle transmission and to the auxiliary equipment being powered. An improperly matched Power Take-Off could cause severe damage to the vehicle transmission, the auxiliary driveshaft, and/or to the auxiliary equipment being powered. **Damaged components or equipment could malfunction causing serious personal injury to the vehicle operator or to others nearby.**

#### **To avoid personal injury and/or equipment damage:**

- Always refer to Chelsea catalogs, literature, and owner's manuals. Follow Chelsea recommendations when selecting, installing, repairing, or operating a Power Take-Off.
- Never attempt to use a Power Take-Off not specifically recommended by Chelsea for the vehicle transmission.
- Always match the Power Take-Off's specified output capabilities to the requirements of the equipment to be powered.
- Never use a Power Take-Off whose range of speed could exceed the maximum.

### **Cold Weather Operation of Powershift P.T.O.**



**WARNING:** During extreme cold weather operation [32° F (0°C) and lower], a disengaged Powershift Power Take-Off can momentarily transmit high torque that will cause unexpected output shaft rotation. This is caused by the high viscosity of the transmission oil when it is extremely cold. As slippage occurs between the Power Take-Off clutch plates, the oil will rapidly heat up and the viscous drag will quickly decrease.

The Power Take-Off output shaft rotation could cause unexpected movement of the driven equipment resulting in serious personal injury, death, or equipment damage.

#### **To avoid personal injury or equipment damage:**

- Driven equipment must have separate controls.
- The driven equipment must be left in the disengaged position when not in operation.
- Do not operate the driven equipment until the vehicle is allowed to warm up.



**This symbol warns of possible personal injury.**

Reprinted with permission from: Parker Hannifin Corporation, Chelsea Products Division  
Bulletin HY25-1380-M1/US, April 2002

## Rotating Auxiliary Driveshafts



### **WARNING:**



- Rotating auxiliary driveshafts are dangerous. You can snag clothes, skin, hair, hands, etc. This can cause serious injury or death.
- Do not go under the vehicle when the engine is running.
- Do not work on or near an exposed shaft when the engine is running.
- Shut off the engine before working on the Power Take-Off or driven equipment.
- Exposed rotating driveshafts must be guarded.

## Guarding Auxiliary Driveshafts



**WARNING:** We strongly recommend that a Power Take-Off and a directly mounted pump be used to eliminate the auxiliary driveshaft whenever possible. If an auxiliary driveshaft is used and remains exposed after installation, it is the responsibility of the vehicle designer and P.T.O. installer to install a guard.

## Using Set Screws



**WARNING:** Auxiliary driveshafts may be installed with either recessed or protruding set screws. If you choose a square head set screw, you should be aware that it will protrude above the hub of the yoke and may be a point where clothes, skin, hair, hands, etc. could be snagged. A socket head set screw, which may not protrude above the hub of the yoke, does not permit the same amount of torquing as does a square head set screw. Also, a square head set screw, if used with a lock wire, will prevent loosening of the screw caused by vibration. Regardless of the choice made with respect to a set screw, an exposed rotating auxiliary driveshaft must be guarded.

## Important: Safety Information and Owner's Manual

Chelsea Power Take-Offs are packaged with safety information decals, instructions, and owner's manual. These items are located in the envelope with the P.T.O. mounting gaskets. Also, safety information and installation instructions are packaged with some individual parts and kits. **Be sure to read the owner's manual before installing or operating the P.T.O.** Always install the safety information decals according to the instructions provided. Place the owner's manual in the vehicle glove compartment.



### **WARNING: Operating the P.T.O. with the Vehicle in Motion**

Some Power Take-Offs may be operated when the vehicle is in motion. To do so, the P.T.O. must have been properly selected to operate at highway speeds and correctly matched to the vehicle transmission and the requirements of the driven equipment.

If in doubt about the P.T.O. specifications and capabilities, avoid operating the P.T.O. when the vehicle is in motion. Improper applications and/or operation can cause serious personal injury or premature failure of the vehicle, the driven equipment, and/or the P.T.O.

Always remember to disengage the P.T.O. when the driven equipment is not in operation.



**This symbol warns of possible personal injury.**

Reprinted with permission from: Parker Hannifin Corporation, Chelsea Products Division  
Bulletin HY25-1380-M1/US, April 2002

## PTO PUMP SHIFTING PROCEDURE

This pump is driven by a transmission mounted (SAE) PTO, a front-of-engine crank shaft PTO, or engine flywheel PTO. Depending on the PTO and transmission configuration, the PTO may be either a sliding gear type or “hot shift” clutch type. This power take-off is normally shifted from within the driver’s compartment. In most cases, if the PTO is driven via a manual transmission, the truck clutch must be disengaged while shifting the PTO. The PTO should only be engaged at a low engine rpm, idle up to 1000 rpm maximum. Review and understand the PTO manufacturer’s safety and operating instructions before attempting operation.

If the apparatus manufacturer has configured the apparatus per NFPA 1901, Standard for Automotive Fire Apparatus, 2009 Edition, the following sections apply:

### **16.10.4 Stationary Pump Driven Through Transmission-Mounted PTO, Front-of-Engine Crankshaft PTO, or Engine Flywheel PTO – Automatic Chassis Transmission.**

Where the apparatus is equipped with an automatic chassis transmission, the water pump is driven by a transmission-mounted (SAE) PTO, front-of-engine crankshaft PTO, or engine flywheel PTO, and the apparatus is to be used for stationary pumping only with the chassis transmission in neutral, an interlock system shall be provided to ensure that the pump drive system components are engaged in the pumping mode of operation so that the pump system can be operated from the pump operator’s position.

16.10.4.1 A “Pump Engaged” indicator shall be provided both in the driving compartment and on the pump operator’s panel to indicate that the pump shift has been successfully completed

16.10.4.2 An “OK to Pump” indicator shall be provided in the driving compartment to indicate that the pump is engaged, the chassis transmission is in neutral, and the parking brake is engaged.

### **16.10.5 Stationary Pump Driven Through Transmission-Mounted PTO, Front-of-Engine Crankshaft PTO, or Engine Flywheel PTO – Manual Chassis Transmission.**

Where the apparatus is equipped with a manual chassis transmission, the water pump is driven by a transmission-mounted (SAE) PTO, front-of-engine crankshaft PTO, or engine flywheel PTO, and the apparatus is to be used for stationary pumping only with the chassis transmission in neutral, an interlock system shall be provided to ensure that the pump drive system components are engaged in the pumping mode of operation so that the pump system can be operated from the pump operator’s position.

16.10.5.1 A “Pump Engaged” indicator shall be provided both in the driving compartment and on the pump operator’s panel to indicate that the pump shift has been successfully completed

16.10.5.2 An “OK to Pump” indicator shall be provided in the driving compartment to indicate that the pump is engaged, the chassis transmission is in neutral, and the parking brake is engaged.

### **16.10.6 Stationary Pump and “Pump-and-Roll” – Automatic Chassis**

**Transmission.** Where the water pump is driven by a transmission-mounted (SAE) PTO, front-of-engine crankshaft PTO, or engine flywheel PTO, and the apparatus is designed to be used in both the stationary pumping mode and the “pump-and-roll” pumping mode with the automatic chassis transmission in neutral for stationary pumping and in a road gear for pump-and-roll pumping, an interlock system shall be provided to ensure that the pump

## PTO PUMP SHIFTING PROCEDURE

drive system components are engaged in the pumping mode of operation so that the apparatus can be operated in either stationary or pump-and-roll pumping modes.

16.10.6.1 A "Pump Engaged" indicator shall be provided both in the driving compartment and on the pump operator's panel to indicate that the pump shift has been successfully completed

16.10.6.2 An "OK to Pump" indicator shall be provided in the driving compartment to indicate that the pump is engaged, the chassis transmission is in neutral, and the parking brake is engaged.

16.10.6.3 An "OK to Pump and Roll" indicator shall be provided in the driving compartment and shall be energized when the pump is engaged, the chassis transmission is in road gear, and the parking brake is released.

16.10.6.4 When the "OK to Pump and Roll" indicator is energized, the "OK to Pump" indicator shall not be energized.

### 16.10.7 Stationary Pump and "Pump-and-Roll" – Manual Chassis

**Transmission.** Where the water pump is driven by a transmission-mounted (SAE) PTO, front-of-engine crankshaft PTO, or engine flywheel PTO, and the apparatus is designed to be used in both the stationary pumping mode and the pump-and-roll pumping mode with the chassis transmission in neutral for stationary pumping or in a road gear for pump-and-roll pumping, an interlock system shall be provided to ensure that the pump drive system components are properly engaged in the pumping mode of operation so that the apparatus can be operated in either stationary or pump-and-roll pumping modes.

16.10.7.1 A "Pump Engaged" indicator shall be provided both in the driving compartment and on the pump operator's panel to indicate that the pump shift has been successfully completed

16.10.7.2 An "OK to Pump" indicator shall be provided in the driving compartment to indicate that the pump is engaged and the parking brake is engaged.

16.10.7.3 An "OK to Pump and Roll" indicator shall be provided in the driving compartment and shall be energized when the pump is engaged and the parking brake is released.

16.10.7.4 When the "OK to Pump and Roll" indicator is energized, the "OK to Pump" indicator shall not be energized.

### 16.10.10 Pump Operator's Panel Engine Speed Advancement – Automatic Transmission.

16.10.10.1 An engine speed control shall be provided at the pump operator's panel.

16.10.10.2 A "Throttle Ready" indicator that lights when the pump is in the "OK to Pump" mode shall be provided on the pump operator's panel.

16.10.10.3\* The "Throttle Ready" indicator at the pump operator's panel shall be permitted to light when the chassis transmission is in neutral and the parking brake is engaged.

A.16.10.10.3 Engine speed advancement control at the operator's panel might be required for apparatus with the need to control the engine speed for operation of a generator, aerial device, alternator, or other chassis engine-driven device. The indicating device for this "Throttle Ready" condition is the same indicating device as in 16.10.10.2.

Other apparatus may not have equipment for which there is a need to control engine speed from the pump operator's panel. Engine speed control at the pump operator's panel for these apparatus may not be desirable since, on many chassis engines, activating remote throttle operation will automatically disable the in-cab accelerator pedal. For such apparatus, engine speed advancement control at the pump operator's panel is not



## **PTO PUMP SHIFTING PROCEDURE**

required when the chassis transmission is in neutral and the parking brake is engaged, and "Throttle Ready" indication for this condition is not required.

16.10.10.4 An interlock system shall be provided to prevent advancement of the engine speed at the pump operator's panel unless the apparatus has "Throttle Ready" indication.

16.10.10.5 Loss of power to the interlock system in 16.10.10.4 shall return the engine speed to idle and prevent advancement from the pump operator's panel.

### **16.10.11 Pump Operator's Panel Engine Speed Advancement – Manual Transmission.**

16.10.11.1 An engine speed control shall be provided at the pump operator's panel.

16.10.11.2 A "Throttle Ready" indicator that lights when the pump is in the "OK to Pump" mode shall be provided on the pump operator's panel.

16.10.11.3\* The "Throttle Ready" indicator at the pump operator's panel shall be permitted to light when the parking brake is engaged.

A. 16.10.11.3 Engine speed advancement control at the operator's panel might be required for apparatus with the need to control the engine speed for operation of a generator, aerial device, alternator, or other chassis engine-driven device. The indicating device for this "Throttle Ready" condition is the same indicating device as in 16.10.11.2.

Other apparatus may not have equipment for which there is a need to control engine speed from the pump operator's panel. Engine speed control at the pump operator's panel for these apparatus may not be desirable since, on many chassis engines, activating remote throttle operation will automatically disable the in-cab accelerator pedal. For such apparatus, engine speed advancement control at the pump operator's panel is not required when the chassis transmission is in neutral and the parking brake is engaged, and "Throttle Ready" indication for this condition is not required.

16.10.11.4 Loss of power to the interlock system in 16.10.11.3 shall return the engine speed to idle and prevent advancement from the pump operator's panel.

16.10.12 If a pump shift manual override device is provided the "Pump Engaged", "OK to Pump", and "Throttle Ready" indicators and the pump operator's panel engine speed advancement interlock system shall be operationally functional when the manual override device is used to shift the pump.

### **16.10.13 Pump Operator's Panel Engine Speed Advancement – Automatic Transmission.**

16.10.13.1 With parallel/series centrifugal pumps, the control positions for parallel operation (volume) and series operation (pressure) shall be indicated.

16.10.13.2 The control for changing the pump from series to parallel, and vice versa, shall be operable at the pump operator's position.

## PTO PUMP SHIFTING PROCEDURE

For **STATIONARY** pumping, proceed as follows for pump engagement:

1. Set parking brake.
2. Shift chassis transmission to neutral.
3. Reduce engine speed to idle or below 1000 rpm.
4. Following the PTO manufacturer's shifting instructions, engage chassis PTO. *The "Pump Engaged" indicator both in the driving compartment and on the pump operator's panel will indicate if the pump shift has been successfully completed. The "OK to Pump" indicator in the driving compartment will indicate that the pump is engaged, the chassis transmission is in neutral, and the parking brake is engaged. The "Throttle Ready" indicator at the pump operator's panel is now illuminated.*
5. Prime the pump (see priming instructions). Primer motor should be engaged within 2 minutes of PTO engagement. Pump should then prime within 1 minute of primer operation. If the pump can not be primed within 3 minutes of PTO engagement, disengage PTO and troubleshoot priming difficulty. Do not run the pump dry for extended periods of time.
6. Confirm that the "Throttle Ready" indicator at the pump operator's panel is now illuminated.
7. Observe discharge pressure gage on panel while advancing vernier throttle, to ensure that it is indicating pressure. If Pump is not engaged, no pressure will show.
8. Remember, the vernier throttle has a quick release emergency center button. If the truck moves, immediately push the center emergency button all the way in to close throttle.
9. To ensure maximum operational life for the PTO, driveline, and pump components, increase engine speed to 1000 rpm minimum when the PTO is engaged and the pump is flowing water. This slight increase in rpm induces a small load on the drive system. This load will eliminate the system rattle produced by the clearances in the PTO and pump gears being excited by the combustion engine power strokes.

To disengage the pump, reduce engine rpm to idle and shift PTO out of gear.

**IMPORTANT:** Failure to follow proper shifting or operating sequences will result in premature PTO failure with possible damage to other components

## PTO PUMP SHIFTING PROCEDURE

For **PUMP and ROLL** pumping, proceed as follows for pump engagement:

1. Set parking brake.
2. Shift chassis transmission to neutral.
3. Reduce engine speed to idle or below 1000 rpm.
4. Following the PTO manufacturer's shifting instructions, engage chassis PTO. *The "Pump Engaged" indicator both in the driving compartment and on the pump operator's panel will indicate if the pump shift has been successfully completed. The "OK to Pump" indicator in the driving compartment will indicate that the pump is engaged, the chassis transmission is in neutral, and the parking brake is engaged. The "Throttle Ready" indicator at the pump operator's panel that is now illuminated.*
5. Prime the pump (see priming instructions). Primer motor should be engaged within 2 minutes of PTO engagement. Pump should then prime within 1 minute of primer operation. If the pump can not be primed within 3 minutes of PTO engagement, disengage PTO and troubleshoot priming difficulty. Do not run the pump dry for extended periods of time.
6. Return to the driving compartment driver's position.
7. Release parking brake.
8. Shift chassis transmission into road gear. *The "Pump Engaged" indicator both in the driving compartment and on the pump operator's panel will indicate if the pump shift has been successfully completed. The "OK to Pump" indicator will not be illuminated. The "OK to Pump and Roll" indicator in the driving compartment will indicate that the pump is engaged, the chassis transmission is in drive, and the parking brake is released.*
9. While advancing foot throttle, observe discharge pressure gage in the cab. If the pump is properly engaged and primed, discharge pressure will increase as engine rpm increases. Use care when in the pump and roll mode to maintain a steady engine rpm (constant pressure) and do not exceed rated pump pressure rating.
10. To ensure maximum operational life for the PTO, driveline, and pump components, increase engine speed to 1000 rpm minimum when the PTO is engaged and the pump is flowing water. This slight increase in rpm induces a small load on the drive system. This load will eliminate the system rattle produced by the clearances in the PTO and pump gears being excited by the combustion engine power strokes.

To disengage the pump, reduce engine rpm to idle and shift PTO out of gear.

**IMPORTANT:** Failure to follow proper shifting or operating sequences will result in premature PTO failure with possible damage to other components.

# ***GENERAL OPERATIONS INFO***

Prepared by: RJG  
Approved by: WAH  
Revised by: WAH Via ECO 11337

Rev. A  
Date: 03/16/12  
Rev. Date: 02/19/2016  
1200643.doc

# **WARNING: DO NOT USE THIS PUMP FOR HOSE TESTING**

## **OPERATING THE ENGINE**

After the pump has been primed, the engine speed should be increased gradually -- never jerk throttle wide open. Likewise, the engine speed should be decreased gradually when shutting down.

Watch the pump pressure gage and open throttle only enough to give the desired pressure. The pressure may rise high enough to burst the discharge hose, when using small nozzles, if the engine is given full throttle (except pumps equipped with pressure regulators set for desired pressure).

Never run engine at high speeds except when pump is primed and ready to discharge water.

## **COOLING THE ENGINE**

NFPA 1901 requires that a supplementary heat exchanger cooling system be provided. On most models, this heat exchanger is an integral part of the pump, and the installation of two hoses from the engine cooling system to the pump is all that is required.

On some models an external heat exchanger must be used. In that case two hoses from the engine cooling system and two lines from the pump will run to the heat exchanger.

The cooling line should not be opened until pressure develops in the pump, and pump should never be operated under heavy loads prolonged without an adequate supply of cooling water flowing.

Coolant temperatures should never be allowed to exceed 200° F while pumping and 180° F is usually taken as a safe operating temperature.

Always shut off cooling line when through pumping.

## **SUCTION STRAINERS**

A large suction strainer, which will prevent the passage of a body larger than the pump impeller ports, must always be used on the free end of the suction line when pumping from draft.

The small hydrant strainer must always be inserted in the suction manifold of pump, when pumping from hydrants and at all other times except when maximum capacity is required from draft.

Failure to use a strainer at all times when pumping will cause serious trouble by clogging the pump because, even in water mains, foreign matter is invariably present, and will be drawn into pump by the high velocity of the water entering.

## **SUCTION LINE**

The suction line of a fire pump can be the source of more operating difficulties than all the rest of the pump when working with a suction lift. Faults in the suction line which cause trouble in operation are as follows:

### **AIR LEAKS:**

A small amount of air, expanding in the vacuum of the suction line, displaces a considerable volume of water which subtracts from the capacity that the pump is able to deliver, making the priming difficult or causing the pump to lose its prime. Therefore, it is absolutely essential to keep the suction line and the suction side of pump casing air tight at all time when drafting water.



Air leakage into pump while operating is usually indicated by a rattling sound in pump casing, miniature explosions in stream issuing from the nozzle, or by losing of prime when operating at very low capacities.

The usual cause of leaky suction lines is carelessness in handling of suction hose. Bruising of hose threads by bumping against hard surfaces or sand in the coupling often prevents tightening of the joints up against the gaskets. The hose gaskets are often defective and are sometimes lost without being noticed by the operator.

### **INSUFFICIENT SUBMERGENCE:**

The free end of suction hose must be submerged to a sufficient depth to prevent the entrance of air that may be sucked down from the surface of the water to a considerable depth when operating at large capacities.

Entrance of air into suction lines in this manner is indicated by a small whirlpool, or vortex, on the surface of the water over the end of the hose.

A minimum submergence of 4 times the hose diameter to the upper holes in suction strainer is recommended where full capacity of pump is required. Where sufficient submergence is not possible, a board or sheet of metal laid over end of suction line will keep air from entering.

### **SUCTION LINE ENTRANCE TOO CLOSE TO BOTTOM:**

If the end of suction line is laid on the bottom of the source of supply, a part of the suction opening will be shut off; and if the bottom is soft, the hose will suck itself down into the earth closing more of the opening and loosening sand and mud to be carried into the pump.

The suction entrance should be suspended a foot or more above the bottom, or if this is not possible, it should be laid on a board or piece of sheet metal. A rope tied to the suction strainer is a convenient means of holding it off the bottom.

### **OBSTRUCTION OF SUCTION STRAINER BY FOREIGN MATTER:**

The high velocity of water entering the suction line will carry loose foreign bodies in against the strainer from a considerable distance. Therefore, all weeds and refuse should be removed from close proximity of the suction entrance.

### **SUCTION LINE TOO SMALL OR TOO LONG:**

The flow of water into the pump is opposed by the frictional resistance in the suction line. This friction loss must be added to the height of the pump above the water (static lift) to determine the "total lift" of the pump. When all of the vacuum in the pump (atmospheric pressure) is consumed in raising water through this total lift, then the limit of capacity has been reached. This capacity can be increased only by decreasing total lift. If the static lift cannot be reduced, then the friction loss must be reduced by using a shorter or larger suction hose.

The rated capacity of the pump is guaranteed for a static lift of 10 feet for ratings up to 1500 gpm, with 20 feet of recommended suction hose at 2000 feet. To increase the capacity without reducing the static lift, or to increase lift without sacrificing capacity, requires larger suction hose.

An excessively long suction line is a handicap to any pump, for besides reducing capacity through the added friction loss, it retards priming and it produces a detrimental effect known as "cavitation". This means a separation of the water column in the pump suction, or void spaces, produced by the inertia of the heavy mass of water in the line resisting sudden change in the velocity when the pump starts to deliver or when discharge valves are opened or closed. This phenomenon reduces

capacity further, and usually sets up a vibratory motion and “water hammer” as the water surges in and out of the void spaces.

When operating with a long suction line, the driving engine should be accelerated gradually, the discharge gates opened gradually, and the capacities of the pump should be held down to within the range of smooth performance.

#### **AIR TRAP IN SUCTION LINE:**

If the suction line is laid so that part of it is higher than any other part that is nearer to the pump, as when hose is laid over a high bridge rail, an air trap is formed at the highest part of the hose from which the air cannot be sucked out by the primer. This trapped air is expanded and carried into the pump with the first rush of water causing the pump to immediately lose its prime.

If suction line cannot be laid so that it slopes all the way from pump to water, it can still be primed easily by simply allowing the primer to continue to function until all the trapped air in the hose has been carried into the pump and picked up by the primer.

## TESTING FOR AIR LEAKS

Tests for leakage should be made with the suction hose attached and capped, discharge gate open, and all other openings closed tightly.

Run electric priming pump with primer shut-off valve open, until 22" of Hg is shown on the gage. The vacuum should hold for no more than 10" of drop in 5 minutes before satisfactory performance of pump can be expected.

If excessive leakage of air occurs, the source of leaks can be located by shutting off primer motor, with vacuum at its highest point, and listening for the hiss of air.

In the absence of a vacuum gage, the vacuum in pump may be judged by closing suction opening with the flat of hand or a rubber pad.

Water or air pressure may be applied to pump casing to test for air leakage if more convenient. DO NOT pressurize with air beyond 10 PSI

## SOURCE OF WATER SUPPLY

Water may be drafted from a pond, lake, stream, cistern, stock tank, or well; but whatever the source, the static lift must not exceed 20 feet from the center of the pump to the surface of the water and a lift not exceeding 10 feet is recommended. The source of supply should be reasonably clear and free from foreign matter. It is recommended that all water holes, which may be needed for fire protection, be deepened if necessary and kept free from weeds and refuse. In many fire protection areas, cisterns or reservoirs are built and allowed to fill up with rain water to be used in emergencies.

## PUMPING IN COLD WEATHER

The first insurance against cold weather trouble is to keep fire apparatus stored in heated quarters. All water must be eliminated from pump casing and primer line between periods of operations.

When setting up for pumping, unnecessary delays should be avoided by having thoroughly trained pump operators. Be sure that primer and booster lines are kept closed until ready for use. Having discharge lines ready so that pump may be started as soon as it have become primed. Do not stop flow of water through the pump until ready to drain and return to the station.

Engine Coolant from the engine circulated through the heater jacket in pump casing prevents all ordinary freezing troubles.

## WHEN FINISHED PUMPING

Drain water out of pump casing immediately. (Drain valve is located at lowest point in pump casing, and usually accessible from underneath operators panel.)

Don't forget to close all drain cocks after all water has been drained out. Trouble in priming will follow on the next run if this is forgotten.

Shut off cooling line to make pump ready for priming again.

If pump transmission is equipped with a transmission cooler it must be drained also. If the master drain is located below the cooler outlets it can be connected to the master drain, if not, two separate drains must be connected to the transmission cooler. **Failure to drain transmission cooler may result in water in the gearcase if water in the cooling coil freezes.**

If pump is equipped with a heat exchanger, drain heat exchanger using gravity and vacuum drain on all trucks as follows: Close all open lines and drain cocks. Open cooler valve and open air vent at top or drain cock at bottom of heat exchanger depending on model. With the pump air-tight, open primer with engine running for about a minute and then close primer. Drain pump of water which was deposited when heat exchanger and lines were being drained.

Pump not often used for fire service should be inspected and run periodically to ensure that they will be in readiness for an emergency.

## **PUMPING SALT WATER**

The pump should be flushed out with fresh water immediately after pumping salt water to prevent excessive rusting. (Except pumps which are built of special materials, such as bronze, to resist the corrosive action of the brine.)

When measuring sea water with a Pitot Gage, capacities shown in Table No. 2 should be discounted approximately 1 1/2% to determine the correct capacity.

A centrifugal pump will show 3% higher pressure and require 3% more power when handling sea water than when handling fresh water if operated at the same speed and capacity.

## **TESTING OF EQUIPMENT FOR PRACTICE**

It frequently happens that operators of fire apparatus, who are not thoroughly familiar with its operations, become confused under the stress of emergency and neglect some little detail that may cause trouble or delay in getting the equipment into operation. Therefore, we urge that practice tests be conducted repeatedly until operators are thoroughly trained. More than one person in the department should be a competent operator.

Practice should include pumping from low lifts, high lifts with short and long suction lines, with suction line elevated to form an air trap, and from hydrants, at large and small capacities.

It is important to note the effects of air leaks in hose, insufficient submergence and restriction of suction line. (Suction line can be restricted by placing a can or other strong closure around the suction strainer).

**NEVER BREAK OR RESTRICT SUCTION OR ALLOW AIR TO ENTER SUCTION LINE WHILE ENGINE IS OPERATING WITH THROTTLE OPEN.** This will release the load and allow engine to run away.

Do not allow personnel to hold a large nozzle while working at high pressures for serious accidents may result if hose breaks loose.

## **MEASURING PUMP PERFORMANCE**

Pump performance is measured by the quantity of water it can deliver per minute against a certain pressure called "Total Head" or "Net Pump Pressure", as it is usually termed in fire pump testing.

The net pump pressure is the sum of the pump discharge pressure, as shown on the pressure gage with which the pump is regularly equipped, and the total suction lift converted to equivalent pounds per square inch. If pump is operating from a hydrant, the net pump pressure is the discharge pressure less the incoming pressure from hydrant measured at the suction entrance of pump.

Capacity of fire pump is measured in gallons per minute. The usual method of measurement is to determine the pressure of the jet of water leaving a given size of nozzle by means of a "Pitot Gage" from which the capacity is computed mathematically.

A Pitot Gage consists of a small tube adapted to a point directly into the hose nozzle from the center of the issuing stream, the other end of the tube being connected to an accurate pressure gage.

The nozzle jet drives straight into the Pitot tube and converts the velocity of the jet to pressure which is an accurate measure of velocity of the water as it leaves the nozzle. The tip of the Pitot tube should be one-half the diameter of the nozzle away from nozzle tip while taking reading. Table No. 2 gives nozzle capacities for various Pitot Gage readings.

If a Pilot gage is not available approximate pump capacities can be determined by reference to Table No.3

## ACCEPTANCE TESTS

Acceptance tests require continuous tests of three hours duration: 2 hours at 100% rated capacity and 150 PSI net pump pressure; one-half hour at 70% capacity and 200 PSI; one-half hour at 50% capacity and 250 PSI; and a spurt test at 100% capacity and 165 PSI.

Table No. 1 shows recommended set-ups and gage readings for rating tests.

To adjust nozzle pressure for the correct capacity, while maintaining the correct pump pressure, it is necessary to make simultaneous adjustments of engine throttle and the discharge gate valve, partially closing the latter until just the right discharge resistance is built up.

## ENGINES

A fire pump imposes heavy loads on the engine that drives it, sometimes absorbing all of the power the engine is capable of delivering at full throttle. Continuous pumping gives the engine no time to rest. Therefore, a new engine and pump unit must be thoroughly broken-in before it is required to deliver prolonged maximum pump performance.

We recommend a minimum break in period of 20 hours at light pumping loads, with occasional spurt tests and interruptions. Temperature and lubrication should be checked during this period.

Engine manufacturers' power ratings usually show maximum performance of a selected, factory adjusted engine, operating without fan, generator, muffler or other accessories, and corrected for "ideal" conditions, i.e. sea level barometer (29.92" of mercury) 60°F and high humidity. Therefore, the actual power delivered by an average truck mounted engine is considerably lower than the manufacturers' rating, and allowances must be made in predicting pump performance.

## EFFECTS OF ATMOSPHERIC CONDITIONS ON ENGINE AND PUMP PERFORMANCE

Each one inch of drop in Barometric pressure or each 1000 feet of elevation of the pumping site reduces engine power approximately 3 1/2% for engines not equipped with a turbo charger.

Each 12° rise in temperature above 60° F of carburetor intake air reduces engine power approximately 1%.

Lowering of humidity reduces power slightly.

Each one inch drop in Barometric pressure or each 1000 feet of elevation reduces the maximum possible static lift of a pump approximately one foot.

Temperature of the water supply affects the attainable suction lift of a pump. The effect is slight at low water temperatures but becomes increasingly detrimental as the temperature rises.

A 10° rise from 70°F will subtract about 1/2 foot from the maximum attainable suction lift, while an equal rise from 100°F will reduce the lift at least 1 1/2 feet.

Temperature is an important consideration when pumping from a test pit where the water is heated by recirculation.

**IF FURTHER INFORMATION IS NEEDED, CALL W.S. DARLEY & CO. AT  
CHIPPEWA FALLS, WI. AT 800-634-7812 or 715-726-2650**

***DEFINITIONS, OPERATING  
CHARACTERISTICS OF PUMPS,  
AND CONVERSION FACTORS***

## DEFINITIONS

HEAD OF WATER -- vertical depth of water measured in feet or in pressure per unit or area. In hydraulics, head always represents pressure and it is expressed interchangeably in feet of water or pounds per square inch and sometimes in inches of depth of mercury.

STATIC HEAD -- the pressure that is exerted by a stationary column of water of a given height or depth.

TOTAL HEAD OR TOTAL DYNAMIC HEAD -- the maximum height above the source of supply to which the pump would elevate the water plus all the resistance to flow in the pipe or hose line.

DISCHARGE HEAD -- the pressure measured at the discharge outlet of a pump.

SUCTION HEAD -- the positive pressure measured at the suction entrance of a pump (when pumping from an elevated tank or hydrant).

VELOCITY HEAD -- the equivalent pressure represented by fluid in motion as measured by means of a Pitot Gage.

STATIC LIFT -- the vertical height of the center of the pump above the source of supply (when pump from draft).

TOTAL SUCTION LIFT -- the static lift plus the friction in suction line plus entrance losses.

NET PUMP PRESSURE -- the total dynamic head of the pump.

EFFECTIVE NOZZLE PRESSURE -- the pump discharge pressure minus hose friction plus or minus the difference in elevation above or below pump.

WATER HORSEPOWER - the theoretical power required to deliver a given quantity of water per minute against a given head.

BRAKE HORSEPOWER -- Actual power as delivered by a motor or engine to a driven machine.

PUMP EFFICIENCY -- The quotient of the water horsepower divided by brake horsepower required to produce it.

WATER HAMMER -- a series of shock waves produced in a pipeline or pump by a sudden change in water velocity. A sudden change in flow velocity can result from rapid closure of valves. A pressure wave is set up which travels back and forth in the water column at extremely high speed producing rapid vibrations that may be violent and destructive if the water column is long.

THE MAXIMUM THEORETICAL LIFT of a pump is 34 feet, which is the pressure of the atmosphere at sea level. The maximum practical total lift at sea level is 20 to 25 feet (depending on the type and condition of the pump) and this decreases with drops in barometric pressure.



## **OPERATING CHARACTERISTICS OF PUMPS**

**CENTRIFUGAL PUMPS:** A centrifugal pump develops pressure by centrifugal force of the liquid rotating in the impeller wheel. The pressure developed depends upon the peripheral speed of the impeller (increasing as the square of the speed) and it remains fairly constant over a wide range of capacities up to the maximum output of the pump, if speed remains constant.

If the discharge outlet of a centrifugal pump is entirely shut off, with speed kept constant, there is a small rise in pressure, the water churns in the pump casing and the power drops to a low value. If the discharge is opened wide, with little resistance to flow the pressure drops while the capacity and power both increase to their maximum.

A centrifugal pump is an extremely simple mechanism mechanically, but rather complex hydraulically; in that many factors enter into the design of the impeller and water ways which will affect the pump's efficiency.

**DISPLACEMENT PUMPS:** Rotary and piston pumps are termed "Positive Displacement" pumps because each revolution displaces or discharge (theoretically) an exact amount of liquid, regardless of the resistance. The capacity is, therefore, proportional to the number of revolutions of the pump per minute and independent of the discharge pressure except as it is reduced by "slip" (leakage past the pistons or rotors). For a given speed the power is directly proportional to the head. If the discharge is completely shut off, the pressure, power, and torque climb indefinitely until the drive power is stalled or breakage occurs.

Slip is the greatest factor affecting efficiency of a displacement pump, and this factor is greatly influenced by the condition of and wears on the working parts.

**IF FURTHER INFORMATION IS NEEDED, CALL W.S. DARLEY & CO. AT  
CHIPPEWA FALLS, WI. AT 800-634-7812 or 715-726-2650**

## CONVERSION FACTORS

One pound per square inch	=	2.31 feet of water
	=	2.04 inches of mercury
	=	27.7 inches of water
One foot of water	=	0.43 pounds per square inch
One inch of mercury	=	1.13 feet of water
	=	0.49 pounds per square inch
One cubic foot of water	=	62.4 pounds
	=	7.5 gallons
One gallon of water	=	231 cubic inches
	=	0.13 cubic feet
	=	8.34 pounds
	=	3.8 liters
One Imperial Gallon	=	1.2 U.S. gallons
Atmospheric Pressure (Sea Level)	=	14.8 pounds per square inch
	=	29.9 inches of mercury
	=	34 feet of water

# ***NFPA 1901 TABLES***

**TABLE NO. 1**  
**NFPA 1901 TEST**

Class A							
TEST No.	GPM	Recom- mended Nozzles	Min. Nozzle Press. PSI	Min. Disch. Press. PSI	Min. Net Pump Press. PSI	Disch. Lines	Suction Hose
250 GPM Fire Pump							
1	250	(1), 1"	72	143	150		
2	175	(1), 7/8"	62	194	200	(1), 50'	20' of 3"
3	125	(1), 3/4"	56	244	250		
4	250	(1), 1"	72	158	165		
350 GPM Fire Pump							
1	350	(1), 1-1/4"	58	144	150		
2	245	(1), 1"	69	195	200	(1), 50'	20' of 4"
3	175	(1), 7/8"	62	245	250		
4	350	(1), 1-1/4"	58	159	165		
500 GPM Fire Pump							
1	500	(1), 1-1/2"	57	143	150	(1), 50'	
2	350	(1), 1-1/4"	58	194	200		20' of 4"
3	250	(1), 1"	72	245	250		
4	500	(1), 1-1/2"	57	158	165		
750 GPM Fire Pump							
1	750	(1), 1-3/4" or (2), 1-1/4"	68 66	142	150	(2), 50'	
2	525	(1), 1-1/2"	62	193	200	or	20' of 4-1/2"
3	375	(1), 1-1/4"	66	244	250	(2), 100'	
4	750	(1), 1-3/4" or (2), 1-1/4"	68 66	157	165	Siamesed	
1000 GPM Fire Pump							
1	1000	(1), 2" or (2), 1-1/2"	71 57	142	150	(2), 50'	
2	700	(1), 1-3/4" or (2), 1-1/4"	60 58	193	200	or	20' of 5"
3	500	(1), 1-1/2"	57	244	250	(3), 100'	
4	1000	(1), 2" or (2), 1-1/2"	71 57	157	165	Siamesed	

Min. discharge pressures listed above are for pumps operating with full 10' static suction lift. These pressures must be increased by 1 PSI for each 2.3 ft. less than 10' of lift.

**TABLE NO. 1**  
**NFPA 1901 TEST**

Class A							
TEST No.	GPM	Recom- mended Nozzles	Min. Nozzle Press. PSI	Min. Disch. Press. PSI	Min. Net Pump Press. PSI	Disch. Lines	Suction Hose
1250 GPM Fire Pump							
1	1250	(1), 2-1/4" or (2), 1-1/2"	69 88	143	150	(3), 50'	20' of 6"
2	875	(1), 2" or (2), 1-3/8"	55 61	194	200	or	
3	625	(1), 1-1/2" 2-1/4"	88 69	245	250	(3), 100'	
4	1250	or (2), 1-1/2"	88	158	165	and (1), 50'  Siamesed	
1500 GPM Fire Pump							
1	1500	(2), 1-3/4" or (3), 1-1/2"	68 57	142	150	(3), 50'	20' of
2	1050	(1), 2" or (2), 1-1/2"	78 62	194	200	or	6" Min
3	750	(1), 1-3/4" or (2), 1-1/4"	68 66	245	250	(3), 100' and (1), 50'	or (2) 20' of
4	1500	(2), 1-3/4" or (3), 1-1/2"	68 57	157	165	Siamesed	6" Max

Min. discharge pressures listed above are for pumps operating with full 10' static suction lift. These pressures must be increased by 1 PSI for each 2.3 ft. less than 10' of lift.

**TABLE NO. 1**  
**NFPA 1901 TEST**

Class A							
TEST No.	GPM	Recom- mended Nozzles	Min. Nozzle Press. PSI	Min. Disch. Press. PSI	Min. Net Pump Press. PSI	Disch. Lines	Suction Hose
1750 GPM Fire Pump							
1	1750	(2), 2" or	55	143	150	(4), 50'	(2) 20' of 6"
2	1225	(3), 1-1/2" (2), 1-5/8" or	76 61	194	200	or	
3	875	(2), 1-1/2" or	84 79	245	250	(4), 100'	
4	1750	(3), 1-1/2" (1), 2" or	55 61	158	165		
2000 GPM Fire Pump							
1	2000	(2), 2" or	71	147	150	(4), 50'	(2) 20' of 6"
2	1400	(4), 1-1/2" (2), 1-3/4" or	57 60	199	200	or	
3	1000	(3), 1-1/2" (1), 2" or	49 71	249	250	(4), 100'	
4	2000	(2), 1-1/2" (2), 2" or	57 71	163	165		
2250 GPM Fire Pump							
1	2250	(2), 2-1/4"	56	144	150	(2 Groups) (3), 100'	20' of 8"
2	1575	(2), 1-3/4"	76	196	200	Siamesed	
3	1125	(2), 1-1/2"	72	246	250		
4	2250	(2), 2-1/4"	56	153	165		

Min. discharge pressures listed above are for pumps operating with full 10' static suction lift. These pressures must be increased by 1 PSI for each 2.3 ft. less than 10' of lift.

**TABLE NO. 1  
NFPA 1901 TEST**

Class A							
TEST No.	GPM	Recom- mended Nozzles	Min. Nozzle Press. PSI	Min. Disch. Press. PSI	Min. Net Pump Press. PSI	Disch. Lines	Suction Hose
2500 GPM Fire Pump							
1	2500	(2), 2-1/4"	69	144	150	(2 Groups) (3), 100'	20' of 8"
2	1750	(2), 2"	55	195	200	Siamesed	
3	1250	(2), 1-1/2"	88	246	250		
4	2500	(2), 2-1/4"	69	159	165		
3000 GPM Fire Pump							
1	3000	(2), 2-1/2"	65	146	150	(2 Groups) (3), 100'	(2) 20' of 8"
2	2100	(2), 2"	78	196	200	Siamesed	
3	1500	(2), 1-3/4"	68	247	250		
4	3000	(2), 2-1/2"	65	161	165		
3000 GPM Industrial Fire Pump							
1	3000	(2), 2-1/2"	65	96	100	(2 Groups) (3), 100'	(2) 20' of 8"
2	2100	(2), 2"	78	146	150	Siamesed	
3	1500	(2), 1-3/4"	68	197	200		
3500 GPM Industrial Fire Pump							
1	3500	(2), 2-1/2" and (1), 2-1/4"	45 44	95	100	(2 Groups) (3), 100' Siamesed	(2) 20' of 8"
2	2450	(2), 2-1/4"	67	146	150	& (2)-50'	
3	1750	(2), 2"	55	197	200	Siamesed	

Min. discharge pressures listed above are for pumps operating with full 10' static suction lift. These pressures must be increased by 1 PSI for each 2.3 ft. less than 10' of lift.

**IF FURTHER INFORMATION IS NEEDED, CALL W.S. DARLEY & CO. AT  
CHIPPEWA FALLS, WI. AT 800-634-7812 or 715-726-2650**

# ***DISCHARGE TABLES***



**TABLE NO. 2**  
**DISCHARGE FROM SMOOTH BORE NOZZLE**  
**Pressures measured by Pitot gage.**

Nozzle Pressure PSI	GALLONS PER MINUTE DELIVERED															
	1/4	3/8	1/2	5/8	3/4	7/8	1	1 1/8	1 1/4	1 3/8	1 1/2	1 5/8	1 3/4	2	2 1/4	2 1/2
5	4	9	16	26	37	50	66	84	103	125	149	175	203	266	337	415
6	4	10	18	28	41	55	72	92	113	137	163	192	223	292	369	455
7	4	11	19	30	44	59	78	99	122	148	176	207	241	315	399	491
8	5	11	21	32	47	64	84	106	131	158	188	222	257	336	427	525
9	5	12	22	34	50	67	89	112	139	168	200	235	273	357	452	557
10	6	13	23	36	53	71	93	118	146	177	211	248	288	376	477	587
12	6	15	25	40	58	78	102	130	160	194	231	271	315	412	522	643
14	7	15	27	43	63	84	110	140	173	210	249	293	340	445	564	695
16	7	16	29	46	67	90	118	150	185	224	267	313	364	475	603	743
18	7	17	31	49	71	95	125	159	196	237	283	332	386	504	640	788
20	8	18	33	51	75	101	132	167	206	250	298	350	407	532	674	830
22	8	19	34	54	79	105	139	175	216	263	313	367	427	557	707	871
24	8	20	36	56	82	110	145	183	226	275	327	384	446	582	739	909
26	9	21	37	59	85	115	151	191	235	286	340	400	464	606	769	947
28	9	21	39	61	89	119	157	198	244	297	353	415	481	629	799	982
30	10	22	40	63	92	123	162	205	253	307	365	429	498	651	826	1017
32	10	23	41	65	95	127	167	212	261	317	377	443	514	673	854	1050
34	11	23	43	67	98	131	172	218	269	327	389	457	530	693	880	1082
36	11	24	44	69	100	135	177	224	277	336	400	470	546	713	905	1114
38	11	25	45	71	103	138	182	231	285	345	411	483	561	733	930	1144
40	11	26	46	73	106	142	187	237	292	354	422	496	575	752	954	1174
42	11	26	47	74	109	146	192	243	299	363	432	508	589	770	978	1203
44	12	27	49	76	111	149	196	248	306	372	442	520	603	788	1000	1231
46	12	28	50	78	114	152	200	254	313	380	452	531	617	806	1021	1259
48	12	28	51	80	116	156	205	259	320	388	462	543	630	824	1043	1286
50	13	29	52	81	118	159	209	265	326	396	472	554	643	841	1065	1313
52	13	29	53	83	121	162	213	270	333	404	481	565	656	857	1087	1339
54	13	30	54	84	123	165	217	275	339	412	490	576	668	873	1108	1364
56	13	30	56	86	125	168	221	280	345	419	499	586	680	889	1129	1389
58	13	31	56	87	128	171	225	285	351	426	508	596	692	905	1149	1414
60	14	31	57	89	130	174	229	290	357	434	517	607	704	920	1168	1437
62	14	32	58	90	132	177	233	295	363	441	525	617	716	936	1187	1462
64	14	32	59	92	134	180	237	299	369	448	533	627	727	951	1206	1485
66	14	33	60	93	136	182	240	304	375	455	542	636	738	965	1224	1508
68	14	33	60	95	138	185	244	308	381	462	550	646	750	980	1242	1531
70	15	34	61	96	140	188	247	313	386	469	558	655	761	994	1260	1553
72	15	34	62	97	142	191	251	318	391	475	566	665	771	1008	1278	1575
74	15	35	63	99	144	193	254	322	397	482	574	674	782	1023	1296	1597
76	15	35	64	100	146	196	258	326	402	488	582	683	792	1036	1313	1618
78	15	36	65	101	148	198	261	330	407	494	589	692	803	1050	1330	1639

**TABLE NO. 2**  
**DISCHARGE FROM SMOOTH BORE NOZZLE**  
**Pressures measured by Pitot gage.**

Nozzle Pressure PSI	GALLONS PER MINUTE DELIVERED															
	1/4	3/8	1/2	5/8	3/4	7/8	1	1 1/8	1 1/4	1 3/8	1 1/2	1 5/8	1 3/4	2	2 1/4	2 1/2
80	16	36	66	103	150	201	264	335	413	500	596	700	813	1063	1347	1660
82	16	37	66	104	152	204	268	339	418	507	604	709	823	1076	1364	1681
84	16	37	67	105	154	206	271	343	423	513	611	718	833	1089	1380	1701
86	16	37	68	107	155	208	274	347	428	519	618	726	843	1102	1396	1721
88	16	38	69	108	157	211	277	351	433	525	626	735	853	1115	1412	1741
90	17	39	70	109	159	213	280	355	438	531	633	743	862	1128	1429	1761
92	17	39	70	110	161	215	283	359	443	537	640	751	872	1140	1445	1780
94	17	39	71	111	162	218	286	363	447	543	647	759	881	1152	1460	1800
96	17	40	72	113	164	220	289	367	452	549	654	767	890	1164	1476	1819
98	17	40	73	114	166	223	292	370	456	554	660	775	900	1176	1491	1838
100	18	41	73	115	168	225	295	374	461	560	667	783	909	1189	1506	1856
105	18	42	75	118	172	230	303	383	473	574	683	803	932	1218	1542	1902
110	19	43	77	121	176	236	310	392	484	588	699	822	954	1247	1579	1947
115	19	43	79	123	180	241	317	401	495	600	715	840	975	1275	1615	1991
120	19	44	80	126	183	246	324	410	505	613	730	858	996	1303	1649	2033
125	20	45	82	129	187	251	331	418	516	626	745	876	1016	1329	1683	2075
130	20	46	84	131	191	256	337	427	526	638	760	893	1036	1356	1717	2116
135	21	47	85	134	195	262	343	435	536	650	775	910	1056	1382	1750	2157
140	21	48	87	136	198	266	350	443	546	662	789	927	1076	1407	1780	2196
145	21	49	88	139	202	271	356	450	556	674	803	944	1095	1432	1812	2235
150	22	50	90	141	205	275	362	458	565	686	817	960	1114	1456	1843	2273

**TABLE NO. 3**  
**Approximate Discharge Flow From Different Nozzles**  
**At the end of Fifty Feet of Average, 2 1/2"**  
**Rubber Lined Fire Hose, for Various**  
**Pump Pressures with Discharge**  
**Valve Wide Open**

PUMP PRESSURE LBS	SIZE OF NOZZLE		& GALLONS PER MINUTE				
	3/4	7/8	1	1 1/8	1 1/4	1 3/8	1 1/2
30	90	119	153	187	217	250	282
40	103	137	177	216	253	290	327
50	115	153	198	242	284	325	367
60	126	168	216	265	311	357	402
70	136	182	234	287	337	385	435
80	145	194	250	308	361	414	465
90	154	206	265	325	383	437	492
100	162	217	280	343	405	462	520
110	171	228	295	360	425	485	549
120	179	239	307	377	444	510	572
130	186	249	318	392	462	530	596
140	193	258	330	407	480	549	618
150	200	267	341	421	497	567	
175	215	288	374	455	538		
200	230	309	395	486			
225	243	328	420				
250	257	345					

This table is offered as an aide in testing pump performance where facilities for accurate measurement of capacity are not available. The capacities given above are conservative, and will not vary more than 5% from actual capacities with any of the standard hose that might be used.

**TABLE NO. 4**

**Pump or Hydrant Pressure required to give Effective Nozzle Pressure through various Lengths of Rubber Lined Hose.**

Size of Hose		1		1 1/2		2		2 1/2				3		
Size of Nozzle		1/4	3/8	1/2	5/8	5/8	3/4	3/4	7/8	1	1 1/4	1 1/2	1 1/4	1 1/2
Nozzle Press PSI	Length of Hose Feet	PUMP OR HYDRANT PRESSURE - PSI												
40	100	45	43	48	60	42	50	44	46	51	64	88	51	62
	200	49	46	56	79	43	60	47	52	60	86	130	59	78
	400	58	51	73	118	46	79	53	62	79	129	212	75	110
	600	67	57	89	158	50	99	59	74	97	172		92	143
	800	76	62	106	196	53	119	65	85	116	215		108	176
	1000	85	68	122	235	56	138	72	96	134	258		124	208
	1500	108	72	142		64	187	87	118	181			165	
60	2000	130	96	204		72	226	103	151	227			205	
	100	67	64	72	89	63	73	65	69	75	95	132	76	92
	200	74	68	84	117	65	86	70	78	89	126	196	88	115
	400	87	76	107	173	69	112	79	94	116	188		111	161
	600	101	85	131	231	74	138	88	111	143	250		135	208
	800	114	93	153		79	164	98	127	170			158	
	1000	127	101	178		83	190	107	143	197			182	
80	1500	161	122	237		95	155	130	184	264				
	2000	195	142			106		153	225					
	100	88	85	96	117	83	99	87	92	99	126	175	101	103
	200	97	91	112	154	86	117	93	103	115	167		116	154
	400	115	102	143	228	92	154	105	125	148	249		147	
	600	132	112	174		98	191	117	147	181			178	
	800	150	123	206		104	228	129	167	214			209	
100	1000	167	134	238		110		141	191	247				
	1500	211	161			125		171	245					
	2000	254	188			140		201						
	100	111	107	120	146	104	123	108	115	125	157		126	152
	200	122	113	139	192	108	145	116	128	150	209		146	190
	400	143	127	177	284	115	190	130	154	200			184	
	600	165	140	217		123	235	145	180	250			223	
100	800	186	154	256		131		159	206					
	1000	208	167			138		174	232					
	1500	262	200			157		211						
	2000		234			175		253						

# ***REACH AND FRICTION LOSS TABLES***

Prepared by: RJG  
Approved by: WAH  
Revised by: WAH Via ECO 11337

Rev. A  
Date: 03/16/12  
Rev. Date: 02/19/2016  
1200643.doc

**TABLE NO. 5  
REACH OF FIRE STREAMS**

<b>Size of Nozzle</b>	<b>1/4"</b>	<b>3/8"</b>	<b>1/2"</b>	<b>5/8"</b>	<b>3/4"</b>	<b>7/8"</b>	<b>1"</b>	<b>1-1/4"</b>	<b>1-1/2"</b>
-----------------------	-------------	-------------	-------------	-------------	-------------	-------------	-----------	---------------	---------------

**NOZZLE  
PRESSURE      EFFECTIVE VERTICAL REACH - Feet**

40	30	35	40	50	59	62	64	65	69
60	35	40	45	60	74	77	79	84	87
80	38	42	48	65	81	85	89	94	96
100	40	44	50	68	84	89	94	100	102

**NOZZLE  
PRESSURE      MAXIMUM VERTICAL REACH - Feet**

40	60	65	70	75	78	79	80	80	80
60	70	75	85	95	105	106	108	110	110
80	78	83	95	105	117	125	132	140	140
100	80	88	100	110	122	135	145	155	155

**NOZZLE  
PRESSURE      EFFECTIVE HORIZONTAL REACH - Feet**

40	20	25	30	40	44	50	55	62	66
60	25	32	37	50	54	61	67	75	80
80	28	35	40	57	62	70	76	84	88
100	30	37	42	60	66	76	84	93	95

**NOZZLE  
PRESSURE      MAXIMUM HORIZONTAL REACH - Feet**

40	65	80	90	100	108	120	125	138	140
60	80	95	95	120	127	142	156	176	183
80	90	105	105	135	143	160	175	201	210
100	95	110	110	140	153	180	205	215	223

**TABLE NO. 6**  
**Friction Loss in Fire Hose**  
 Loss in PSI per 100 Feet of Hose

SIZE HOSE G.P.M.	LINEN HOSE			BEST RUBER LINED HOSE							
	1 1/2	2	2 1/2	3/4	1	1 1/2	2	2 1/2	3	3 1/2	(2)-2 1/2
10	1.0			13.5	3.5	0.5	.1				
15	2.2			29.0	7.2	1.0	0.3				
20	3.6			50.0	12.3	1.7	0.4				
25	5.5			75.0	18.5	2.6	0.6				
30	8.0	1.9		105.0	26.0	3.6	0.9				
40	13.0	3.2		180.0	44.0	6.1	1.5				
50	20.0	4.9	1.6		67.0	9.3	2.3				
60	28.0	7.0	2.2		96.0	13.5	3.3				
70	37.0	9.0	3.1		131.0	17.0	4.3				
80	47.0	11.5	3.8		171.0	23.0	5.6				
90	59.0	14.5	5.0		217.0	29.0	7.0				
100	72.0	17.5	5.9		268.0	33.0	8.4				
120		25.0	8.3		386.0	47.0	11.7				
140		34.0	11.0			62.0	16.0	5.2	2.0	0.9	1.4
160		43.0	14.0			78.0	20.0	6.6	2.6	1.2	1.9
180		53.0	17.7			97.0	25.0	8.3	3.2	1.5	2.3
200		63.0	21.5			121.0	30.6	10.1	3.9	1.8	2.8
220						146.0		12.0	4.6	2.1	3.3
240						173.0		14.1	5.4	2.5	3.9
260						204.0		16.4	6.3	2.9	4.5
280						237.0		18.7	7.2	3.3	5.2
300						272.0		21.2	8.2	3.7	5.9
320								23.8	9.3	4.2	6.6
340								26.9	10.5	4.7	7.4
360								30.0	11.5	5.2	8.3
380								33.0	12.8	5.8	9.2
400								36.2	14.1	6.3	10.1
425								40.8	15.7	7.0	11.3
450								45.2	17.5	7.9	12.5
475								50.0	19.3	8.7	13.8
500								55.0	21.2	9.5	15.2
525									23.2	10.5	16.6
550									25.2	11.4	18.1
575									27.5	12.4	19.6
600									29.9	13.4	21.2
650									34.5	15.5	24.8
700									39.5	17.7	28.3
750									45.0	20.1	32.2
800									50.5	22.7	36.2
850									56.5	25.4	40.7
900									63.0	28.2	45.2
1000									76.5	34.3	55.0

Prepared by: EAP  
 Revised by: JAF  
 Approved by: MCR

Losses in rough walled, rubber hose may be 50% higher than values given above.

**TABLE NO. 7**  
**Friction Loss in 15-year-old Steel Pipe**  
 Loss in PSI per 100 Feet of Pipe

PIPE SIZE G.P.M.	1/8	1/4	3/8	1/2	3/4	1	1 1/4	1 1/2	2	2 1/2	3	4	6	8
1	52.0	12.0	2.8	0.9										
2		45.0	10.0	3.2	4.0									
5			55.0	18.0	4.5	1.4	0.4							
10				64.0	16.0	5.0	1.3	0.6						
15				135.0	34.0	11.0	2.7	1.3	0.5					
20					59.0	18.0	4.7	2.2	0.8					
25					89.0	27.0	7.1	3.4	1.2					
30					125.0	39.0	10.0	4.7	1.7	0.6				
35						51.0	13.0	6.3	2.2	0.7				
40						66.0	17.0	8.0	2.9	0.9				
45						82.0	21.0	10.0	3.6	1.2				
50						99.0	26.0	12.0	4.3	1.4	0.6			
60						140.0	38.0	17.0	6.1	2.0	0.8			
70							49.0	23.0	8.0	2.7	1.1			
80							63.0	29.0	10.0	3.4	1.5			
90							78.0	36.0	13.0	4.3	1.8			
100							96.0	44.0	15.0	5.1	2.2	0.5		
125							144.0	66.0	24.0	7.8	3.3	0.8		
150								93.0	33.0	11.0	4.6	1.1		
175								125.0	44.0	15.0	6.1	1.5		
200									56.0	19.0	7.8	1.9		
250									84.0	28.0	12.0	2.9		
300									114.0	40.0	16.0	4.0	0.6	
350										53.0	22.0	5.4	0.8	
400										68.0	28.0	6.9	1.0	
450										84.0	35.0	8.6	1.2	
500										102.0	42.0	10.0	1.4	0.4
600											60.0	15.0	2.1	0.6
800												25.0	3.5	1
1000												37.0	5.2	1.3
1500													11.0	2.7
2000													19.0	4.7
2500													29.0	7.1
3000														10



**TABLE NO. 8**  
**Resistance of Fittings**  
**Equivalent Lengths of Straight Pipe - Feet**

PIPE SIZE	1/2	3/4	1	1 1/4	1 1/2	2	2 1/2	3	4	5	6	8
Gate Valve	0.4	0.6	0.8	1.1	1.4	1.8	2.2	2.8	4.1	5.3	6.7	9.4
Global Valve	3.0	4.5	6.0	8.5	10.5	14.0	17.0	22.0	32.0	42.0	53.0	75.0
Angle Valve	1.4	2.0	2.7	3.8	4.8	6.3	7.9	10.5	14.5	18.5	23.0	33.0
Std. Elbow	1.1	1.5	2.0	2.8	3.5	4.7	5.8	7.5	11.0	14.0	18.0	24.0
45 Elbow	0.6	0.8	1.0	1.4	1.6	2.1	2.5	3.1	4.2	5.2	6.3	8.5
Long Sweep EI Str Run Tee	0.5	0.8	1.0	1.4	1.7	2.3	2.8	3.7	5.3	7.0	9.0	12.5
Std. Tee Thru Side Outlet	2.1	2.9	3.9	5.5	6.9	9.1	11.6	14.8	21.0	27.0	34.0	49.0
Sudden Enlarg or contraction	1.8	2.5	3.2	4.2	5.0	6.5	7.5	9.5	13.0	16.0	19.0	25.0
Entrance to Pipe	1.0	1.3	1.6	2.2	2.6	3.3	3.9	4.9	6.5	8.2	10.0	13.0

**TABLE NO. 9**  
**To Convert Pounds per Square Inch to**  
**Feet Elevation of Water**

**2.308ft head = 1.0 psi**  
**1ft head = .433psi**

Feet	5	10	15	20	25	30	35	40	45	50	60	70	80	90
Pounds	2.2	4.3	6.5	8.7	11	13	15	17	20	22	26	30	35	39
<b>Feet</b>	<b>100</b>	<b>120</b>	<b>130</b>	<b>140</b>	<b>150</b>	<b>160</b>	<b>170</b>	<b>180</b>	<b>190</b>	<b>200</b>	<b>220</b>	<b>240</b>	<b>260</b>	<b>280</b>
<b>Pounds</b>	<b>43</b>	<b>52</b>	<b>56</b>	<b>61</b>	<b>65</b>	<b>69</b>	<b>74</b>	<b>78</b>	<b>82</b>	<b>87</b>	<b>95</b>	<b>104</b>	<b>113</b>	<b>121</b>
Feet	300	320	340	360	380	400	425	450	475	500	525	550	600	700
Pounds	130	139	147	156	165	173	184	195	206	217	227	238	260	303

**Table NO. 10**  
**American National Fire Hose Connection Screw Thread - NH**

Size of Hose	4-Mar	1	1 1/2	2 1/2	3	3 1/2	4	4 1/2	5	6	8
Thr'ds per inch	8	8	9	7.5	6	6	4	4	4	4	4
Thread Designation	0.75-8 NH	1-8 NH	1.5-9 NH	2.5-7.5 NH	3-6 NH	3.5-6 NH	4-4 NH	4.5-4 NH	5-4 NH	6-4 NH	8-4 NH
Max. O.D. Male	1.375	1.375	1.99	3.0686	3.6239	4.2439	5.0109	5.7609	6.26	7.025	9.05

Ref. NFPA 1963

Underwriters Nozzle Tip Thread: 2.1875 O.D. - 12 threads per inch.

**IF FURTHER INFORMATION IS NEEDED, CALL W.S. DARLEY & CO. AT**  
**CHIPPEWA FALLS, WI. AT 800-634-7812 or 715-726-2650**

Prepared by: EAP  
 Revised by: JAF  
 Approved by: MCR

# **Section 3**

## **Installation**



## ***INSTALLATION OF TYPE ZSP PTO DRIVEN Fire Pump***

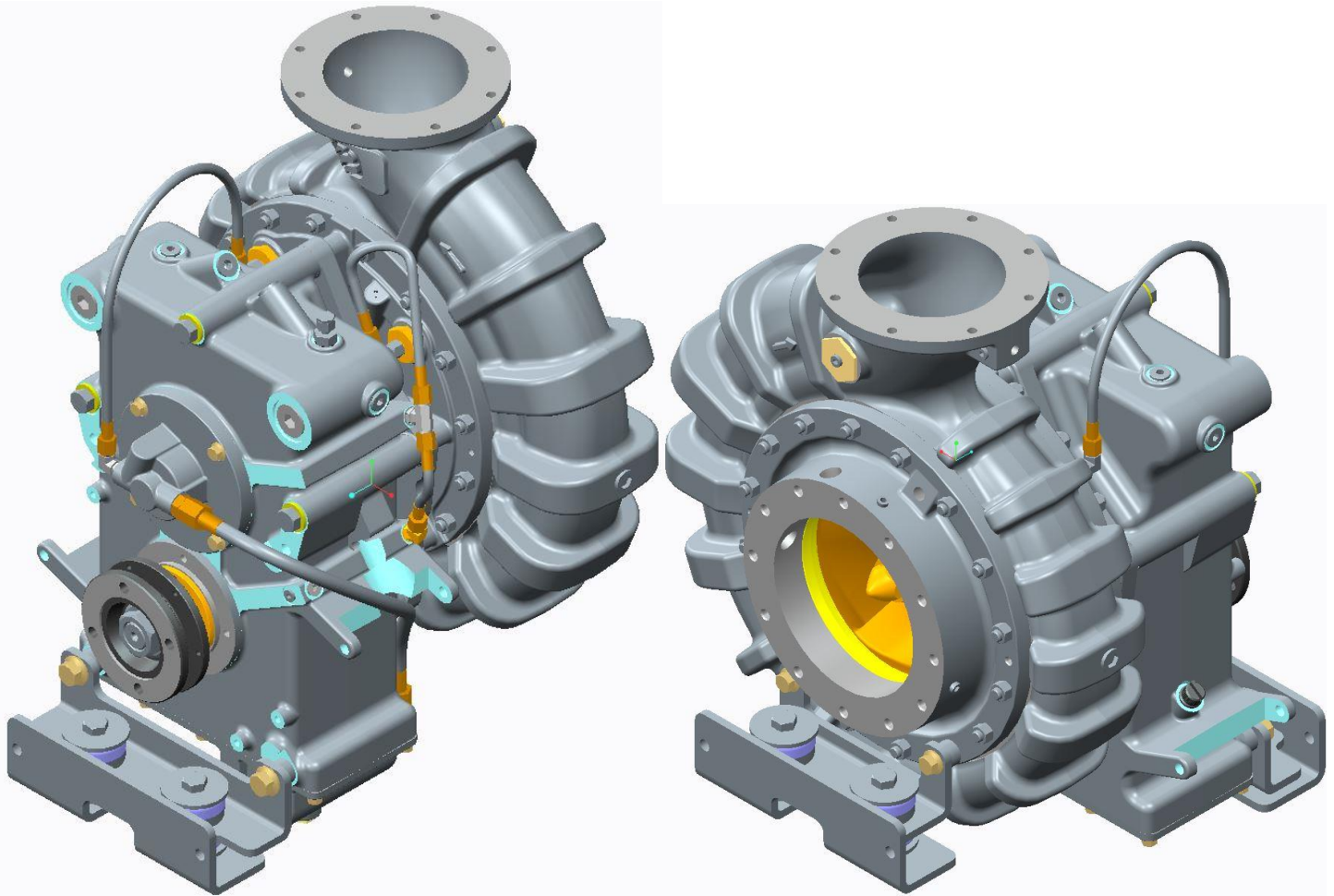

Prepared by: RJG  
Approved by: WAH  
Revised by: WAH VIA ECO 11337

Revision: A  
Original release date: 03/16/12  
Revision release date: 02/19/2016  
1201050.doc

## **Important**

### **⚠ WARNING**

Rotating shafts can be dangerous. Clothes, skin, hair, hands, etc. can become snagged or tangled, causing serious injury or death.

Do not work on a driveshaft or pump when the engine is running or without the wheels chocked.

### **⚠ WARNING**

Great care must be taken in the layout of pump drivelines. Interference and driveline vibration must be considered. An experienced installer with knowledge of driveline considerations, proper layout and recommended guidelines should be utilized as well as proper CAD systems for driveline layouts. Installation of the driveline should not occur until a proper analysis is performed by either a qualified driveline specialist or W.S. Darley. W.S. Darley utilizes, can distribute and can train qualified individuals to use the Allison Multiple Joint Driveline Analysis program.

W.S. Darley requires that Power Take Off (PTO) driven pumps have at most 500 radians per second<sup>2</sup> torsional vibration and at most 1000 radians per second<sup>2</sup> inertial drive torsional vibration, as calculated by the Allison Multiple Joint Driveline Analysis program, for a completed driveline installation. A completed driveline installation includes the entire multi-driveshaft assembly from the power source of the PTO output flange to the input flange of the PTO driven pump.

Failure to design and analyze a proper driveline layout could result in severe injury and damage to equipment, including but not limited to: the water pump, the water pump transmission, drive tubes, hanger bearings, u-joint crosses, gears, the rear differential, and the main truck transmission.

### **⚠ WARNING**



Exposed rotating drive-shafts should be guarded.

It is highly recommended by Darley to use safety rings around drive tubes. Especially near connecting u-joint crosses. Such safety rings would be sufficiently attached to the chassis frame and sufficiently strong enough to prevent a broken u-joint assembly from allowing a driveline to slide out from underneath the truck at high speeds while still rotating, causing severe personnel injury. Said safety rings would be larger than the drive tube OD and provide enough clearance for dynamic non-rotational movement of the drivelines through loaded and unloaded conditions, driving operations and where chassis flex may occur.

**U-Joints:**

- Universal joints must always be installed in pairs to transmit uniform rotary motion.
- The operating angles of each universal joint in the pair should be as close to equal as possible.
- The input and output shafts of each universal joint pair may be either parallel, or so located that the centerline of each shaft intersects the midpoint of the shaft connecting each universal joint (intersecting angles).
  - o This arrangement may be required if the coupling shaft between pump and PTO is relatively short, or the engine is mounted with its driveshaft horizontal. Refer to attached drawing DGM1301 for examples of parallel shaft and intersecting angle installations.
  - o DGM1301 shows a midship split shaft style pump, but the same installation recommendation/information applies to PTO's and PTO driven pumps.

***See the appendix of this portion of the manual for the Spicer Driveline Installation Guide (J3311-1-DSSP)***

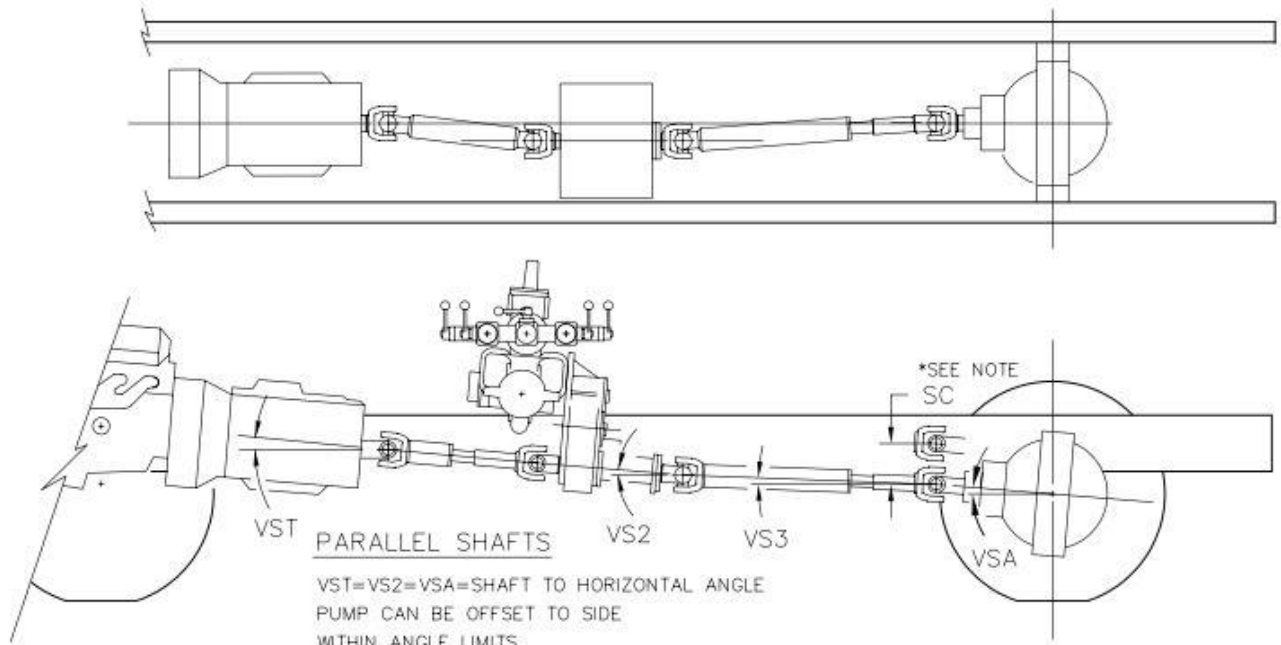

\*NOTE: ALLOW FOR SPRING COMPRESSION  
 WHEN SETTING ANGLES SO  
 OPERATING ANGLES ARE WITHIN  
 LIMITS

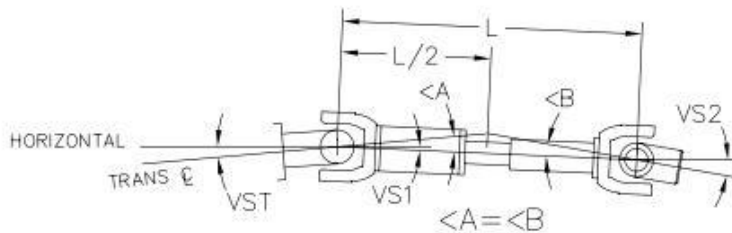
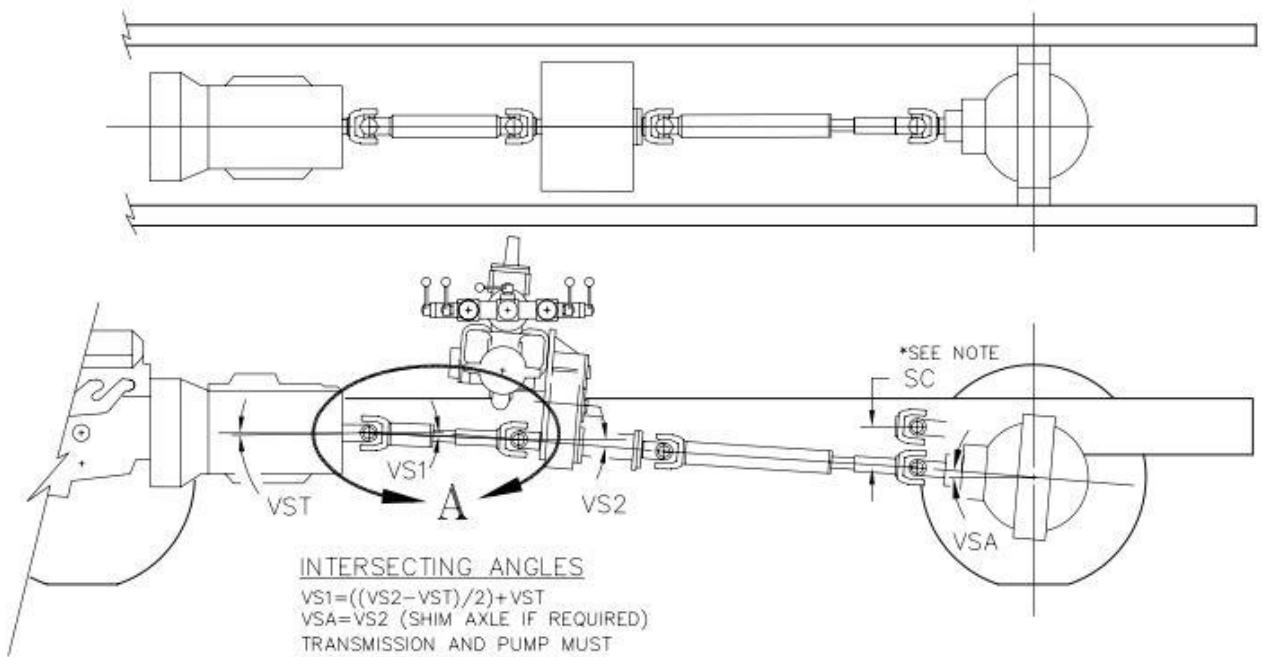

**DETAIL A**

(ANGLES VST, VS1, VS2 RELATIVE TO HORIZONTAL)

DCM1301 (LT40) 4-23-92

Prepared by: RJG  
 Approved by: WAH  
 Revised by: WAH VIA ECO 11337

Revision: A  
 Original release date: 03/16/12  
 Revision release date: 02/19/2016  
 1201050.doc

### Driveline and Mounting:

Determine the best location for the pump in your chassis. Allow adequate room for pump maintenance.

Place the pump/cross-member assembly on the chassis frame at the desired location. Be sure to set the suction manifold and transmission support brackets at a position allowing the best possible operating angle and driveline performance. This can be done by drilling frame rail mounting holes in a manner to rotate the entire pump/transmission assembly at an angle. As well up and down positioning is important.

Measure the vertical angle between the truck PTO shaft centerline and chassis frame (often 4°).

Suspend the pump so that the pump driveshaft centerline is as close as possible to being inline and parallel to the truck PTO shaft centerline. Example: If the truck PTO is at 4° with horizontal, the pump driveshaft should also be set at 4° with horizontal. This will insure that even if the PTO and pump are offset from each other, the universal joint operating angles will be equal.

Check to confirm that the pump shaft is parallel to the PTO shaft.

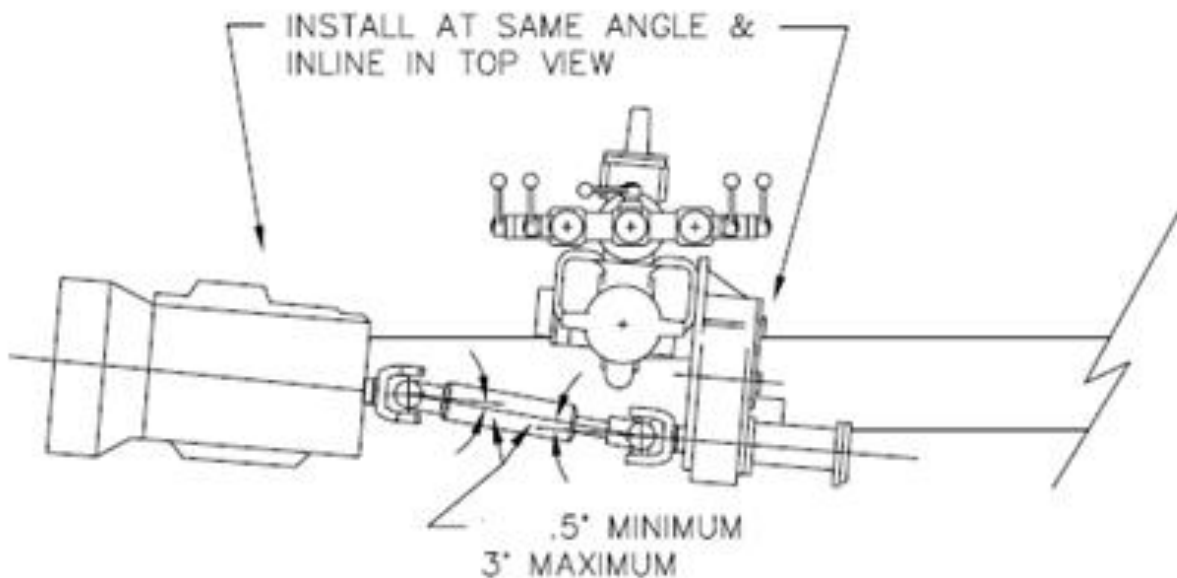

Place suction manifold mounting brackets into position as shown on detail drawing DGM2902 and securely clamp against side of frames. Attach brackets to the suction extensions with pipe U-bolts.

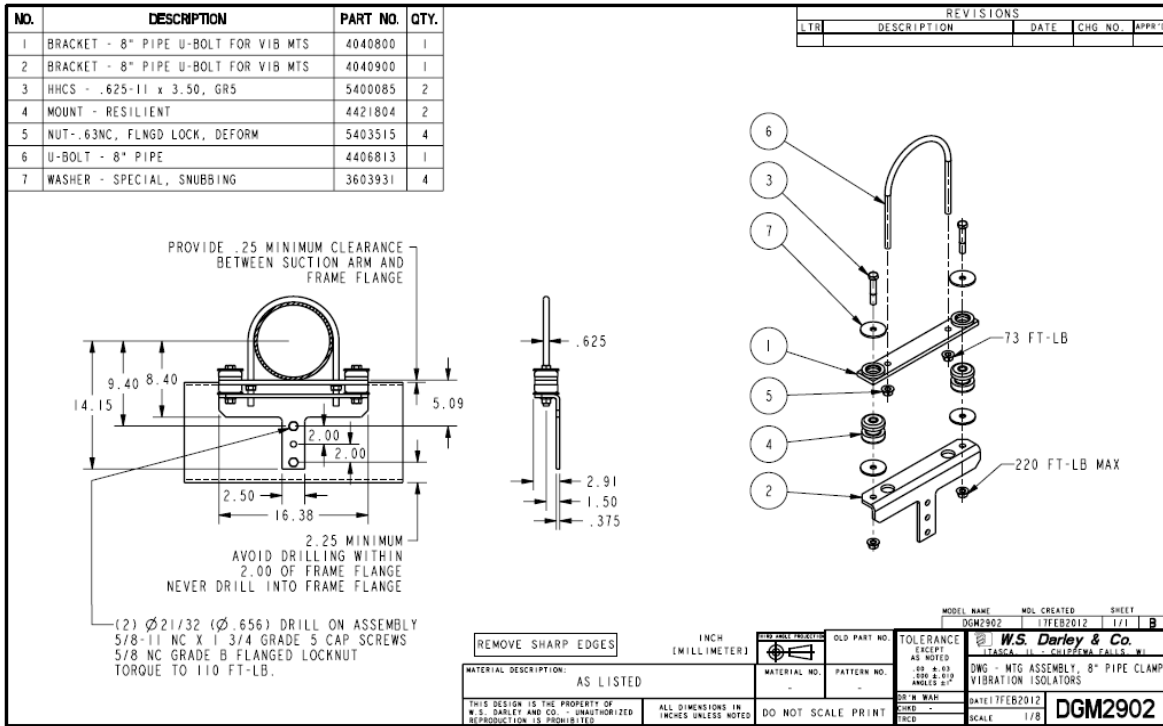

One of the two suction manifold brackets must be free to pivot as seen in drawing DGM1302. Choose one side of the frame or the other for the location of the pivot, the opposite must be rigidly secured with (2) 5/8" fasteners.

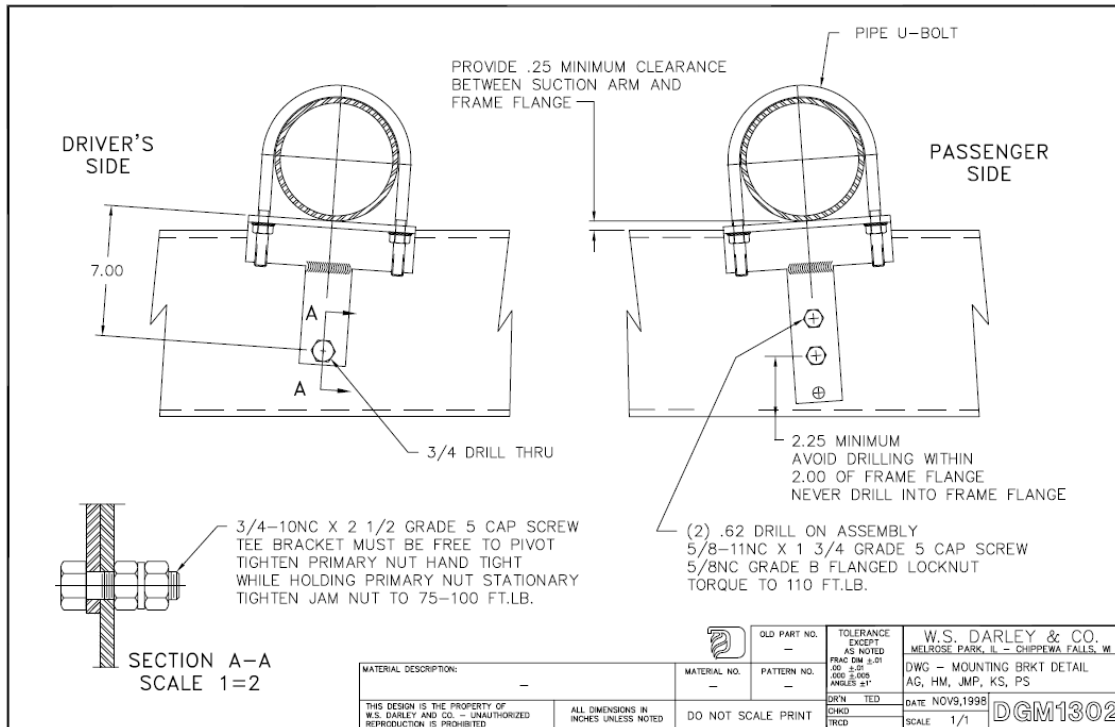

Drill holes through the side frames and attach the mounting brackets. Note both mounting brackets are designed to permit truck frame flex without imposing stress on pump extensions.

Prepared by: RJG  
 Approved by: WAH  
 Revised by: WAH VIA ECO 11337

Revision: A  
 Original release date: 03/16/12  
 Revision release date: 02/19/2016  
 1201050.doc



Reference drawing DGM2908 for the KM02102 and KM02103 bracket assembly locations on the ZSP.

NO.	DESCRIPTION	PART NO.	QTY.
1	KIT-MOUNTING, ZSF SUCTION HEAD	KM02102	1
2	KIT-MOUNTING, ZSP GEAR CASE	KM02103	1

REVISIONS				
LTR	DESCRIPTION	DATE	CHG NO.	APPR'D

**REFERENCE NOTES:**  
 1) REFER TO DRAWING DGM2905 FOR BILL OF MATERIAL KM02102.  
 2) REFER TO DRAWING DGM2906 FOR BILL OF MATERIAL KM02103.

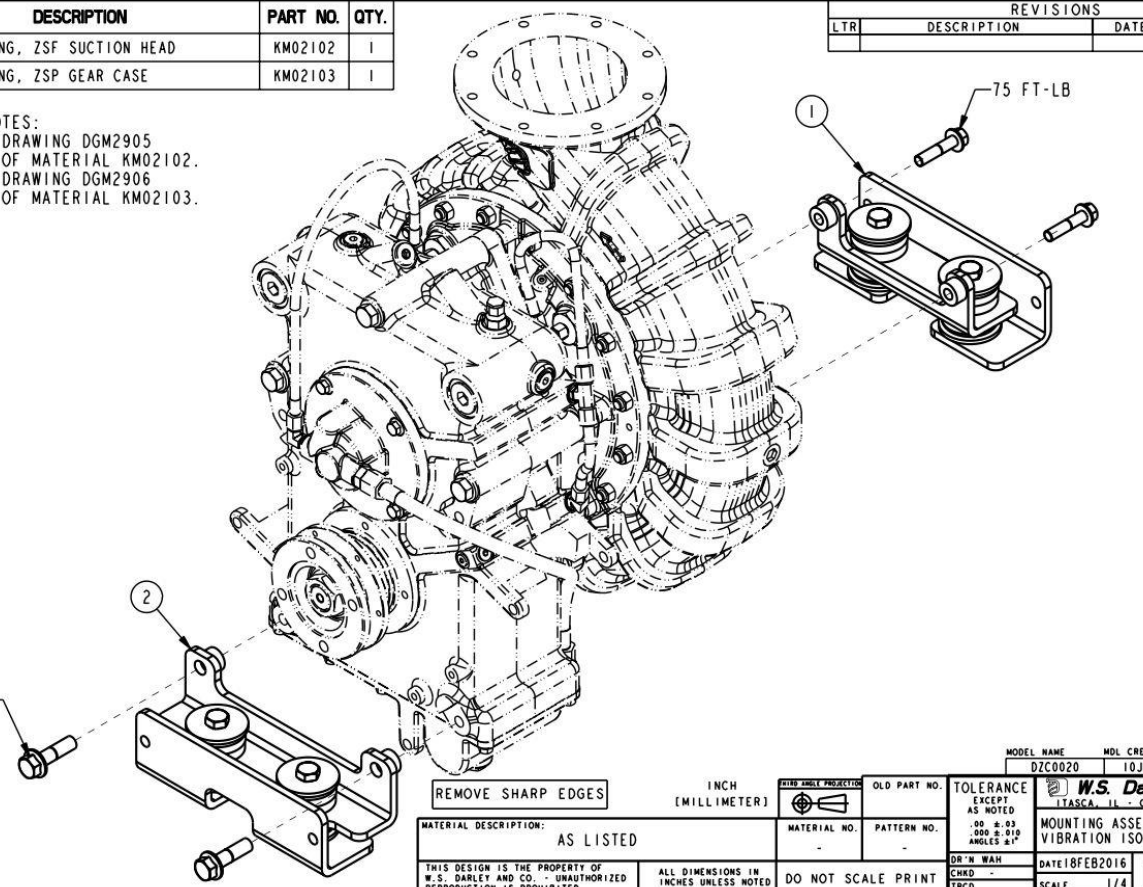

REMOVE SHARP EDGES

INCH (MILLIMETER)

MATERIAL DESCRIPTION: AS LISTED		OLD PART NO.	TOLERANCE EXCEPT AS NOTED - .00 ± .03 - .000 ± .010 ANGLES ±1°
THIS DESIGN IS THE PROPERTY OF W.S. DARLEY AND CO. - UNAUTHORIZED REPRODUCTION IS PROHIBITED		MATERIAL NO.	DR 'N WAH
ALL DIMENSIONS IN INCHES UNLESS NOTED		PATTERN NO.	CHKD -
DO NOT SCALE PRINT		DATE 18FEB2016	TRCD

MODEL NAME	MDL CREATED	SHEET
DZC0020	10JUL2014	1/1
<b>W.S. Darley &amp; Co.</b>		
ITASCA, IL - CHIPPEWA FALLS, WI		
MOUNTING ASSEMBLY, ZSP 2 GEAR VIBRATION ISOLATORS		
SCALE	1/4	<b>DGM2908</b>

Prepared by: RJG  
 Approved by: WAH  
 Revised by: WAH VIA ECO 11337

Revision: A  
 Original release date: 03/16/12  
 Revision release date: 02/19/2016  
 1201050.doc

Assembly KM02102, depicted by drawing DGM2905, is the vibration isolating mounting bracket that attaches to the pump's suction head.

NO.	DESCRIPTION	PART NO.	QTY.
1	BRACKET - ZSE SUCTION HEAD	4042100	1
2	BRACKET - ZSE SUCTION HEAD	4042200	1
3	HHCS - .625-11 X 4.00, GR5	5400119	2
4	HHCS - FLANGED, .500-13 X 2.25	5402872	2
5	MOUNT - RESILIENT	4421804	2
6	NUT - .63NC, FLNGD LOCK, DEFORM	5403515	2
7	WASHER - SPECIAL, SNUBBING	3603931	4

REVISIONS				
LTR	DESCRIPTION	DATE	CHG NO.	APP'D

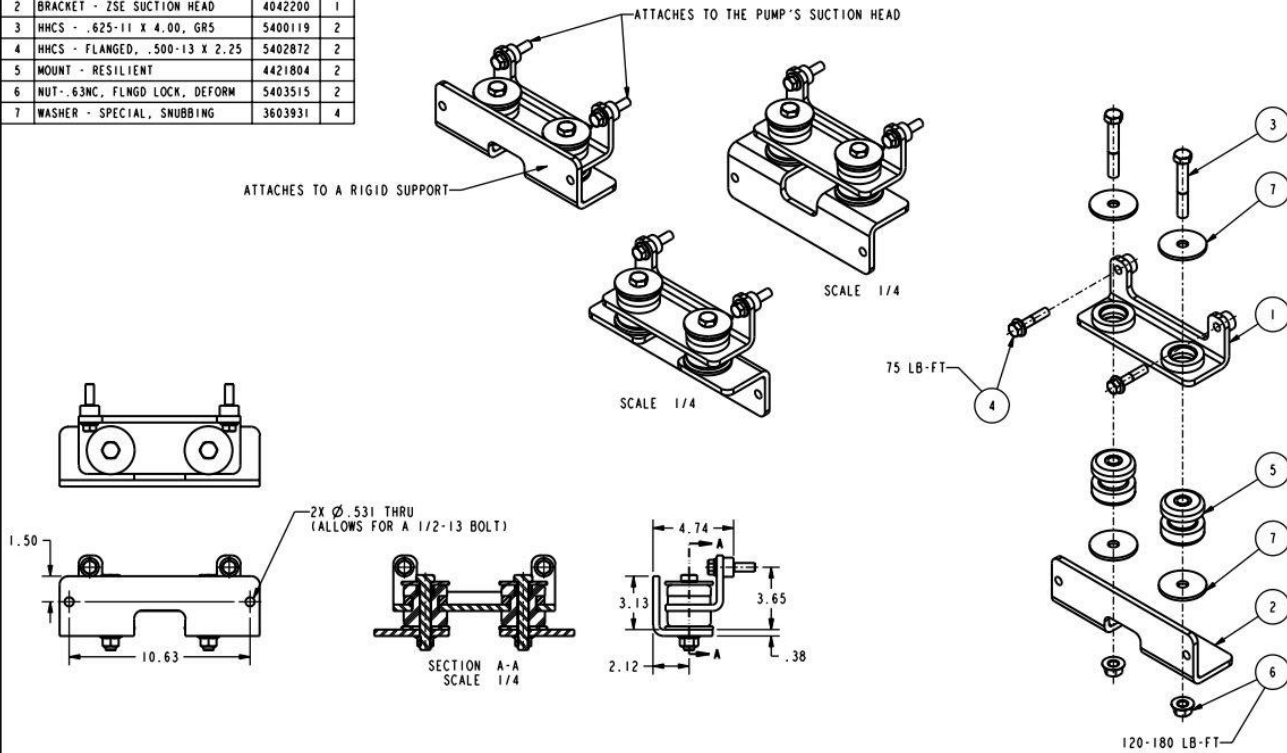

NOTES:

- 1) BEFORE INSTALLATION ON THE PUMP, TIGHTEN THE 5403515 NUTS TO 120-180 LB-FT. THEN, AFTER THIS ASSEMBLY HAS BEEN ATTACHED TO THE PUMP AND THE PUMP HAS BEEN ATTACHED TO THE ENGINE OR THE ADAPTER PLATE MOUNTING KIT HAS BEEN RIGIDLY MOUNTED, THE 4042200 BRACKET CAN BE LOCATED TO A RIGID FRAME SUPPORT.
- 2) THE 4042200 BRACKET CAN BE WELDED OR BOLTED TO SECURE IT TO A RIGID FRAME SUPPORT.
- 3) THE 4042200 BRACKET CAN BE ATTACHED TO THIS ASSEMBLY IN MANY DIFFERENT CONFIGURATIONS. THREE DIFFERENT CONFIGURATIONS ARE SHOWN ABOVE.
- 4) THIS ASSEMBLY IS ATTACHED TO THE PUMP SUCTION HEAD WITH THE 5402872 BOLTS.
- 5) THIS ASSEMBLY CAN BE ATTACHED IN ANY DESIRABLE ORIENTATION TO THE PUMP SUCTION HEAD.

REMOVE SHARP EDGES		INCH (MILLIMETER)		TOLERANCE EXCEPT AS NOTED - .00 ± .03 - .00 ± .04 - .00 ± .05		DATE 05JUN2014		SCALE 1/4	
MATERIAL DESCRIPTION: AS LISTED		MATERIAL NO.		PATTERN NO.		DATE 05JUN2014		SCALE 1/4	
THIS DESIGN IS THE PROPERTY OF W.S. DARLEY AND CO. - UNAUTHORIZED REPRODUCTION IS PROHIBITED		ALL DIMENSIONS IN INCHES UNLESS NOTED		DO NOT SCALE PRINT		DATE 05JUN2014		SCALE 1/4	

Prepared by: RJG  
 Approved by: WAH  
 Revised by: WAH VIA ECO 11337

Revision: A  
 Original release date: 03/16/12  
 Revision release date: 02/19/2016  
 1201050.doc

Assembly KM02103, depicted by drawing DGM2906, is the vibration isolating mounting bracket that attaches to the pump's gearbox.

NO.	DESCRIPTION	PART NO.	QTY.
1	BRACKET - ZSP GEAR CASE	4042101	1
2	BRACKET - ZSE SUCTION HEAD	4042200	1
3	HHCS - .625-11 X 4.00, GR5	5400119	2
4	HHCS - FLANGED, .625-11 X 2.25	5402874	2
5	MOUNT - RESILIENT	4421804	2
6	NUT - 63NC, FLNGD LOCK, DEFORM	5403515	2
7	WASHER - SPECIAL, SNUBBING	3603931	4

REVISIONS			
LTR	DESCRIPTION	DATE	CHG NO.

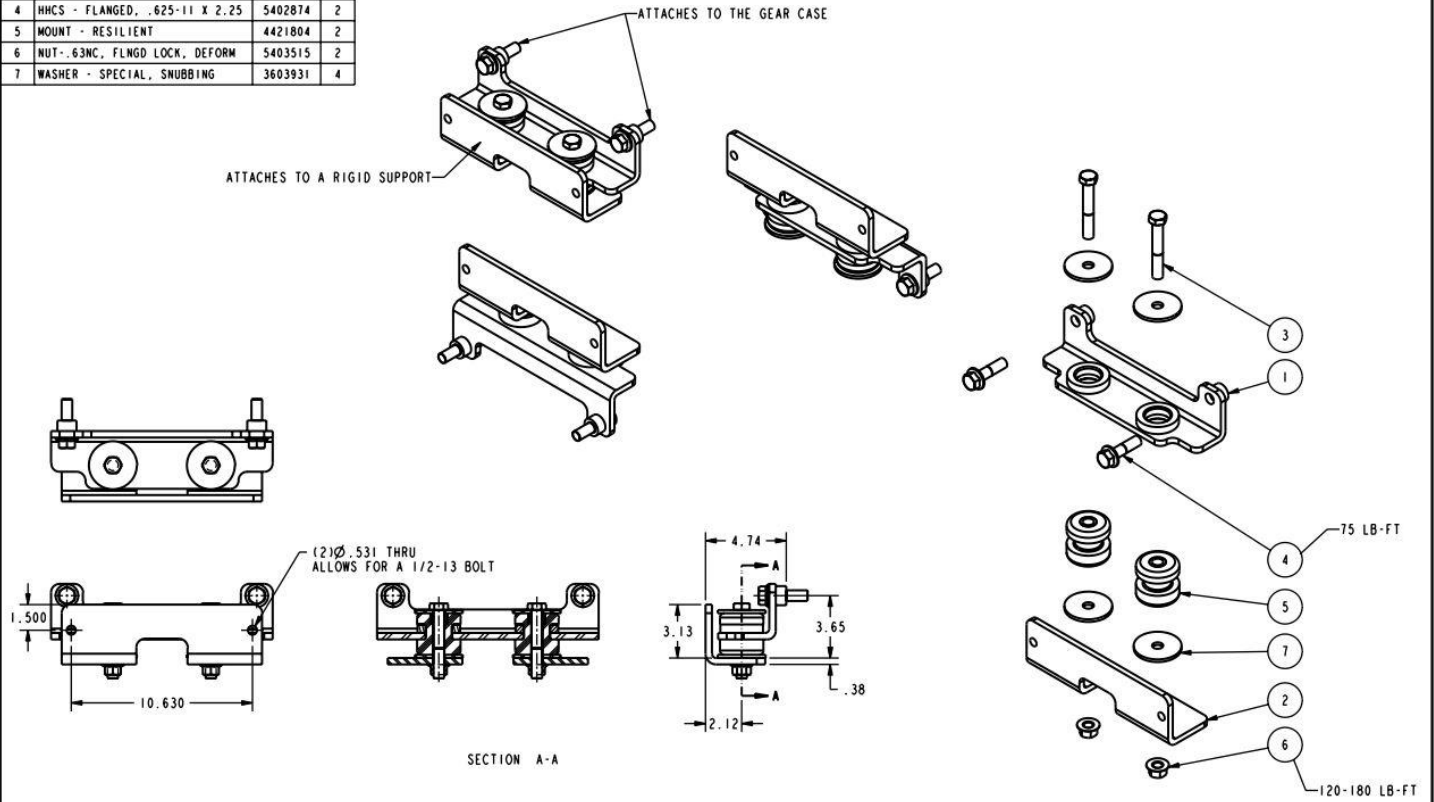

- NOTES:
- BEFORE INSTALLATION ON THE PUMP, TIGHTEN THE 5403515 NUTS TO 120-180 LB-FT. THEN, AFTER THIS ASSEMBLY HAS BEEN ATTACHED TO THE PUMP AND THE PUMP HAS BEEN ATTACHED TO THE ENGINE OR THE ADAPTER PLATE MOUNTING KIT HAS BEEN RIGIDLY MOUNTED, THE 4042200 BRACKET CAN BE WELDED OR BOLTED TO SECURE IT TO A RIGID FRAME SUPPORT.
  - THE 4042200 BRACKET CAN BE LOCATED TO A RIGID FRAME SUPPORT.
  - THE 4042200 BRACKET CAN BE ATTACHED TO THIS ASSEMBLY IN MANY DIFFERENT CONFIGURATIONS. THREE DIFFERENT CONFIGURATIONS ARE SHOWN ABOVE.
  - THIS ASSEMBLY IS ATTACHED TO THE PUMP SUCTION HEAD WITH THE 5402874 BOLTS.
  - THIS ASSEMBLY CAN BE ATTACHED IN ANY DESIRABLE ORIENTATION TO THE PUMP SUCTION HEAD.

REMOVE SHARP EDGES		INCH (MILLIMETER)		OLD PART NO.		TOLERANCE EXCEPT AS NOTED - .004-.005 - .006-.008 - .008-.010 - .010-.015		DATE 16-JUL-14		SHEET 1/1	
MATERIAL DESCRIPTION: AS LISTED				MATERIAL NO.		PATTERN NO.		DATE 16-JUL-14		SHEET 1/1	
THIS DESIGN IS THE PROPERTY OF W.S. DARLEY AND CO. UNAUTHORIZED REPRODUCTION IS PROHIBITED				ALL DIMENSIONS IN INCHES UNLESS NOTED				DO NOT SCALE PRINT		SCALE 1/4	
W.S. Darley & Co. STATESBORO, CT - CHIPPENAW FALLS, WI								KIT-MOUNTING, ZSP GEAR CASE VIBRATION ISOLATORS		DGM2906	

Prepared by: RJG  
 Approved by: WAH  
 Revised by: WAH VIA ECO 11337

Revision: A  
 Original release date: 03/16/12  
 Revision release date: 02/19/2016  
 1201050.doc

The 4042200 bracket is item 2 from both the KM02102 and KM02103 assemblies. 4042200 is the item that the customer will have to attach their own fabricated bracketing and cross members to for securing the ZSP back to the apparatus frame rails. If need be, customers can fabricate their own bracket to replace the 4042200 bracket from within the KM02103 or KM02103 assemblies.

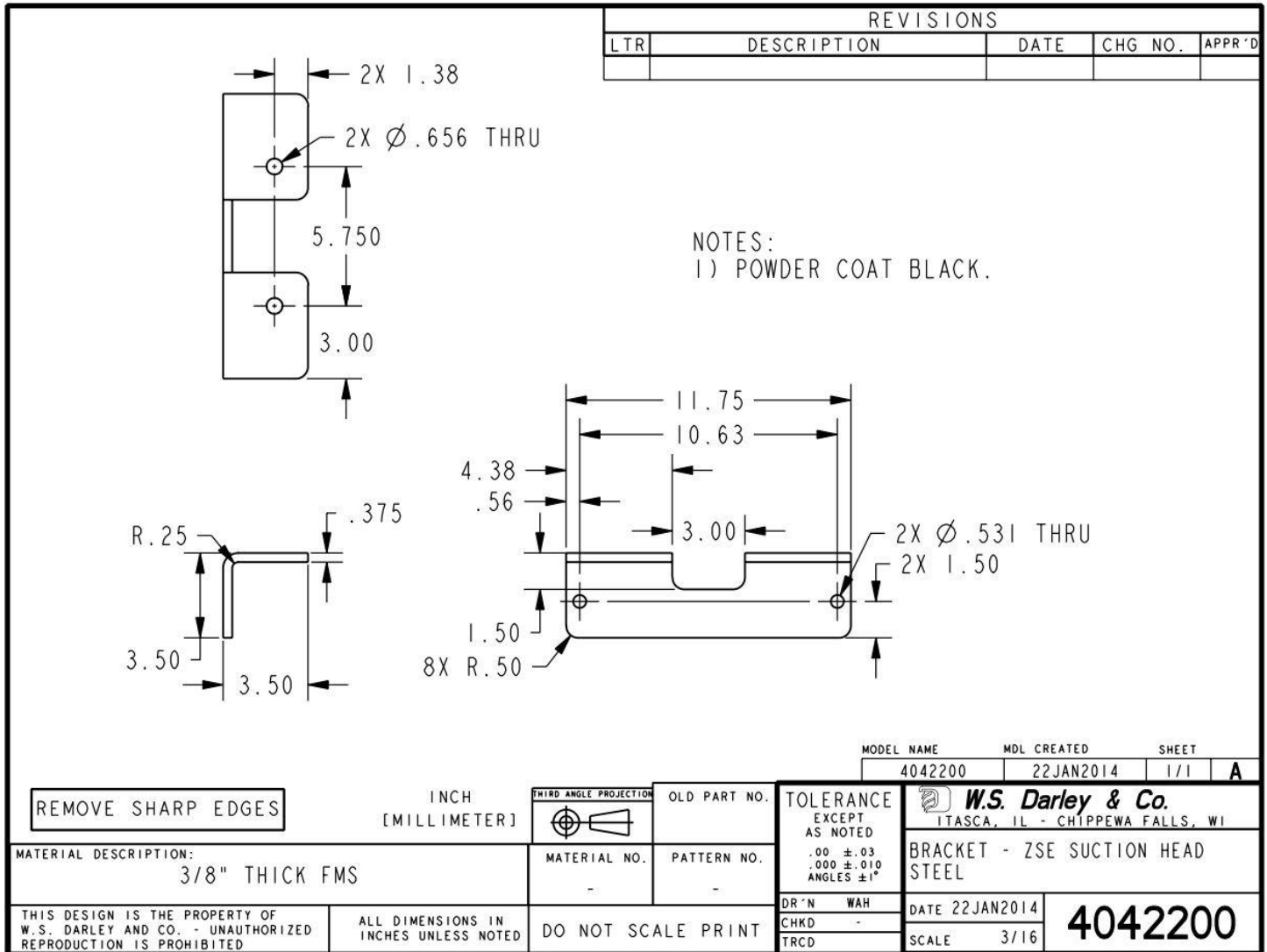

The 4042200 bracket is intended to be secured with 1/2" fasteners or welded back to the customers bracketing and cross members.

Prepared by: RJG  
Approved by: WAH  
Revised by: WAH VIA ECO 11337

Revision: A  
Original release date: 03/16/12  
Revision release date: 02/19/2016  
1201050.doc

Reference drawing 4421804 and 3603931 for vibration isolating mounts and washers for adapting the mounting brackets to attach to the customer's supplied cross member or bracketing.

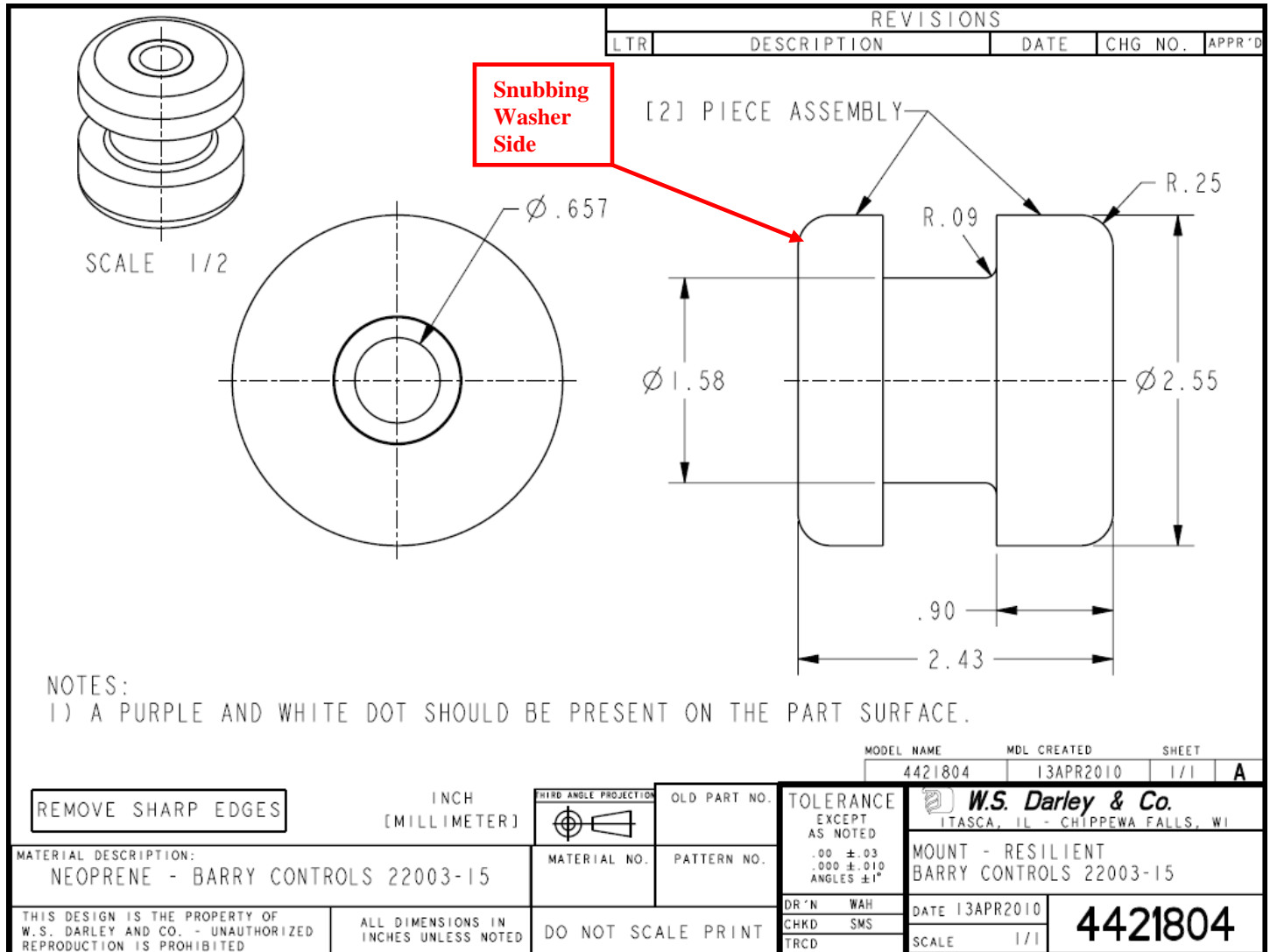

**IMPORTANT:** These rubber isolators are a two piece design. The loading on these isolation mounts is cantilevered in this application (i.e. the center of gravity of the transmission and pump assembly is not directly above the centerline of the rubber isolators, it is offset), therefore the snubbing washer (see 3603931 on the next page) should be on the core/bushing side of the rubber isolator (see below images). Therefore the snubbing washer should be on top of the smaller rubber section of the isolator, not the ring portion. So, for this application the stack-up from top to bottom should be as follows: bolt head, snubbing washer, core/bushing side of isolator, transmission mount bracket, ring portion of isolator, customer supplied cross member, nut or lock nut. Torsional loading should never be placed on the ring portion of the isolator.

Prepared by: RJG  
Approved by: WAH  
Revised by: WAH VIA ECO 11337

Revision: A  
Original release date: 03/16/12  
Revision release date: 02/19/2016  
1201050.doc

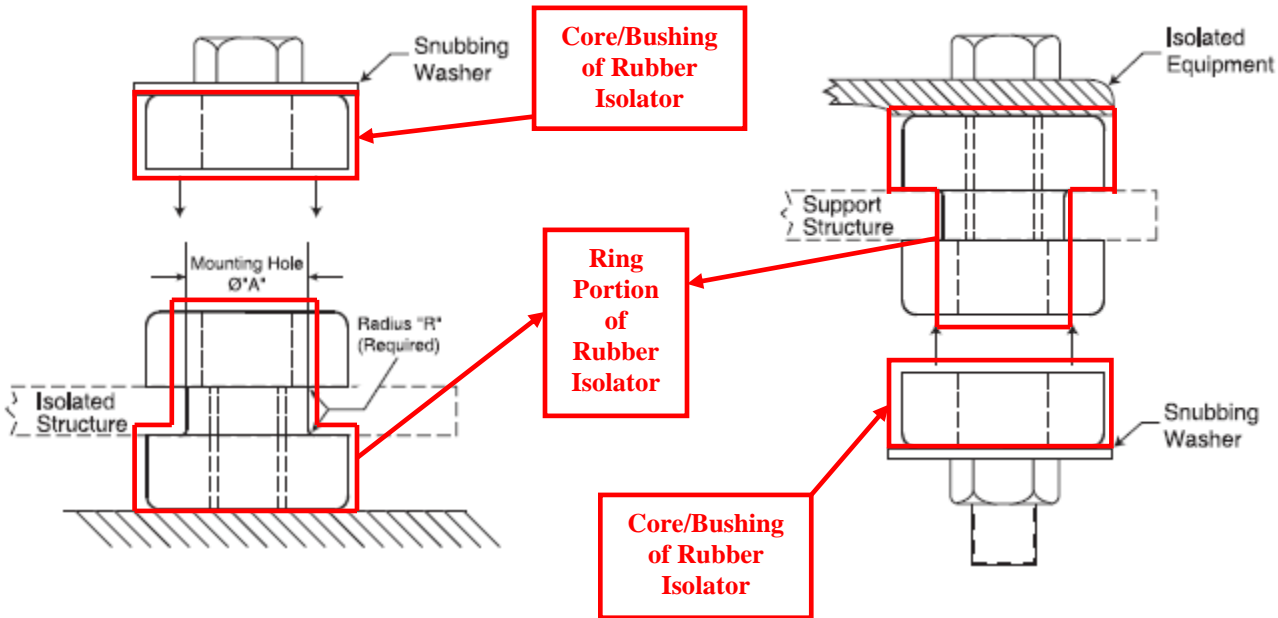

REVISIONS				
LTR	DESCRIPTION	DATE	CHG NO.	APPR'D

Ø2.81

Ø.657

.188

<p>REMOVE SHARP EDGES</p>	<p>INCH (MILLIMETER)</p>	<p>THIRD ANGLE PROJECTION</p>	<p>OLD PART NO.</p>	<p>TOLERANCE EXCEPT AS NOTED .00 ±.03 .000 ±.010 ANGLES ±1°</p>	<p><b>W.S. Darley &amp; Co.</b> ITASCA, IL - CHIPPEWA FALLS, WI</p>
<p>MATERIAL DESCRIPTION: BARRY CONTROLS 9810145-03804</p>		<p>MATERIAL NO.</p>	<p>PATTERN NO.</p>	<p>DR'N WAH CHKD SMS TRCD</p>	<p>WASHER - SPECIAL, SNUBBING BARRY CONTROLS 9810145-03804</p>
<p>THIS DESIGN IS THE PROPERTY OF W.S. DARLEY AND CO. - UNAUTHORIZED REPRODUCTION IS PROHIBITED</p>		<p>ALL DIMENSIONS IN INCHES UNLESS NOTED</p>	<p>DO NOT SCALE PRINT</p>	<p>DATE 13APR2010 SCALE 1/1</p>	<p>3603931</p>

Prepared by: RJG  
 Approved by: WAH  
 Revised by: WAH VIA ECO 11337

Revision: A  
 Original release date: 03/16/12  
 Revision release date: 02/19/2016  
 1201050.doc

Drill holes through the apparatus frame rails and attach necessary mounting brackets and cross members. Note, the KM02102 and KM02103 mounting bracket assemblies are designed to permit truck frame flexing without imposing stress on the pump. The installed brackets must be free to pivot as shown in drawing DGM1302. Choose one side of the frame or the other for the location of the pivot, the opposite must be rigidly secured with (2) 5/8" fasteners.

Provide adequate support for all piping.

**Keep the following points in mind when positioning the pump and constructing the driveline.**

1. Do not exceed recommended universal joint operating angles. Complimentary shaft angles should be equal and as low as possible.
2. Do not exceed universal joint torque limitations.
3. Do not exceed driveshaft speed/length limitations.
4. It is recommended that yokes on each end of a drive shaft be in phase. When in phase the yoke lugs (ears) at each end are in line.
5. Use balanced driveline components to help prevent vibration and to extend the life of drive yokes and other components related to the drive line.

**Torque the universal joint bearing cap retaining bolts to the following Dana Spicer Recommendations:**

<b>U-BOLT</b>		<b>CAP &amp; BOLT</b>	
<b>SERIES</b>	<b>RECOMMENDED NUT TORQUE</b>	<b>SERIES</b>	<b>RECOMMENDED BOLT TORQUE</b>
1280	14-17 LB. FT	1650	77-103 LB. FT
1310	14-17 LB. FT	1850	110-147 LB. FT
1330	14-17 LB. FT	1850	110-147 LB. FT
1350	20-24 LB. FT	1910	110-147 LB. FT
1410	20-24 LB. FT	1950	271-362 LB. FT
1480	32-37 LB. FT	2010	102-118 LB. FT
1550	32-37 LB. FT	2050	744- 844 LB. FT
<b>BEARING STRAP</b>		2110	171-197 LB. FT
<b>SERIES</b>	<b>RECOMMENDED BOLT TORQUE</b>	2150	744- 844 LB. FT
SPL90	45-60 LB. FT	2210	260- 298 LB. FT
1210	13-18 LB. FT	<b>BEARING PLATE</b>	
1280	13-18 LB. FT	<b>SERIES</b>	<b>RECOMMENDED BOLT TORQUE</b>
1310	13-18 LB. FT	1610	26-35 LB. FT
1330	13-18 LB. FT	1710	38-48 LB. FT
1350	30-35 LB. FT	1760	38-48 LB. FT
1410	30-35 LB. FT	1810	38-48 LB. FT
1480	55-60 LB.FT	1880	60-70 LB.FT
1550	55-60 LB.FT	<p align="center"><b>New part kits with lockstraps available from Spicer after Spring 1994</b></p>	
1610	55-60 LB.FT		
1710	130-135 LB. FT		
1760	130-135 LB. FT		
1810	130-135 LB. FT	<b>SERIES</b>	<b>RECOMMEND BOLT TORQUE</b>
		1610	17-24 LB. FT
		1710	32-42 LB. FT
		1760	32-42 LB. FT
		1810	32-42 LB. FT
		1880	50-66 LB. FT



**WARNING:** Bearing strap retaining bolts must **NOT** be reused!  
**WARNING:** Self-locking bolts must **NOT** be reused!

Note: The Dana Spicer fastener torque recommendations are per Dana Spicer's literature # 3119-5 DSD 4/94.



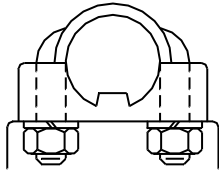

U-BOLT

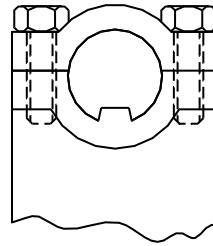

CAP &  
BOLT

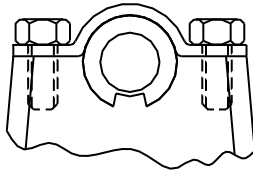

BEARING  
STRAP

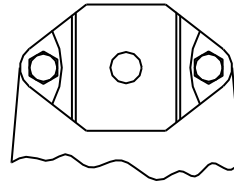

BEARING  
PLATE

Lubricate universal joint cross using a good quality E.P. (extreme pressure) grease meeting N.L.G.I. E.P. Grade 2 specifications. (Consult your local lubricant source for greases that meet this specification.)

**PRIMER CONNECTION:** For 12/24-volt electrically-clutched belt-driven priming pump installation, see drawings DVC0306 through DVC0309 found in “Section 4 - Pump Detail” of the “ZSP Installation, Operation, Maintenance, Repair and Troubleshooting Manual”.

**ENGINE COOLING/PUMP HEATER:** Two tapped openings in the pump suction head are provided for circulating engine coolant through the heater jacket/heat exchanger to prevent pump freezing in cold weather, and to aid in engine cooling in warm weather. Use no smaller than a 1/2” heater hose for this connection. See drawing DGS0400. An external heat exchanger should be added to aid in cooling the engine on units that do not have an internal heater jacket/heat exchanger in the suction head.

**PUMP SHIFT INSTALLATION:** For power shift installation, refer to DGS1100 for automatic transmission wiring details.

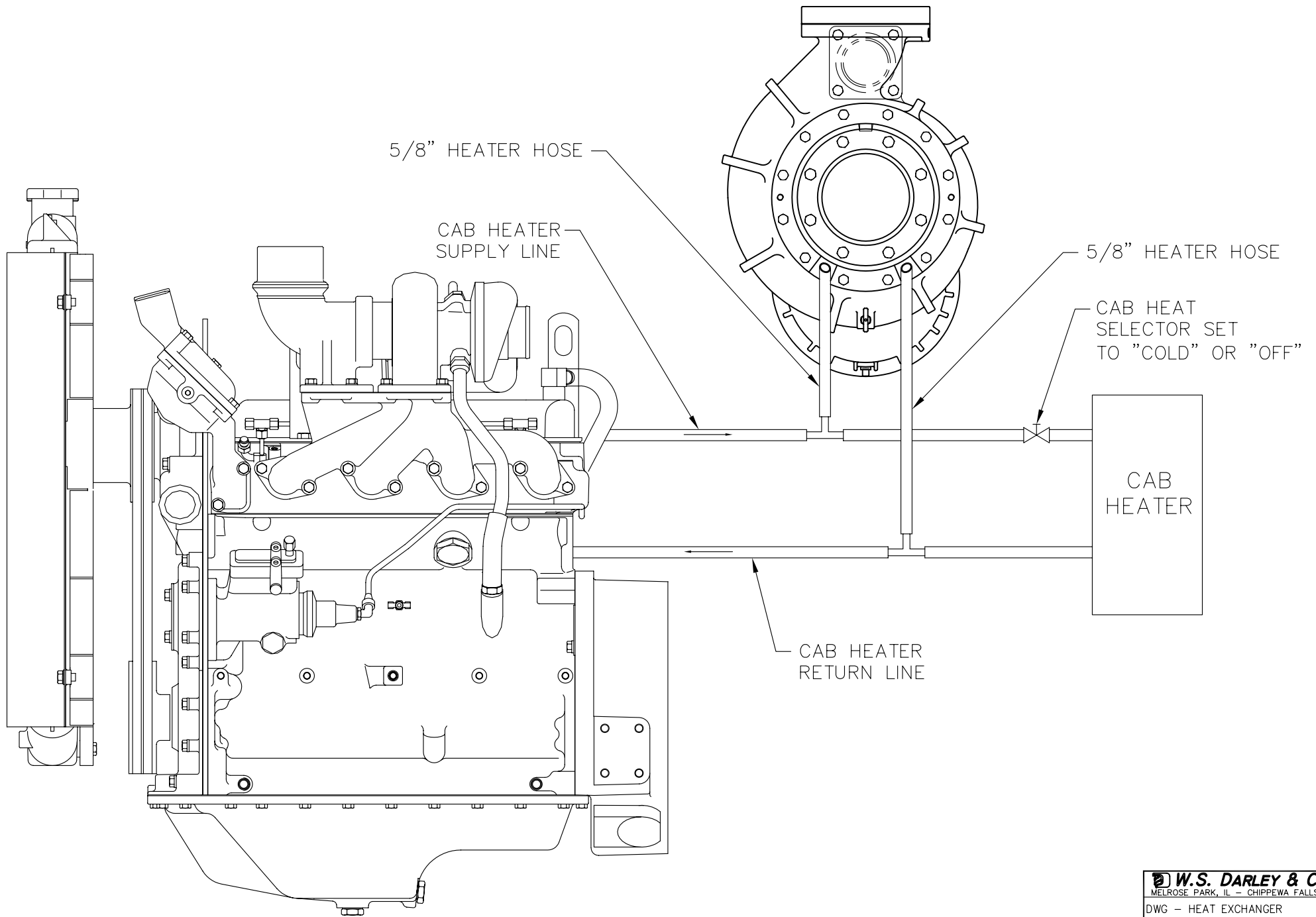

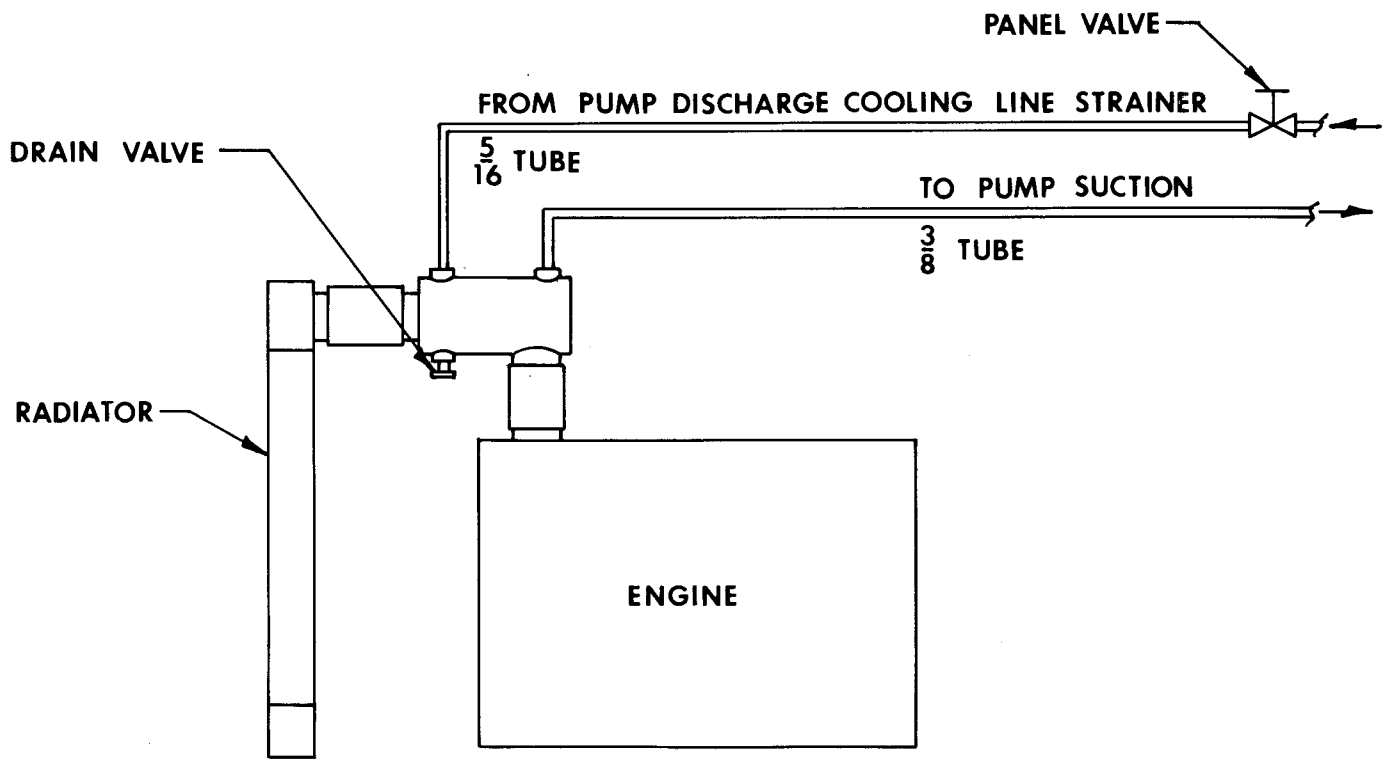

**R592 HEAT EXCHANGER**

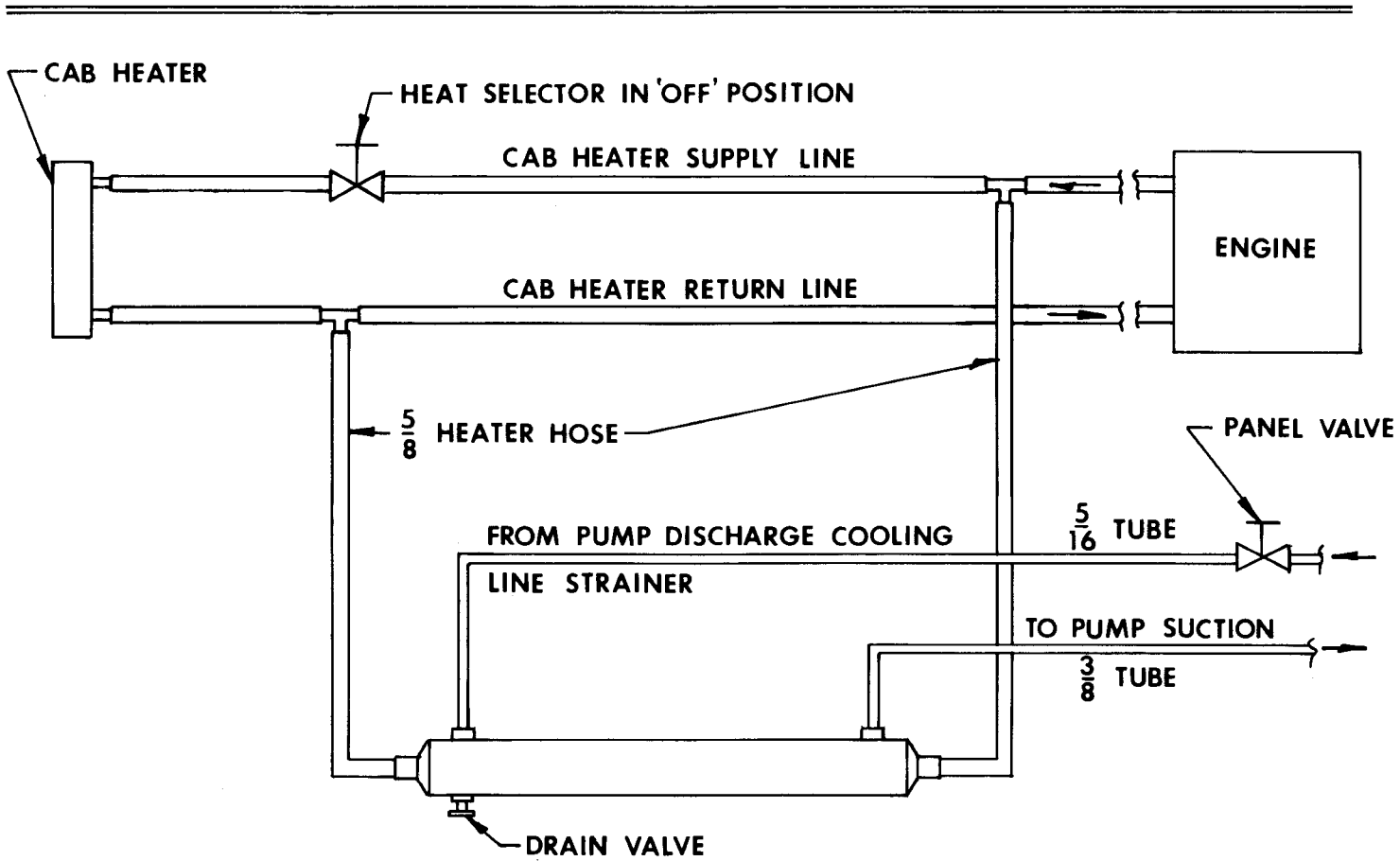

**F618 HEAT EXCHANGER**

REVISIONS

LTR	DESCRIPTION	DATE	CHG NO.	APPR'D
A	WAS: RED, PUMP PANEL "DANGER DO NOT OPEN THROTTLE"	20JAN00	00-11	DLW
B	ADDED LIGHT	20JAN00	00-11	DLW
C	WAS: GREEN, "WARNING: DO NOT OPEN THROTTLE UNLESS LIGHT IS ON"	20JAN00	00-11	DLW
D	ADDED NEWEST WIRE DESIGNATION #'s: 145, 143, 130; ADDED ALLISON E C U CONNECTOR #'s: 45, 43, 30;	6/23/08	2008-166	RJG

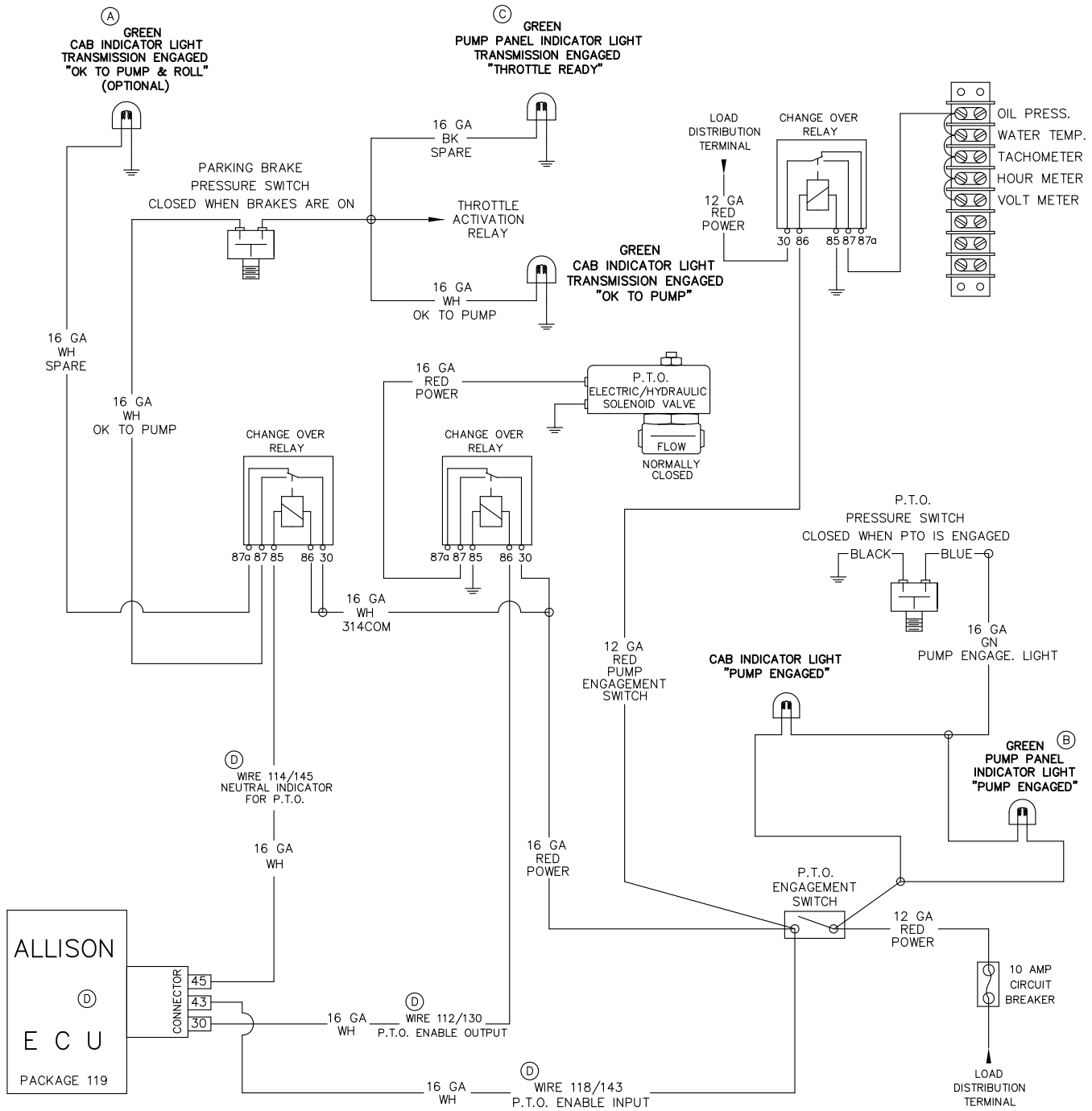

ELECTRICAL SCHEMATIC  
ALLISON WORLD TRANS.  
PTO/PUMP ENGAGEMENT



**W.S. Darley & Co.**  
APPARATUS DIVISION  
920 KURTH ROAD  
CHIPPEWA FALLS, WISCONSIN 54729  
1-715-726-2645

DWG BY SCHULTZ	SCALE SIZE A, 1:2	REV D
DATE 8-29-96	JOB NO.	DWG. NO. DGS1100

# SPICER<sup>®</sup>

DRIVETRAIN COMPONENTS



## DRIVELINE INSTALLATION



**J3311-1-DSSP  
AUGUST 2008**

**Supersedes  
J3311-1-HVTSS, Dated  
February 2005**



# SPICER<sup>®</sup>

Drivetrain Products

## General Safety Information

To prevent injury to yourself and /or damage to the equipment:

- Read carefully all owners manuals, service manuals, and/or other instructions.
- Always follow proper procedures and use proper tools and safety equipment.
- Be sure to receive proper training.
- Never work alone while under a vehicle or while repairing or maintaining equipment.
- Always use proper components in applications for which they are approved.
- Be sure to assemble components properly.
- Never use worn-out or damaged components.
- Always block any raised or moving device that may injure a person working on or under a vehicle.
- Never operate the controls of the power take-off or other driven equipment from any position that could result in getting caught in the moving machinery.



### **WARNING: ROTATING DRIVESHAFTS**

- Rotating auxiliary driveshafts are dangerous. You can snag clothes, skin, hair, hands, etc. This can cause serious injury or death.
- Do not go under the vehicle when the engine is running.
- Do not work on or near an exposed shaft when engine is running.
- Shut off engine before working on power take-off or driven equipment.
- Exposed rotating driveshafts must be guarded.



### **WARNING: GUARDING AUXILIARY DRIVESHAFTS**

We strongly recommend that a power take-off and a directly mounted pump be used to eliminate the auxiliary driveshaft whenever possible. If an auxiliary driveshaft is used and remains exposed after installation, it is the responsibility of the vehicle designer and PTO installer to install a guard.



### **WARNING: USING SET SCREWS**

Auxiliary driveshafts may be installed with either recessed or protruding set screws. If you choose a square head set screw, you should be aware that it will protrude above the hub of the yoke and may be a point where clothes, skin, hair, hands, etc. could be snagged. A socket head set screw, which may not protrude above the hub of the yoke, does not permit the same amount of torquing as does a square head set screw. Also a square head set screw, if used with a lock wire, will prevent loosening of the screw caused by vibration. Regardless of the choice made with respect to a set screw, an exposed rotating auxiliary driveshaft must be guarded.



### **WARNING: THIS SYMBOL WARNS OF POSSIBLE PERSONAL INJURY.**

---

Introduction ..... 1

Driveshaft Torque ..... 2

Common Causes of Vibrations ..... 3

Universal Joint Operating Angles ..... 5

Eliminating Compound Angle Induced Vibrations ..... 11

Multiple Shaft Installations ..... 13

Mounting a Midship-Mounted PTO, Pump, or Auxiliary Transmission ..... 16

Maximum Safe Operating Speed ..... 18

---

## Introduction

### This brochure is intended for:

- Installers who install Spicer driveshafts into an application where the transmission and axle are not in direct line with each other, causing the driveshaft universal joints to operate at an angle.
- Anyone experiencing vibration problems with their application or their vehicle that driveshaft assembly balancing will not correct.
- Truck Equipment Distributors who:
  - Re-work a chassis to change the wheel base.
  - Install a midship mounted power take-off or fire pump.
  - Mount any other PTO-driven device such as a blower, hydraulic pump, or hydraulic motor.

Universal joint failures, as a rule, are of a progressive nature, which, when they occur, generally accelerate rapidly resulting in a mass of melted trunnions and bearings.

Some recognizable signs of universal joint deterioration are:

1. Vibrations - Driver should report to maintenance.
2. Universal joint looseness - End play across bearings.
3. Universal joint discoloration due to excessive heat build-up.
4. Inability to purge all four trunnion seals when re-lubing universal joint.

Items 2) thru 4) should be checked at re-lube cycle and, if detected, reported to the maintenance supervisor for investigation.

Experience with universal joint failures has shown that a significant majority are related to lubricating film breakdown. This may be caused by a lack of lubricant, inadequate lube quality for the application, inadequate initial lubrication, or failure to lubricate properly and often enough.

Failures which are not the result of lubrication film breakdown are associated with the installation, angles and speeds, and manufacturing discrepancies.

Driveshaft failures through torque, fatigue, and bending are associated with overload, excessively high universal joint angles, and drive shaft lengths excessive for operating speeds.



## Driveshaft Torque

The following problems are usually a result of torque overloads:

- Twisted driveshaft tube
- Broken yoke shaft, slip yoke, tube yoke, flange yoke, end yoke
- Broken journal cross

### How much torque can be generated in your application?

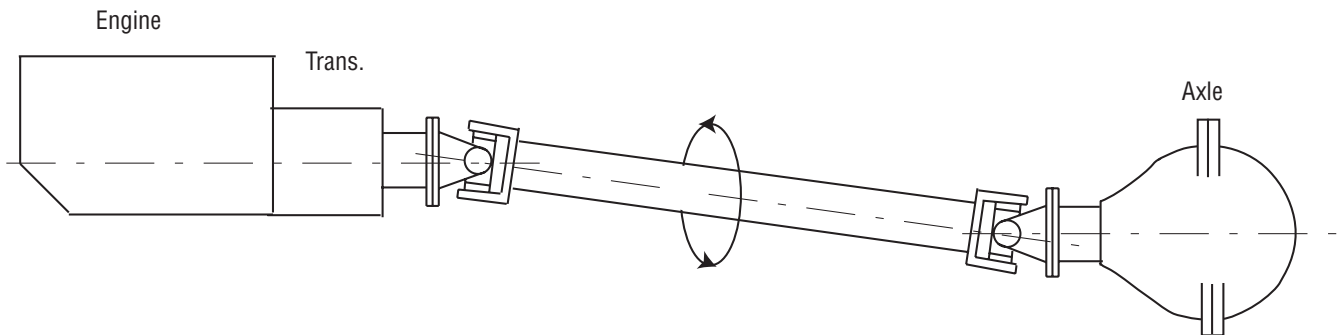

### How to Calculate Torque:

$$LGT = T \times TLGR \times TE \times SR \times TCR \times C$$

LGT = Maximum Driveshaft Low Gear Torque

T = Net Engine Torque or 95% of the Gross Engine Torque

TLGR = Transmission Low Gear Ratio (forward)\*

TE = Transmission Efficiency (automatic = 0.8; manual = 0.85)

SR = Torque Converter Stall Ratio (if applicable)

TCR = Transfer Case Ratio (if applicable)

C = Transfer Case Efficiency (if applicable, 0.95)

### How to Calculate Wheel Slip:

$$WST = (.71 \times W \times RR) / (11.4 \times AR)$$

WST = Wheel Slip Torque Applied to the Driveshaft

W = Axle Capacity (lbs)

RR = Tire Rolling Radius (in)

AR = Axle Ratio

### For On Road Applications

Relate the lesser of above to Spicer universal joint ratings. If your torque exceeds the Spicer rating for the universal joint used in your application, switch to a size with a rating compatible to your calculation. However, the series selected cannot be more than one series below the series called for by the LGT calculation.

### For Off Road or On-Off Road Applications

Use Low Gear Torque value only to verify or switch to a size with a rating compatible to your calculation.

## Common Causes of Vibrations

The three most common causes of driveshaft vibration are: Driveshaft Imbalance, Critical Speed, and Universal Joint Operating Angles.

### Driveshaft Imbalance

Eliminate the potential for balance problems before you undertake any other measures.

A driveshaft on a vehicle usually rotates at a higher rate of speed than the tire. For that reason, like tires, driveshafts should be balanced.

Any time you build or rework a driveshaft, make sure it is dynamically balanced at, 3000 RPM for Light Duty or 2500 RPM for Heavy Duty, to the following specifications:

Series	Specification
1310, 1330	.375 oz-in total at each end of shaft *
1350, 1410	.500 oz-in total at each end of shaft *
1480 - 1880	1.00 oz-in for each ten pounds of driveshaft weight divided proportionally at each end of shaft
* Passenger Car, Light Truck, Van, and SUV only. Industrial, Mobile Off-Highway, PTO, etc. same as 1480 - 1880.	

### Critical Speed

Every driveshaft has a critical speed. Critical speed is the point at which a rotating driveshaft begins to bow off its normal rotating centerline.

Driveshafts begin to vibrate as they approach critical speed. If they are operated at near critical speed for an extended period, they often fail. This can damage the vehicle and possibly injure persons nearby.

As a driveshaft fabricator or installer, you are responsible for checking the safe operating speed of any driveshaft you fabricate or specify into an application. Make sure it will not operate at a speed higher than Spicer's recommended safe operating speed. Use Spicer Calculator (P/N J 3253) to determine safe operating speed.

### Checking for a Possible Critical Speed Problem

Here is what you must do to make sure you won't have a critical speed problem:

- Determine the safe operating speed of the driveshaft you want to use in your application. Insert the tube diameter and center-to-center installed length of the shaft you want to use into a Spicer Safe Operating Speed Calculator (P/N. J3253). The calculator will tell you the safe operating speed of the shaft you have chosen.
- Determine the NORMAL and MAXIMUM POSSIBLE operating speed of the driveshaft.  
REMEMBER:
  - On vehicles with a standard transmission that have a 1:1 direct drive high gear and no overdrive, MAXIMUM POSSIBLE driveshaft RPM is the same as the maximum possible ENGINE RPM.
  - On vehicles that have an overdrive transmission, MAXIMUM POSSIBLE driveshaft RPM is higher than maximum possible ENGINE RPM.

## Maximum Possible Driveshaft RPM

To calculate the maximum possible driveshaft RPM in vehicles having an overdrive transmission, divide the maximum possible engine RPM by the overdrive ratio. (See examples below.)

Example 1:
Max. engine RPM: 2100
Overdrive ratio: .79
$2100 / .79 = 2658$ maximum possible driveshaft RPM

Example 2:
Max. engine RPM 6000
Overdrive ratio: .66
$6000 / .66 = 9091$ maximum possible driveshaft RPM

Compare the maximum possible driveshaft RPM with the safe operating speed determined from the Safe Operating Speed Calculator. If the maximum possible driveshaft RPM meets or exceeds the safe operating speed determined from the calculator, you must do whatever is required to raise the critical speed of the driveshaft you have chosen for the application.

### Sample Specification:

To specify a driveshaft for the application described in Example 1 above, compare the safe operating speed for the driveshaft selected with the maximum possible driveshaft RPM calculated (2658 RPM). Make sure the safe operating speed of the driveshaft is greater than 2658 RPM.

### Changing the Safe Operating Speed of a Driveshaft

A driveshaft's safe operating speed can be raised by increasing its tube diameter or by shortening the installed center-to-center length of the driveshaft. Changing the installed length of a driveshaft will require the use of multiple driveshafts with center bearings.

**Important:** The critical speed of an assembly can be affected by driveshaft imbalance, improper universal joint operating angles, or improperly phased driveshafts. (A properly phased driveshaft has the in-board yokes of the shaft in line with each other.) Each of the above items will tend to lower the true critical speed from the values shown on the calculator.

Since critical speed can ultimately cause driveshaft failure, it is extremely important to be very precise in all applications.

## Universal Joint Operating Angles

### Every Universal Joint that Operates at an Angle Creates a Vibration

Universal joint operating angles are probably the most common causes of driveline vibration in vehicles that have been reworked, or in vehicles that have had auxiliary equipment installed.

Universal joint operating angles are a primary source of problems contributing to:

- Vibrations
- Reduced universal joint life
- Problems with other drivetrain components that may include:
  - Transmission gear failures
  - Synchronizer failures
  - Differential problems
  - Premature seal failures in axles, transmissions, pumps, or blowers
  - Premature failure of gears, seals, and shafts in Power Take-Offs

When you rework a chassis or install a new driveshaft in a vehicle, make sure that you follow the basic rules that apply to universal joint operating angles:

**RULE 1:** UNIVERSAL JOINT OPERATING ANGLES AT EACH END OF A DRIVESHAFT SHOULD ALWAYS BE AT LEAST 1 DEGREE.

**RULE 2:** UNIVERSAL JOINT OPERATING ANGLES ON EACH END OF A DRIVESHAFT SHOULD ALWAYS BE EQUAL WITHIN 1 DEGREE OF EACH OTHER (ONE HALF DEGREE FOR MOTOR HOMES AND SHAFTS IN FRONT OF TRANSFER CASE OR AUXILIARY DEVICE).

**RULE 3:** FOR VIRTUAL VIBRATION FREE PERFORMANCE, UNIVERSAL JOINT OPERATING ANGLES SHOULD NOT BE LARGER THAN 3 DEGREES. IF THEY ARE, MAKE SURE THEY DO NOT EXCEED THE MAXIMUM RECOMMENDED ANGLES.

A universal joint operating angle is the angle that occurs at each end of a driveshaft when the output shaft of the transmission and driveshaft and the input shaft of the axle and driveshaft are not in line. (See Fig 1)

The connecting driveshaft operates with an angle at each universal joint. It is that angle that creates a vibration.

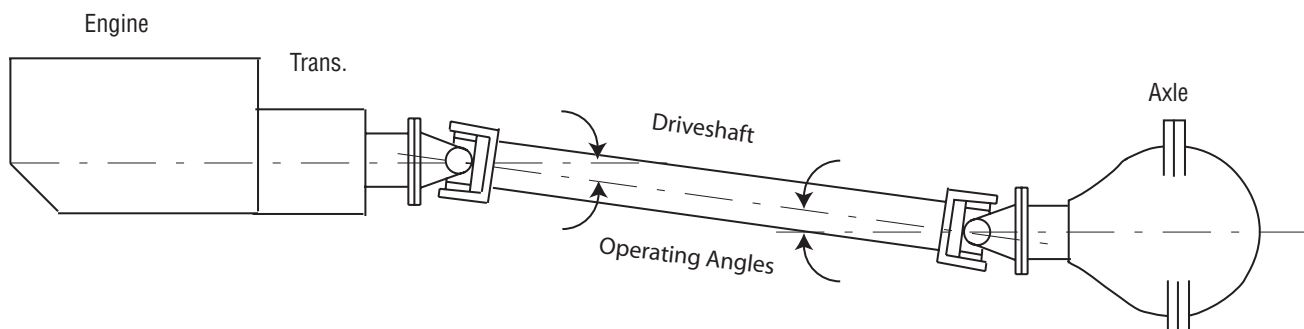
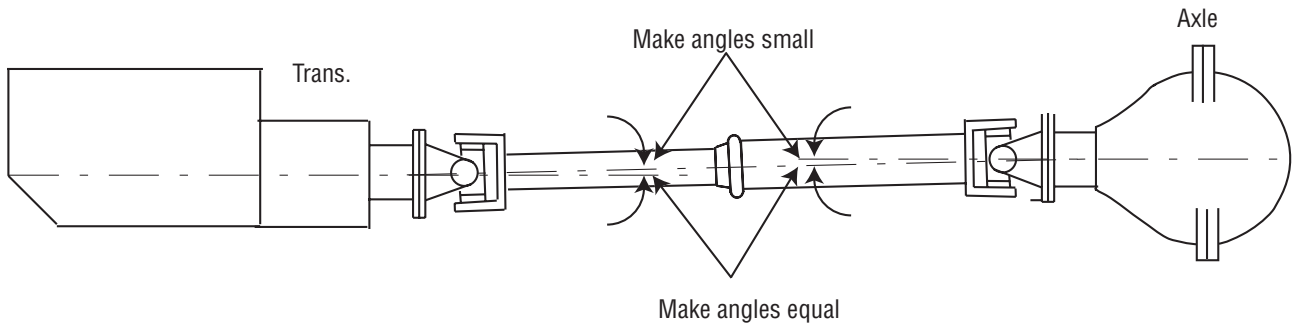

**Figure 1**

## Reducing and Canceling Vibration

A key point to remember about universal joint operating angles: To reduce the amount of vibration, the angles on each end of a driveshaft should always be **SMALL**.

To cancel an angle vibration, the universal joint operating angles need to be **EQUAL** within 1 degree at each end of a driveshaft. On motor home applications and auxiliary transmission installations, the tolerance is 1/2 degree. (See Fig 2)



**Figure 2**

## Single Plane and Compound Universal Joint Operating Angles

There are two types of universal joint operating angles: Single Plane and Compound.

### Single Plane

Single Plane angles occur when the transmission and axle components are in line when viewed from either the top or side, but not both.

Determining the universal joint operating angle in an application where the components are in line when viewed from the top, but not in line when viewed from the side, is as simple as measuring the slope of the components in the side view, and adding or subtracting those slopes to determine the angle. (See Fig. 3)

These angles should be **small** and **equal** within 1 degree.

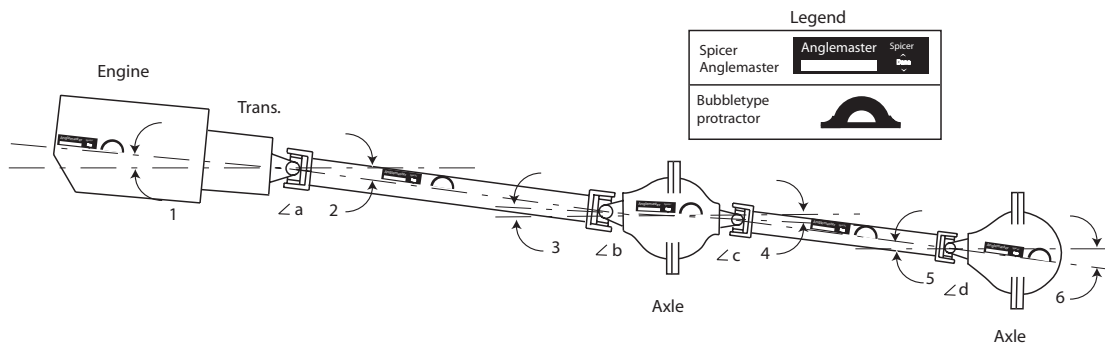

**Figure 3**

The most convenient way to determine universal joint angles in the side view is through the use of a Spicer Anglemaster™ or a bubble type protractor.

Using an Anglemaster or a bubble protractor, record inclination angles of drivetrain components. Set Anglemaster or protractor on machined surfaces of engine, transmission, axle, or on machined lugs of transmission and axle yoke(s).

**Note:** Universal joint angles can change significantly in a loaded situation. Therefore, check vehicle loaded and unloaded to achieve the accepted angle cancellation.

### Example:

Engine-Transmission Output	4°30' Down (1)
Main Driveshaft	7°00' Down (2)
Input 1st Rear Axle	4°00' Up (Input Shaft Nose Up) (3)
Output 1st Rear Axle	4°00' Down (4)
Inter-axle Shaft	7°00' Down (5)
Input 2nd Rear Axle	4°15' Up (Pinion Shaft Nose Up) (6)
Note: If inclination of driveshaft is opposite connecting component, add angles to obtain the universal joint operating angle.	
Angle a = (2) - (1) = 7°00' - 4°30' = 2°30' (2.50°)	
Angle b = (2) - (3) = 7°00' - 4°00' = 3°00' (3.00°)	
Angle c = (5) - (4) = 7°00' - 4°00' = 3°00' (3.00°)	
Angle d = (5) - (6) = 7°00' - 4°15' = 2°45' (2.75°)	

Determining the universal joint operating angles on a driveshaft that is straight when viewed from the side and offset when viewed from the top requires the use of a special chart (See Angle Chart). In this type of application, the centerlines of the connected components **must be parallel** when viewed from the top as shown. These angles also should be **small** and **equal** within 1 degree. (See Fig. 4)

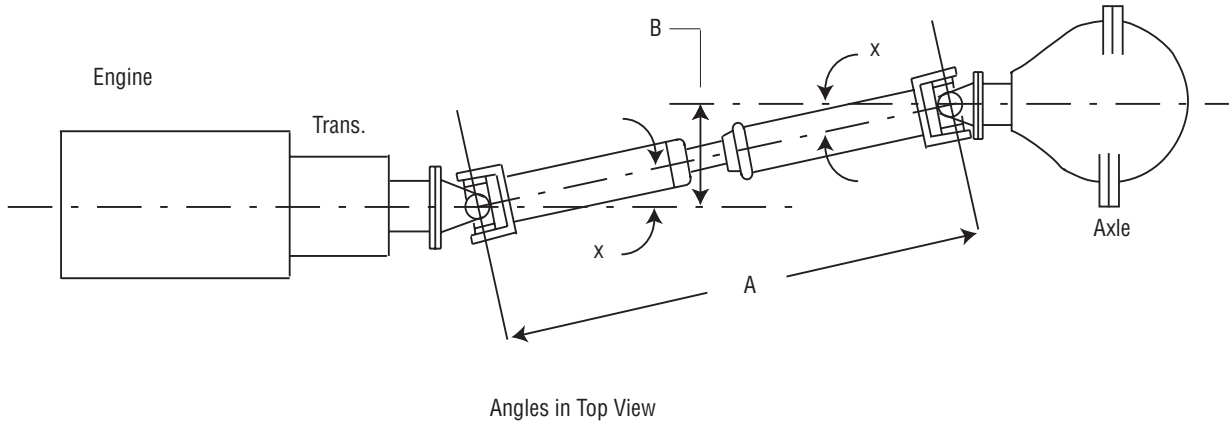

**Figure 4**

Measure dimensions "A" and "B" shown in figure 4. Use the instructions in the angle chart below to determine the size of the angle. Look at the Angle Chart and note that the smaller the offset, the smaller the resultant angle.

To reduce the possibility of vibration, keep any offset between connected points to a minimum.

There are two things you can do to always make sure Single Plane angles are SMALL and EQUAL: Make sure the transmission and axle are mounted so their centerlines are parallel when viewed from both the side and the top. Make sure the offset between them is small in both views.

## ANGLE CHART

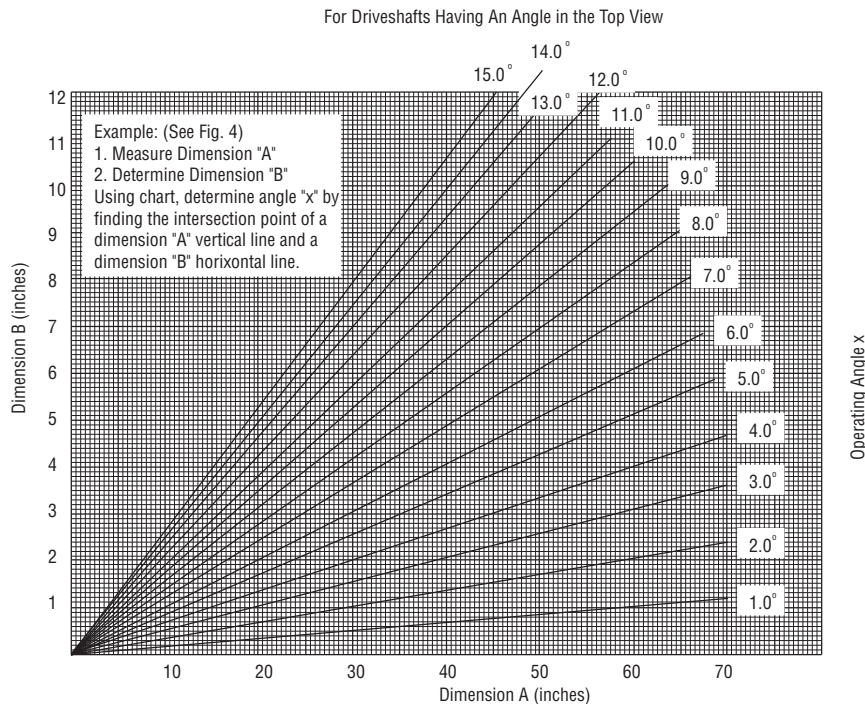

## Compound Angles

Compound universal joint operating angles occur when the transmission and axle are not in line when viewed from BOTH the top and side. Their centerlines, however, are parallel in both views. (See Fig. 5)

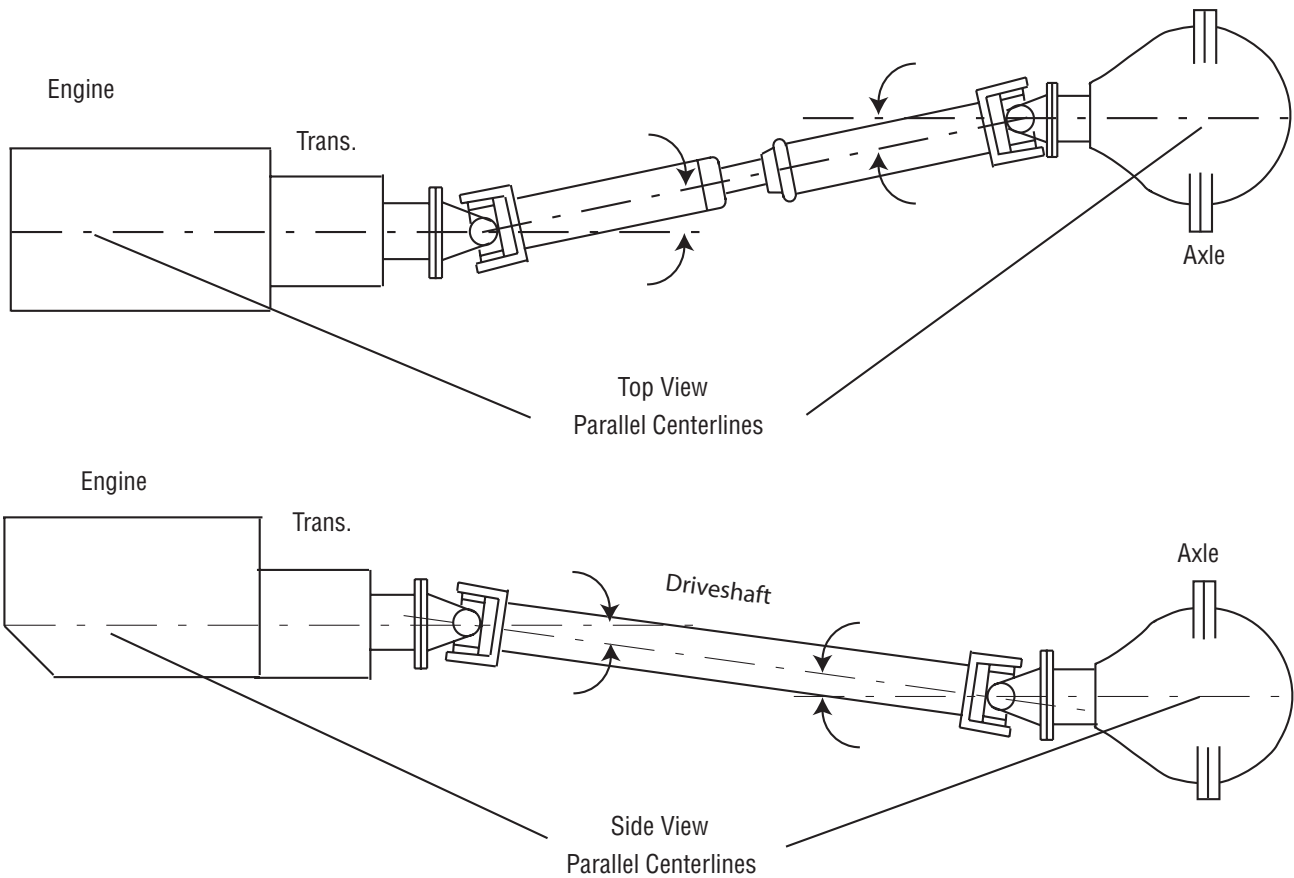

**Figure 5**

When you have a compound angle, you have to calculate the "True Universal Joint Operating Angle" of each universal joint. It is the True Universal Joint Operating Angle that must meet the three rules shown on page 5.



## True Universal Joint Operating Angle

The True Universal Joint Operating Angle, which must be calculated for each end of the shaft with compound angles, is a combination of the universal joint operating angle in the top view, as determined from the chart, and the measured universal joint operating angle in the side view.

To determine the true universal joint operating angle for one end of a shaft, (compound angle  $C^\circ$  in the formula shown in Fig. 6) insert the universal joint operating angle measurement obtained in the side view and the universal joint operating angle obtained from the chart into the formula.

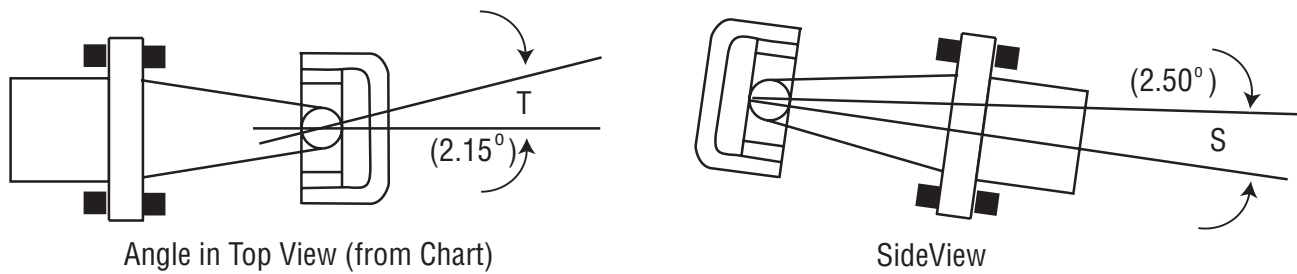

$$\text{Compound Angle } (C^\circ) = \sqrt{T^2 + S^2}$$

$$T = 2.15^\circ \text{ (A calculated angle)}$$

$$S = 2.5^\circ \text{ (The measured angle)}$$

$$C = \sqrt{2.15^2 + 2.5^2}$$

$$C = \sqrt{10.873}$$

$$C = 3.3^\circ \text{ (True operating angle)}$$

**Figure 6**

Do the same for the other end of the shaft. Compare the resultant calculated universal joint operating angle for each end. They should be EQUAL within 1 degree. If they're not, the driveshaft will vibrate.

## Eliminating Compound Angle Induced Vibrations

Compound universal joint operating angles are one of the most common causes of driveline vibration. To avoid these problems, remember these important points:

- When setting up an application that requires compound universal joint operating angles, always keep the centerlines of the transmission and axle parallel in both views.
- Always keep the offset between their horizontal and vertical centerlines small.

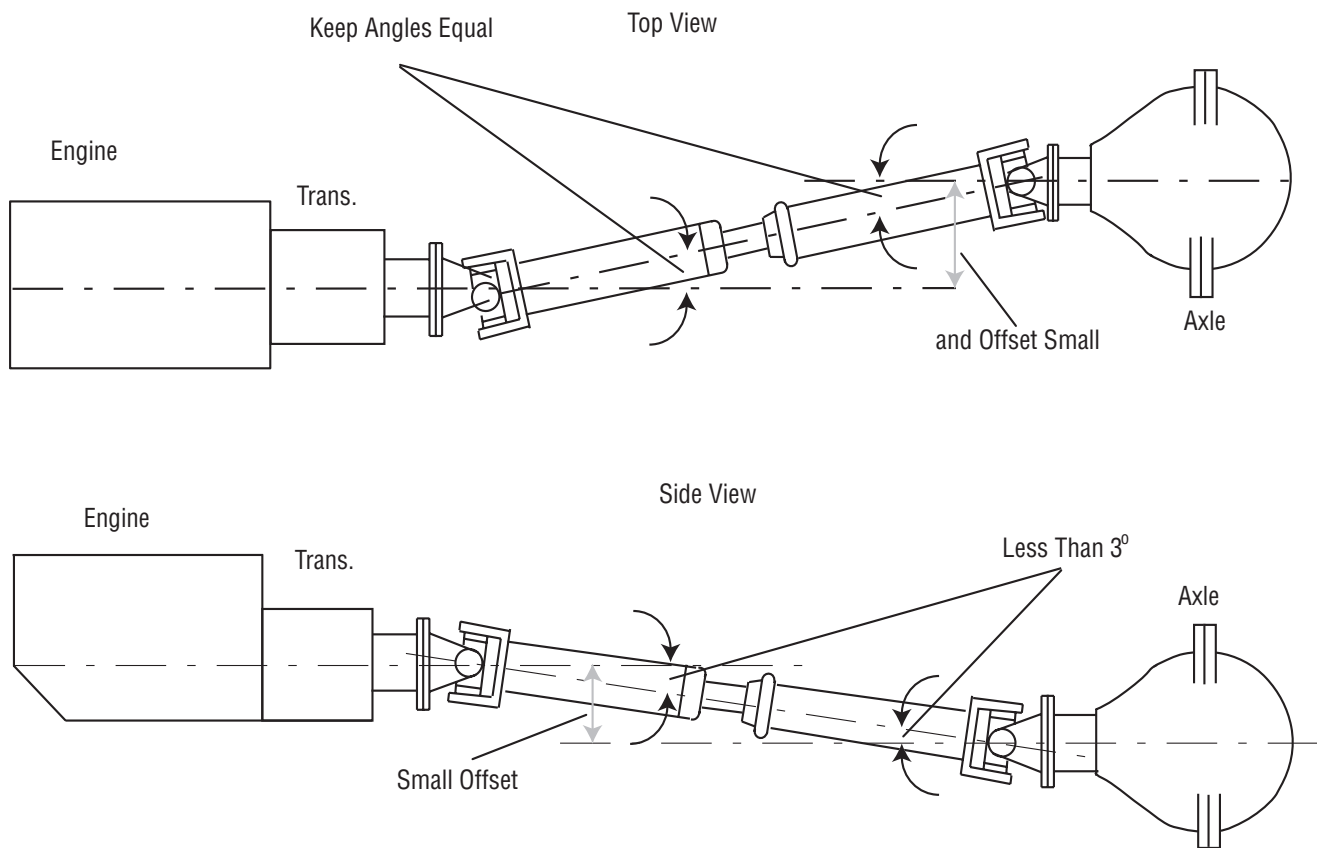

**Figure 7**

**Note:** Centerlines of transmission and axle must be parallel in both top and side views to use this method of determining true universal joint operating angle. Please contact Spicer Driveshaft Engineering if you have an application where the components cannot be installed with their centerlines parallel.

If adjustments must be made to the system:

- Install shims between the axle housing and springs to rotate the axle input yoke to change operating angles.
- Change operating angle on torque arm type suspensions by lengthening or shortening torque arms.
- Raise, lower, or shift side-to-side a pump, blower, or other piece of auxiliary equipment to change operating angles.

**Note:** It is important to remember to keep the centerlines of two components that are connected by a driveshaft parallel in both the top and side views, so the operating angles will ALWAYS be equal.

## Angle Size

The magnitude of a vibration created by a universal joint operating angle is proportional to the size of the universal joint operating angle. Spicer Engineers recommend true universal joint operating angles of 3 degrees or less.

Obtain the true universal joint operating angle, as explained above, and if it is greater than 3 degrees, compare it to this chart.

Driveshaft RPM	Maximum Operating Angle	Interaxle	
		Parallel	Intersecting
5000	3.2°	-	-
4500	3.7°	-	-
4000	4.2°	3.8°	3.8°
3500	5.0°	4.4°	4.4°
3000	5.8°	5.1°	4.8°
2500	7.0°	6.0°	4.8°
2000	8.7°	6.0°	4.8°
1500	11.5°	6.0°	4.8°

The angles shown on this chart are the maximum universal joint operating angles recommended by Spicer Engineers and are directly related to the speed of the driveshaft. Any universal joint operating angle greater than 3 degrees will lower universal joint life and may cause a vibration. Remember to check maximum safe driveshaft RPM by using the Spicer Safe Operating Speed Calculator.

## Multiple Shaft Installations

### Multiple Shaft Set Up Recommendations

In general, multiple shaft installations follow the same guidelines, except there are different recommendations for setting up the driveline:

- For a 2-shaft application, set up the first coupling shaft (sometimes called a jackshaft) so that the universal joint operating angle that occurs at the transmission end is 1 to 1-1/2 degrees. (See Fig. 8)

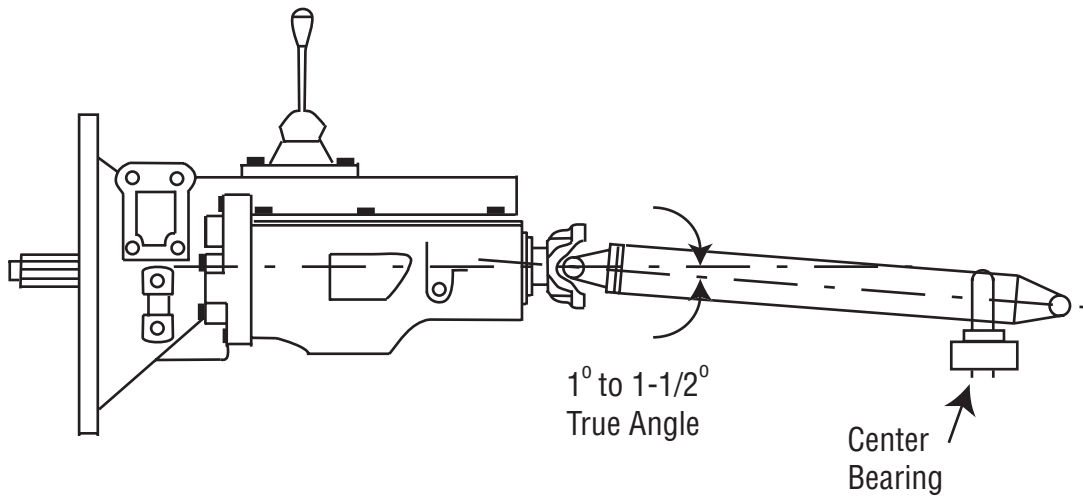
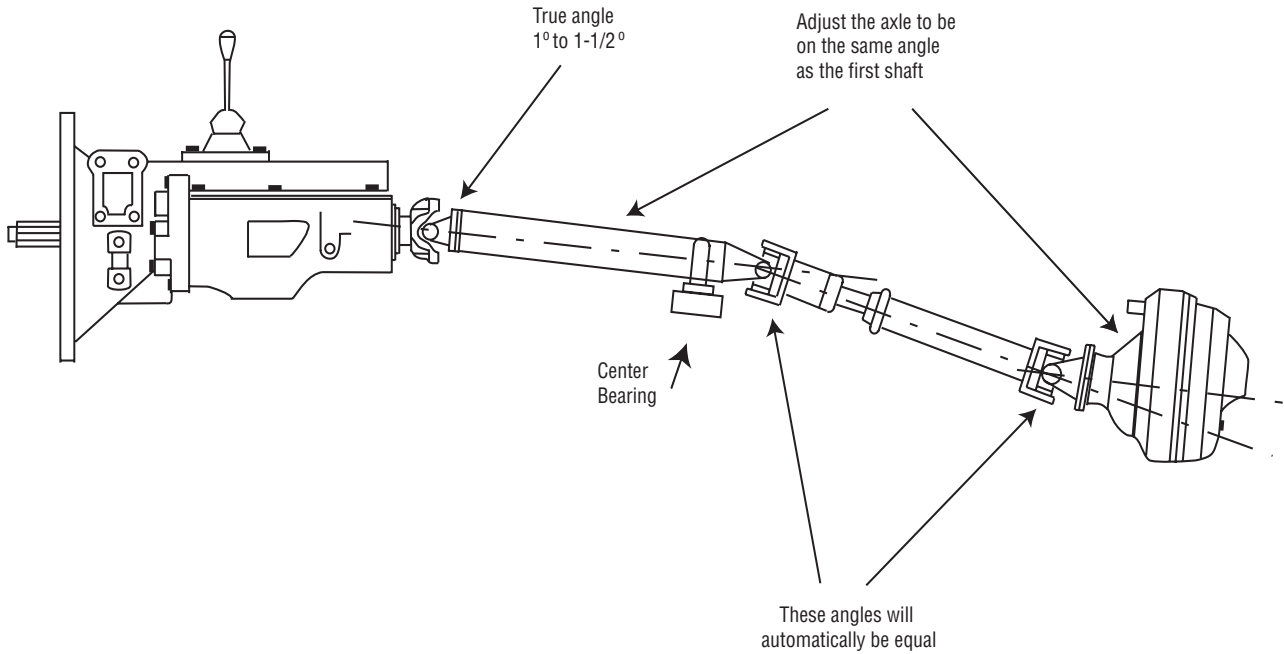

**Figure 8**

- Try to avoid building a compound universal joint operating angle into the first coupling shaft by installing it in line with the transmission.
- If it ends up being compound, make sure the true universal joint operating angle, determined by using the information mentioned earlier, is 1 to 1-1/2 degrees.

Install or tilt the axle so it is mounted on the same angle as the first coupling shaft (the centerlines of the axle and the first coupling shaft will be parallel).

**Note:** BY FOLLOWING THIS PROCEDURE, THE UNIVERSAL JOINT OPERATING ANGLE AT EACH END OF THE LAST SHAFT WILL AUTOMATICALLY BE EQUAL. (See Fig. 9)



**Figure 9**

If there is an offset in the installation of the axle, make sure it does not create too large of a compound universal joint operating angle. Whenever possible, mount the axle directly in line with the first coupling shaft (when viewed from the top).

Check the actual universal joint operating angle at the rear of the first coupling shaft. If it is less than 1° and the transmission universal joint operating angle is greater than 1.5°, rotate the end yoke at the center bearing position so that the ears of the yoke are 90° to the ears of the tube yoke on the transmission end of the coupling shaft. (See Fig. 10) As an alternative, rotate the slip yoke on the driveshaft 90° if the slip spline has 16 teeth.

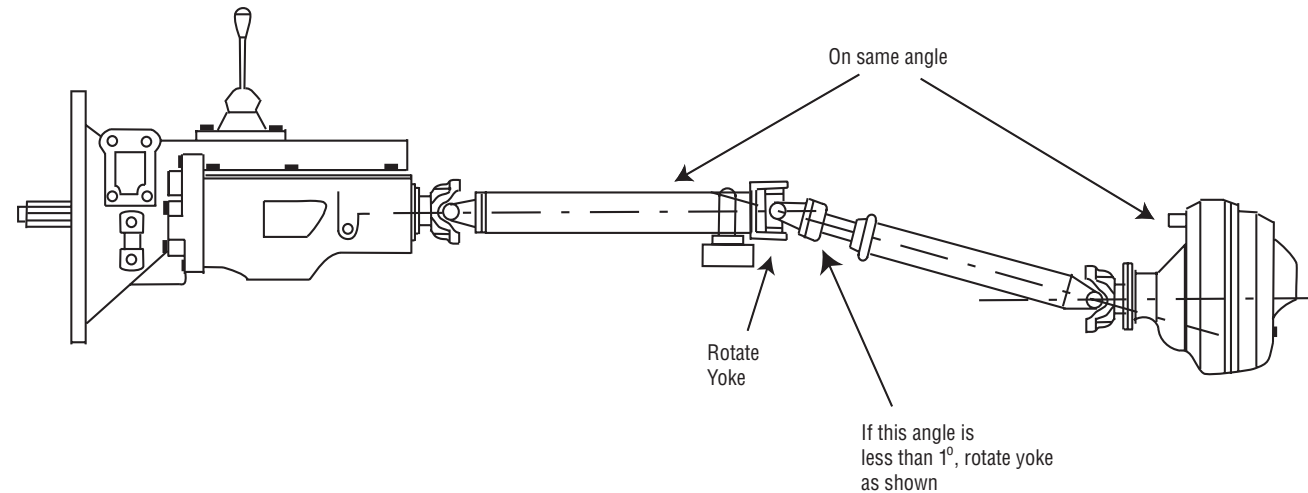
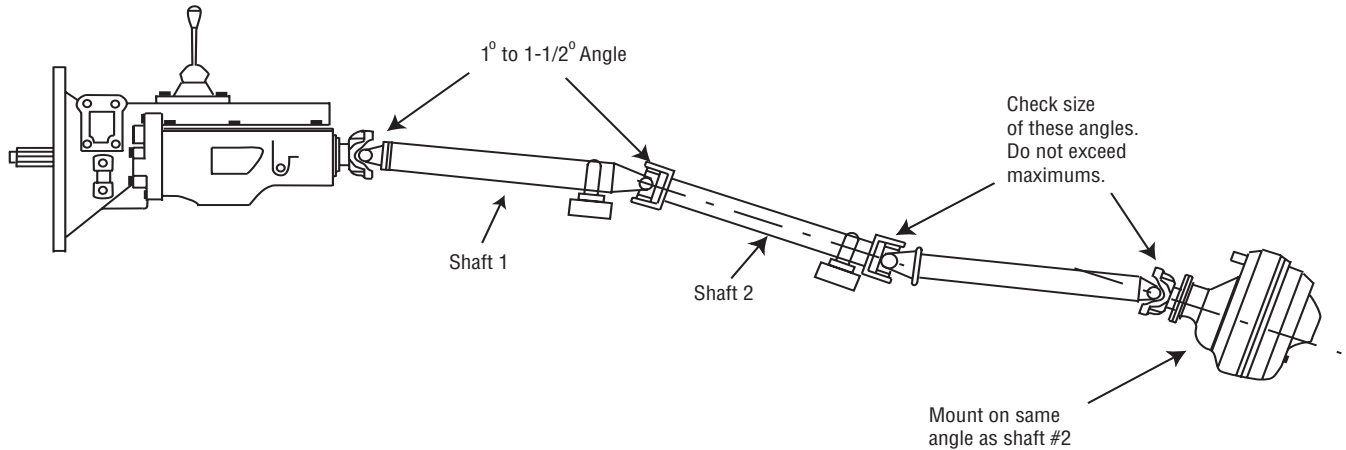

**Figure 10**

On applications having more than two shafts, mount the first coupling shaft as outlined in the preceding example, and each additional coupling shaft at a 1 to 1-1/2 degree universal joint operating angle to the previous coupling shaft.

Install or tilt the axle to the same angle as the last fixed coupling shaft so the centerline of the axle and the last fixed coupling shaft are parallel.

**Note:** THIS ASSURES THE UNIVERSAL JOINT OPEARATING ANGLE AT EACH END OF THE LAST SHAFT WILL AUTOMATICALLY BE EQUAL (See Fig. 11).



**Figure 11**

## Mounting a Midship-Mounted PTO, Pump, or Auxiliary Transmission

When installing a midship-mounted PTO, auxiliary transmission, or midship-mounted pump into the main driveline of a vehicle, install it at the same angle as the transmission. Keep the offset to a minimum to reduce universal joint operating angles.

**Note:** Do not make the universal joint operating angle less than 1/2 degree.

Before bolting the device in place, check the universal joint operating angles that occur at each end of the driveshaft. They must be 1 to 1-1/2 degrees and they must be equal to within 1/2 degree for this type of application.

If the device ends up being installed in direct line with the transmission, with little or no universal joint operating angle on the joints, raise or lower it so there is enough offset to create the required 1 to 1-1/2 degree universal joint operating angle on each end of the driveshaft. (See Fig. 12)

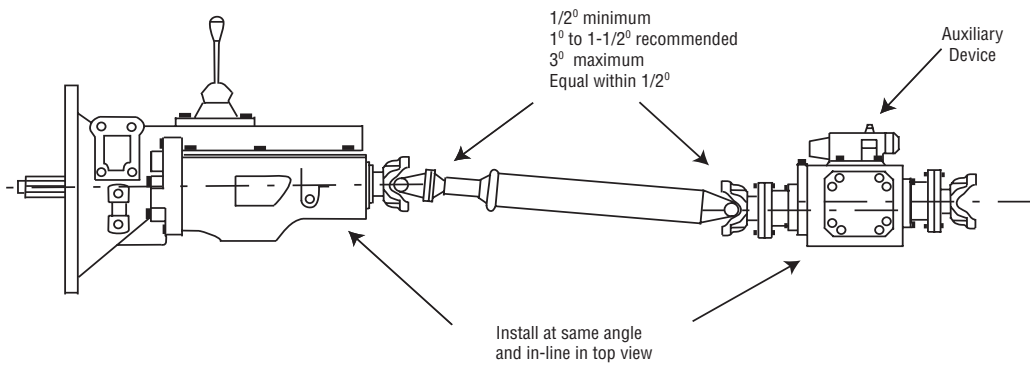

Figure 12

If there is only one driveshaft between the device and the rear axle, rotate the rear axle (using shims in the appropriate place) so it is the same angle as the device. This makes the universal joint operating angle at each end of the driveshaft equal (See Fig. 13). Check the size of the universal joint operating angles to determine if they meet recommendations.

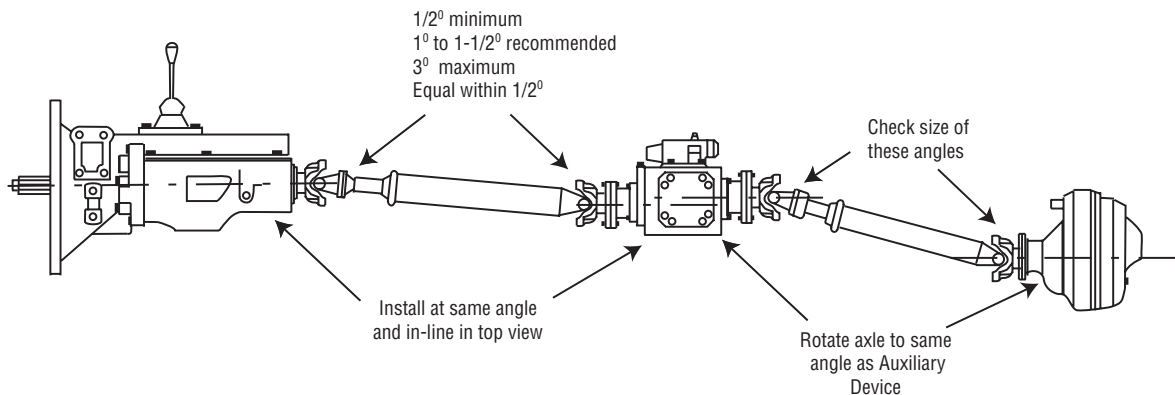
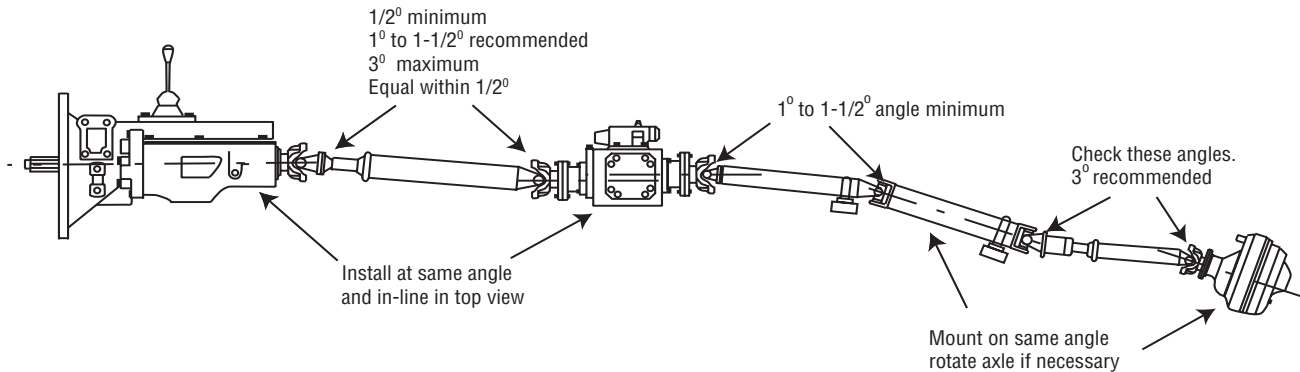

Figure 13

If there is more than one driveshaft between the device and the rear axle, install the driveshaft as outlined earlier with a 1 to 1-1/2 degree universal joint operating angle on the input end of each shaft. Then rotate the axle so it is on the same angle as the last fixed shaft. The universal joint operating angle on each end of the last shaft will automatically be equal. (See Fig. 14)



**Figure 14**

## Mounting a Remote-Driven Pump, Blower, or Similar Device

Remote mounted-pumps, blowers, or similar devices are usually driven by a side, top, or bottom-mounted PTO and use an auxiliary driveshaft.

Many times these devices are mounted to the vehicle frame or cross member. The usual method of mounting, where the driven device is mounted parallel with the ground without regard to the mounted angle of the PTO, will produce a vibration that may cause failure of the PTO, pump, blower, or other driven device.

Any remote driven device must be mounted parallel and in line, if possible, with the PTO.

To select the appropriate auxiliary driveshaft for these types of applications, you should consider proper torque, safe operating speed (which is different than the critical speed for tubular driveshafts), and angularity. (See Maximum Safe Operating Speed Chart on page 18).

An auxiliary driveshaft must be capable of transmitting the maximum torque and RPM required by the driven equipment. For most low-torque applications operating at less than 1200 RPM, solid bar-stock constructed driveshafts are adequate. For applications requiring additional torque or RPMs, tubular shafts should be fabricated.



## Maximum Safe Operating Speed

MAXIMUM OPERATING SPEED* BY TUBE SIZE, SOLID SHAFT SIZE, AND LENGTH											
*(For speeds over 6000 RPM, contact Spicer Universal Joint Division Engineering)											
TUBING	MAXIMUM INSTALLED LENGTH (IN INCHES) FOR GIVEN RPM										
Diameter & Wall Thickness W - Welded S - Seamless	Centerline to Centerline of Joints for a Two Joint Assembly or Centerline of Joint to Centerline of Center Bearing for a Joint and Shaft										
	RPM - Revolutions Per Minute										
	1000	1500	2000	2500	3000	3500	4000	4500	5000	5500	6000
1.750" x .065" W	82"	67"	58"	52"	-	-	-	-	-	-	-
1.250" x .095" S	64"	52"	45"	40"	37"	34"	32"	-	-	-	-
2.500" x .083" W	87"	70"	62"	55"	50"	45"	43"	41"	39"	37"	35"
3.000" x .083" W	-	-	85"	76"	70"	64"	60"	57"	54"	51"	49"
SOLID SHAFT DIAMETER											
.750"	42"	35"	30"	27"	25"	-	-	-	-	-	-
.812"	44"	36"	31"	28"	26"	-	-	-	-	-	-
.875"	46"	37"	32"	29"	27"	-	-	-	-	-	-
1.000"	49"	40"	35"	31"	28"	-	-	-	-	-	-
1.250"	55"	45"	39"	35"	32"	-	-	-	-	-	-

Maximum Operating Speed

To prevent premature wear, auxiliary driveshaft breakage, and possible injury to people or equipment, be aware of the critical speed of these types of driveshafts. Critical speed, explained earlier in this guide, is different for these solid shaft and small tube driveshafts.

Refer to the chart above for maximum safe operating speed information on these types of shafts.

If the chart indicates that the critical speed may be a problem, use multiple shafts. Be sure to use support bearings where necessary and set up the true universal joint operating angles as indicated earlier in this guide.

As with all driveshafts, auxiliary driveshafts should be:

- Carefully installed to minimize vibrations caused by incorrect universal joint operating angles
- Capable of absorbing shock loads
- Capable of changing length as needed
- Guarded so as to prevent inadvertent entanglement

---

### Special Notes Regarding Auxiliary Driveshafts



**WARNING:** Working on or near an auxiliary driveshaft when the engine is running is extremely dangerous and should be avoided. You can snag clothes, skin, hair, hands, etc. This can cause serious injury or death.

- Shut off engine before working on power take-off or driven equipment.
- Do not go under the vehicle when the engine is running.
- Do not engage or disengage driven equipment by hand from under the vehicle when the engine is running.
- Fasteners should be properly selected and torqued to the manufacturer's specifications.
- If a setscrew protrudes above the hub of an end yoke, you may want to replace it with a recessed (Allen-type) setscrew.
- If you decide that a recessed setscrew does not have enough holding power for your application and you must use a protruding setscrew, be sure no one can come in contact with the rotating driveshaft or the protruding setscrew.
- **Exposed rotating driveshafts must be guarded!**
- Lubricate auxiliary driveshafts according to manufacturer's specifications.





**SPICER<sup>®</sup>**

*Drivetrain Products*

**Dana Holding Corporation  
Spicer Service Parts**  
PO Box 321  
Toledo, Ohio 43697-0321  
1-800-SAY-DANA (729-3262)

[www.spicerparts.com](http://www.spicerparts.com)

**Dana Holding Corporation  
Spicer Service Parts - Canada**  
5095 South Service Road  
Beamsville, Ontario LOR 1B0

**Dana Holding Corporation  
Spicer Service Parts - International**  
(419) 861-6325

**J3311-1-DSSP**  
8/08  
Printed in U.S.A

© Dana Limited 2008.  
All rights reserved.

# **Section 4**

## **Pump Detail**

# W.S. DARLEY & CO.

## Operating/Troubleshooting Instructions for Darley Electrically-Clutched Belt-Driven Priming Pump

The Darley electrically-clutched belt-driven primer will develop up to 25 in. Hg. in an air tight pumping system.

The Primer is activated by a push-button momentary electric switch. Pushing and holding this switch in opens the 12/24 VDC electric  $\frac{1}{4}$  turn  $\frac{3}{4}$ " ball valve and closes the electrical circuit to energize the clutch, engaging the belt drive system, in turn spinning the primer rotor within the primer body. Releasing this switch will close the  $\frac{1}{4}$  turn electric valve and disengage the primer clutch, ending the priming cycle.

The 12/24 VDC electric  $\frac{1}{4}$  turn valve utilized in this system has a 0.8 second cycle time as well as a logic controller to make necessary adjustments internally depending on input voltage, therefore maintaining a constant 0.8 seconds open/close cycle time. This valve will act as a bubble tight check valve, therefore once the momentary push to prime switch is released, this  $\frac{1}{4}$  turn valve will automatically close and contain the prime of the pump system.

Before the pump can be primed, booster line valves, drain valves, cooling line valve, and all other openings into the pump must be closed and absolutely air tight. In cases where the discharge side of the pump is sealed by a check valve, the main discharge valves need not be closed.

When operating from draft, suction hose connections must be tight and free of air leaks.

Make certain the suction hose strainer is properly submerged and free of foreign material.

The main pump drive must be engaged to initiate priming

### CAUTION

#### FOR ALL PRIMING SCENARIOS:

If water does not discharge from the primer exhaust within 80 seconds stop the primer pump, check for air leaks and resolve the issue before attempting to re-prime. **MAX PRIMER OPERATION TIME = 80 seconds. DO NOT EXCEED 80 SECONDS OF PRIMER OPERATION.** Repeated operation should be avoided.

### CAUTION

The primer pump generates heat as soon as operation begins. Extended run times (up to 80 seconds) and repeating priming cycles consecutively or within short time periods may lead to accelerated wear or premature failure of the primer pump assembly. If an attempt to prime should fail, thoroughly inspect the pump system for air leaks and resolve the issue before attempting re-prime.

## **Priming Procedure:**

To prime the pump a certain amount of dry running of the pump along with a recommended engine speed are given. Significant testing has proven these figures at W.S. Darley and should never be exceeded without W.S Darley Customer Service approval.

Priming time should not exceed 80 seconds. If pump fails to prime within 80 seconds, shut down and thoroughly inspect the pump system for air leaks and resolve the issue before attempting to re-prime.

Engine speed during priming should NOT exceed 1000 RPM regardless of the pump and/or PTO ratio in relation to engine speed.

To Prime: Engage the pump per the shifting procedure outlined in Section 2, and ramp engine speed to no more than 1000 RPM. Press the "Push-to-Prime" momentary switch and hold. Prime should occur within 80 seconds. Indication of Prime should be noticed when water discharges from the primer pump exhaust port. Releasing the momentary switch will disengage the primer clutch and close the primer ¼ turn ball valve. Prime should now be attained and contained.

Under normal conditions, the primer will evacuate the pump and 20' of 8" hose within 24 seconds.

As soon as prime is reached the pump will develop pressure.

When pumping from hydrants, the primer is not needed and must be kept closed.

It may be necessary to use the primer momentarily when pumping from a booster tank when the suction head is insufficient to force all the air out of the pump.

## **Lubricating System – Electric Priming Pump with Fluid Reservoir**

The electrically-clutched belt-driven rotary-vane primer pump creates a high vacuum by continuous lubrication of rotor and vanes. Therefore the primer lubricant supply tanks (4 quarts) should be kept full at all times.

Recommended primer system lubricant is Darley PRIME GREEN. PRIME GREEN is an environmentally safe, non-toxic, biodegradable lubricant. Its use assures proper primer vane lubricant while minimizing environmental effects.

After the main pump is drained, run the primer motor to drain primer lines and re-lubricate the primer pump.

The vent-hole on the lubricant tank cap should be kept open at all times to prevent siphoning of lubricant from the tank after the pump is stopped. Do not increase the size of this hole.

Locate the lubricant tank where it may be conveniently inspected and filled.

Should water appear in the lubricant supply tank, the primer valve is leaking. Check and replace valve plug seal o-rings as necessary.

## **Troubleshooting:**

-If the electric clutch is not functioning / slipping beyond normal operating characteristic:

- Check system supplied voltage. Under a static energized condition the clutch should be pulling 12 VDC @ 4.89 Amps with 2.45 Ohms (+/- 5%) of resistance across the coil and 24 VDC @ 1.26 Amps with 9.51 Ohms (+/- 5%) of resistance across the coil; depending on the clutch (12 or 24 VDC) being used. Note that these figures are at an ambient temperature of 68°F.
- These figures can be checked with the correct measuring/inspection equipment. Such as a properly calibrated Multi Meter with a Current Clamp.
- Any deviation from these figures when experiencing clutch challenges could indicate a problem with the clutch coil or an insufficient supply voltage and current. Contact W.S. Darley Customer Service if these problems occur.

-Vibration in belt/clutch assembly:

- Could be indicated by:
  - Damaged Belt
  - Contaminated Bearing
  - Loose clutch body mounting bolt (through clutch bore into primer rotor/shaft assembly)
  - Loose bolts holding belt tension
    - Revisit the primer assembly drawing and contact W.S. Darley Customer Service if necessary. Proper belt tension is a must.
    - Belt tension can be inspected and validated by:
      - Placing a 6 lb– 7 lb force on the belt along its periphery directly between the center axis of each pulley. The belt should deflect approximately 5/32" +/- .015"; beyond these figures in either direction +/- will yield a belt tension that is too loose or too tight and will detrimentally affect belt, sheave and clutch life.
  - Damaged rotor/shaft assembly
  - Damaged or broken primer vane
  - Particulate trapped in primer/rotor body vane area
  - Excessive slipping in between clutch armature assembly and friction material
    - If this occurs, excessive heat may generate, causing warpage and damage to the armature and friction material
    - Heat signs will show, bluing and blackening of surrounding areas from heat source



- Trapped particulate entrained in air gap (between armature assembly and friction material)
- Damage or Failure of 1, 2 or all 3 of the clutches spring plates.
  - These plates hold the pulley sheave to the armature assembly, transferring rotational energy of the pulley sheave through the belt drive to the clutch friction material (when the clutch coil is energized) and correspondingly through the primer rotor/shaft assembly creating a vacuum in the rotary vane primer pump. These spring plates allow for this transfer as well as allow the energized clutch coil to overcome the spring force in these plates and close the air gap between the armature assembly and the friction material, or vice versa re-establishing the air gap and preventing the belt drive system from transferring rotational energy to the rotary vane primer pump.

-Excessive belt wear

- Could be indicated by:

- Misalignment between Driver and Driven pulleys

- Axial or Angular

- Revisit the primer assembly drawing and contact W.S. Darley Customer Service if necessary. Belt drives must have nearly zero misalignment for long life and proper function.

-Minimal vacuum creation by Primer

- Damaged vanes

- Loss of original lubrication in primer rotor housing and vanes

- Particulate trapped in vane housing

- Causing vane(s) not to fully engage and disengage in vane housing/rotor

- Would prevent vacuum creation or severely inhibit such

- Other challenges may occur that have not been listed here, we kindly ask that you document these challenges as best you can and contact W.S. Darley Customer Service to identify the root cause and evaluate any necessary changes in the design.

*For challenges and assembly/disassembly assistance:*

**CONTACT DARLEY CUSTOMER SERVICE IMMEDIATELY AT 1-800-634-7812 or 715-726-2650**

NO.	DESCRIPTION	PART NO.	QTY.
1	ASSY - ROTOR, 25 CU IN VAC PUMP	4434310	1
2	BEARING - OILITE, 1.000 ID	1760006	1
3	BEARING - OILITE, 1.250 ID	1760033	1
4	BELT - PRIMER DRIVE	4226900	2
5	BRACKET - SUPPORT, PRIMER	4038000	1
6	CLUTCH - VAC PUMP, 12VDC	4227001	1
8	CYLINDER - VACUUM PUMP, 25 CU IN	1021100	1
9	HEAD - CYL, VAC PUMP, 25 CU IN	2812900	1
10	HHCS - .25-20 X .83, GR 5 SST	5400603	2
11	HHCS - .313-18 X 0.75, SST	5400641	1
12	HHCS - .438-20 X 2.75, GR5	5400118	1
13	HHCS - FLANGED, .313-18 X .750	5402833	9
15	HHCS - FLANGED, .375-16 X .88	5402835	1
16	HHCS - FLANGED, .375-16 X 1.00	5402845	2
17	HHCS - FLANGED, .375-16 X 1.25	5402856	1
18	NUT - HEX, .313-18, NYLOC, SST	5403400	1
19	SEAL - FURON MECHANICAL, 1.250	1843403	1
20	SHCS - .250-20 X 0.37 SST	5401400	1
21	SPACER - 406 X .88 X .38	3309000	1
22	STRAP - CLUTCH ANTI-ROTATION	4038110	1
23	VANE - ROTOR, 25 CU IN, .1905 THICK	4434200	4
24	WASHER - 1.00 X 1.50 X .273 SS	3603342	1
25	WASHER - FLAT, .375 ID	3603820	1
26	WASHER - FLAT, 0.31 ID, SST	3603812	1
27	WASHER - LOCK, 0.250 ID, SST	3603532	2
28	FLANGE - COMP., 1810/1710/1610	4822400	1
30	RETAINER - BEARING, PRIMER CLUTCH	2314400	1
31	O-RING - 4.75 X 4.94 X 0.09	3601114	1
32	BUSHING - PIPE, 1 X 0.75 BR	1080648	1
33	ELBOW - .75 M X .75 F	3500543	1
34	FITTING-.75NPTMx.75J/CM	3501553	2
35	FTG - BARB, 1.00 ID X 1.00 NPT MALE	3502031	1
36	NIPPLE - PIPE, .75 X CLOSE, BR	1081048	1
37	PLATE - PRIMER, PUSH BUTTON	1978500	1
38	PLATE - PRIMER LUBRICANT TANK	1963400	1
39	PULLEY - PRIMER DRIVE	4822600	1
40	SWITCH - C7H, PUSH-BTN	2600008	1
41	TANK - PRIMER, 4 QUART, W/CAP	4403703	1
42	TUBE - PRIMER CONNECT	4434800_ZSM	1
43	TUBE - ROUND, 0.19 X 6", NEO	1101937	1
44	TUBE FITTING - STR, .25 X .19	3500021	1
45	VALVE - ACTUATED, 12/24VDC, .75NPT FE	5209404	1

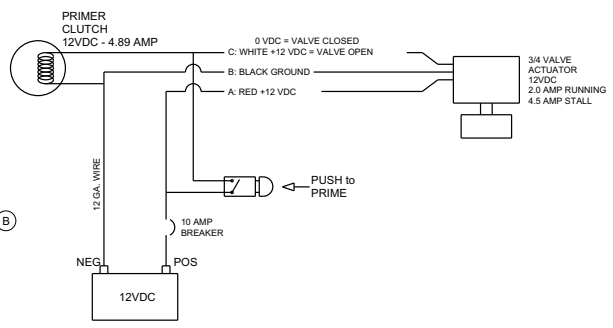

REVISIONS				
LTR	DESCRIPTION	DATE	CHG NO.	APPROV
A	ADDED PLUMBING AND DRIVE COMPONENTS	18DEC2012	8/16	WAH
B	5400118 WAS 5400109	02AUG2013	10265	SMS

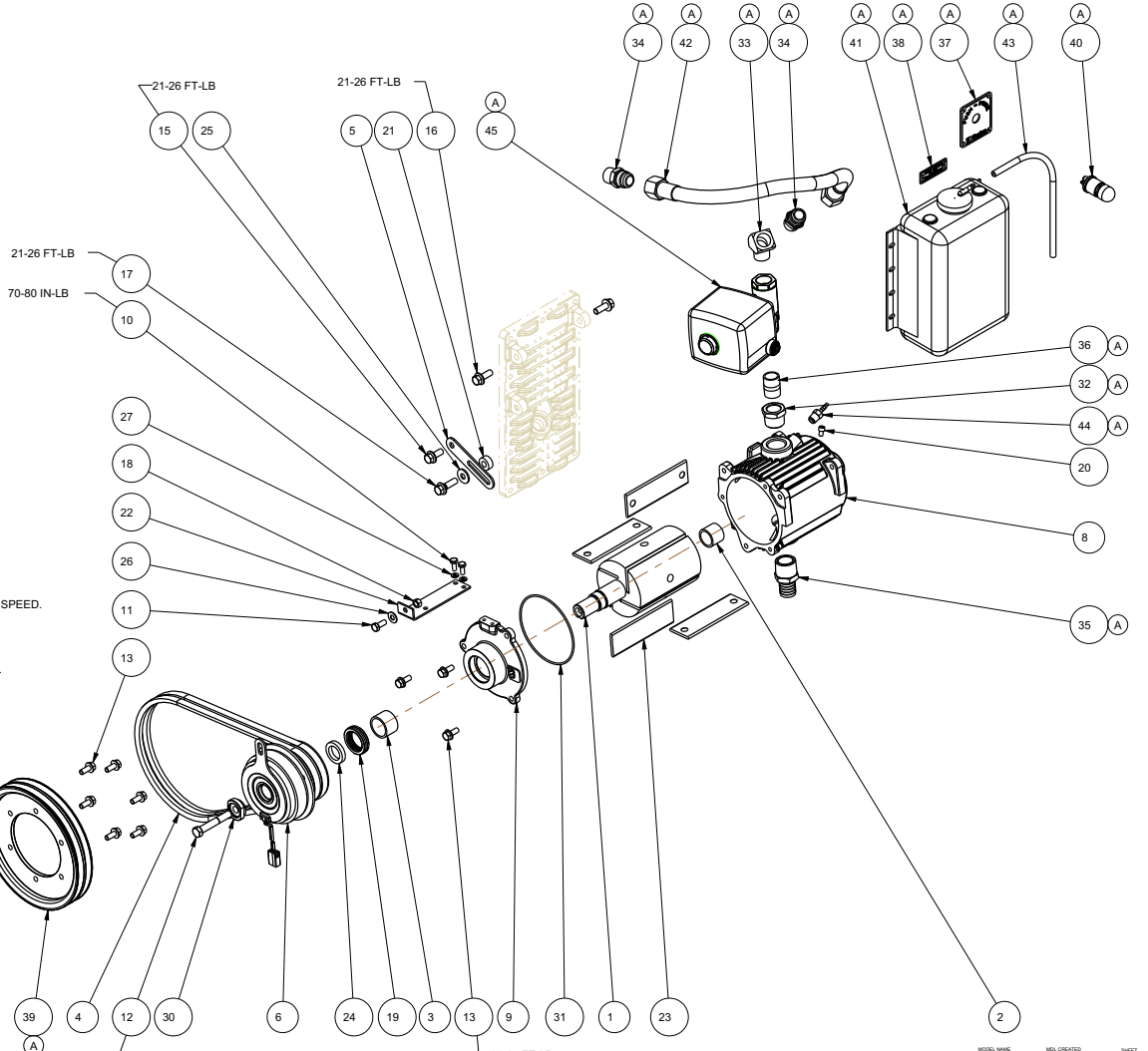

- NOTES:**
- 1) TIGHTEN A NEW BELT UNTIL THERE IS 30 TO 60 LBF STATIC TENSION PER BELT. THIS CORRESPONDS TO A 2.2 TO 4.1 LBF DEFLECTION FORCE RESULTING IN A .16 INCH DEFLECTION AT THE BELT MIDSPAN.
- REFERENCE NOTES:**
- 1) THE BELTS ARE CAPABLE OF TRANSMITTING 11.28 HP AT 1000 RPM DRIVELINE SPEED.
  - 2) THERE IS A 2.1998:1 SPEED INCREASE BETWEEN THE DRIVELINE AND THE PRIMER.
  - 3) IF A GATES 5070 SONIC TENSION METER IS USED, SET WEIGHT TO 114.2, WIDTH TO 1 AND SPAN TO 287.0. THE DESIRED FREQUENCY IS 64 TO 90 HZ WHEN THE BELT IS NEW AND 59 TO 84 HZ WHEN THE BELT IS USED.
  - 4) A 1550 SERIES JOINT REQUIRES A 4-2-689 FLANGE YOKE.
  - 5) A 1610 SERIES JOINT REQUIRES A 5-2-379 FLANGE YOKE.
  - 6) A 1710 SERIES JOINT REQUIRES A 4819900 (6-2-739-1) FLANGE YOKE.
  - 7) A 1760 SERIES JOINT REQUIRES A 4820000 (6-3-2-19-1) FLANGE YOKE.
  - 8) A 1810 SERIES JOINT REQUIRES A 4820100 (6.5-2-329-1) FLANGE YOKE.

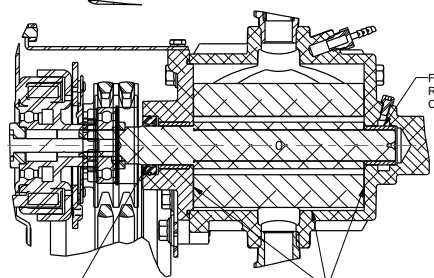

FILL LIP SEAL WITH MULTI-PURPOSE BEARING GREASE PRIOR TO ASSEMBLY

SECTION A-A  
SCALE 1/2

APPLY THIN COAT DOW CORNING 111 SILICONE LUBRICANT TO THE END CAP, HOUSING BORE AND HOUSING END CAP SURFACES TO ENHANCE THE VANE SEAL

243 LOCTITE THREAD LOCKER  
TIGHTEN TO 50-55 FT-LB

REMOVE SHARP EDGES		INCH [MILLIMETER]		OLD PART NO. AP02110		TOLERANCE EXCEPT AS NOTED		DATE 21-May-10		SCALE 1:1	
MATERIAL DESCRIPTION		MATERIAL NO.		PATTERN NO.		TOLERANCE EXCEPT AS NOTED		DATE 21-May-10		SCALE 1:1	
THIS DESIGN IS THE PROPERTY OF W.S. DANIEL & CO. UNAUTHORIZED REPRODUCTION IS PROHIBITED.		ALL DIMENSIONS IN INCHES UNLESS NOTED		DO NOT SCALE PRINT		W.S. DANIEL & CO. PRIMER - BELT DRIVEN, 12VDC WARNER CLUTCH		DVC0300			

NO.	DESCRIPTION	PART NO.	QTY.
1	ASSY - ROTOR, 25 CU IN VAC PUMP	4434310	1
2	BEARING - OILITE, 1.000 ID	1760006	1
3	BEARING - OILITE, 1.250 ID	1760033	1
4	BELT - PRIMER DRIVE	4226900	2
5	BRACKET - SUPPORT, PRIMER	4038000	1
6	CLUTCH - VAC PUMP, 24VDC	4227011	1
8	CYLINDER - VACUUM PUMP, 25 CU IN	1021100	1
9	HEAD - CYL, VAC PUMP, 25 CU IN	2812900	1
10	HHCS - .25-20 X .63, GR 5 SST	5400603	2
11	HHCS - .313-18 X 0.75, SST	5400641	1
12	HHCS - .438-20 X 2.75, GR5	5400118	1
13	HHCS - FLANGED, .313-18 X .750	5402833	9
15	HHCS - FLANGED, .375-16 X .88	5402835	1
16	HHCS - FLANGED, .375-16 X 1.00	5402845	2
17	HHCS - FLANGED, .375-16 X 1.25	5402856	1
18	NUT - HEX, .313-18, NYLOC, SST	5403400	1
19	SEAL - FURON MECHANICAL, 1.250	1843403	1
20	SHCS - .250-20 X 0.37 SST	5401400	1
21	SPACER - .406 X .88 X .38	3309000	1
22	STRAP - CLUTCH ANTI-ROTATION	4038110	1
23	VANE - ROTOR, 25 CU IN, .1905 THICK	4434200	4
24	WASHER - 1.00 X 1.50 X .273 SS	3603342	1
25	WASHER - FLAT, .375 ID	3603820	1
26	WASHER - FLAT, 0.31 ID, SST	3603812	1
27	WASHER - LOCK, 0.250 ID, SST	3603532	2
28	FLANGE - COMP., 1810/1710/1610	4822400	1
30	RETAINER - BEARING, PRIMER CLUTCH	2314400	1
31	O-RING - 4.75 x 4.94 x 0.09	3601114	1
32	BUSHING - PIPE, 1 x 0.75 BR	1080648	1
33	ELBOW - .75 M X .75 F	3500543	1
34	FITTING - 75NPTMx.75JICM	3501553	2
35	FTG - BARB, 1.00 ID X 1.00 NPT MALE	3502031	1
36	NIPPLE - PIPE, .75 X CLOSE, BR	1081048	1
37	PLATE - PRIMER, PUSH BUTTON	1978500	1
38	PLATE - PRIMER LUBRICANT TANK	1963400	1
39	PULLY - PRIMER DRIVE	4822600	1
40	SWITCH - C7H, PUSH-BTN	2600008	1
41	TANK - PRIMER, 4 QUART, W/CAP	4403703	1
42	TUBE - PRIMER CONNECT	4434800_ZSM	1
43	TUBE - ROUND, 0.19 X 6', NEO	1101937	1
44	TUBE FITTING - STR, .25 X .19	3500021	1
45	VALVE - ACTUATED, 12/24VDC, .75NPT FE	5209404	1

REVISIONS				
LTR	DESCRIPTION	DATE	CHG NO.	APPROV
A	ADDED PLUMBING AND DRIVE COMPONENTS	17DEC2012	8/18	WAH
B	5400118 WAS 5400109	02AUG2013	10/25	SMS

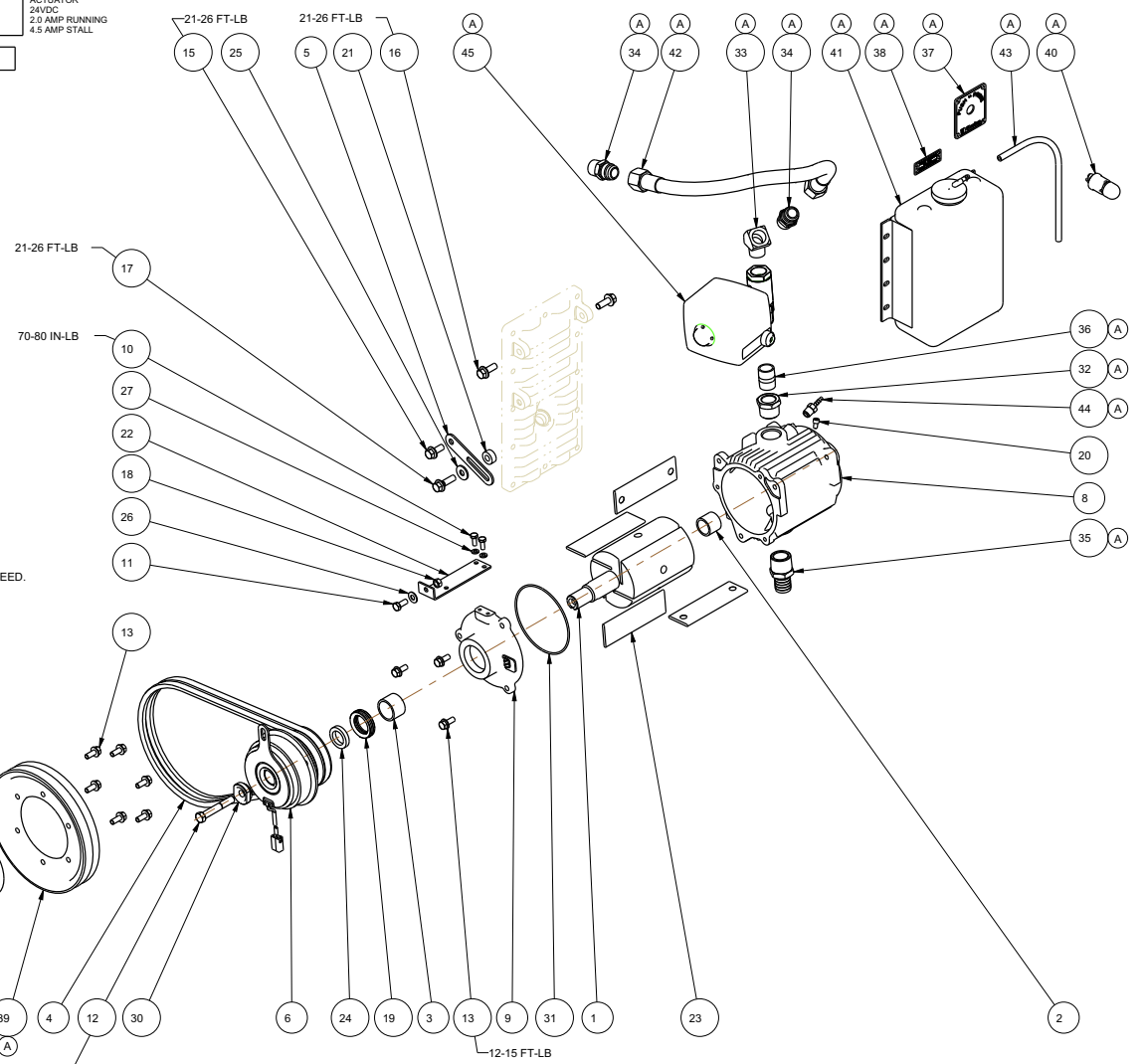
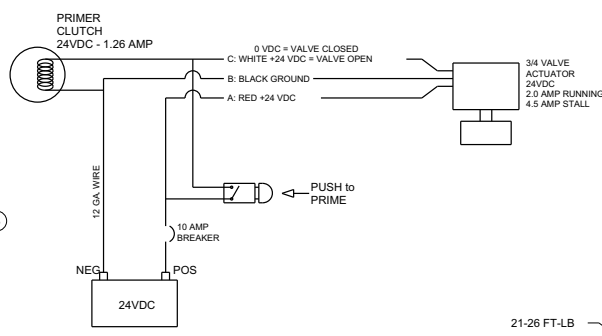

NOTES:  
 1) TIGHTEN A NEW BELT UNTIL THERE IS 30 TO 60 LBF STATIC TENSION PER BELT. THIS CORRESPONDS TO A 2.2 TO 4.1 LBF DEFLECTION FORCE RESULTING IN A .16 INCH DEFLECTION AT THE BELT MIDSPAN.  
 REFERENCE NOTES:  
 1) THE BELTS ARE CAPABLE OF TRANSMITTING 11.28 HP AT 1000 RPM DRIVELINE SPEED.  
 2) THERE IS A 2.1998:1 SPEED INCREASE BETWEEN THE DRIVELINE AND THE PRIMER.  
 3) IF A GATES 507C SONIC TENSION METER IS USED, SET WEIGHT TO 114.2, WIDTH TO 1 AND SPAN TO 267.0. THE DESIRED FREQUENCY IS 64 TO 90 HZ WHEN THE BELT IS NEW AND 59 TO 84 HZ WHEN THE BELT IS USED.  
 4) A 1550 SERIES JOINT REQUIRES A 4-2-689 FLANGE YOKE.  
 5) A 1610 SERIES JOINT REQUIRES A 5-2-379 FLANGE YOKE.  
 6) A 1710 SERIES JOINT REQUIRES A 4819900 (6-2-739-1) FLANGE YOKE.  
 7) A 1760 SERIES JOINT REQUIRES A 4820000 (6-3-2-19-1) FLANGE YOKE.  
 8) A 1810 SERIES JOINT REQUIRES A 4820100 (6.5-2-329-1) FLANGE YOKE.

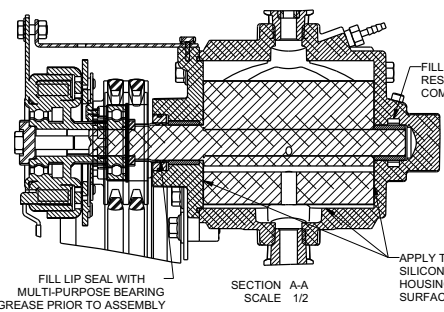

243 LOCTITE THREAD LOCKER  
 TIGHTEN TO 50-55 FT-LB

REMOVE SHARP EDGES		INCH [MILLIMETER]		OLD PART NO.	APR02120	REV. CREATED	22-FEB-2010	SHEET	1	TOTAL	1
MATERIAL DESCRIPTION		MATERIAL NO.		PATTERN NO.		TOLERANCE SPECIFICATIONS		 PRIMER - BELT DRIVEN, 24VDC WARNER CLUTCH			
THIS DESIGN IS THE PROPERTY OF W.S. DANEK AND IS UNAUTHORIZED REPRODUCTION IS PROHIBITED.		ALL DIMENSIONS IN INCHES UNLESS NOTED		DO NOT SCALE PRINT		DATE		21-May-10			
						SCALE		1:1			

DVC0301

NO.	DESCRIPTION	PART NO.	QTY.
1	ASSY - ROTOR, BELT DRV, R2	4434320	1
2	BEARING - OILITE, 1.000 ID, PORTED	1762900	1
3	BEARING-BALL, 6006 2RSR,T	1724800	1
4	BELT - PRIMER DRIVE	4226901	2
5	BRACKET - CLUTCH ANTI-ROTATION	4038010	1
6	CLUTCH - VAC PUMP, 12VDC	4227001	1
7	FTG - BARB, 1.00 ID X 1.00 NPT MALE	3502031	1
8	CYLINDER - VAC PUMP, 25 CU IN, R2	1021101	1
9	HEAD - CYL, VAC PUMP, 25 CU IN, R2	2812901	1
10	HHCS - .25-20 X .83, GR 5 SST	5400603	2
11	RING - RETAINER, HO-187 SS	3600462	1
12	HHCS - .438-20 X 2.75, GR5	5400118	1
13	HHCS - FLANGED, .313-18 X .750	5402833	9
14	NIPPLE - PIPE, .75 X CLOSE, BR	1081048	1
15	HHCS - FLANGED, .375-16 X .88	5402835	1
16	HHCS - FLANGED, .375-16 X 1.00	5402845	2
17	HHCS - FLANGED, .375-16 X 1.25	5402856	1
18	NUT - HEX, .313-18, NYLOC, SST	5403400	1
19	SEAL - FURON MECHANICAL, 1.250	1843403	1
20	SHCS - .250-20 X 0.37 SST	5401400	1
21	SPACER - .406 X .88 X .38	3390900	1
22	STRAP - CLUTCH ANTI-ROTATION	4038110	1
23	VANE - ROTOR, 25 CU IN, .1905 THICK	4434200	4
24	WASHER - 1.00 X 1.50 X .273 SS	3603342	1
25	WASHER - FLAT, .375 ID	3603820	1
26	RING - RETAINER, SH-118 SS	3600450	2
27	WASHER - LOCK, 0.250 ID, SST	3603532	2
28	PULLEY - PRIMER DRIVE	4822600	1
29	TUBE FITTING - STR, .25 X .19	3500021	1
30	RETAINER - BEARING, PRIMER CLUTCH	2314400	1
31	O-RING - 4.75 X 4.94 X 0.09	3601114	1
32	PLATE - PRIMER, PUSH BUTTON	1978500	1
33	SWITCH - C7H, PUSH-BTN	2600008	1
34	VALVE - ACTUATED, 12/24VDC, .75NPT FE	5209404	1
35	BUSHING - PIPE, 1 X 0.75 BR	1080648	1
36	FITTING-.75NPTMx.75JICM	3501553	1
37	SCREW - SHOULDER, .38 DIA	5402861	1
38	PLATE - PRIMER LUBRICANT TANK	1963400	1
39	TANK - PRIMER, 4 QUART, W/CAP	4403703	1
40	TUBE - ROUND, 0.19 X 6', NEO	1101937	1

REVISIONS				
LTR	DESCRIPTION	DATE	CHG NO.	APPROV
A	3500021 WAS 1080530	12APR2012	8225	WAH
B	ADDED 1101937 AND 4403703	12APR2012	8225	WAH
C	ADDED 1963400	12APR2012	8225	WAH
D	5400118 WAS 5400109	02AUG2013	10235	SMS

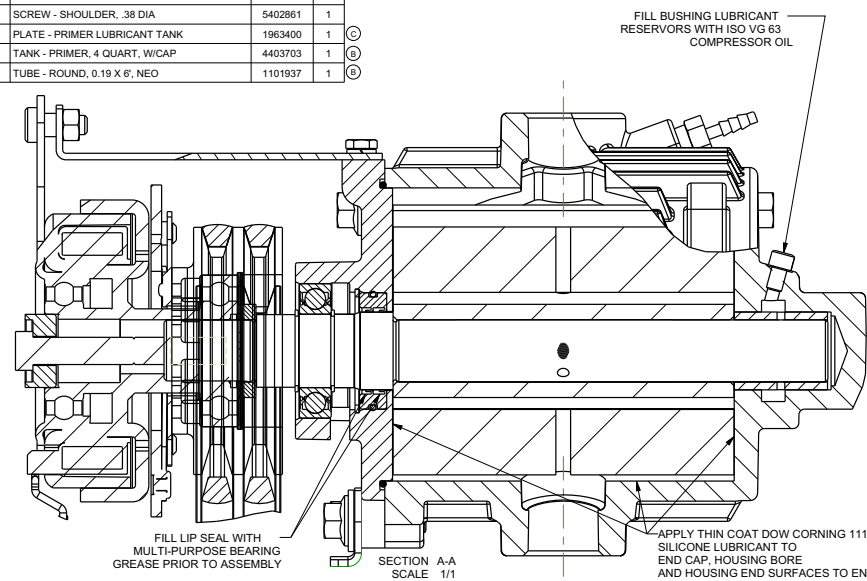
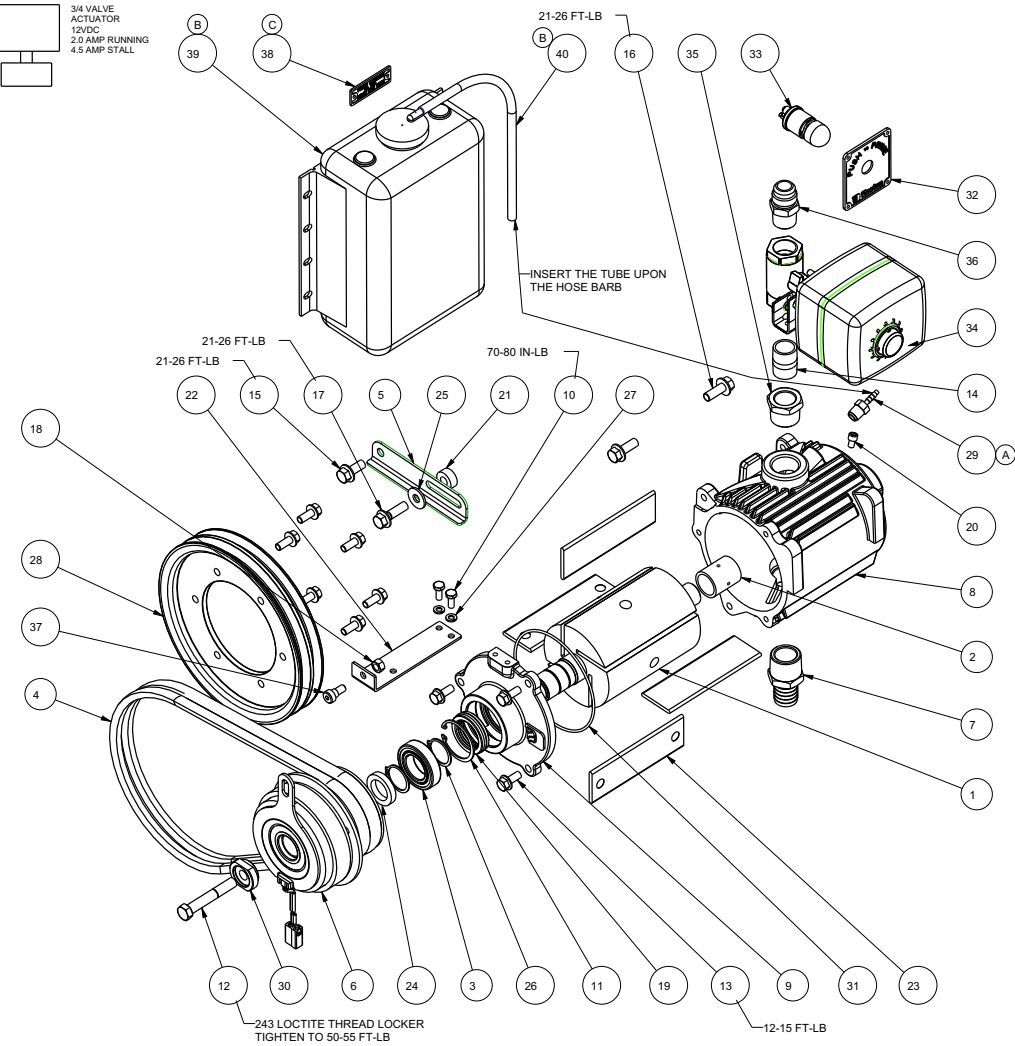
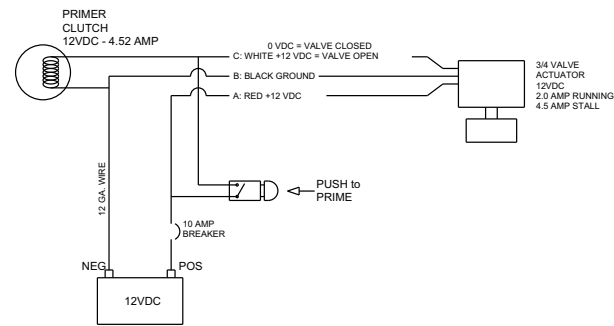

REMOVE SHARP EDGES		INCH [MILLIMETER]	OLD PART NO.	TOLERANCE EXPLODED	W.S. Darley Co.
MATERIAL DESCRIPTION			PATTERN NO.	PRIMER - BELT DRIVEN, 12VDC, R2 ZSP 2 GEAR, DARLEY	
THIS DESIGN IS THE PROPERTY OF W.S. DARLEY AND CO. UNAUTHORIZED REPRODUCTION IS PROHIBITED.		ALL DIMENSIONS IN INCHES UNLESS NOTED	DO NOT SCALE PRINT	DATE: 22-Feb-12	DVC0306
				SCALE: 3/8	

NO.	DESCRIPTION	PART NO.	QTY.
1	ASSY - ROTOR, BELT DRV, R2	4434320	1
2	BEARING - OILITE, 1.000 ID, PORTED	1762900	1
3	BEARING-BALL, 6006 2RSR,T	1724800	1
4	BELT - PRIMER DRIVE	4226901	2
5	BRACKET - CLUTCH ANTI-ROTATION	4038010	1
6	CLUTCH - VAC PUMP, 12VDC	4227001	1
7	FTG - BARB, 1.00 ID X 1.00 NPT MALE	3502031	1
8	CYLINDER - VAC PUMP, 25 CU IN, R2	1021101	1
9	HEAD - CYL, VAC PUMP, 25 CU IN, R2	2812901	1
10	HHCS - .25-20 X .83, GR 5 SST	5400603	2
11	RING - RETAINER, HO-187 SS	3600462	1
12	HHCS - .438-20 X 2.75, GR5	5400118	1
13	HHCS - FLANGED, .313-18 X .750	5402833	9
14	NIPPLE - PIPE, .75 X CLOSE, BR	1081048	1
15	HHCS - FLANGED, .375-16 X .88	5402835	1
16	HHCS - FLANGED, .375-16 X 1.00	5402845	2
17	HHCS - FLANGED, .375-16 X 1.25	5402856	1
18	NUT - HEX, .313-18, NYLOC, SST	5403400	1
19	SEAL - FURON MECHANICAL, 1.250	1843403	1
20	SHCS - .250-20 x 0.37 SST	5401400	1
21	SPACER - .406 X .88 X .38	3309000	1
22	STRAP - CLUTCH ANTI-ROTATION	4038110	1
23	VANE - ROTOR, 25 CU IN, .1905 THICK	4434200	4
24	WASHER - 1.00 x 1.50 x .273 SS	3603342	1
25	WASHER - FLAT, .375 ID	3603820	1
26	RING - RETAINER, SH-118 SS	3600450	2
27	WASHER - LOCK, 0.250 ID, SST	3603532	2
28	PULLEY - PRIMER DRIVE	4822600	1
29	TUBE FITTING - STR, .25 X .19	3500021	1
30	RETAINER - BEARING, PRIMER CLUTCH	2314400	1
31	O-RING - 4.75 x 4.94 x 0.09	3601114	1
32	PLATE - PRIMER, PUSH BUTTON	1978501	1
33	SWITCH - C7H, PUSH-BTN	2600008	1
34	VALVE - ACTUATED, 12/24VDC, .75NPT FE	5209404	1
35	BUSHING - PIPE, 1 x 0.75 BR	1080648	1
36	FITTING-.75NPTMx.75J/CM	3501553	1
37	SCREW - SHOULDER, .38 DIA	5402861	1
38	PLATE - PRIMER LUBRICANT TANK	1977106	1
39	TANK - PRIMER, 4 QUART, W/CAP	4403703	1
40	TUBE - ROUND, 0.19 X 6', NEO	1101937	1

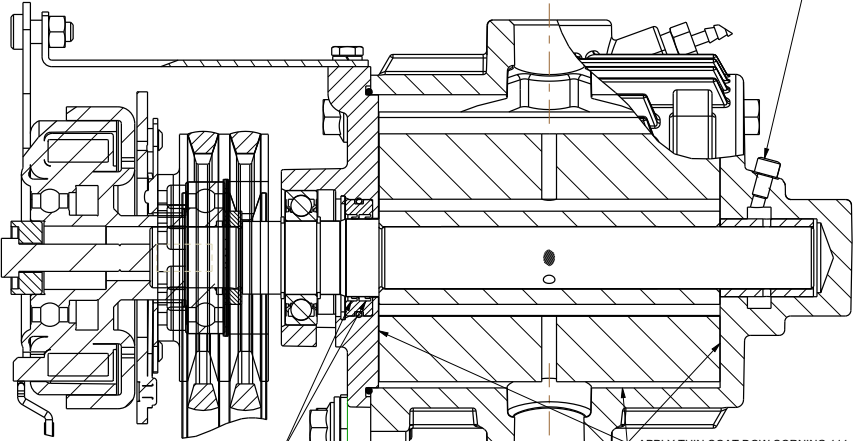
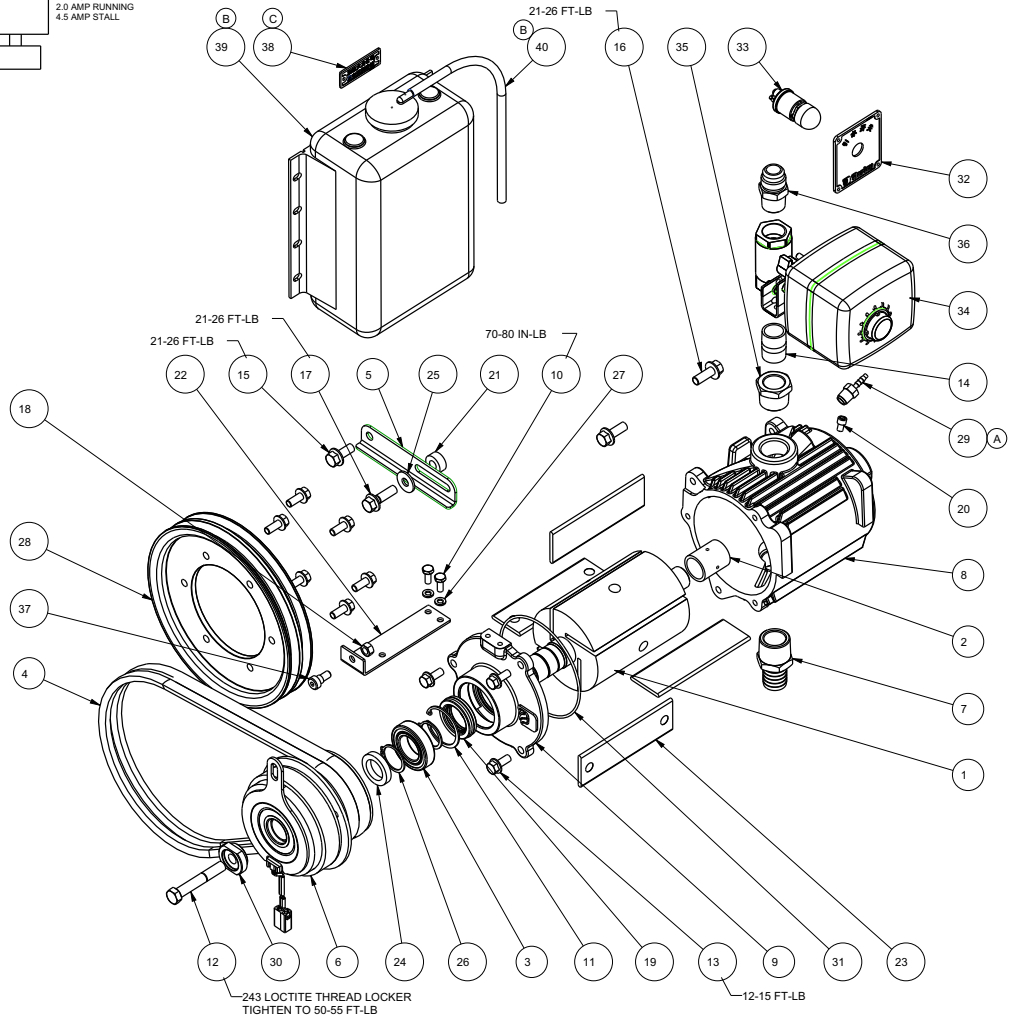
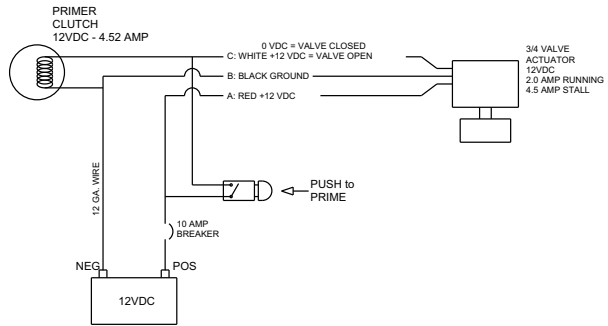

FILL BUSHING LUBRICANT RESERVOIRS WITH ISO VG 63 COMPRESSOR OIL

APPLY THIN COAT DOW CORNING 111 SILICONE LUBRICANT TO END CAP, HOUSING BORE AND HOUSING END SURFACES TO ENHANCE VANE SEAL

REVISIONS				
LTR	DESCRIPTION	DATE	CHG NO.	APPROV
A	3500021 WAS 1080530	12APR2012	8225	WAH
B	ADDED 191937 AND 4403703	12APR2012	8225	WAH
C	ADDED 1977106	12APR2012	8225	WAH
D	5400118 WAS 5400109	02AUG2013	10265	SMS

REMOVE SHARP EDGES

INCH [MILLIMETER]

OLD PART NO. AP02133 23-FEB-2012 1/11 D

TOLERANCE AS NOTED

W.S. DANEK Co.

PRIMER - BELT DRIVEN, 12VDC, R2 ZSP, 2 GEAR, CHINA

DATE 23-Feb-12

SCALE 3/8

DVC0307

NO.	DESCRIPTION	PART NO.	QTY.
1	ASSY - ROTOR, BELT DRV, R2	4434320	1
2	BEARING - OILITE, 1.000 ID, PORTED	1762900	1
3	BEARING-BALL, 6006 2RSR,T	1724800	1
4	BELT - PRIMER DRIVE	4226901	2
5	BRACKET - CLUTCH ANTI-ROTATION	4038010	1
6	CLUTCH - VAC PUMP, 24VDC	4227011	1
7	FTG - BARB, 1.00 ID X 1.00 NPT MALE	3502031	1
8	CYLINDER - VAC PUMP, 25 CU IN, R2	1021101	1
9	HEAD - CYL, VAC PUMP, 25 CU IN, R2	2812901	1
10	HHCS - .25-20 X .83, GR 5 SST	5400603	2
11	RING - RETAINER, HO-187 SS	3600462	1
12	HHCS - .438-20 X 2.75, GR5	5400118	1
13	HHCS - FLANGED, .313-18 X .750	5402833	9
14	NIPPLE - PIPE, .75 X CLOSE, BR	1081048	1
15	HHCS - FLANGED, .375-16 X .88	5402835	1
16	HHCS - FLANGED, .375-16 X 1.00	5402845	2
17	HHCS - FLANGED, .375-16 X 1.25	5402856	1
18	NUT - HEX, .313-18, NYLOC, SST	5403400	1
19	SEAL - FURON MECHANICAL, 1.250	1843403	1
20	SHCS - .250-20 x 0.37 SST	5401400	1
21	SPACER - .408 X .88 X .38	3390900	1
22	STRAP - CLUTCH ANTI-ROTATION	4038110	1
23	VANE - ROTOR, 25 CU IN, .1905 THICK	4434200	4
24	WASHER - 1.00 x 1.50 x .273 SS	3603342	1
25	WASHER - FLAT, .375 ID	3603820	1
26	RING - RETAINER, SH-118 SS	3600450	2
27	WASHER - LOCK, 0.250 ID, SST	3603532	2
28	PULLEY - PRIMER DRIVE	4822600	1
29	TUBE FITTING - STR, .25 X .19	3500021	1
30	RETAINER - BEARING, PRIMER CLUTCH	2314400	1
31	O-RING - 4.75 x 4.94 x 0.09	3601114	1
32	PLATE - PRIMER, PUSH BUTTON	1978500	1
33	SWITCH - C7H, PUSH-BTN	2600008	1
34	VALVE - ACTUATED, 12/24VDC, .75NPT FE	5209404	1
35	BUSHING - PIPE, 1 x 0.75 BR	1080648	1
36	FITTING-.75NPTMx.75JICM	3501553	1
37	SCREW - SHOULDER, .38 DIA	5402861	1
38	PLATE - PRIMER LUBRICANT TANK	1963400	1
39	TANK - PRIMER, 4 QUART, W/CAP	4403703	1
40	TUBE - ROUND, 0.19 X 6', NEO	1101937	1

REVISIONS				
LTR	DESCRIPTION	DATE	CHG NO.	APPROV
A	ISSUED WAS 1080530	12APR2012	8225	WAH
B	ADDED 101937 AND 4403703	12APR2012	8225	WAH
C	ADDED 1963400	12APR2012	8225	WAH
D	5400118 WAS 5400109	02AUG2013	10265	SMS

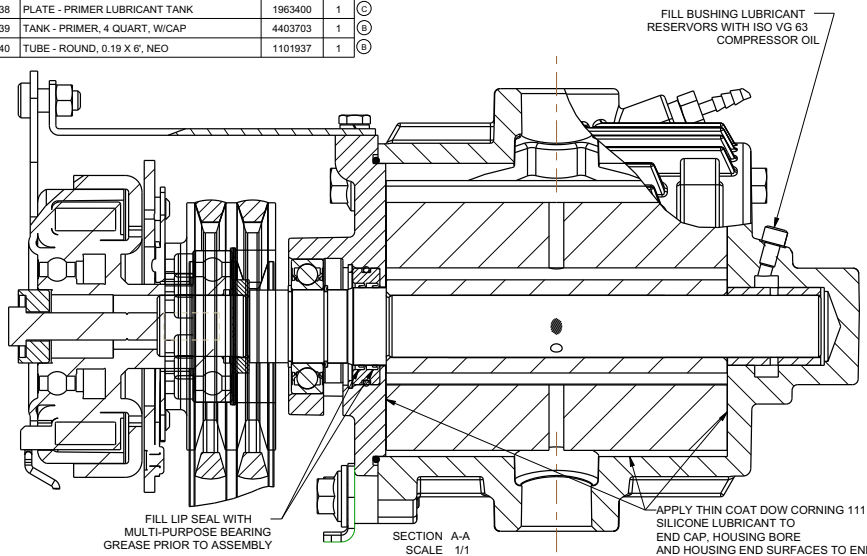
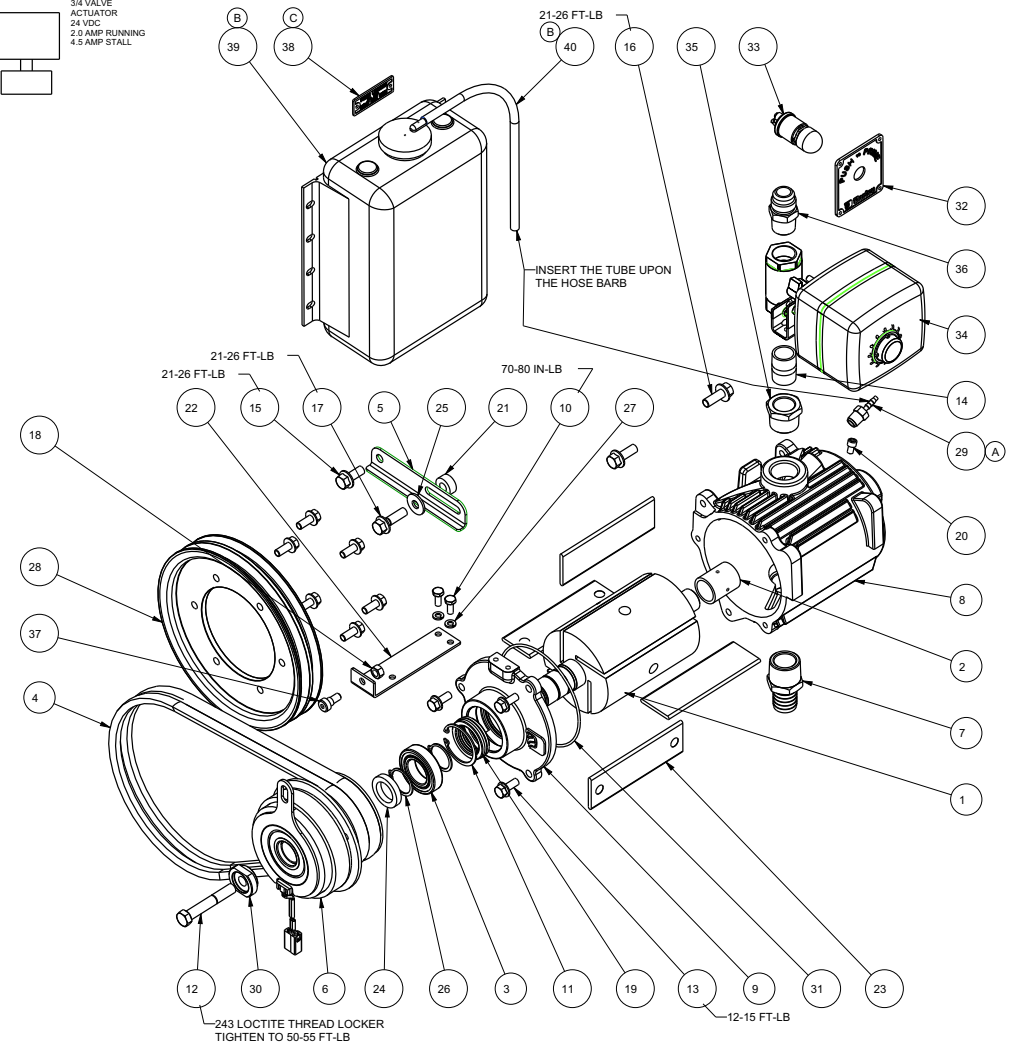
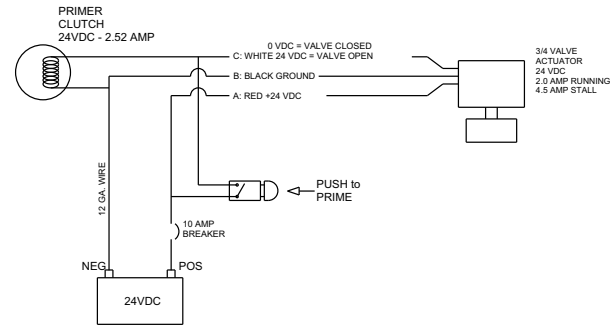

REMOVE SHARP EDGES

INCH (MILLIMETER)

OLD PART NO. APO2142

TOLERANCE EXPLODED AS NOTED

MATERIAL NO. PATTERN NO.

DATE 22-Feb-12

SCALE 3/8

W.S. Darley Co.

PRIMER - BELT DRIVEN, 24VDC, R2 ZSP, 2 GEAR, DARLEY

DVC0308



NO.	DESCRIPTION	PART NO.	QTY.
1	ASSY - ROTOR, BELT DRV, R2	4434320	1
2	BEARING - OILITE, 1.000 ID, PORTED	1762900	1
3	BEARING-BALL, 6006 2RSR,T	1724800	1
4	BELT - PRIMER DRIVE	4226901	2
5	BRACKET - CLUTCH ANTI-ROTATION	4038010	1
6	CLUTCH - VAC PUMP, 24VDC	4227011	1
7	FTG - BARB, 1.00 ID X 1.000 NPT MALE	3502031	1
8	CYLINDER - VAC PUMP, 25 CU IN, R2	1021101	1
9	HEAD - CYL, VAC PUMP, 25 CU IN, R2	2812901	1
10	HHCS - .25-20 X .83, GR 5 SST	5400603	2
11	RING - RETAINER, HO-187 SS	3600462	1
12	HHCS - .438-20 x 2.75, GR5	5400118	1
13	HHCS - FLANGED, .313-18 X .750	5402833	9
14	NIPPLE - PIPE, .75 X CLOSE, BR	1081048	1
15	HHCS - FLANGED, .375-16 X .88	5402835	1
16	HHCS - FLANGED, .375-16 X 1.00	5402845	2
17	HHCS - FLANGED, .375-16 X 1.25	5402856	1
18	NUT - HEX, .313-18, NYLOC, SST	5403400	1
19	SEAL - FURON MECHANICAL, 1.250	1843403	1
20	SHCS - .250-20 x 0.37 SST	5401400	1
21	SPACER - .406 X .88 X .38	3309000	1
22	STRAP - CLUTCH ANTI-ROTATION	4038110	1
23	VANE - ROTOR, 25 CU IN, 1.905 THICK	4434200	4
24	WASHER - 1.00 x 1.50 x .273 SS	3603342	1
25	WASHER - FLAT, .375 ID	3603820	1
26	RING - RETAINER, SH-118 SS	3600450	2
27	WASHER - LOCK, 0.250 ID, SST	3603532	2
28	PULLEY - PRIMER DRIVE	4822600	1
29	TUBE FITTING - STR, .25 X .19	3500021	1
30	RETAINER - BEARING, PRIMER CLUTCH	2314400	1
31	O-RING - 4.75 x 4.94 x 0.09	3601114	1
32	PLATE - PRIMER, PUSH BUTTON	1978501	1
33	SWITCH - C7H, PUSH-BTN	2600008	1
34	VALVE - ACTUATED, 12/24VDC, .75NPT FE	5209404	1
35	BUSHING - PIPE, 1 x 0.75 BR	1080648	1
36	FITTING-75NPTMx.75JICM	3501553	1
37	SCREW - SHOULDER, .38 DIA	5402861	1
38	PLATE - PRIMER LUBRICANT TANK	1977106	1
39	TANK - PRIMER, 4 QUART, W/CAP	4403703	1
40	TUBE - ROUND, 0.19 X 6', NEO	1101937	1

REVISIONS				
LTR	DESCRIPTION	DATE	CHG NO.	APPROV
A	3500021 WAS 1080535	12APR2012	8225	WAH
B	ADDED 1101937 AND 4403703	12APR2012	8225	WAH
C	ADDED 1977106	12APR2012	8225	WAH
D	5400118 WAS 5400109	02AUG2013	10265	SMS

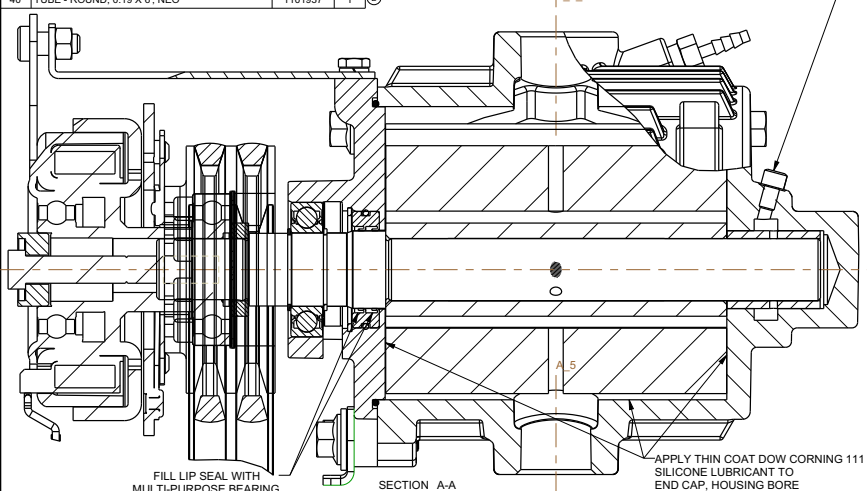
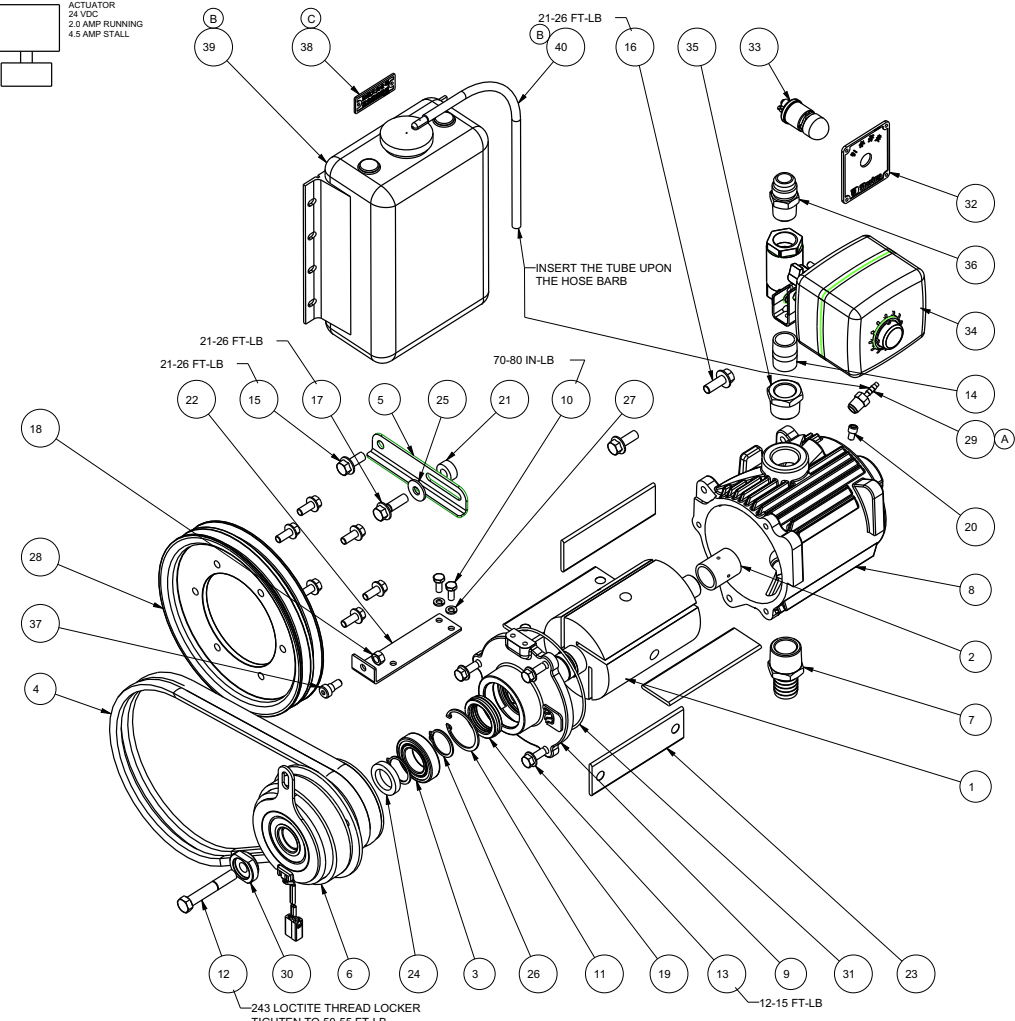
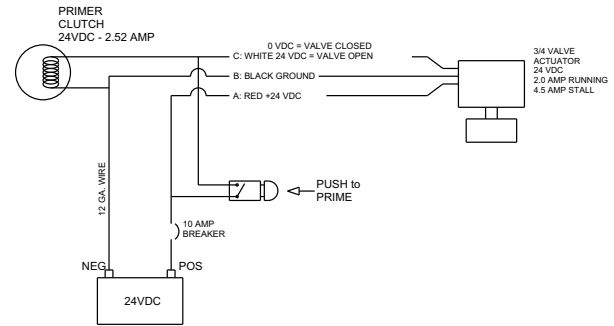

REMOVE SHARP EDGES		INCH (MILLIMETER)	OLD PART NO.	TOLERANCE EXP. NOTED	W.S. DANEK Co.
MATERIAL DESCRIPTION			PATTERN NO.	DATE: 22-Feb-12	DVC0309
THIS DESIGN IS THE PROPERTY OF W.S. DANEK AND IS UNAUTHORIZED REPRODUCTION IS PROHIBITED.		ALL DIMENSIONS IN INCHES UNLESS NOTED	DO NOT SCALE PRINT	SCALE: 3/8	

NO.	DESCRIPTION	PART NO.	QTY.
1	ASSY - ROTOR, 25 CU IN VAC PUMP	4434312	1
2	BEARING - OILITE, 1.000 ID	1760006	1
3	BEARING - OILITE, 1.250 ID	1760033	1
4	BELT - PRIMER DRIVE	4226900	2
5	BRACKET - CLUTCH ANTI-ROTATION	4038010	1
6	BUSHING - PIPE, 1 x 0.75 BR	1080648	1
7	CLUTCH - VAC PUMP, 24VDC	4227011	1
8	CYLINDER - VACUUM PUMP, 25 CU IN	1021200	1
9	FITTING-75NPTMx.75JICM	3501553	2
10	FTG - BARB, 1.00 ID X 1.00 NPT MALE	3502031	1
11	HHCS - 25-20 X .63, GR 5 SST	5400603	2
12	HHCS - .313-18 X 0.75, SST	5400641	1
13	HHCS - 438-20 X 2.75, GR5	5400118	1
14	HHCS - FLANGED, .313-18 X .750	5402833	6
15	HHCS - FLANGED, .313-18 X .875	5402831	3
16	HHCS - FLANGED, .375-16 X .88	5402835	1
17	HHCS - FLANGED, .375-16 X 1.00	5402845	2
18	HHCS - FLANGED, .375-16 X 1.25	5402856	1
19	NIPPLE - PIPE, .75 X CLOSE, BR	1081048	1
20	NUT - HEX, .313-18, NYLOC, SST	5403400	1
21	O-RING - 4.75 x 4.94 x 0.09	3601114	1
22	PLATE - PRIMER, PUSH BUTTON	1978500	1
23	PLATE - PRIMER LUBRICANT TANK	1963400	1
24	PULLEY - PRIMER DRIVE	4822600	1
25	R.C. - CYL HD, VAC PUMP, 25 CU IN	2813800	1
26	RETAINER - BEARING, PRIMER CLUTCH	2314400	1
27	SEAL - FURON MECHANICAL, 1.250	1843403	1
28	SHCS - .250-20 x 0.37 SST	5401400	1
29	SPACER - 406 X .88 X .38	3309000	1
30	STRAP - CLUTCH ANTI-ROTATION	4038110	1
31	SWITCH - C7H, PUSH-BTN	2600008	1
32	TANK - PRIMER, 4 QUART, W/CAP	4403703	1
33	TUBE - PRIMER CONNECT	4434800_ZSP	1
34	TUBE - ROUND, 0.19 X 6", NEO	1101937	1
35	TUBE FITTING - STR, .25 X .19	3500021	1
36	VALVE - ACTUATED, 12/24VDC, .75NPT FE	5209404	1
37	VANE - ROTOR, 25 CU IN, 1905 THICK	4434200	4
38	WASHER - 1.00 x 1.50 x .273 SS	3603342	1
39	WASHER - FLAT, .375 ID	3603820	1
40	WASHER - FLAT, 0.31 ID, SST	3603812	1
41	WASHER - LOCK, 0.250 ID, SST	3603532	2

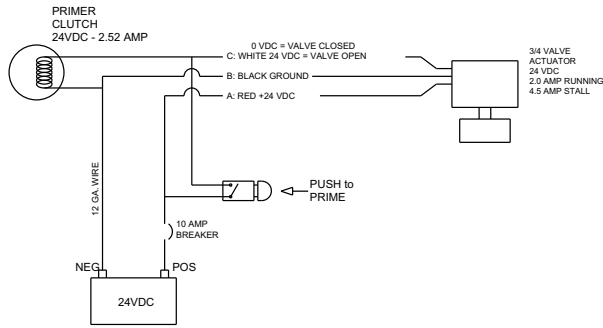

NOTES:  
 1) TIGHTEN A NEW BELT UNTIL THERE IS 30 TO 60 LBF STATIC TENSION PER BELT. THIS CORRESPONDS TO A 2.2 TO 4.1 LBF DEFLECTION FORCE RESULTING IN A .16 INCH DEFLECTION AT THE BELT MIDSPAN.  
 REFERENCE NOTES:  
 1) THE BELTS ARE CAPABLE OF TRANSMITTING 11.28 HP AT 1000 RPM DRIVELINE SPEED.  
 2) THE IS A 2.1998:1 SPEED INCREASE BETWEEN THE DRIVELINE AND THE PRIMER.  
 3) IF A GATES 907C SINIC TENSION METER IS USED, SET WEIGHT TO 114.2, WIDTH TO 1 AND SPAN TO 267.0. THE DESIRED FREQUENCY IS 64 TO 90 HZ WHEN THE BELT IS NEW AND 59 TO 84 HZ WHEN THE BELT IS USED.

REVISIONS				
LTR	DESCRIPTION	DATE	CHG NO.	APPROV
A	5400118 WAS 5402109	02AUG2013	10265	SMS

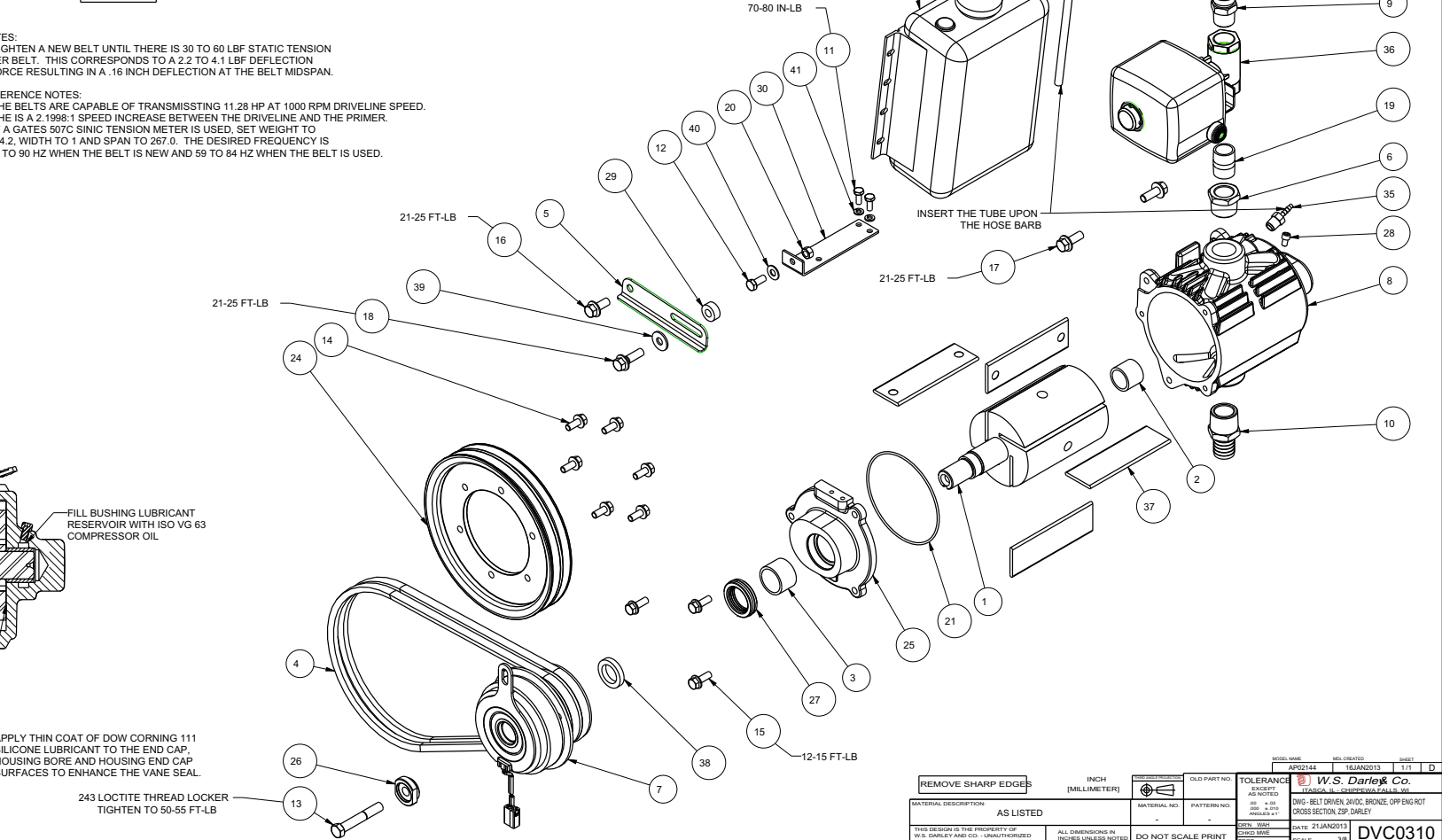

REMOVE SHARP EDGES	INCH (MILLIMETER)	OLD PART NO.	TOLERANCE (SEE NOTES)	W.S. DANEK Co.
MATERIAL DESCRIPTION	AS LISTED	MATERIAL NO.	PATTERN NO.	DWG - BELT DRIVEN, 24VDC, BRONZE, OFF ENG ROT CROSS SECTION, ZSP, DARLEY
THIS DESIGN IS THE PROPERTY OF W.S. DANEK AND IS UNAUTHORIZED REPRODUCTION IS PROHIBITED.		ALL DIMENSIONS IN INCHES UNLESS NOTED		DO NOT SCALE PRINT
DATE: 21JAN2013		SCALE: 3/8		DVC0310



# ***PUMP DRAWINGS***

Prepared by: RJG  
Approved by: WAH  
Revised by: WAH Via ECO 11337

Rev. A  
Date: 03/16/12  
Rev. Date: 02/19/2016  
1200643.doc

NO.	DESCRIPTION	PART NO.	QTY.
1	BEARING - 22311E C3	1726100	1
2	FHMS - .250-20 x 0.63, SS	5402402	4
3	FTG - 1.00 ORB MALE X -06 JIC MALE	3501574	2
4	HEAD - INBOARD, ZS	2812600	1
5	HEAD - SUCTION, ZS	2812700	1
6	HEX NUT - .500-13, GR 2	5403005	32
7	HHCS - FLANGED, .500-13 X 1.75	5402853	2
8	HOUSING - MECHANICAL SEAL, ZS	1846200	1
9	IMPELLER - ZS, R.H.	2908700	1
10	MECHANICAL SEAL - 2.00", ZS	1846300	1
11	NUT - IMPELLER, CONE, ZS	5403477	1
12	O-RING - 1.47 x 1.71 x 0.09	3601401	1
13	O-RING - 13.00 x 12.75 x 0.12	3601272	3
14	O-RING - 3.75 x 3.94 X 0.09	3601133	2
15	O-RING - 5.25 x 5.50 x 0.12	3601232	1
16	OIL SEAL - 2.125 ID X 3.000 OD	3600571	1
17	PIN - COTTER, .125 x 2.00, SST	3605207	1
18	PLUG - 1 5/16-12 SAE ORB, HEX SOC	3501575	1
19	PLUG - PIPE, 0.125, SST SOC HD	1080533	1
20	PLUG - PIPE, 0.250, SST SOC HD	1080535	5
21	PLUG - PIPE, 0.750 SST SQ HD	1080543	1
22	PLUG - PIPE, 0.750, SST SOC HD	1080551	3
23	PUMP CASING - ZS	2056400	1
24	SCREEN STRAINER	1122400	1
25	SEAL RING - ZS	3407500	2
26	SHAFT - IMPELLER, ZS	5022400	1
27	SLINGER - WATER, ZS, 1.894 ID	3203210	1
28	STRAINER - FITTING	1122300	1
29	STUD - 0.500-13 X 2.000, GR5	3606402	32

REF ONLY  
REF ONLY

B  
B

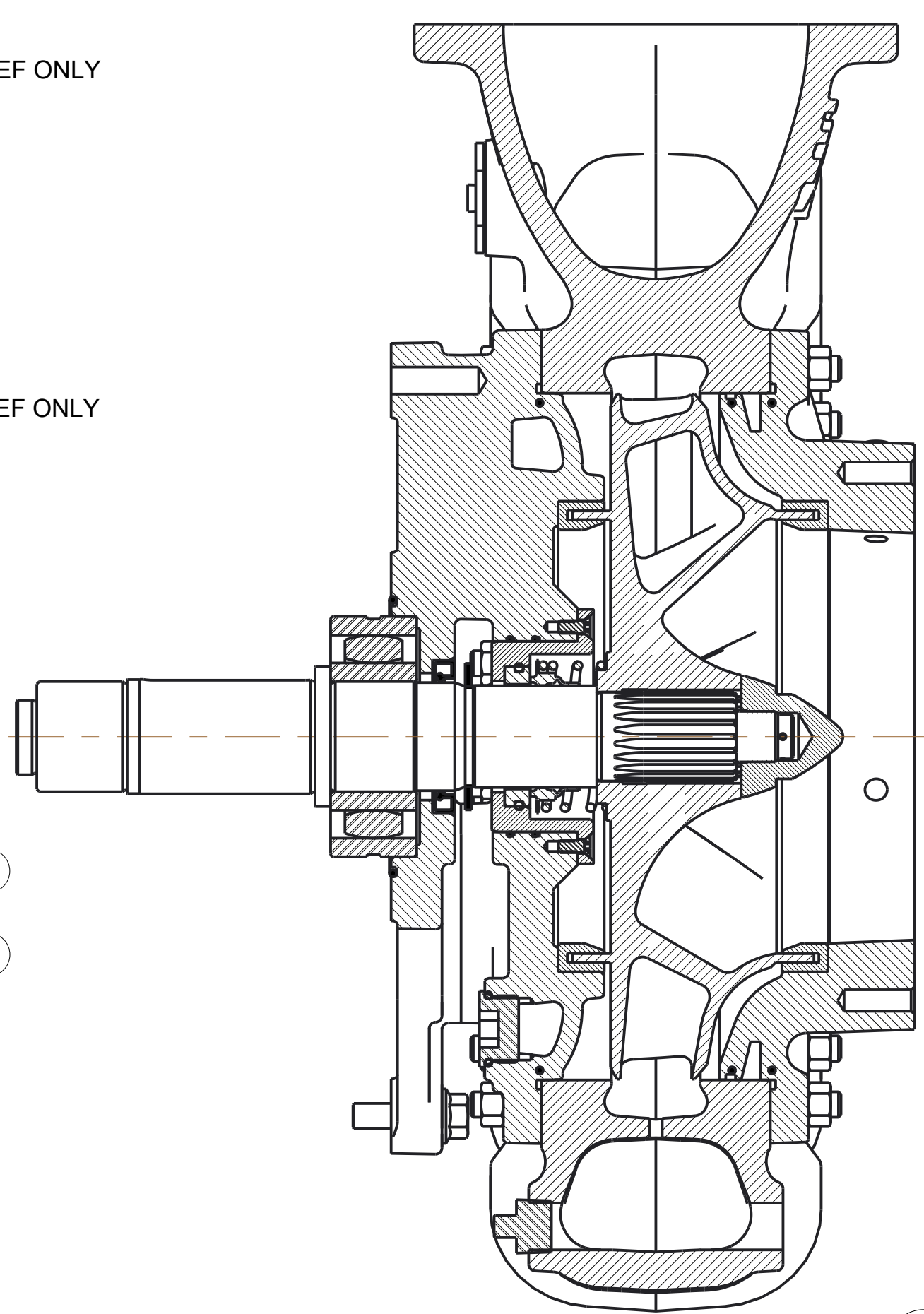

REVISIONS				
LTR	DESCRIPTION	DATE	CHG NO.	APPRD
A	REMOVED 3601707 O-RINGS	20APR2012	8284	WAH
B	ADDED 3/4 AND 1/4 NPT PLUGS	12MAR2014	10459	WAH

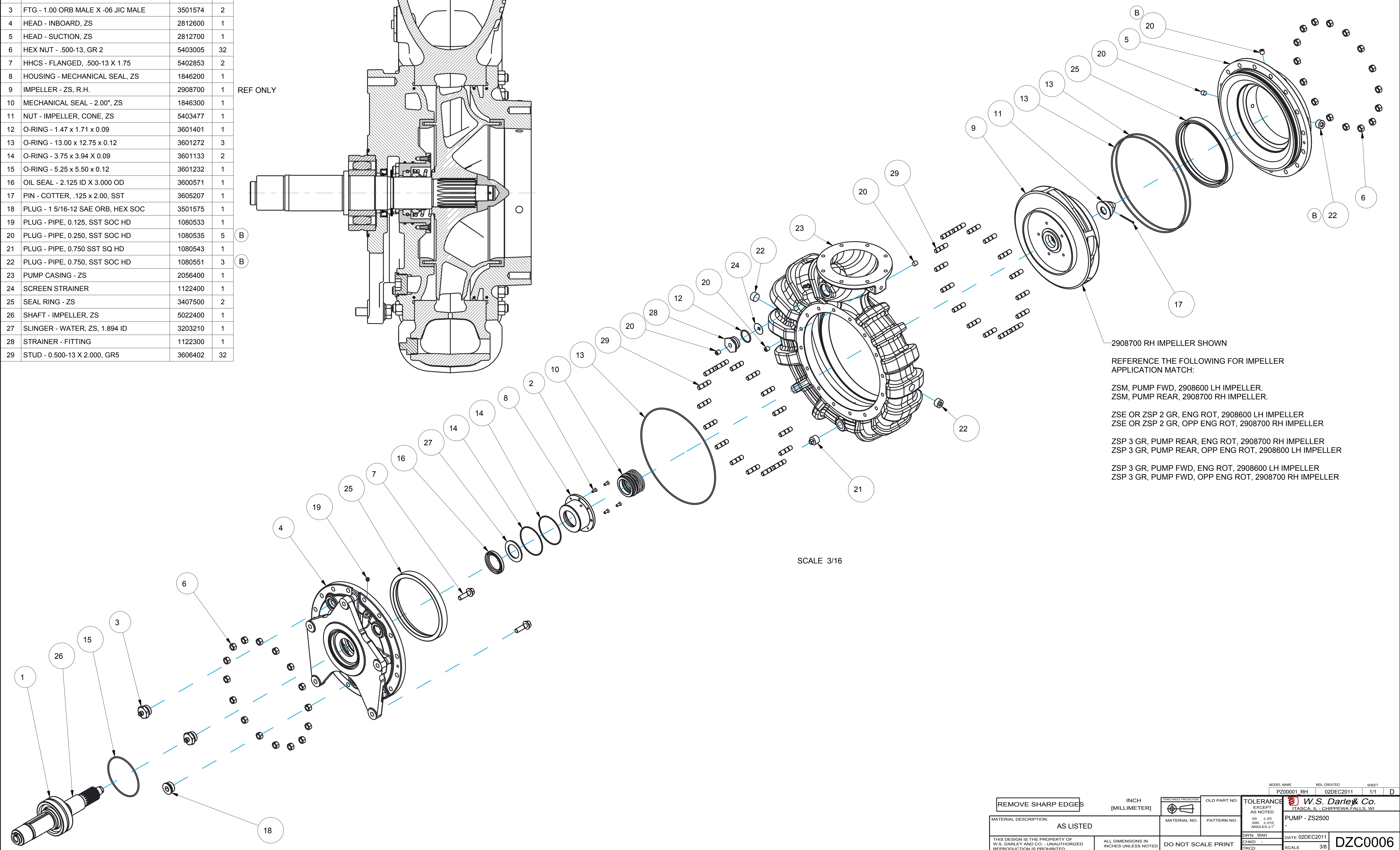

2908700 RH IMPELLER SHOWN

REFERENCE THE FOLLOWING FOR IMPELLER APPLICATION MATCH:

ZSM, PUMP FWD, 2908600 LH IMPELLER.  
ZSM, PUMP REAR, 2908700 RH IMPELLER.

ZSE OR ZSP 2 GR, ENG ROT, 2908600 LH IMPELLER  
ZSE OR ZSP 2 GR, OPP ENG ROT, 2908700 RH IMPELLER

ZSP 3 GR, PUMP REAR, ENG ROT, 2908700 RH IMPELLER  
ZSP 3 GR, PUMP REAR, OPP ENG ROT, 2908600 LH IMPELLER

ZSP 3 GR, PUMP FWD, ENG ROT, 2908600 LH IMPELLER  
ZSP 3 GR, PUMP FWD, OPP ENG ROT, 2908700 RH IMPELLER

SCALE 3/16

REMOVE SHARP EDGES		INCH (MILLIMETER)	OLD PART NO.	TOLERANCE EXCEPT AS NOTED	W.S. Darley & Co. ITASCA, IL - CHIPPEWA FALLS, WI
MATERIAL DESCRIPTION: AS LISTED			MATERIAL NO.	PATTERN NO.	PUMP - ZS2500
THIS DESIGN IS THE PROPERTY OF W.S. DARLEY AND CO. - UNAUTHORIZED REPRODUCTION IS PROHIBITED		ALL DIMENSIONS IN INCHES UNLESS NOTED	DO NOT SCALE PRINT	DRN: WAH CHKD: TRCD:	DATE 02DEC2011 SCALE 3/8

DZC0006



NO.	DESCRIPTION	PART NO.	QTY.
1	BEARING - 22211E C3	1726300	2
2	FHMS - .250-20 x 0.63, SS	5402402	4
3	FTG - 1.00 ORB MALE X -06 JIC MALE	3501574	2
4	HEAD - INBOARD, ZS	2812600	1
5	HEAD - SUCTION, ZS	2812700	1
6	HEX NUT - .500-13, GR 2	5403005	30
7	HHCS - FLANGED, .500-13 X 1.75	5402853	2
8	HOUSING - MECHANICAL SEAL, ZS	1846200	1
9	BEARING - 22311E C3	1726100	1
10	MECHANICAL SEAL - 2.00", ZS	1846300	1
11	NUT - IMPELLER, CONE, ZS	5403477	1
12	O-RING - 1.47 x 1.71 x 0.09	3601401	1
13	O-RING - 13.00 x 12.75 x 0.12	3601272	3
14	O-RING - 3.75 x 3.94 X 0.09	3601133	2
15	O-RING - 5.25 x 5.50 x 0.12	3601232	2
16	OIL SEAL - 2.125 ID X 3.000 OD	3600571	1
17	PIN - COTTER, .125 x 2.00, SST	3605207	1
18	PLUG - 1 5/16-12 SAE ORB, HEX SOC	3501575	3
19	PLUG - PIPE, 0.125, SST SOC HD	1080533	1
20	PLUG - PIPE, 0.250, SST SOC HD	1080535	5
21	PLUG - PIPE, 0.750 SST SQ HD	1080543	1
22	PLUG - PIPE, 0.750, SST SOC HD	1080551	3
23	PUMP CASING - ZS	2056400	1
24	SCREEN STRAINER	1122400	1
25	SEAL RING - ZS	3407500	2
26	SHAFT - IMPELLER, ZS	5022400	1
27	SLINGER - WATER, ZS, 1.894 ID	3203210	1
28	STRAINER - FITTING	1122300	1
29	STUD - 0.500-13 X 2.000, GR5	3606402	30
30	BEARING - BALL, 6311.C3	1725900	1
31	CAP - BEARING, IMPELLER, ZSE	2313303	1
32	CAP - BRG, INPUT, REAR, ZSE	2314701	1
33	CAP - BRG, INPUT, ZSE 2 GEAR	2314501	1
34	COMP FLANGE - 1550	4822510	1
35	COVER - OIL SUMP, ZSE 2 GEAR	2509200	1
36	DIPSTICK - -10 MORB PORT	4229104	1
37	FILTER - LUBE PUMP, 100 MESH	1124301	1
38	FTG - .38 JIC FE X .38 JIC MALE X 90	3501596	2
39	FTG - .38 JICM X 9/16-18, SAE ORB	3501567	1
40	FTG - .38 JICM X 9/16-18, SAE ORB	3501576	1
41	FTG - BRANCH TEE ADJUSTABLE, .38	3501609	1
42	FTG-88JICM RIGX.75MORB SVL 90	3501639	1
43	FTG-.88MORB RIGIDX1/8NPT FEMAL	3501634	1
44	GEAR - DRIVE, 51T, 6DP, RH, PTO	2719305	1
45	GEAR - PINION, 6 DP, LH, 29 T	2720410	1
46	GEARCASE - 2 GEAR ZSE	1806300	1
47	HHCS - .625-11 x 8.00, GR5	5400108	3
48	HHCS - FLANGED, .313-18 X 1.25	5402844	4
49	HHCS - FLANGED, .375-16 X 1.25	5402856	8
50	HHCS - FLANGED, .375-16 X 1.50	5402860	4
51	IMPELLER - ZS, L.H.	2908600	1
52	KEY - SQ., 0.38 X 3.00	3602407	1
53	KEY - SQ., 0.50 x 3.00	3602456	1
54	KIT-MOUNTING, ZSF SUCTION HEAD	KM02102	1
55	KIT-MOUNTING, ZSP GEAR CASE	KM02103	1
56	METAL TACK, 3/16 HEAD, .025 L	5402873	2
57	NUT - FLANGE, 1.2500-12 UNJF-3B	4822300	1
58	O-RING - 0.75 x 0.94 x 0.09	3601138	1
59	O-RING - 3.88 x 4.12 x .12	3601252	1
60	O-RING - 4.12 x 4.38 x 0.12	3601217	1
61	O-RING - 9.50 x 9.25 x 0.12	3601269_FORMED1	1
62	OIL SEAL - 2.750 ID X 3.505 OD	3600511	1
63	PIN - DOWEL, .375 X 0.625, GR8	3605410	2
64	PIN - DOWEL, 0.156 x 0.50, GR8	3605407	1
65	PLATE - SERIAL NO., .COM	1963109	1
66	PLUG - 3/4-16 SAE ORB, HEX SOC	3501573	3
67	PLUG - 7/16-20 SAE ORB, HEX SOC	3501629	2
68	PLUG - 7/8-14 SAE ORB, HEX SOC	3501632	3
69	PLUG - 9/16-18 SAE ORB, HEX SOC	3501578	1
70	PLUG - MAGNETIC, 3/4-16UNF	1080545	1
71	PLUG - PIPE, 0.125, W/.125 THRU	1080553	3
72	PRIMER - BELT DRV, 24V, ENG	AP02400	1
73	PUMP - HYD, INTERNAL GEAR, LUBE	4821020	1
74	SHAFT - INPUT, 2 GR ZSP	5023700	1
75	SLEEVE - MEGATRANS, OIL PUMP	1887400	1
76	SPACER - 2.17 X 2.62 X .513	3309301	1
77	SPACER - 2.17 x 2.63 x .611	3305202	1
78	SPRING CARTRIDGE - OIL PUMP	4821100	1
79	TUBE - LUBE PUMP DISCH, ZSE	4434153	1
80	TUBE - LUBE PUMP DISCH, ZSE	4434154	1
81	TUBE - LUBE PUMP DISCH, ZSE	4434155	1
82	TUBE - LUBE PUMP SUCTION, ZSE	4432160	1
83	VENT - GEARCASE, 1/8 NPT MALE	4401801	1
84	WASHER - FLAT, .641 X 1.303 X .160	3603825	3
85	O-RING - .644 x .818 x 0.087	3601900	1

REVISIONS				
LTR	DESCRIPTION	DATE	CHG NO.	APPRD
A	3601900 WAS 3601138	30JUL2015	11080	SMS
B	ADDED 1 - 3501573	15JAN2016	11275	WAH

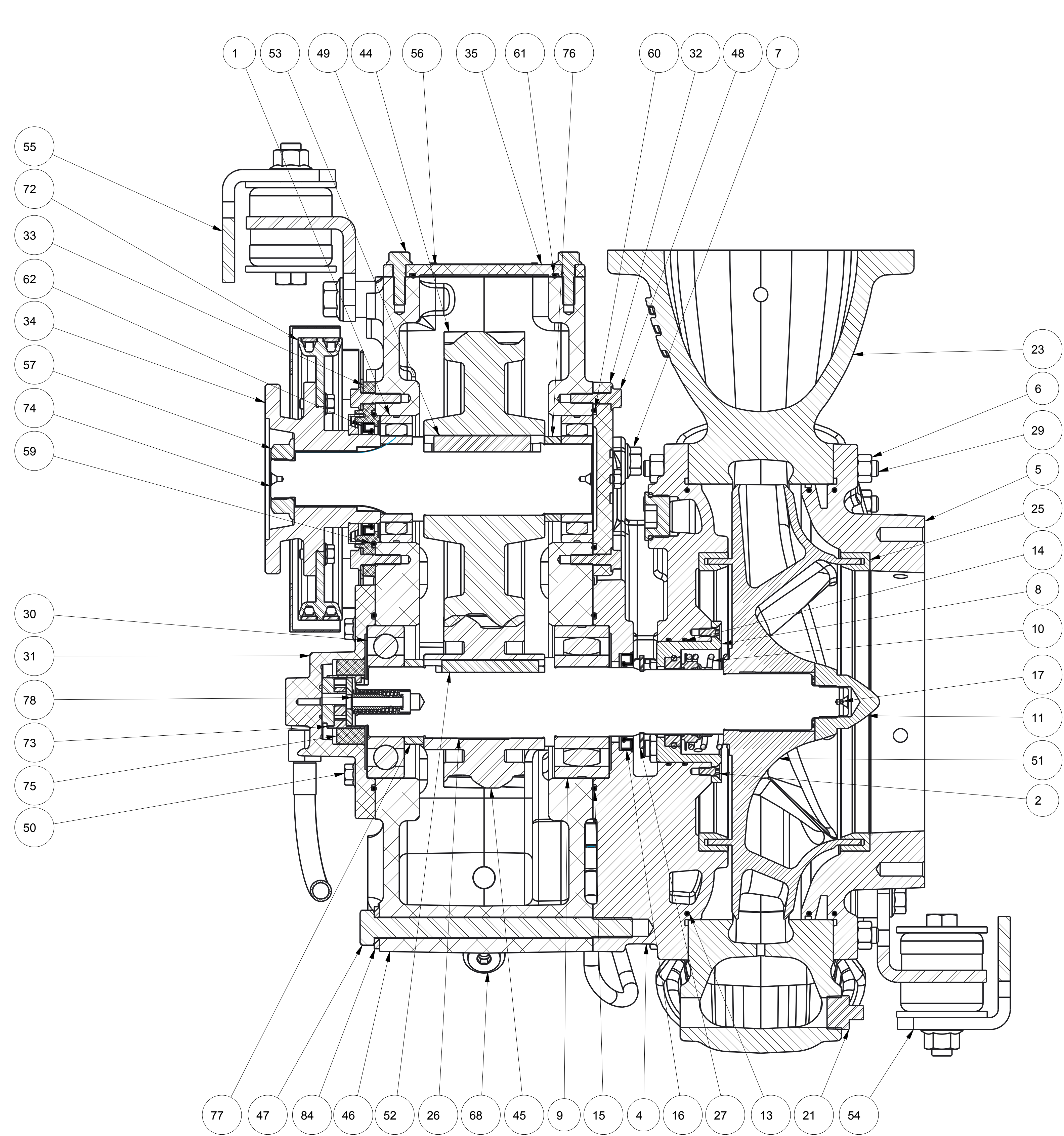

SECTION A-A

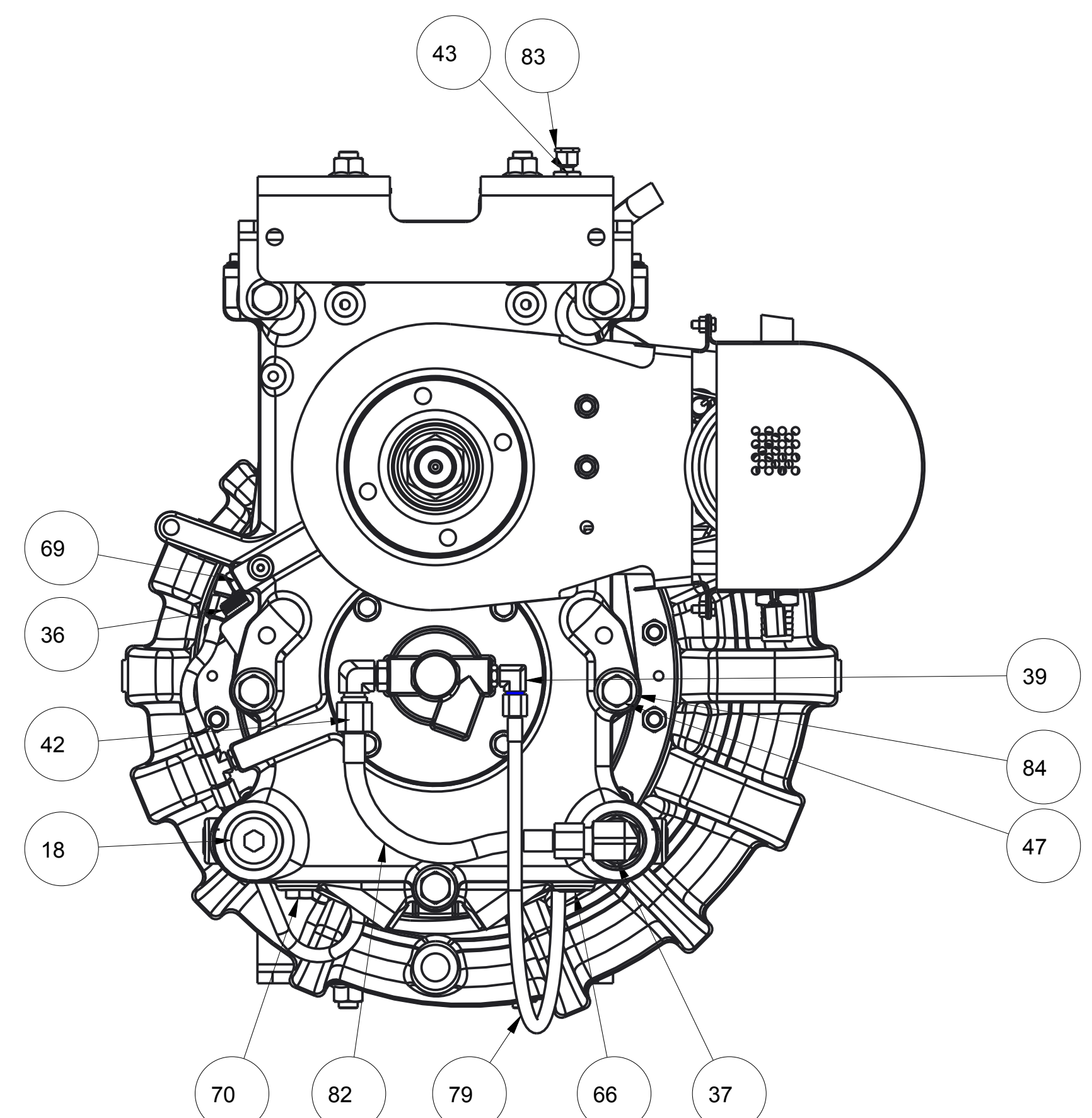

SCALE 1/4

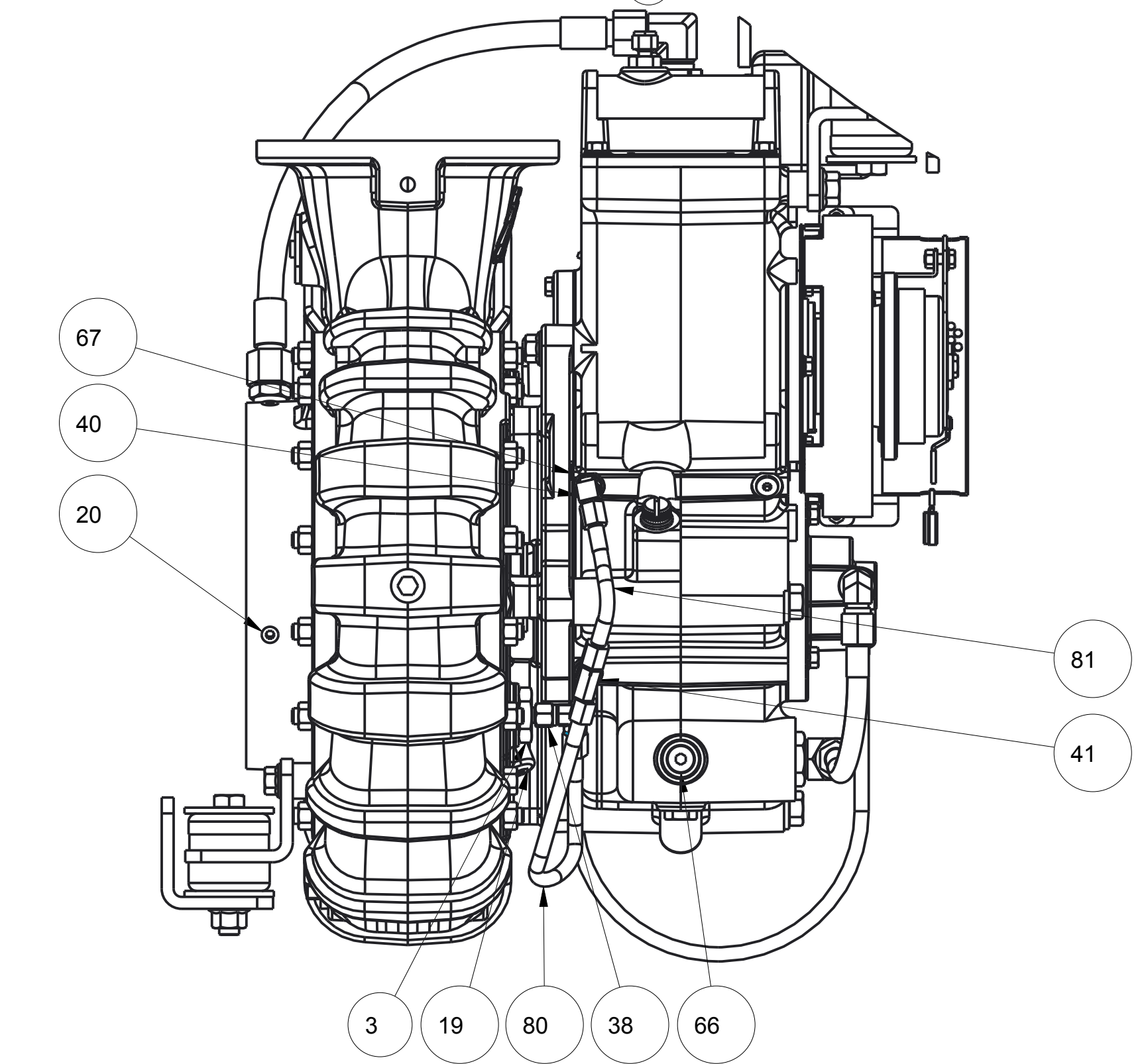

MODEL NAME: DZC0019 MDL CREATED: 10JUL2014 SHEET: 1/2 D

REMOVE SHARP EDGES	INCH (MILLIMETER)	OLD PART NO.	TOLERANCE EXCEPT AS NOTED 00 ±.03 2000 ±.010 ANGLES ±1°	W.S. Darley & Co. ITASCAL, IL - CHIPPewa FALLS, WI
MATERIAL DESCRIPTION: AS LISTED		MATERIAL NO.	PATTERN NO.	DWG - ZSP, INPUT ABOVE CROSS SECTION
THIS DESIGN IS THE PROPERTY OF W.S. DARLEY AND CO. - UNAUTHORIZED REPRODUCTION IS PROHIBITED	ALL DIMENSIONS IN INCHES UNLESS NOTED	DO NOT SCALE PRINT	DRN: SMS CHKD: WAH TRCD	DATE: 09-Jul-14 SCALE: 1/2

DZC0019



NO.	DESCRIPTION	PART NO.	QTY.
1	BEARING - 22211E C3	1726300	2
2	FHMS - .250-20 x 0.63, SS	5402402	4
3	FTG - 1.00 ORB MALE X -06 JIC MALE	3501574	2
4	HEAD - INBOARD, ZS	2812600	1
5	HEAD - SUCTION, ZS	2812700	1
6	HEX NUT - .500-13, GR 2	5403005	30
7	HHCS - FLANGED, .500-13 X 1.75	5402853	2
8	HOUSING - MECHANICAL SEAL, ZS	1846200	1
9	BEARING - 22311E C3	1726100	1
10	MECHANICAL SEAL - 2.00", ZS	1846300	1
11	NUT - IMPELLER, CONE, ZS	5403477	1
12	O-RING - 1.47 x 1.71 x 0.09	3601401	1
13	O-RING - 13.00 x 12.75 x 0.12	3601272	3
14	O-RING - 3.75 x 3.94 X 0.09	3601133	2
15	O-RING - 5.25 x 5.50 x 0.12	3601232	2
16	OIL SEAL - 2.125 ID X 3.000 OD	3600571	1
17	PIN - COTTER, .125 X 2.00, SST	3605207	1
18	PLUG - 1 5/16-12 SAE ORB, HEX SOC	3501575	3
19	PLUG - PIPE, 0.125, SST SOC HD	1080533	1
20	PLUG - PIPE, 0.250, SST SOC HD	1080535	5
21	PLUG - PIPE, 0.750 SST SQ HD	1080543	1
22	PLUG - PIPE, 0.750, SST SOC HD	1080551	3
23	PUMP CASING - ZS	2056400	1
24	SCREEN STRAINER	1122400	1
25	SEAL RING - ZS	3407500	2
26	SHAFT - IMPELLER, ZS	5022400	1
27	SLINGER - WATER, ZS, 1.894 ID	3203210	1
28	STRAINER - FITTING	1122300	1
29	STUD - 0.500-13 X 2.000, GR5	3606402	30
30	BEARING - BALL, 6311.C3	1725900	1
31	CAP - BEARING, IMPELLER, ZSE	2313303	1
32	CAP - BRG, INPUT, REAR, ZSE	2314701	1
33	CAP - BRG, INPUT, ZSE 2 GEAR	2314501	1
34	COMP FLANGE - 1550	4822510	1
35	COVER - OIL SUMP, ZSE 2 GEAR	2509200	1
36	DIPSTICK - -10 MORB PORT	4229104	1
37	FILTER - LUBE PUMP, 100 MESH	1124301	1
38	FTG - .38 JIC FE X .38 JIC MALE X 90	3501596	2
39	FTG - .38 JICM X 9/16-18, SAE ORB	3501567	1
40	FTG - .38 JICM X 9/16-18, SAE ORB	3501576	1
41	FTG - BRANCH TEE ADJUSTABLE, .38	3501609	1
42	FTG-88JICM RIGX.75MORB SVL 90	3501639	1
43	FTG-.88MORB RIGIDX1/8NPT FEMAL	3501634	1
44	GEAR - DRIVE, 51T, 6DP, RH, PTO	2719305	1
45	GEAR - PINION, 6 DP, LH, 29 T	2720410	1
46	GEARCASE - 2 GEAR ZSE	1806300	1
47	HHCS - .625-11 x 8.00, GR5	5400108	3
48	HHCS - FLANGED, .313-18 X 1.25	5402844	4
49	HHCS - FLANGED, .375-16 X 1.25	5402856	8
50	HHCS - FLANGED, .375-16 X 1.50	5402860	4
51	IMPELLER - ZS, L.H.	2908600	1
52	KEY - SQ., 0.38 X 3.00	3602407	1
53	KEY - SQ., 0.50 X 3.00	3602456	1
54	KIT-MOUNTING, ZSF SUCTION HEAD	KM02102	1
55	KIT-MOUNTING, ZSP GEAR CASE	KM02103	1
56	METAL TACK, 3/16 HEAD, .025 L	5402873	2
57	NUT - FLANGE, 1.2500-12 UNJF-3B	4822300	1
58	O-RING - 0.75 x 0.94 x 0.09	3601138	1
59	O-RING - 3.88 x 4.12 x .12	3601252	1
60	O-RING - 4.12 x 4.38 x 0.12	3601217	1
61	O-RING - 9.50 x 9.25 x 0.12	3601269_FORMED1	1
62	OIL SEAL - 2.750 ID X 3.505 OD	3600511	1
63	PIN - DOWEL, .375 X 0.625, GR8	3605410	2
64	PIN - DOWEL, 0.156 x 0.50, GR8	3605407	1
65	PLATE - SERIAL NO., .COM	1963109	1
66	PLUG - 3/4-16 SAE ORB, HEX SOC	3501573	3
67	PLUG - 7/16-20 SAE ORB, HEX SOC	3501629	2
68	PLUG - 7/8-14 SAE ORB, HEX SOC	3501632	3
69	PLUG - 9/16-18 SAE ORB, HEX SOC	3501578	1
70	PLUG - MAGNETIC, 3/4-16UNF	1080545	1
71	PLUG - PIPE, 0.125, W/.125 THRU	1080553	3
72	PRIMER - BELT DRV, 24V, ENG	AP02400	1
73	PUMP - HYD, INTERNAL GEAR, LUBE	4821020	1
74	SHAFT - INPUT, 2 GR ZSP	5023700	1
75	SLEEVE - MEGATRANS, OIL PUMP	1887400	1
76	SPACER - 2.17 X 2.62 X .513	3309301	1
77	SPACER - 2.17 x 2.63 x .611	3305202	1
78	SPRING CARTRIDGE - OIL PUMP	4821100	1
79	TUBE - LUBE PUMP DISCH, ZSE	4434153	1
80	TUBE - LUBE PUMP DISCH, ZSE	4434154	1
81	TUBE - LUBE PUMP DISCH, ZSE	4434155	1
82	TUBE - LUBE PUMP SUCTION, ZSE	4432160	1
83	VENT - GEARCASE, 1/8 NPT MALE	4401801	1
84	WASHER - FLAT, .641 X 1.303 X .160	3603825	3
85	O-RING - .644 x .818 x 0.087	3601900	1

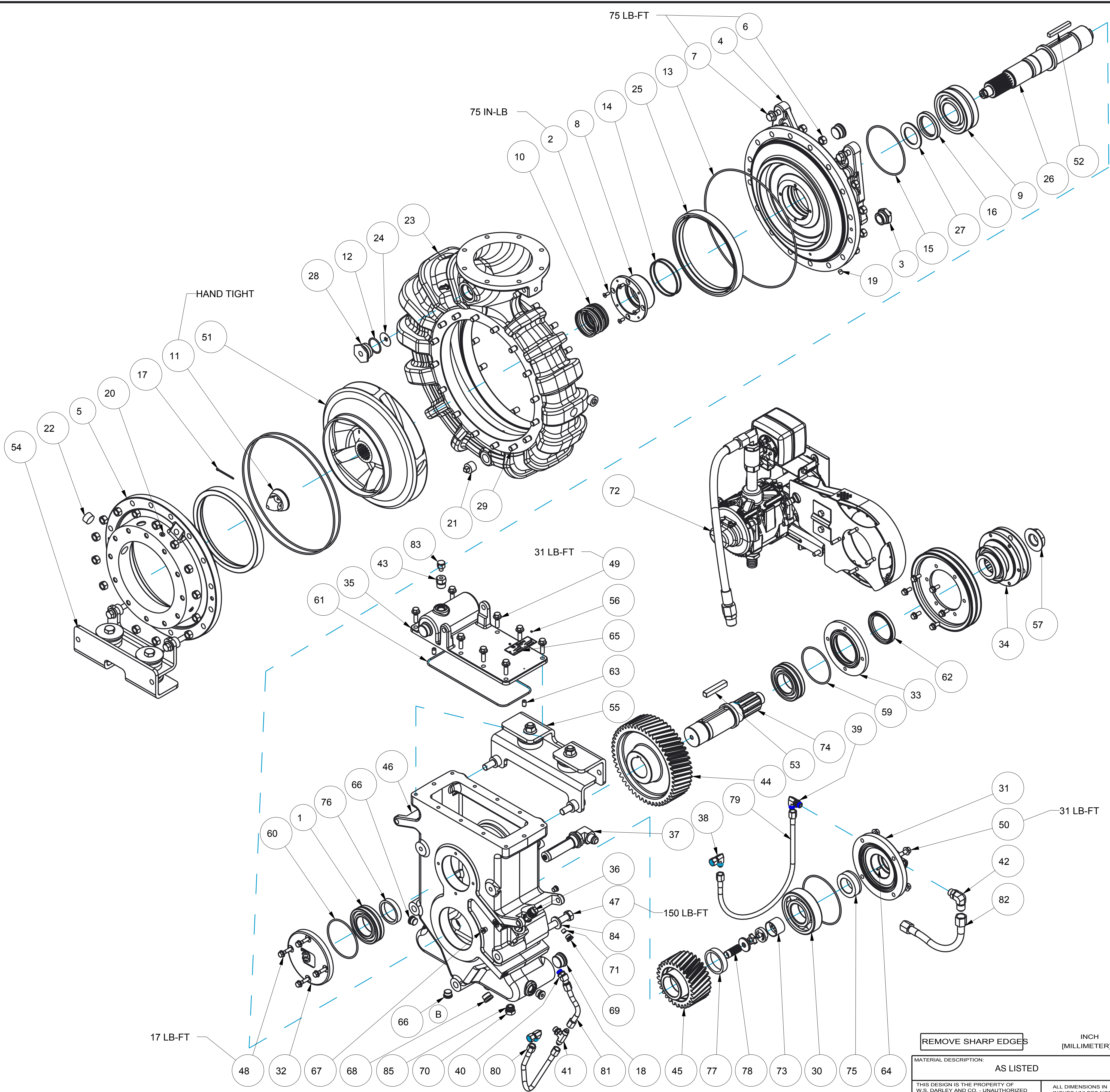

REVISIONS				
LTR	DESCRIPTION	DATE	CHG NO.	APPRD
A	3601900 WAS 3601138	30JUL2015	11080	SMS
B	ADDED 1 - 3501573	15JAN2016	11275	WAH

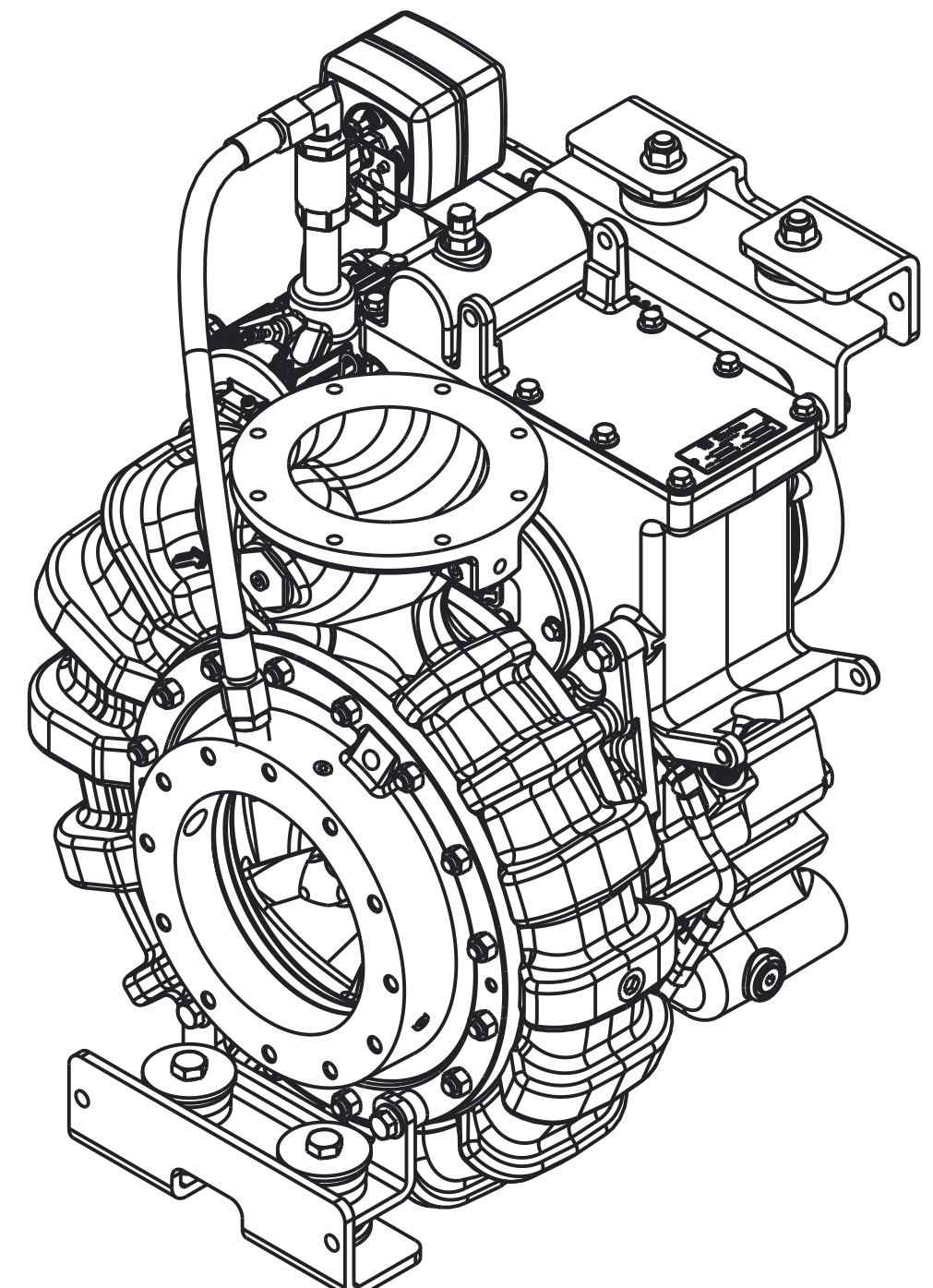

B

A

REMOVE SHARP EDGES		INCH (MILLIMETER)	OLD PART NO.	TOLERANCE EXCEPT AS NOTED	W.S. Darley & Co. ITASCA, IL - CHIPPEWA FALLS, WI
MATERIAL DESCRIPTION: AS LISTED	MATERIAL NO.	PATTERN NO.	00 ±.03 2000 ±.010 ANGLES ±.1°	DWG - ZSP, INPUT ABOVE CROSS SECTION	DATE 10-Jul-14
THIS DESIGN IS THE PROPERTY OF W.S. DARLEY AND CO. - UNAUTHORIZED REPRODUCTION IS PROHIBITED	ALL DIMENSIONS IN INCHES UNLESS NOTED	DO NOT SCALE PRINT	DRY SMS CHKD WAH TRCD	SCALE 3/16	DZC0019

MODEL NAME: DZC0019 MDL CREATED: 10JUL2014 SHEET: 2/2 D



NO.	DESCRIPTION	PART NO.	QTY.
1	BEARING - 22211E C3	1726300	2
2	FHMS - .250-20 x 0.63, SS	5402402	4
3	FTG - 1.00 ORB MALE X -06 JIC MALE	3501574	2
4	HEAD - INBOARD, ZS	2812600	1
5	HEAD - SUCTION, ZS	2812700	1
6	HEX NUT - .500-13, GR 2	5403005	30
7	HHCS - FLANGED, .500-13 X 1.75	5402853	2
8	HOUSING - MECHANICAL SEAL, ZS	1846200	1
9	BEARING - 22311E C3	1726100	1
10	MECHANICAL SEAL - 2.00", ZS	1846300	1
11	NUT - IMPELLER, CONE, ZS	5403477	1
12	O-RING - 1.47 x 1.71 x 0.09	3601401	1
13	O-RING - 13.00 x 12.75 x 0.12	3601272	3
14	O-RING - 3.75 x 3.94 X 0.09	3601133	2
15	O-RING - 5.25 x 5.50 x 0.12	3601232	2
16	OIL SEAL - 2.125 ID X 3.000 OD	3600571	1
17	PIN - COTTER, .125 x 2.00, SST	3605207	1
18	PLUG - 1 5/16-12 SAE ORB, HEX SOC	3501575	3
19	PLUG - PIPE, 0.125, SST SOC HD	1080533	1
20	PLUG - PIPE, 0.250, SST SOC HD	1080535	5
21	PLUG - PIPE, 0.750 SST SQ HD	1080543	1
22	PLUG - PIPE, 0.750, SST SOC HD	1080551	3
23	PUMP CASING - ZS	2056400	1
24	SCREEN STRAINER	1122400	1
25	SEAL RING - ZS	3407500	2
26	SHAFT - IMPELLER, ZS	5022400	1
27	SLINGER - WATER, ZS, 1.894 ID	3203210	1
28	STRAINER - FITTING	1122300	1
29	STUD - 0.500-13 X 2.000, GR5	3606402	30
30	BEARING - BALL, 6311.C3	1725900	1
31	CAP - BEARING, IMPELLER, ZSE	2313303	1
32	CAP - BRG, INPUT, REAR, ZSE	2314701	1
33	CAP - BRG, INPUT, ZSE 2 GEAR	2314501	1
34	COMP FLANGE - 1550	4822510	1
35	COVER - OIL SUMP, ZSE 2 GEAR	2509200	1
36	DIPSTICK - -10 MORB PORT	4229105	1
37	FILTER - LUBE PUMP, 100 MESH	1124301	1
38	FTG - .38 JIC FE X .38 JIC MALE X 90	3501596	2
39	FTG - .38 JICM X 9/16-18, SAE ORB	3501567	1
40	FTG - .38 JICM X 9/16-18, SAE ORB	3501576	1
41	FTG - BRANCH TEE ADJUSTABLE, .38	3501609	1
42	FTG - .62 JICM X 3/4-16 SAE ORB	3501569	1
43	FTG-.88MORB RIGIDX1/8NPT FEMAL	3501634	1
44	GEAR - DRIVE, 51T, 6DP, RH, PTO	2719305	1
45	GEAR - PINION, 6 DP, LH, 29 T	2720410	1
46	GEARCASE - 2 GEAR ZSE	1806300	1
47	HHCS - .625-11 x 8.00, GR5	5400108	3
48	HHCS - FLANGED, .313-18 X 1.25	5402844	4
49	HHCS - FLANGED, .375-16 X 1.25	5402856	8
50	HHCS - FLANGED, .375-16 X 1.50	5402860	4
51	IMPELLER - ZS, L.H.	2908600	1
52	KEY - SQ., 0.38 X 3.00	3602407	1
53	KEY - SQ., 0.50 x 3.00	3602456	1
54	KIT-MOUNTING, ZSF SUCTION HEAD	KM02102	1
55	KIT-MOUNTING, ZSP GEAR CASE	KM02103	1
56	METAL TACK, 3/16 HEAD, .025 L	5402873	2
57	NUT - FLANGE, 1.2500-12 UNJF-3B	4822300	1
58	O-RING - 0.75 x 0.94 x 0.09	3601138	1
59	O-RING - 3.88 x 4.12 x .12	3601252	1
60	O-RING - 4.12 x 4.38 x 0.12	3601217	1
61	O-RING - 9.50 x 9.25 x 0.12	3601269_FORMED1	1
62	OIL SEAL - 2.750 ID X 3.505 OD	3600511	1
63	PIN - DOWEL, .375 X 0.625, GR8	3605410	2
64	PIN - DOWEL, 0.156 x 0.50, GR8	3605407	1
65	PLATE - SERIAL NO., .COM	1963109	1
66	PLUG - 3/4-16 SAE ORB, HEX SOC	3501573	3
67	PLUG - 7/16-20 SAE ORB, HEX SOC	3501629	2
68	PLUG - 7/8-14 SAE ORB, HEX SOC	3501632	3
69	PLUG - 9/16-18 SAE ORB, HEX SOC	3501578	1
70	PLUG - MAGNETIC, 3/4-16UNF	1080545	1
71	PLUG - PIPE, 0.125, W/.125 THRU	1080553	3
72	PRIMER - BELT DRV, 24V, ENG	AP02400_STANDAR	1
73	PUMP - HYD, INTERNAL GEAR, LUBE	4821020	1
74	SHAFT - INPUT, 2 GR ZSP	5023700	1
75	SLEEVE - MEGATRANS, OIL PUMP	1887400	1
76	SPACER - 2.17 X 2.62 X .513	3309301	1
77	SPACER - 2.17 x 2.63 x .611	3305202	1
78	SPRING CARTRIDGE - OIL PUMP	4821100	1
79	TUBE - LUBE PUMP DISCH, ZSE	4434153	1
80	TUBE - LUBE PUMP DISCH, ZSE	4434154	1
81	TUBE - LUBE PUMP DISCH, ZSE	4434155	1
82	TUBE - LUBE PUMP SUCTION, ZSE	4432161_DZD00201	1
83	VENT - GEARCASE, 1/8 NPT MALE	4401801	1
84	WASHER - FLAT, .641 X 1.303 X .160	3603825	3
85	O-RING - .644 x .818 x 0.087	3601900	1

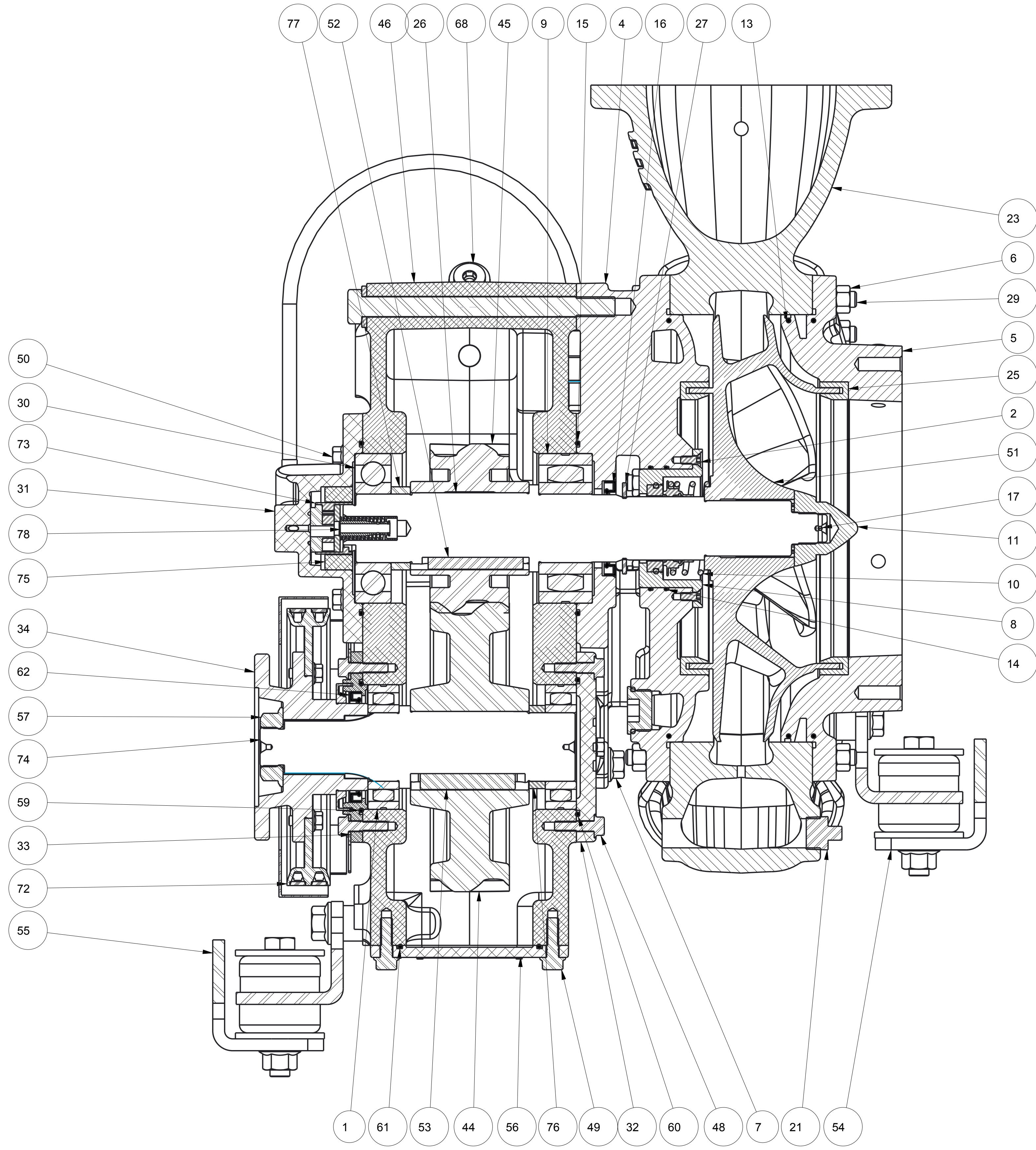

SECTION A-A

REVISIONS				
LTR	DESCRIPTION	DATE	CHG NO.	APPRD
A	3601900 WAS 3601138	30JUL2015	11080	SMS
B	ADDED 1 - 3501573	15JAN2016	11275	WAH

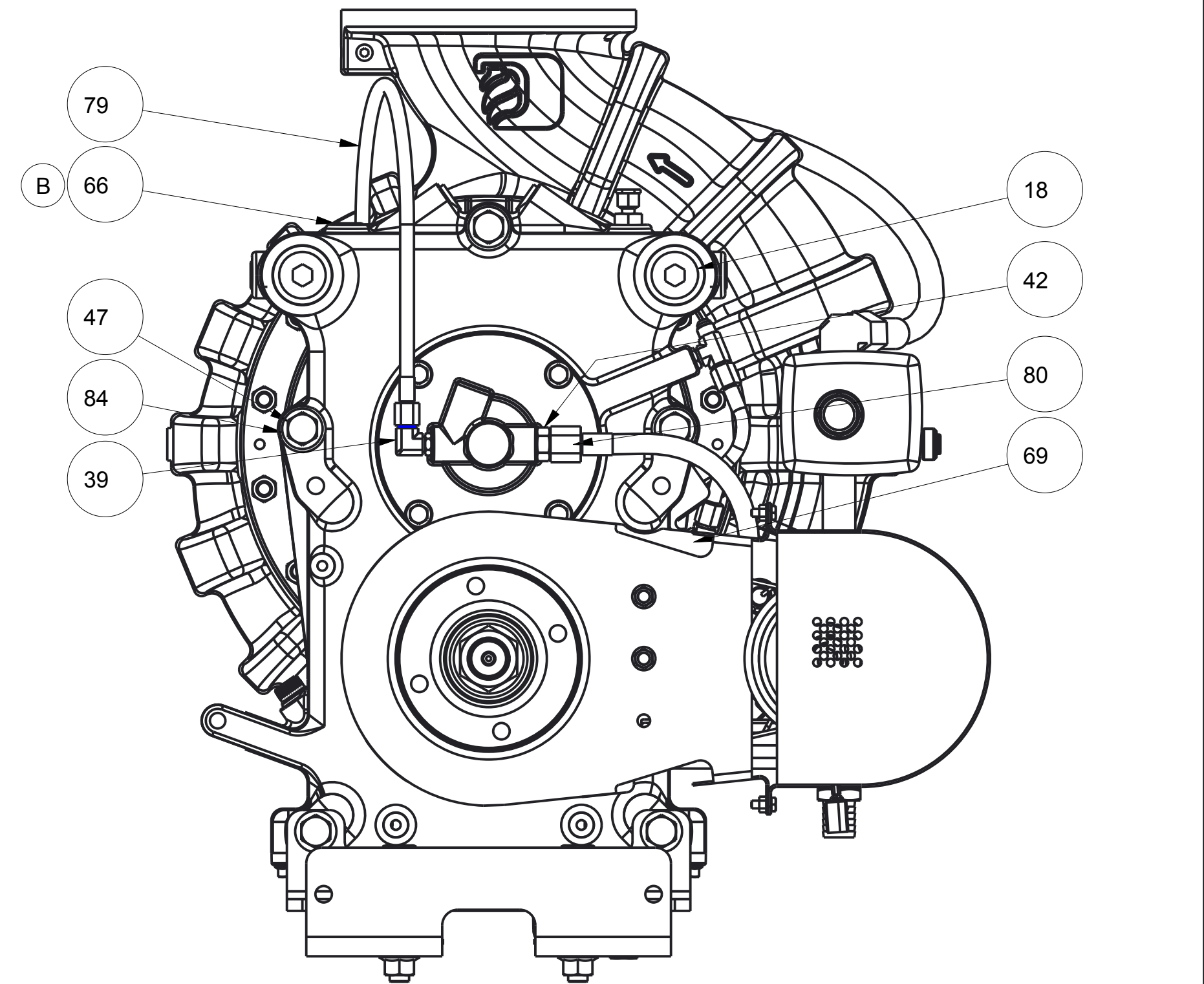

SCALE 1/4

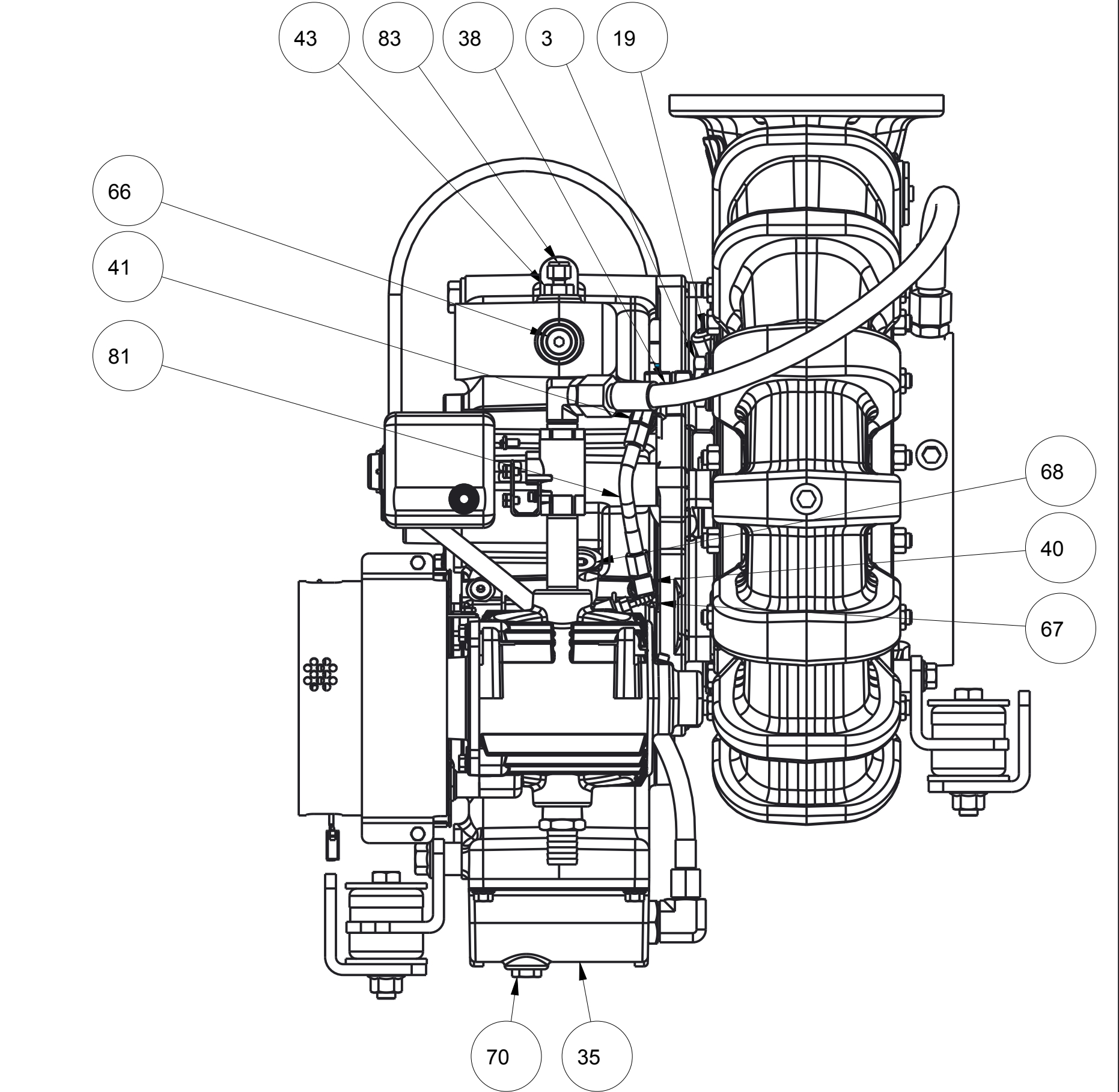

MODEL NAME	MDL CREATED	SHEET
DZC0020	10JUL2014	1/2 D

REMOVE SHARP EDGES	INCH (MILLIMETER)	OLD PART NO.	TOLERANCE EXCEPT AS NOTED 00 ±.03 2000 ±.010 ANGLES ±.1°	W.S. Darley & Co. ITASCA, IL - CHIPPEWA FALLS, WI
MATERIAL DESCRIPTION: AS LISTED	MATERIAL NO.	PATTERN NO.	DRY SMS 2000 ±.010 TRCD	DWG - ZSP, INPUT STANDARD CROSS SECTION
THIS DESIGN IS THE PROPERTY OF W.S. DARLEY AND CO. - UNAUTHORIZED REPRODUCTION IS PROHIBITED	ALL DIMENSIONS IN INCHES UNLESS NOTED	DO NOT SCALE PRINT	DATE 09-Jul-14 SCALE 1/2	DZC0020



NO.	DESCRIPTION	PART NO.	QTY.
1	BEARING - 22211E C3	1726300	2
2	FHMS - .250-20 x 0.63, SS	5402402	4
3	FTG - 1.00 ORB MALE X -06 JIC MALE	3501574	2
4	HEAD - INBOARD, ZS	2812600	1
5	HEAD - SUCTION, ZS	2812700	1
6	HEX NUT - .500-13, GR 2	5403005	30
7	HHCS - FLANGED, .500-13 X 1.75	5402853	2
8	HOUSING - MECHANICAL SEAL, ZS	1846200	1
9	BEARING - 22311E C3	1726100	1
10	MECHANICAL SEAL - 2.00", ZS	1846300	1
11	NUT - IMPELLER, CONE, ZS	5403477	1
12	O-RING - 1.47 x 1.71 x 0.09	3601401	1
13	O-RING - 13.00 x 12.75 x 0.12	3601272	3
14	O-RING - 3.75 x 3.94 X 0.09	3601133	2
15	O-RING - 5.25 x 5.50 x 0.12	3601232	2
16	OIL SEAL - 2.125 ID X 3.000 OD	3600571	1
17	PIN - COTTER, .125 x 2.00, SST	3605207	1
18	PLUG - 1 5/16-12 SAE ORB, HEX SOC	3501575	3
19	PLUG - PIPE, 0.125, SST SOC HD	1080533	1
20	PLUG - PIPE, 0.250, SST SOC HD	1080535	5
21	PLUG - PIPE, 0.750 SST SQ HD	1080543	1
22	PLUG - PIPE, 0.750, SST SOC HD	1080551	3
23	PUMP CASING - ZS	2056400	1
24	SCREEN STRAINER	1122400	1
25	SEAL RING - ZS	3407500	2
26	SHAFT - IMPELLER, ZS	5022400	1
27	SLINGER - WATER, ZS, 1.894 ID	3203210	1
28	STRAINER - FITTING	1122300	1
29	STUD - 0.500-13 X 2.000, GR5	3606402	30
30	BEARING - BALL, 6311.C3	1725900	1
31	CAP - BEARING, IMPELLER, ZSE	2313303	1
32	CAP - BRG, INPUT, REAR, ZSE	2314701	1
33	CAP - BRG, INPUT, ZSE 2 GEAR	2314501	1
34	COMP FLANGE - 1550	4822510	1
35	COVER - OIL SUMP, ZSE 2 GEAR	2509200	1
36	DIPSTICK - -10 MORB PORT	4229105	1
37	FILTER - LUBE PUMP, 100 MESH	1124301	1
38	FTG - .38 JIC FE X .38 JIC MALE X 90	3501596	2
39	FTG - .38 JICM X 9/16-18, SAE ORB	3501567	1
40	FTG - .38 JICM X 9/16-18, SAE ORB	3501576	1
41	FTG - BRANCH TEE ADJUSTABLE, .38	3501609	1
42	FTG - .62 JICM X 3/4-16 SAE ORB	3501569	1
43	FTG-.88MORB RIGIDX1/8NPT FEMAL	3501634	1
44	GEAR - DRIVE, 51T, 6DP, RH, PTO	2719305	1
45	GEAR - PINION, 6 DP, LH, 29 T	2720410	1
46	GEARCASE - 2 GEAR ZSE	1806300	1
47	HHCS - .625-11 x 8.00, GR5	5400108	3
48	HHCS - FLANGED, .313-18 X 1.25	5402844	4
49	HHCS - FLANGED, .375-16 X 1.25	5402856	8
50	HHCS - FLANGED, .375-16 X 1.50	5402860	4
51	IMPELLER - ZS, L.H.	2908600	1
52	KEY - SQ., 0.38 X 3.00	3602407	1
53	KEY - SQ., 0.50 x 3.00	3602456	1
54	KIT-MOUNTING, ZSF SUCTION HEAD	KM02102	1
55	KIT-MOUNTING, ZSP GEAR CASE	KM02103	1
56	METAL TACK, 3/16 HEAD, .025 L	5402873	2
57	NUT - FLANGE, 1.2500-12 UNJF-3B	4822300	1
58	O-RING - 0.75 x 0.94 x 0.09	3601138	1
59	O-RING - 3.88 x 4.12 x .12	3601252	1
60	O-RING - 4.12 x 4.38 x 0.12	3601217	1
61	O-RING - 9.50 x 9.25 x 0.12	3601269_FORMED1	1
62	OIL SEAL - 2.750 ID X 3.505 OD	3600511	1
63	PIN - DOWEL, .375 X 0.625, GR8	3605410	2
64	PIN - DOWEL, 0.156 x 0.50, GR8	3605407	1
65	PLATE - SERIAL NO., .COM	1963109	1
66	PLUG - 3/4-16 SAE ORB, HEX SOC	3501573	3
67	PLUG - 7/16-20 SAE ORB, HEX SOC	3501629	2
68	PLUG - 7/8-14 SAE ORB, HEX SOC	3501632	3
69	PLUG - 9/16-18 SAE ORB, HEX SOC	3501578	1
70	PLUG - MAGNETIC, 3/4-16UNF	1080545	1
71	PLUG - PIPE, 0.125, W/.125 THRU	1080553	3
72	PRIMER - BELT DRV, 24V, ENG	AP02400_STANDAR	1
73	PUMP - HYD, INTERNAL GEAR, LUBE	4821020	1
74	SHAFT - INPUT, 2 GR ZSP	5023700	1
75	SLEEVE - MEGATRANS, OIL PUMP	1887400	1
76	SPACER - 2.17 X 2.62 X .513	3309301	1
77	SPACER - 2.17 x 2.63 x .611	3305202	1
78	SPRING CARTRIDGE - OIL PUMP	4821100	1
79	TUBE - LUBE PUMP DISCH, ZSE	4434153	1
80	TUBE - LUBE PUMP DISCH, ZSE	4434154	1
81	TUBE - LUBE PUMP DISCH, ZSE	4434155	1
82	TUBE - LUBE PUMP SUCTION, ZSE	4432161_DZD00201	1
83	VENT - GEARCASE, 1/8 NPT MALE	4401801	1
84	WASHER - FLAT, .641 X 1.303 X .160	3603825	3
85	O-RING - .644 x .818 x 0.087	3601900	1

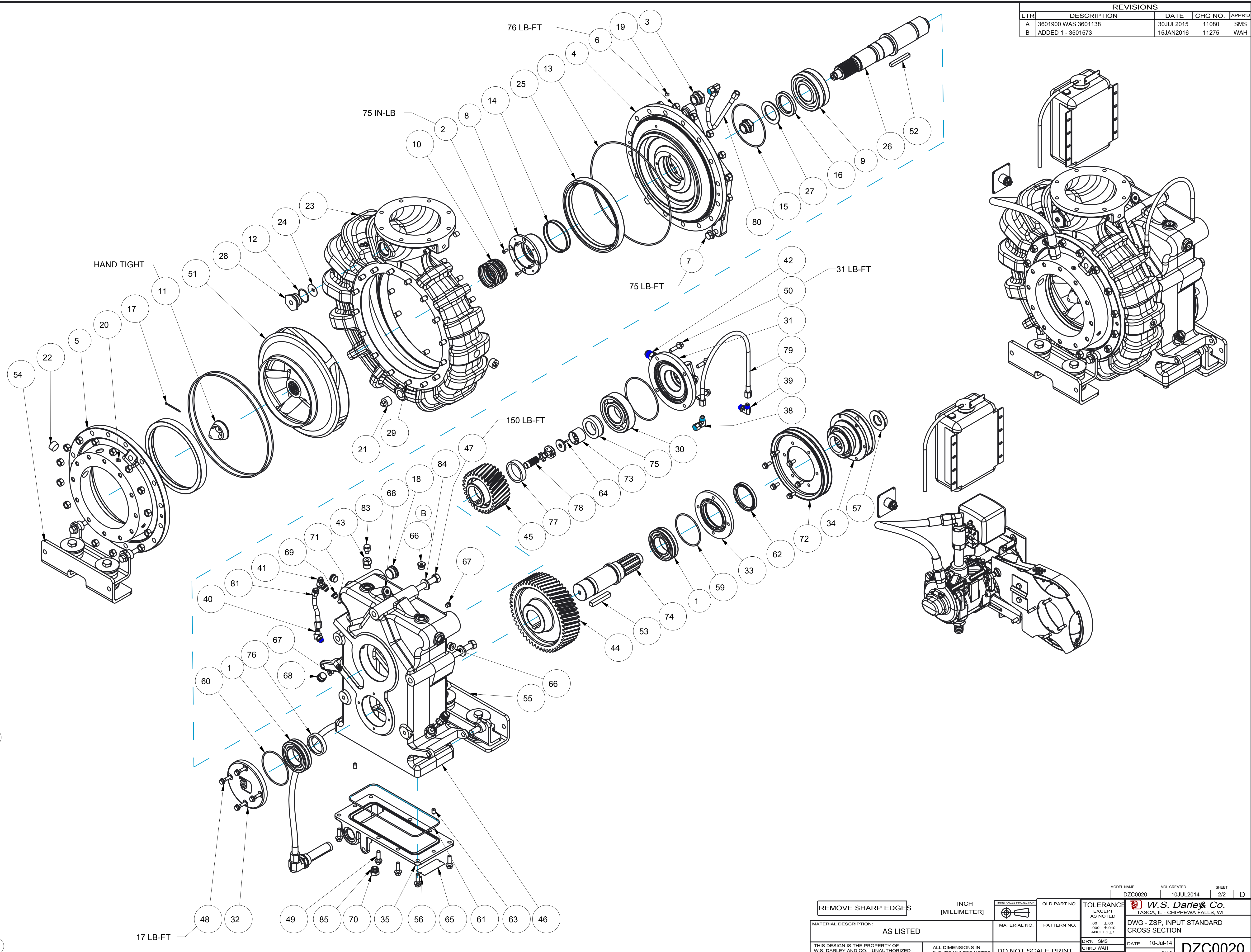

REVISIONS				
LTR	DESCRIPTION	DATE	CHG NO.	APPRD
A	3601900 WAS 3601138	30JUL2015	11080	SMS
B	ADDED 1 - 3501573	15JAN2016	11275	WAH

REMOVE SHARP EDGES		INCH (MILLIMETER)	OLD PART NO.	TOLERANCE EXCEPT AS NOTED 00 ±.03 2000 ±.010 ANGLES ±.1°	W.S. Darley & Co. ITASCA, IL - CHIPPEWA FALLS, WI
MATERIAL DESCRIPTION: AS LISTED		MATERIAL NO.	PATTERN NO.	DRY SMS CHKD WAH TRCD	DWG - ZSP, INPUT STANDARD CROSS SECTION
THIS DESIGN IS THE PROPERTY OF W.S. DARLEY AND CO. - UNAUTHORIZED REPRODUCTION IS PROHIBITED		DO NOT SCALE PRINT		DATE 10-Jul-14 SCALE 3/16	DZC0020

MODEL NAME: DZC0020 MDL CREATED: 10JUL2014 SHEET: 2/2



REVISIONS				
LTR	DESCRIPTION	DATE	CHG NO.	APPRD

OPTIONAL PUMP CASING POSITIONS  
DISCHARGE CENTERED TO SUCTION

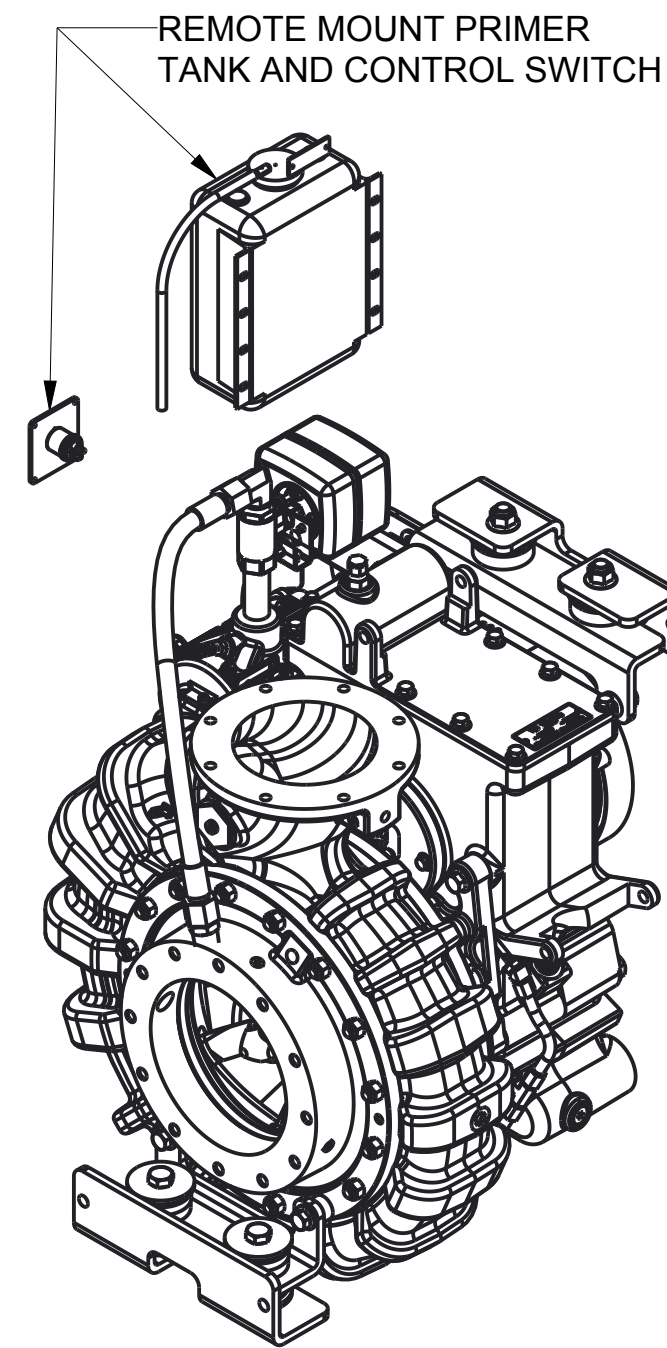

SCALE 1/8

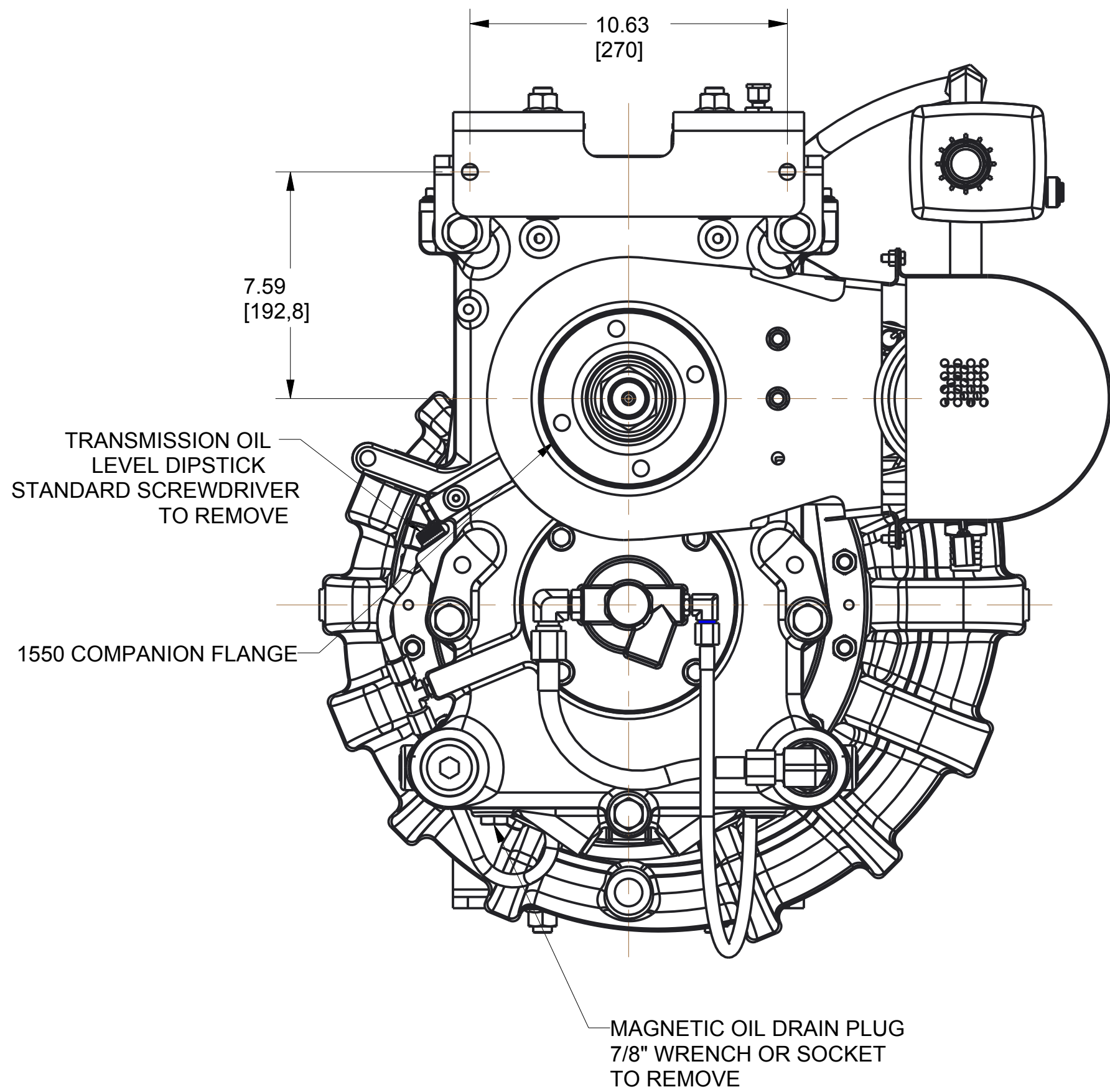
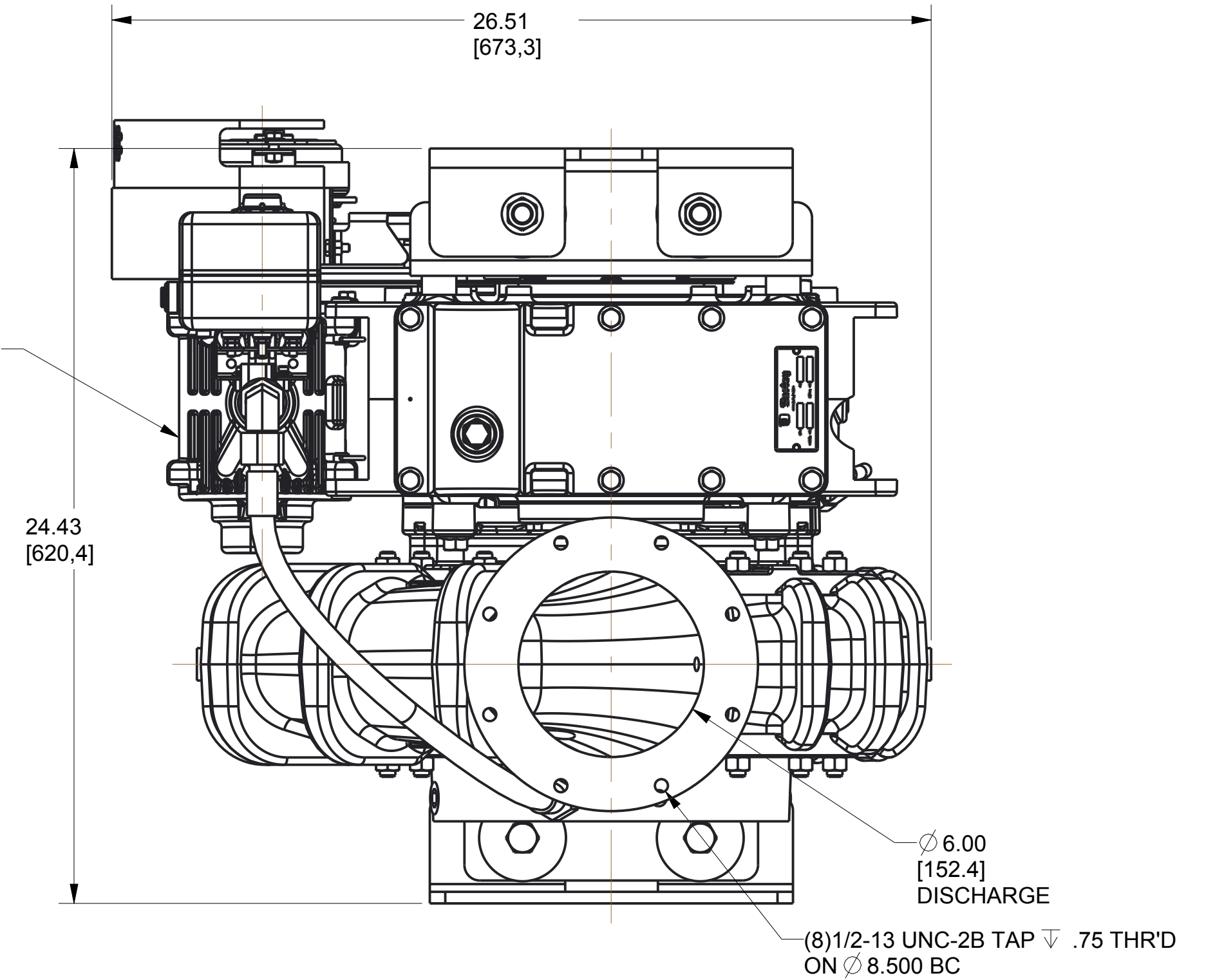
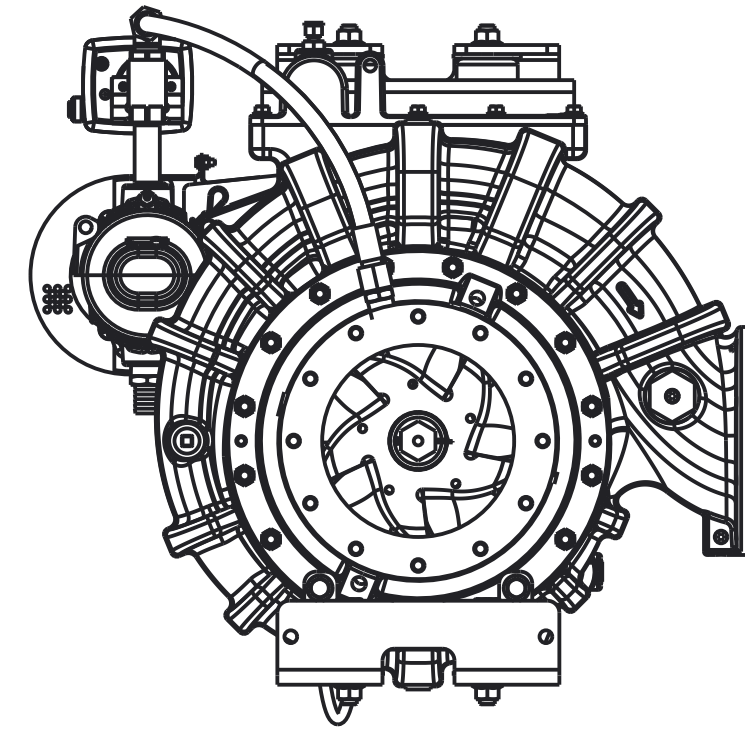
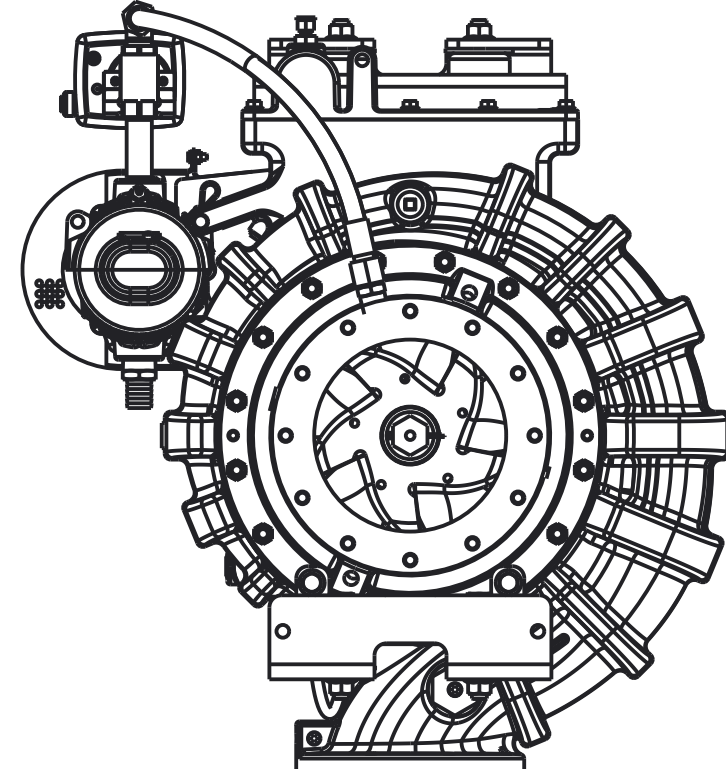
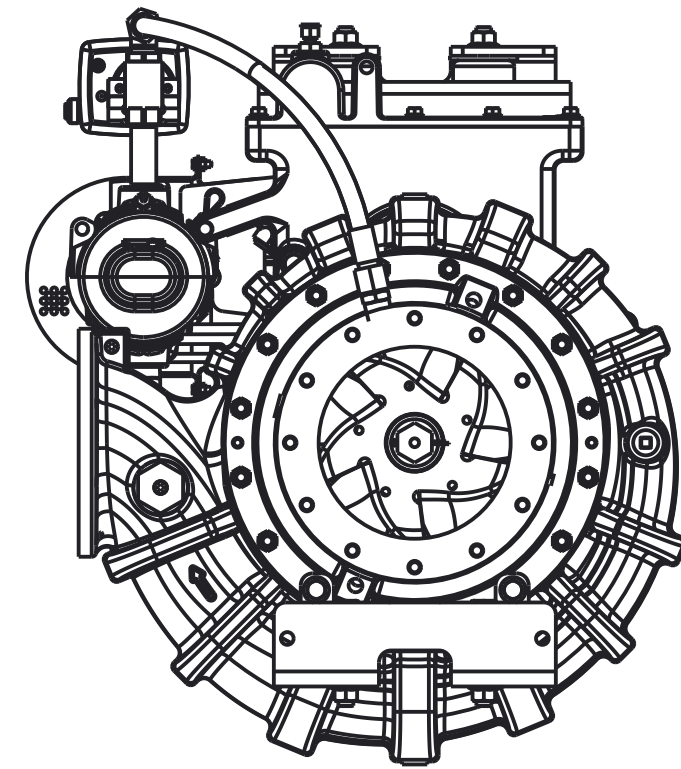

APPROXIMATE WEIGHT 690 LBS [312]

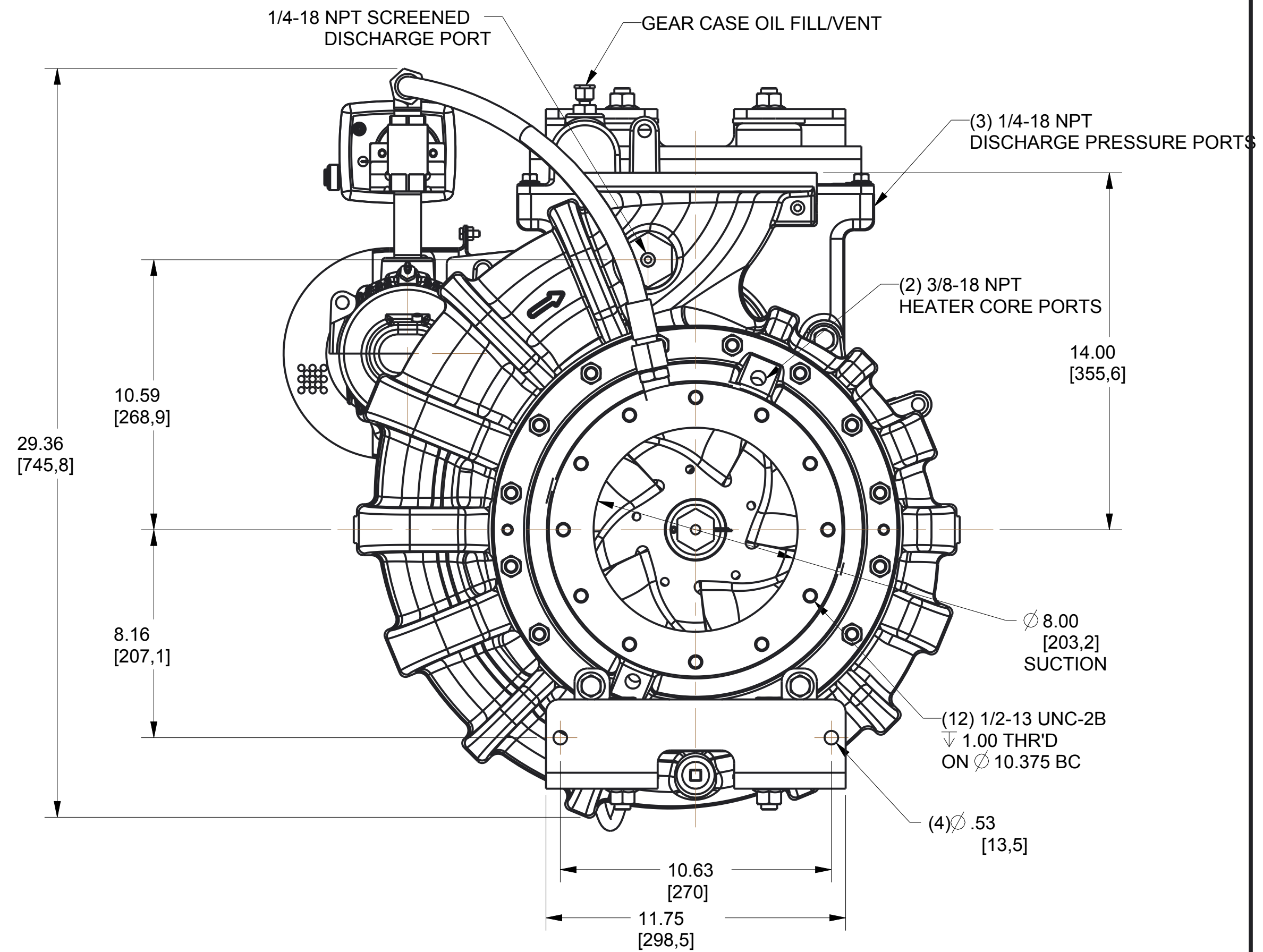
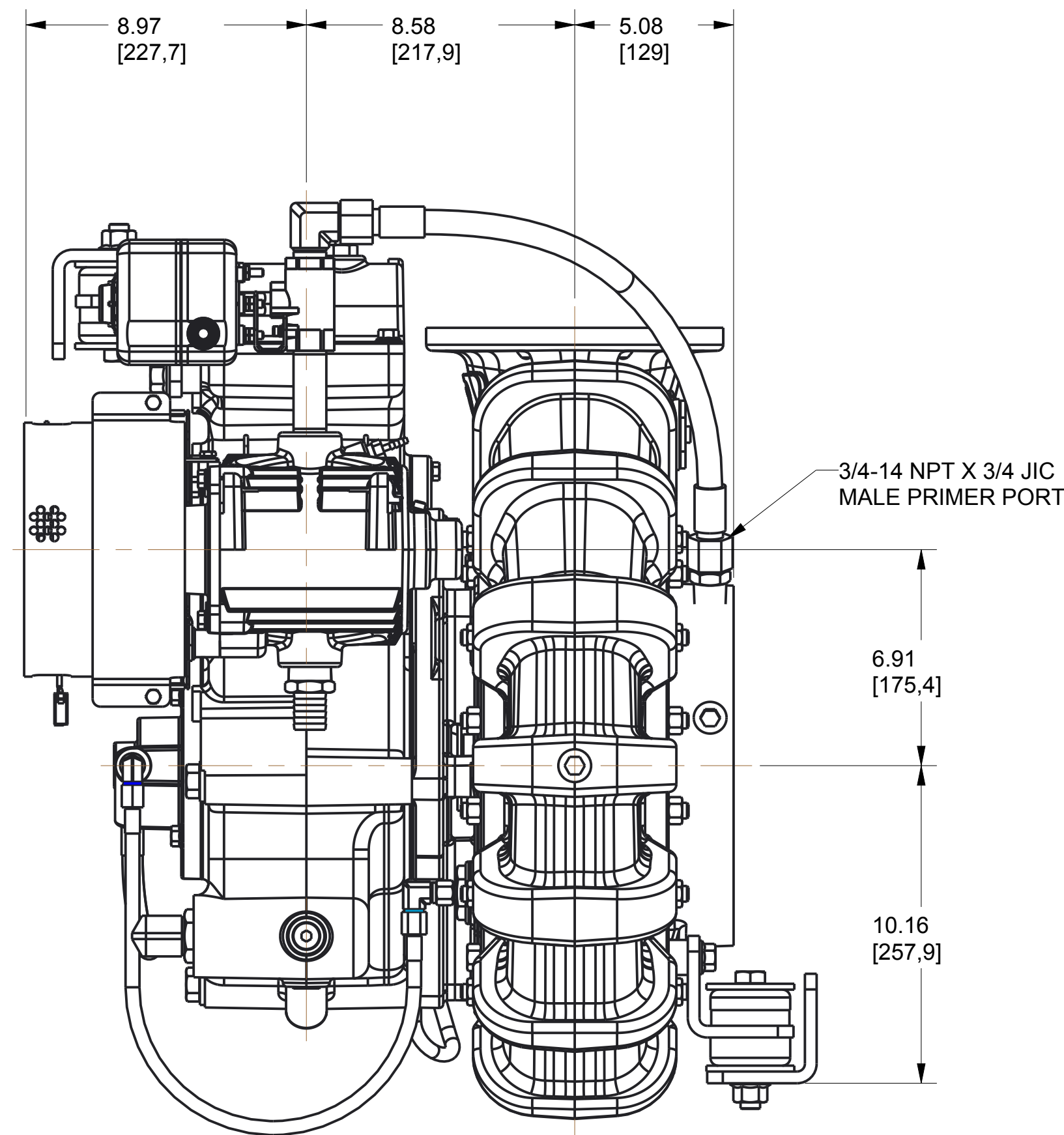

MODEL NAME: DZC0019  
MIX CREATED: 10JUL2014  
SHEET: 1/1

REMOVE SHARP EDGES	INCH [MILLIMETER]	OLD PART NO.	TOLERANCE EXCEPT AS NOTED 00 ±.03 2000 ±.010 ANGLES ±1°	W.S. Darley & Co. ITASCA, IL - CHIPPEWA FALLS, WI
MATERIAL DESCRIPTION: AS LISTED		MATERIAL NO.	PATTERN NO.	DWG - ZSP, INPUT ABOVE CROSS SECTION
THIS DESIGN IS THE PROPERTY OF W.S. DARLEY AND CO. - UNAUTHORIZED REPRODUCTION IS PROHIBITED	ALL DIMENSIONS IN INCHES UNLESS NOTED	DO NOT SCALE PRINT	DRN SMS CHKD TRCD	DATE 14-Jul-14 SCALE 1/4

DZD0034



REVISIONS				
LTR	DESCRIPTION	DATE	CHG NO.	APPRD

REMOTE MOUNT PRIMER AND TANK CONTROL SWITCH

OPTIONAL PUMP CASING POSITIONS  
DISCHARGE CENTERED TO SUCTION

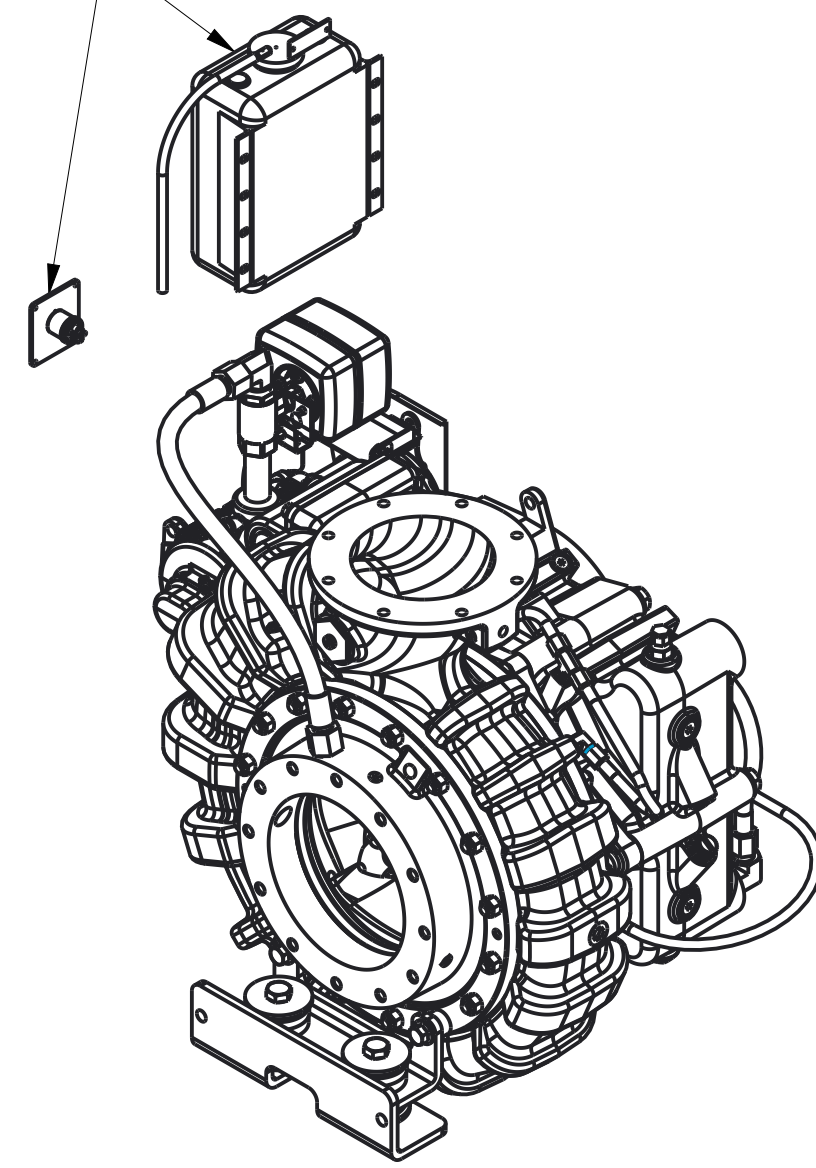

SCALE 1/8

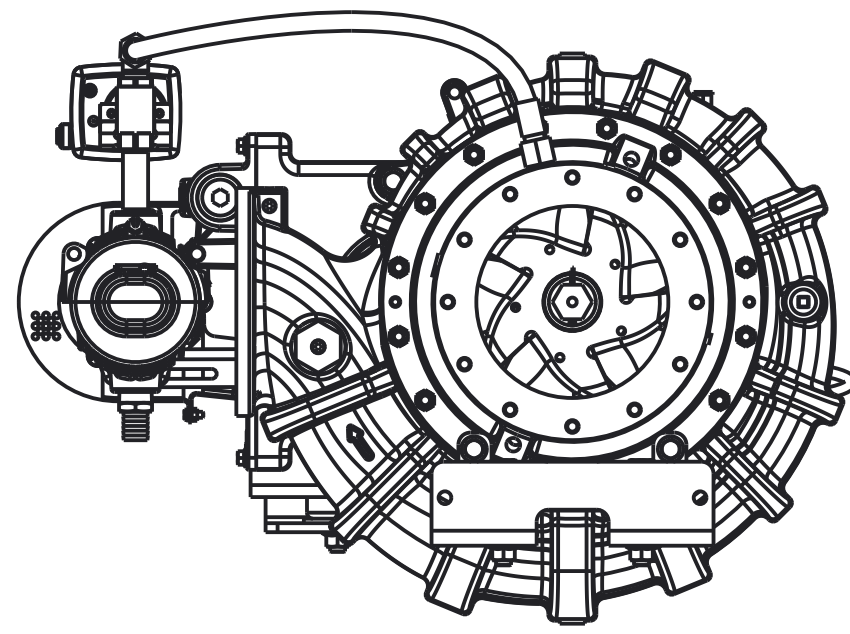

9 O'CLOCK DISCHARGE

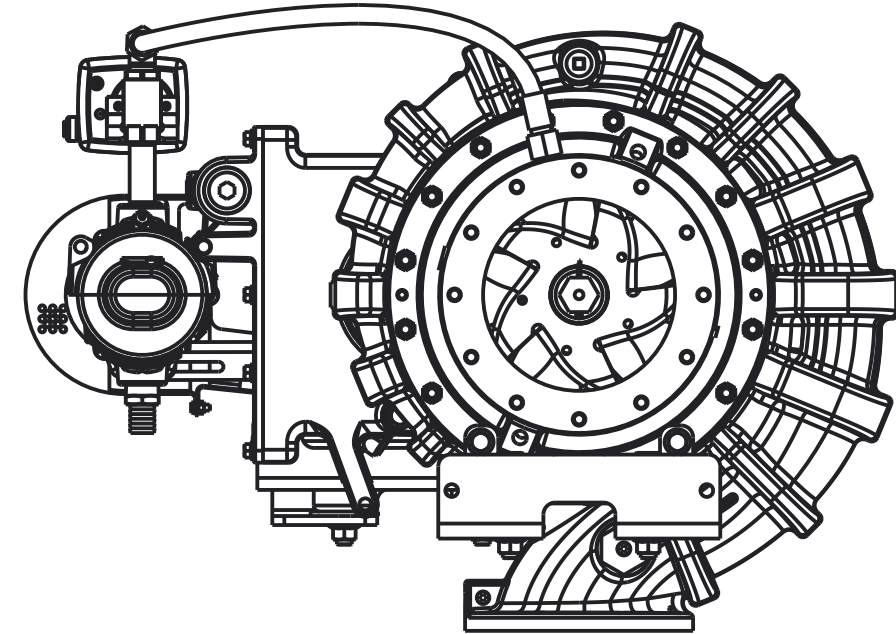

6 O'CLOCK DISCHARGE

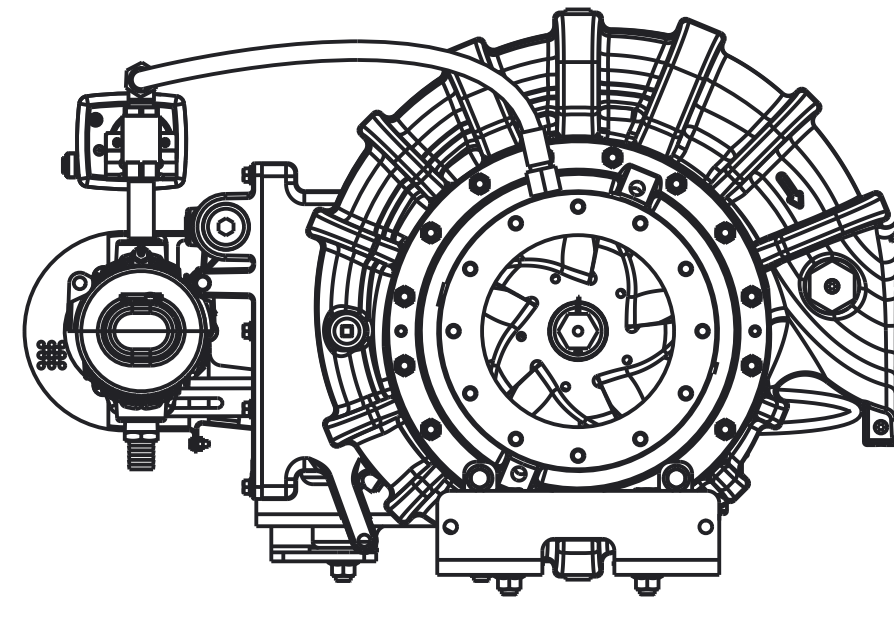

3 O'CLOCK DISCHARGE

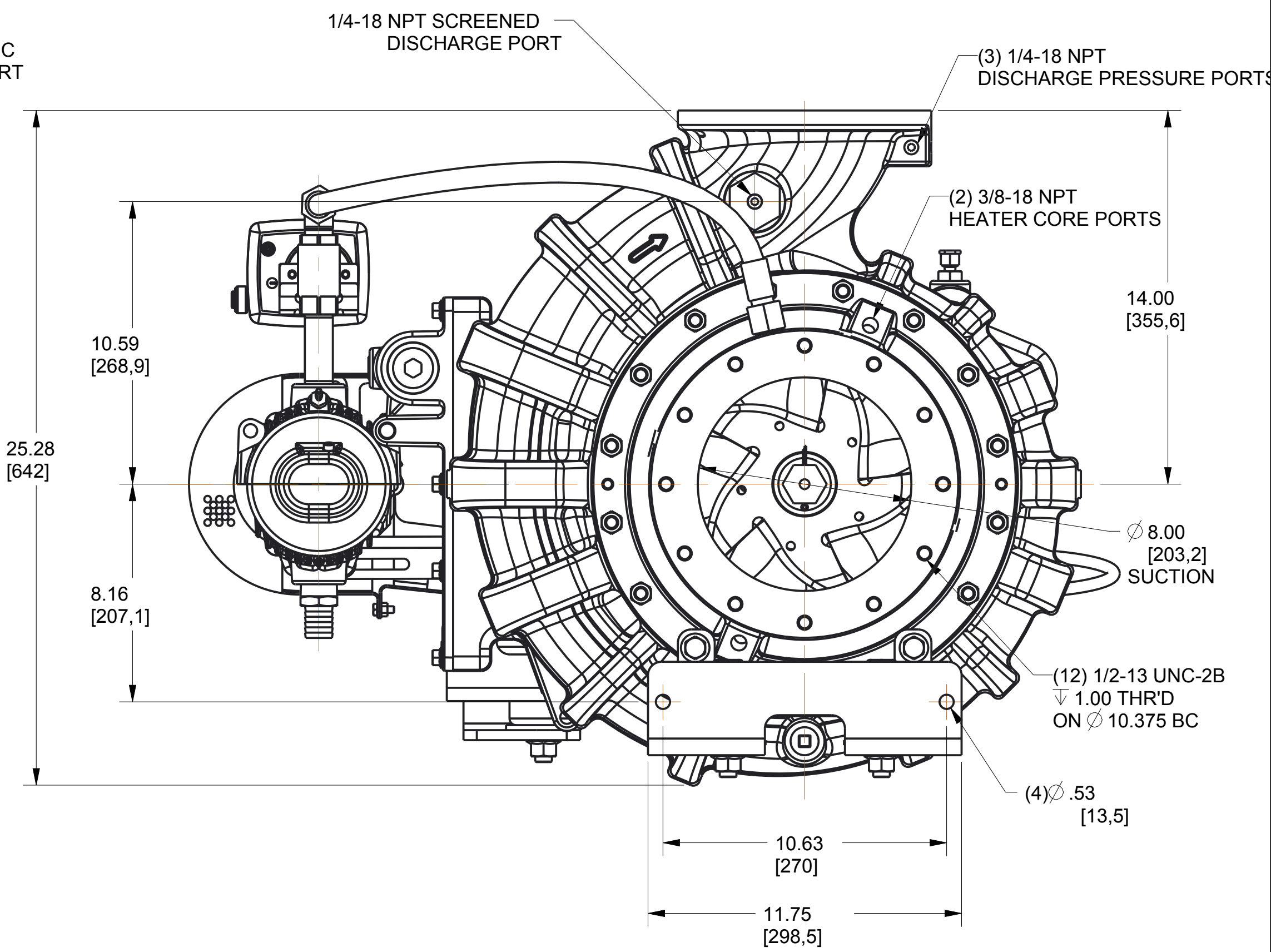
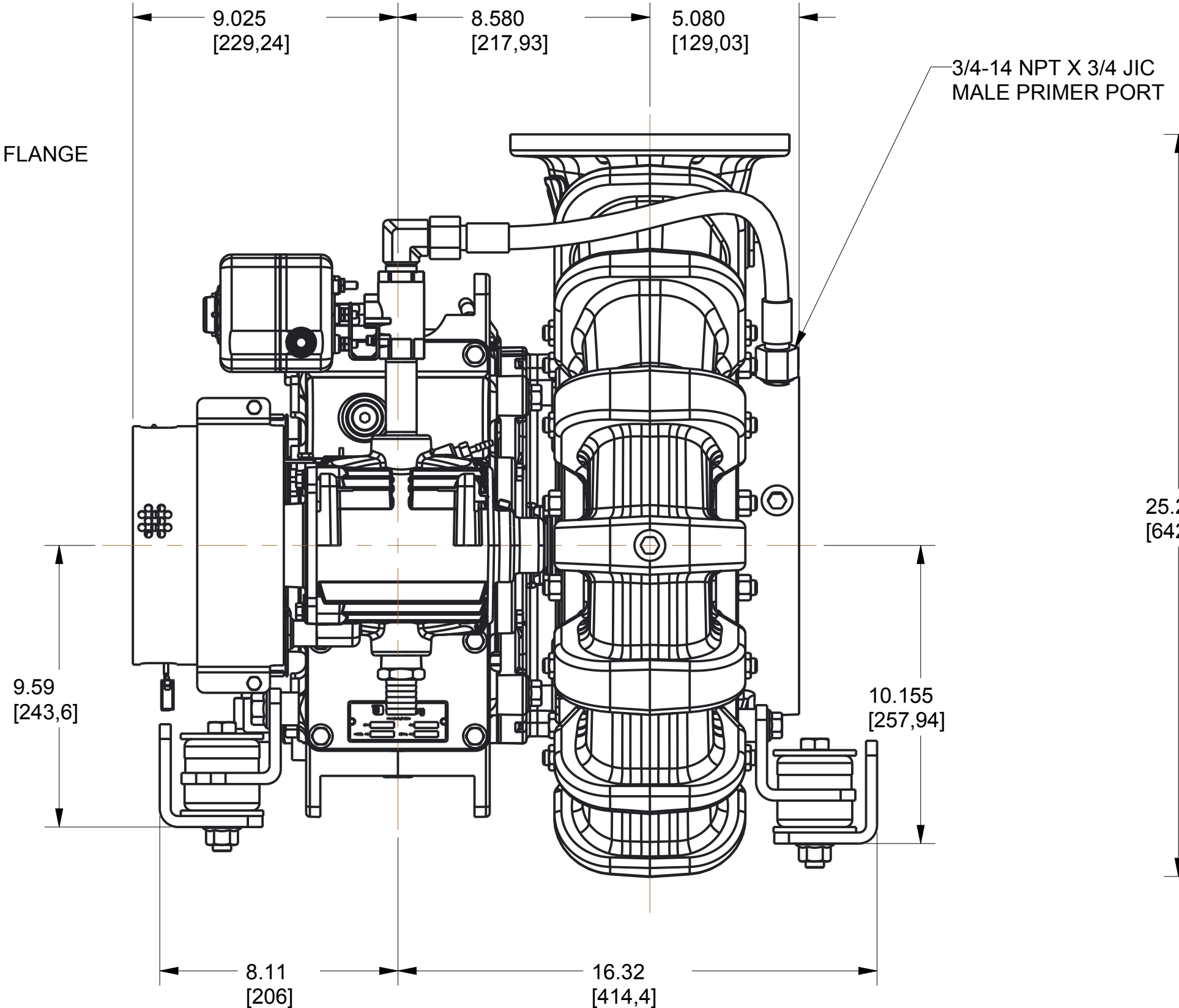
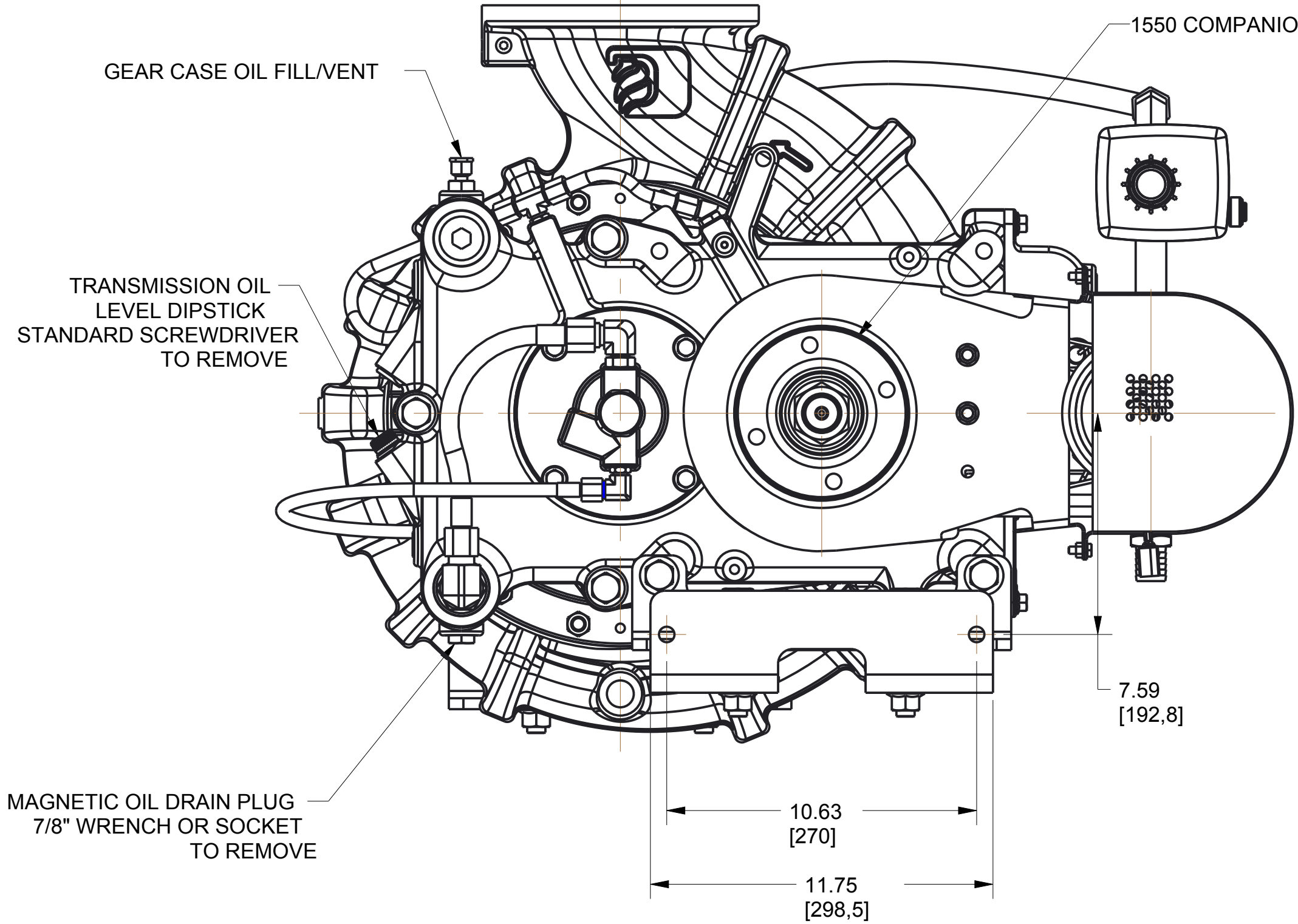
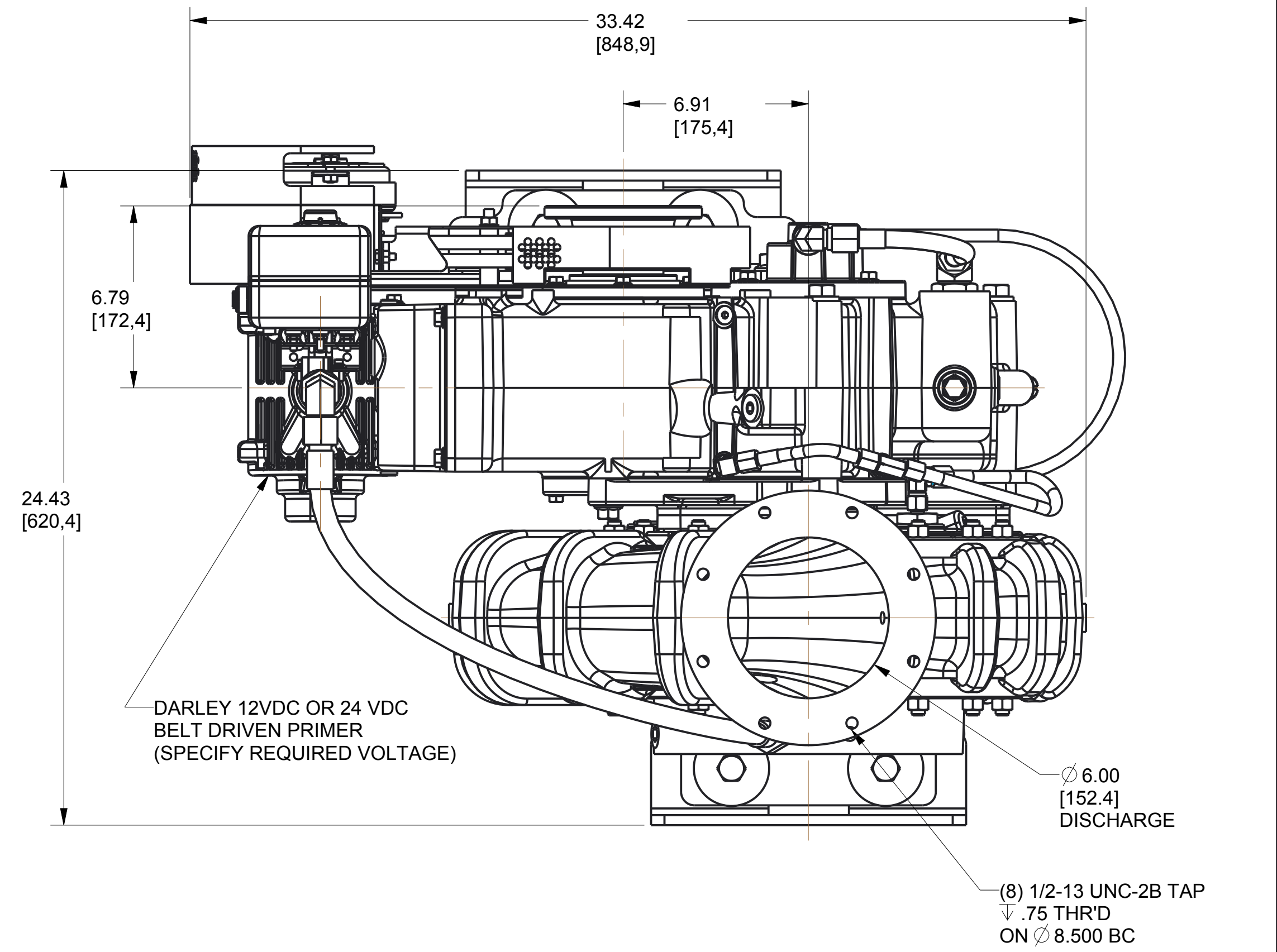

APPROXIMATE WEIGHT 690 LBS [312 KG]

REMOVE SHARP EDGES		INCH [MILLIMETER]	OLD PART NO.	TOLERANCE EXCEPT AS NOTED 00 ±.03 2000 ±.010 ANGLES ±.1°	W.S. Darley & Co. ITASCA, IL - CHIPPEWA FALLS, WI
MATERIAL DESCRIPTION: AS LISTED	MATERIAL NO.	PATTERN NO.	DWG - ZSP, INPUT LEFT CROSS SECTION	DATE 15-Jul-14	DZD0035
THIS DESIGN IS THE PROPERTY OF W.S. DARLEY AND CO. - UNAUTHORIZED REPRODUCTION IS PROHIBITED		ALL DIMENSIONS IN INCHES UNLESS NOTED	DO NOT SCALE PRINT	SCALE 1/4	

MODEL NAME: DZD0035  
MEX CREATED: 10JUL2014  
SHEET: 1/1



REVISIONS				
LTR	DESCRIPTION	DATE	CHG NO.	APPRD

OPTIONAL PUMP CASING POSITIONS  
DISCHARGE CENTERED TO SUCTION

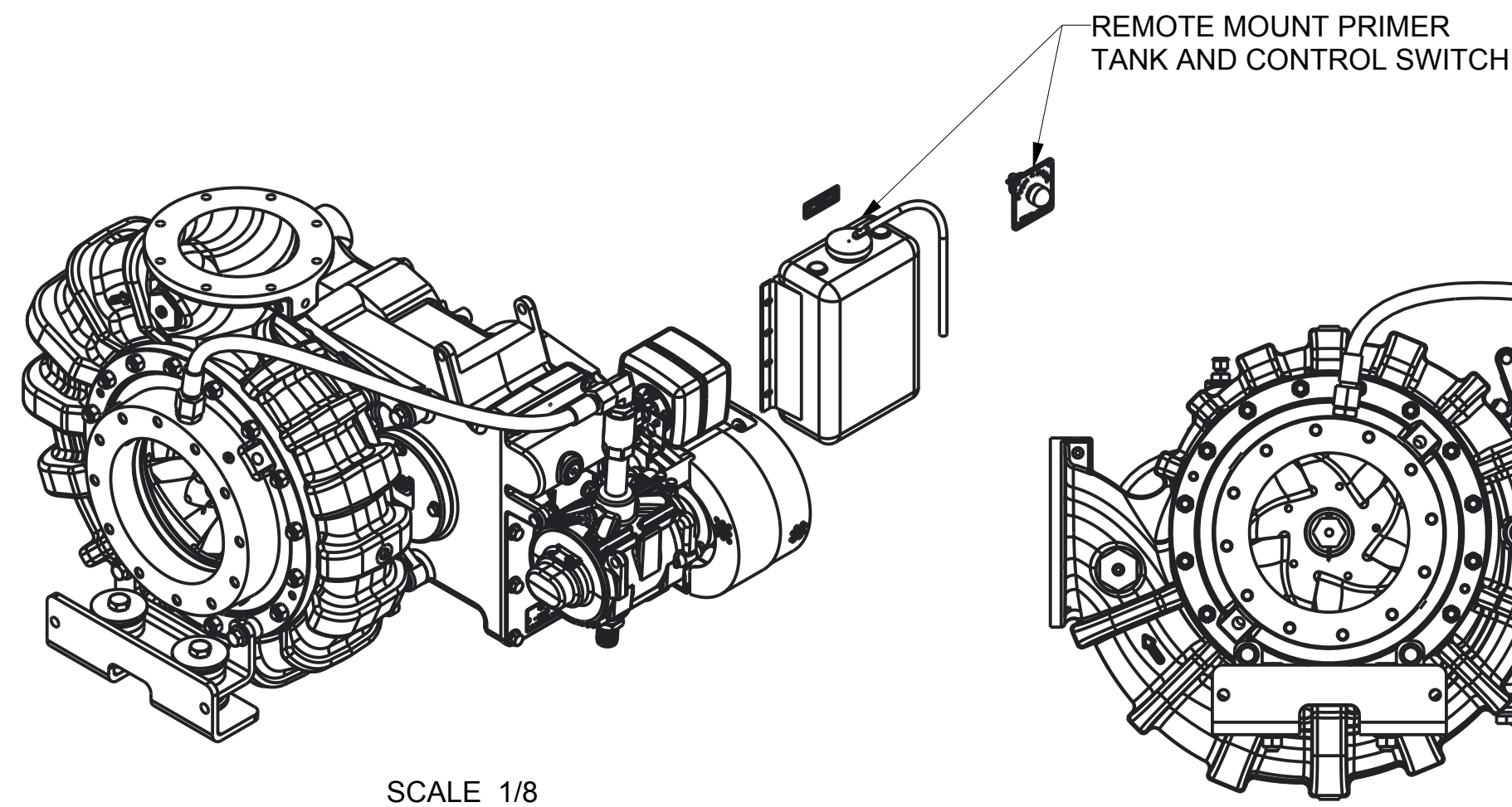

SCALE 1/8

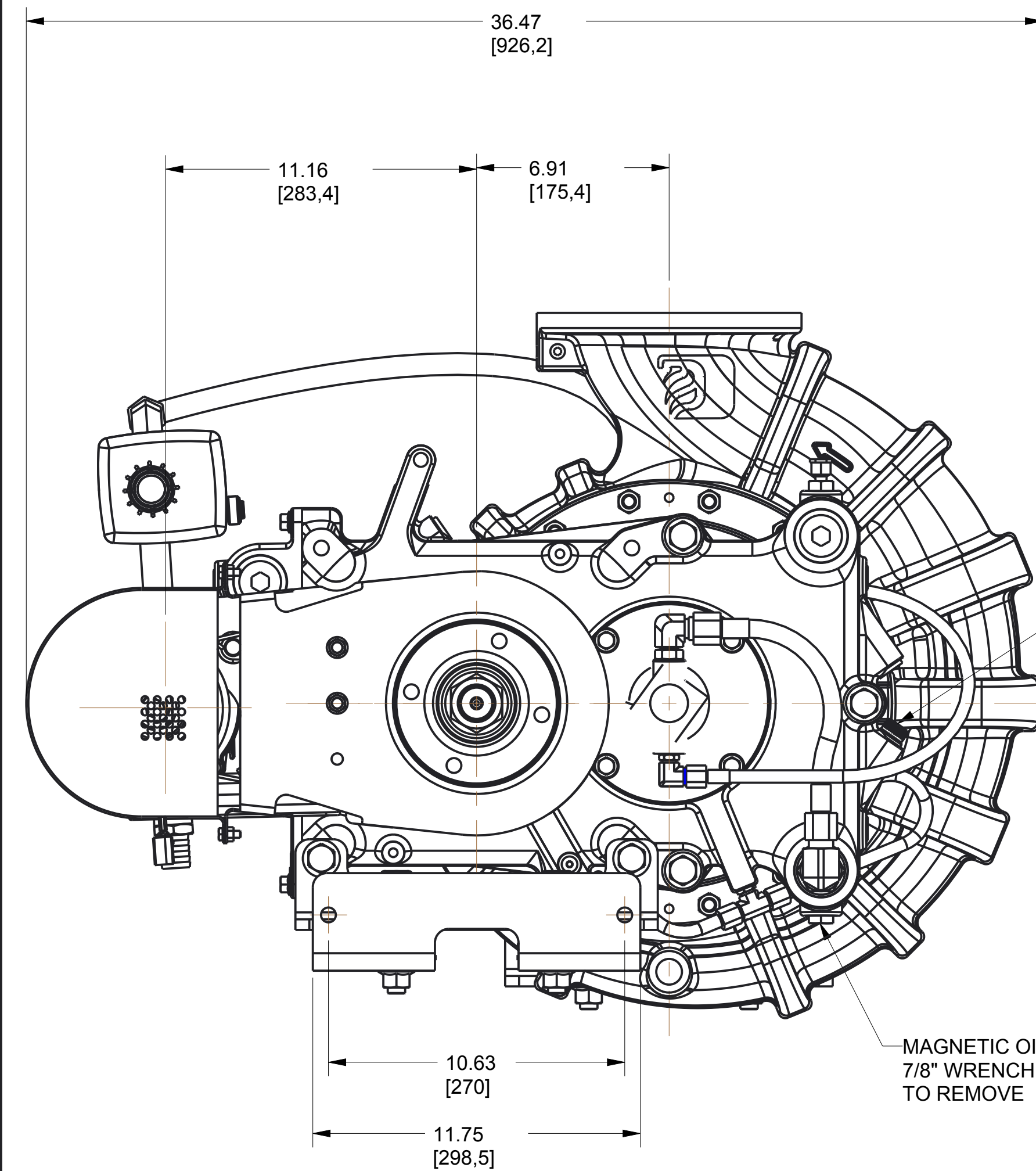
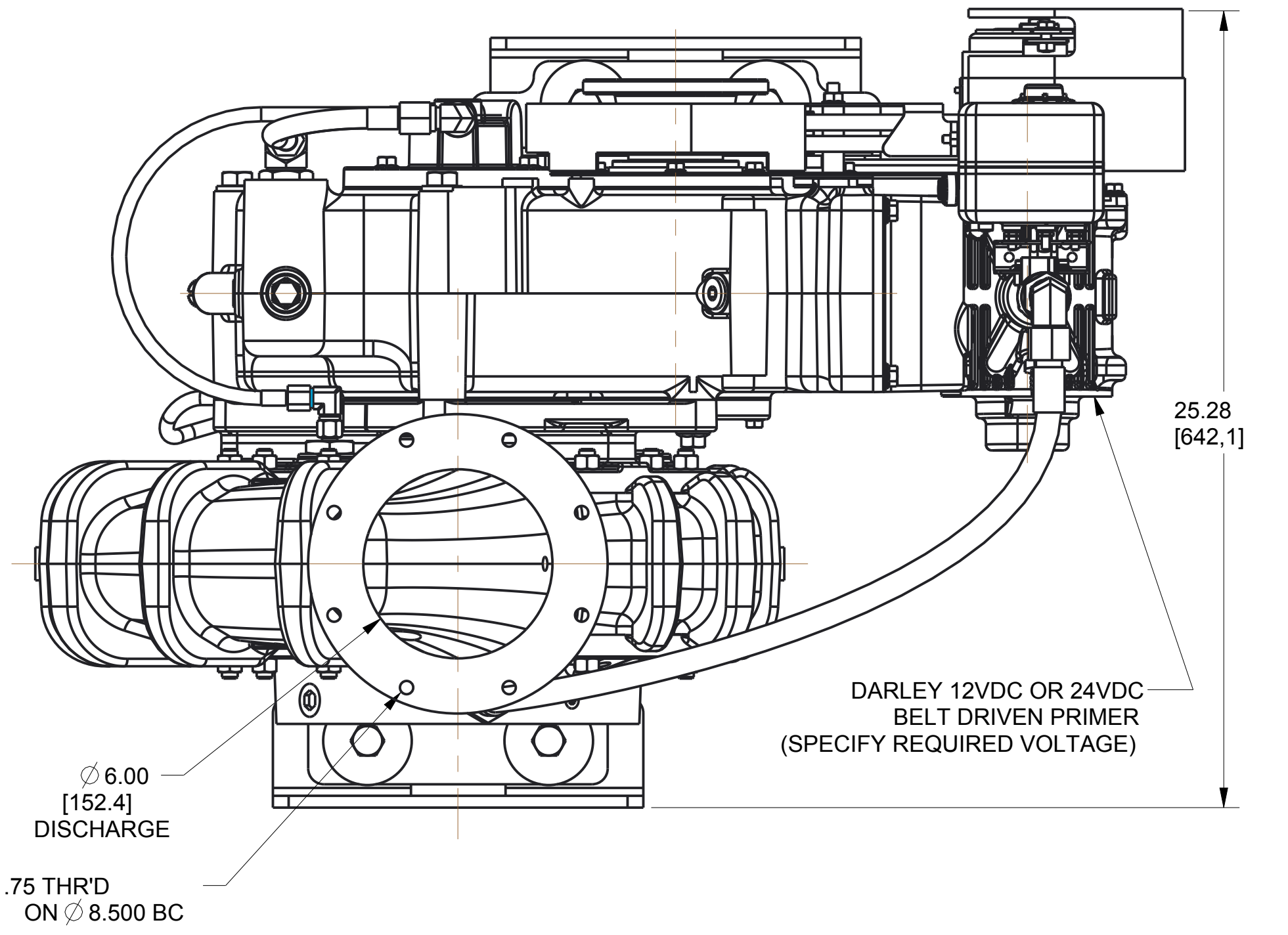
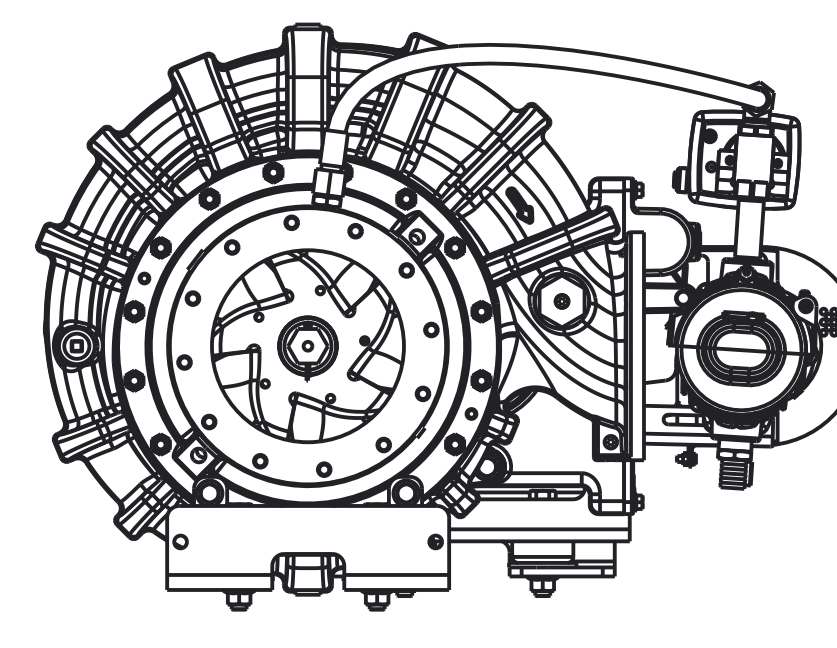
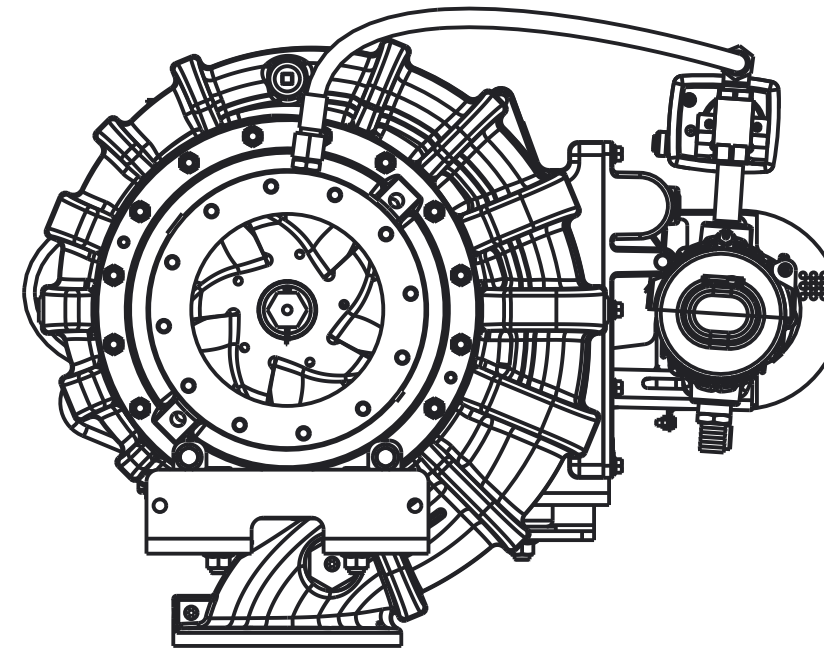
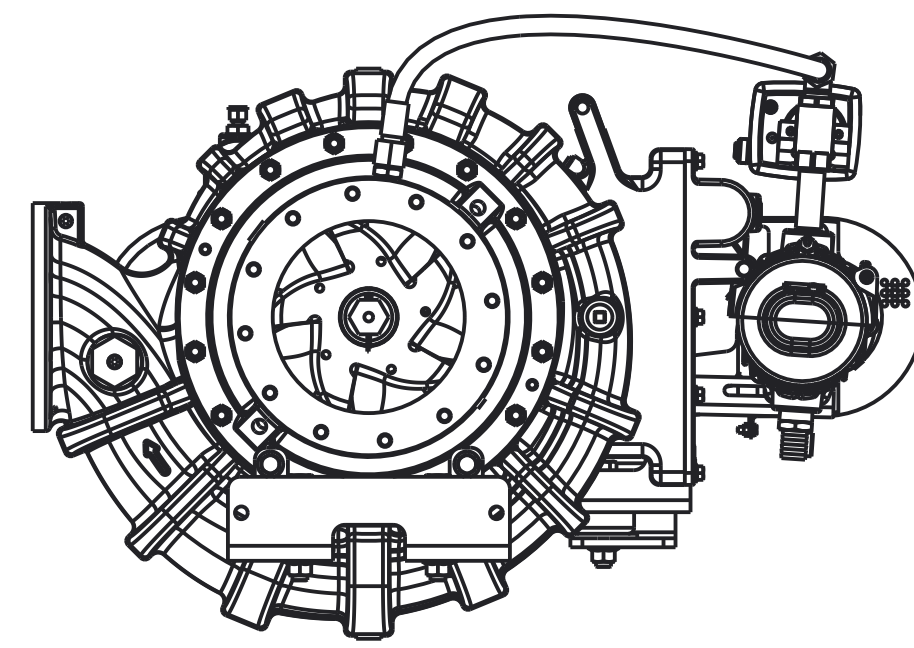

APPROXIMATE WEIGHT 690 LBS [312 KG]

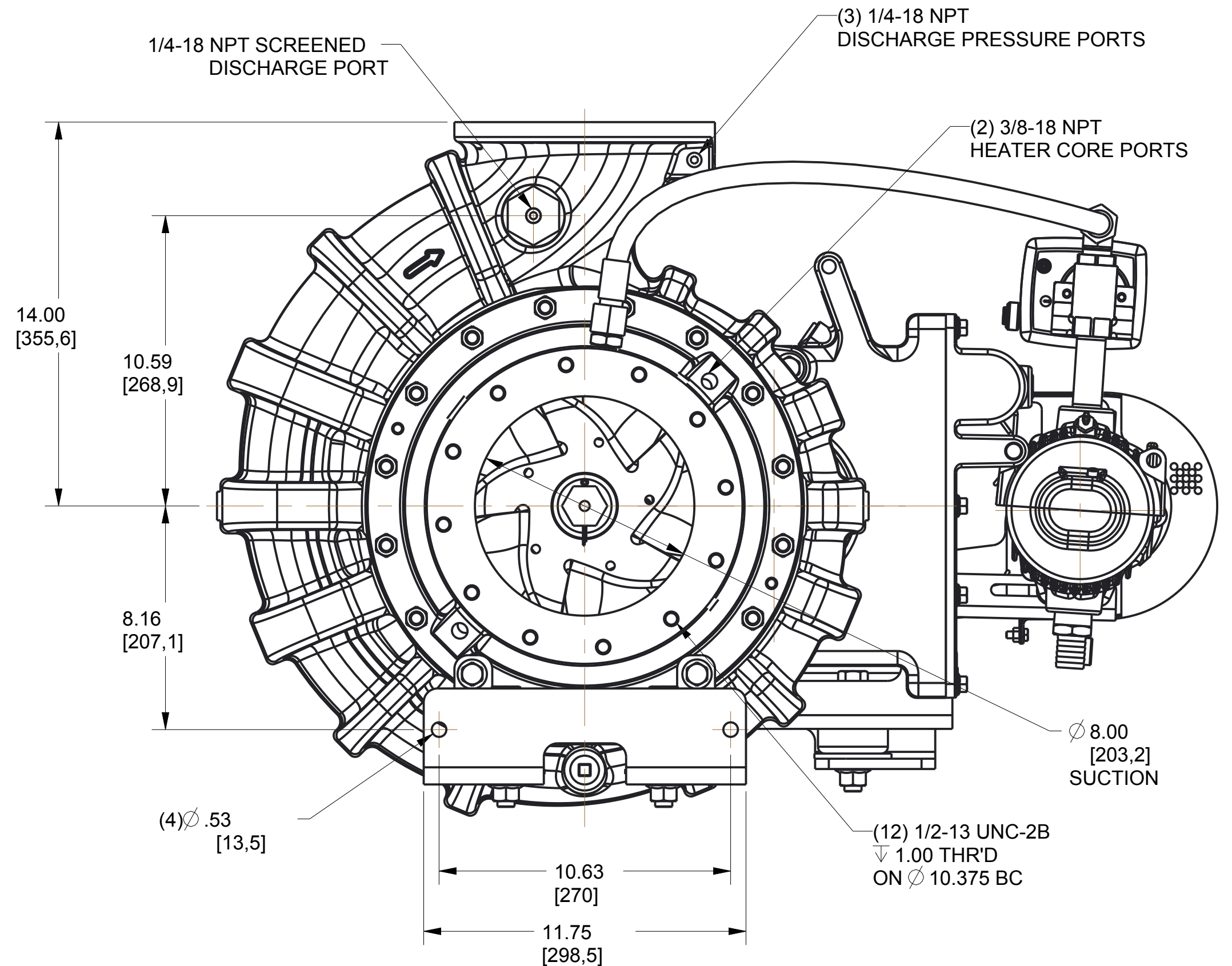
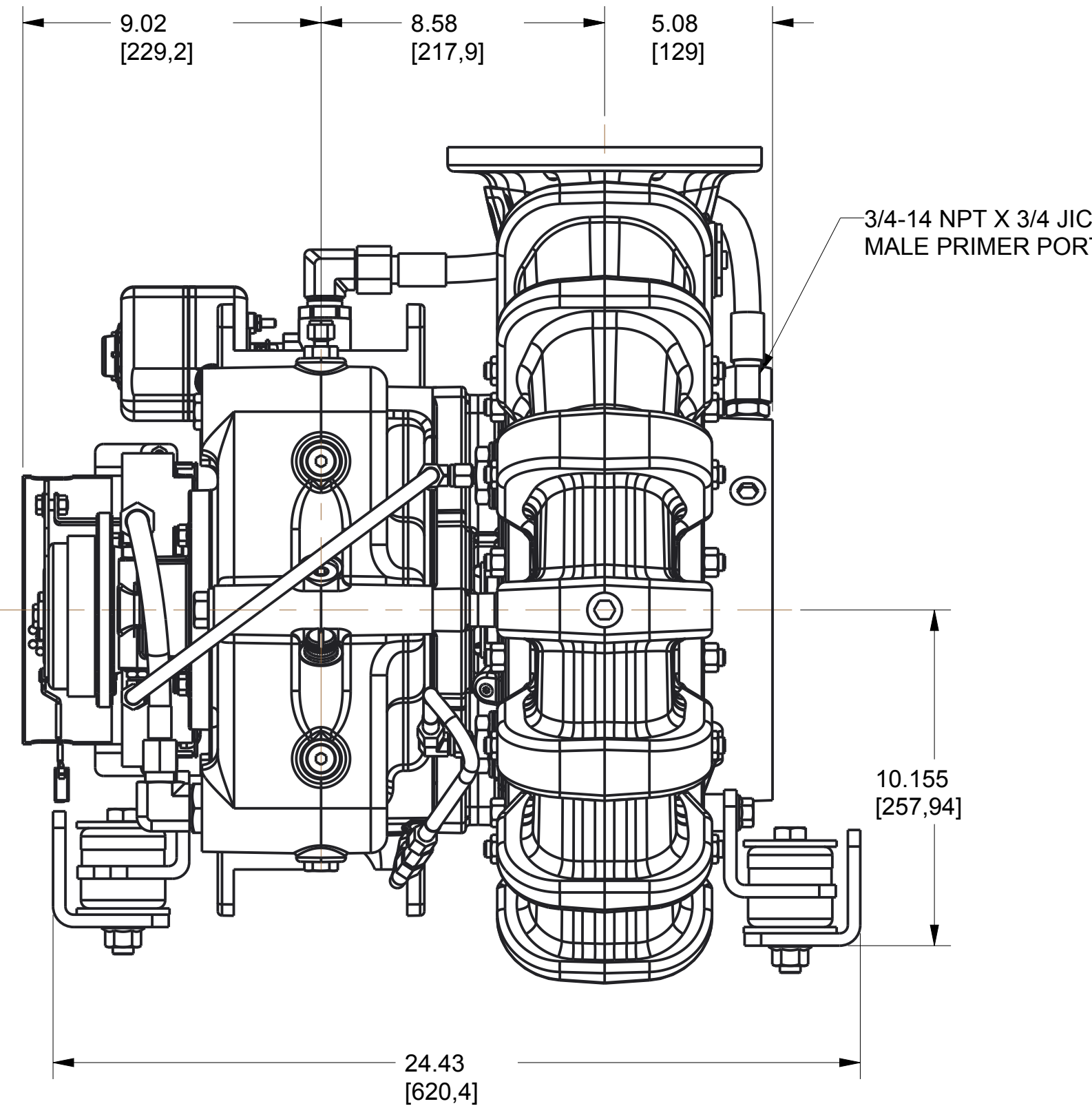

REMOVE SHARP EDGES		INCH [MILLIMETER]		TOLERANCE EXCEPT AS NOTED		OLD PART NO.		TOLERANCE EXCEPT AS NOTED		W.S. Darley & Co. ITASCA, IL - CHIPPEWA FALLS, WI	
MATERIAL DESCRIPTION: AS LISTED		MATERIAL NO.		PATTERN NO.		DWG - ZSP, INPUT RIGHT CROSS SECTION		DATE 15-Jul-14		DZD0036	
THIS DESIGN IS THE PROPERTY OF W.S. DARLEY AND CO. - UNAUTHORIZED REPRODUCTION IS PROHIBITED		ALL DIMENSIONS IN INCHES UNLESS NOTED		DO NOT SCALE PRINT		DRN SMS		CHKD		SCALE 1/4	



REVISIONS				
LTR	DESCRIPTION	DATE	CHG NO.	APPRD

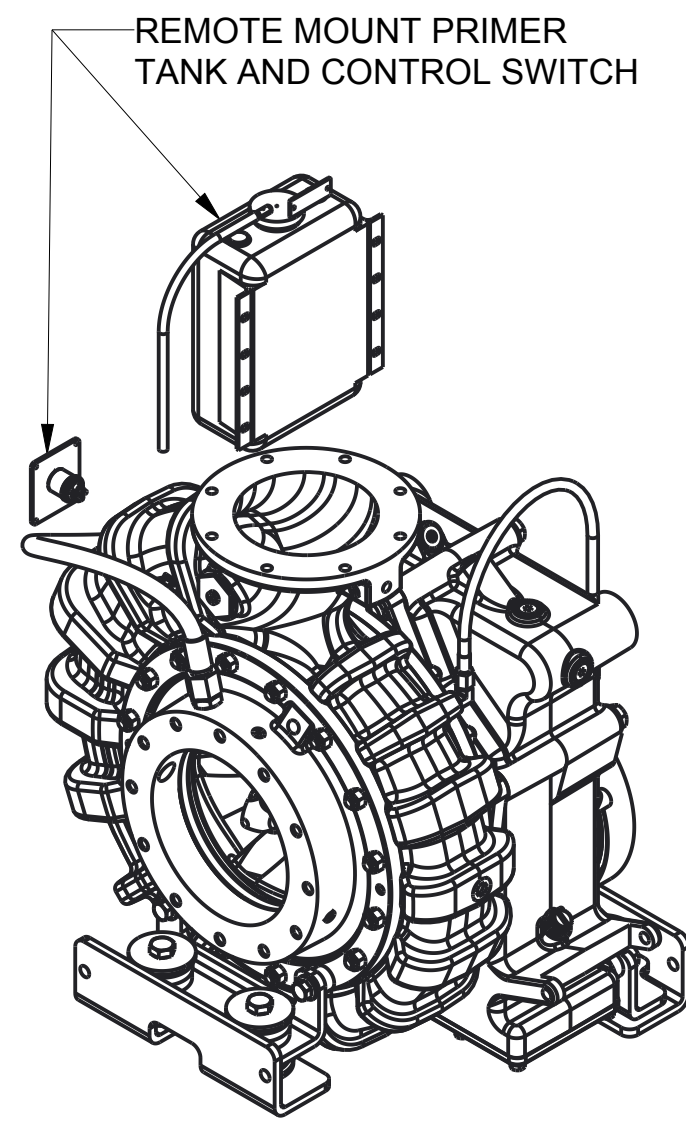

SCALE 1/8

OPTIONAL PUMP CASING POSITIONS  
DISCHARGE CENTERED TO SUCTION

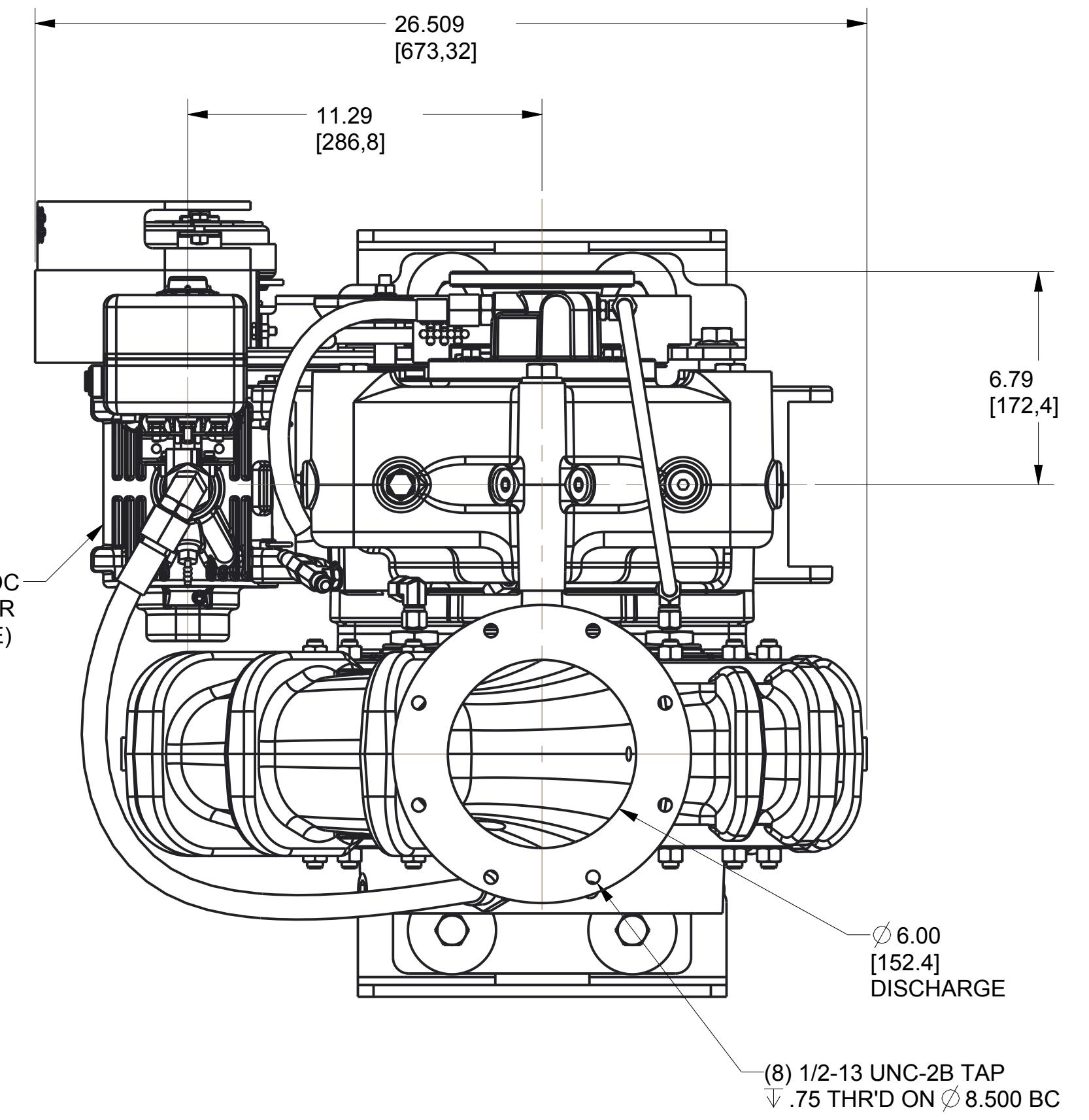
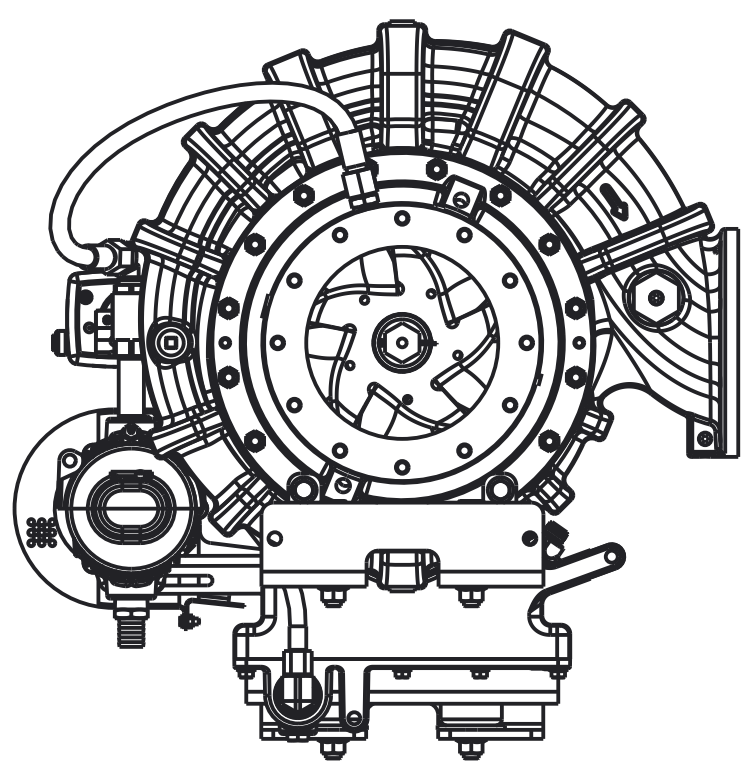
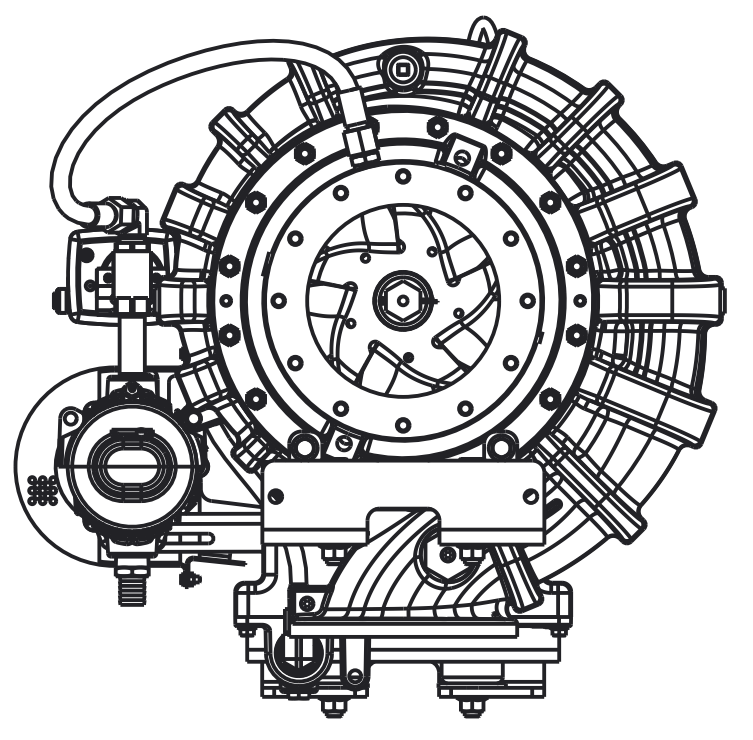
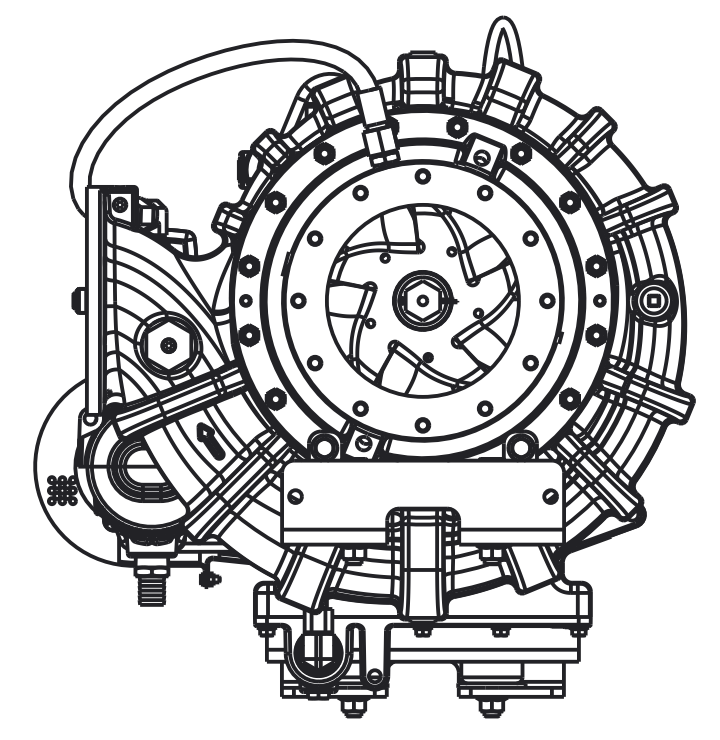

DARLEY 12VDC OR 24VDC  
BELT DRIVEN PRIMER  
(SPECIFY REQUIRED VOLTAGE)

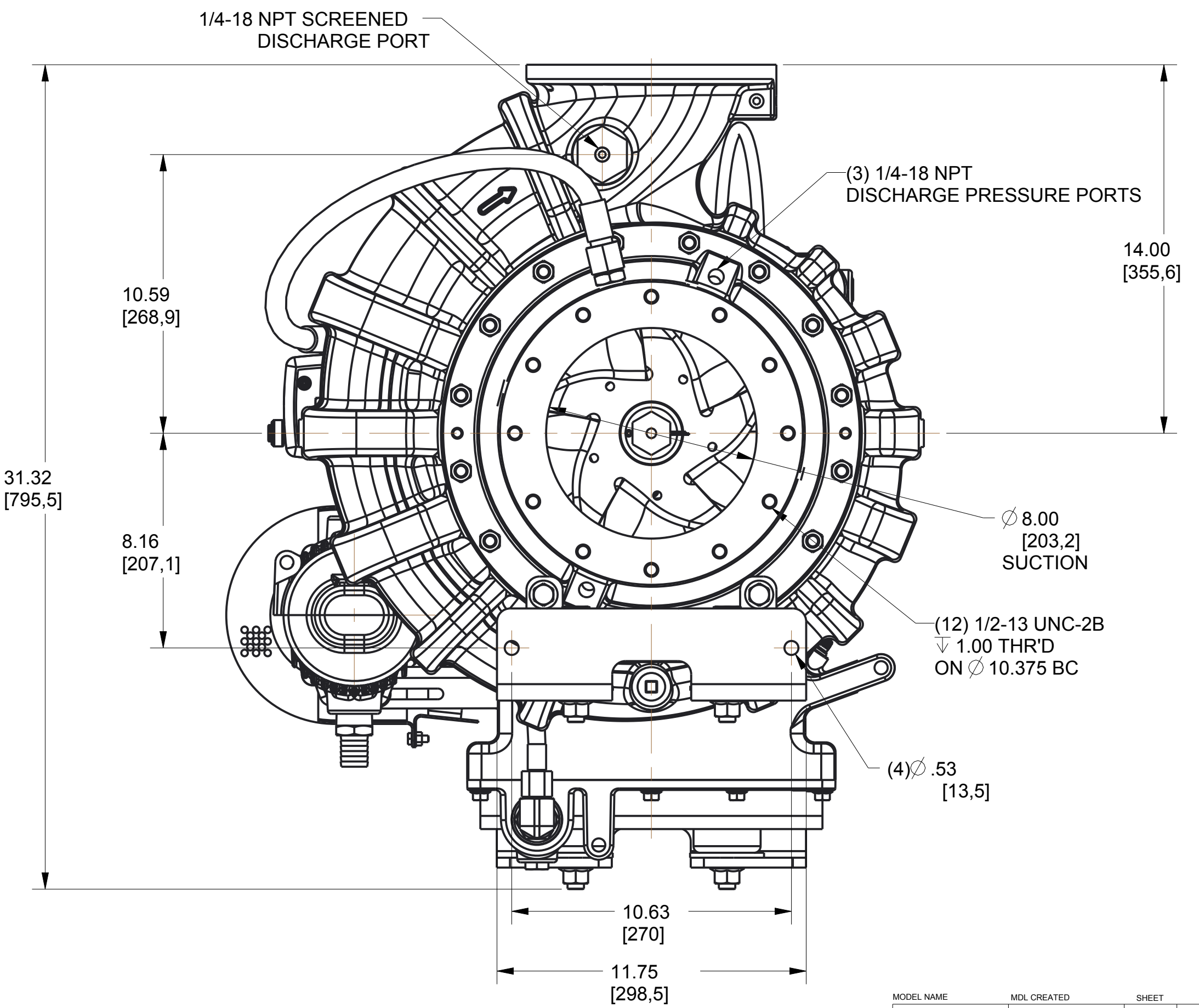
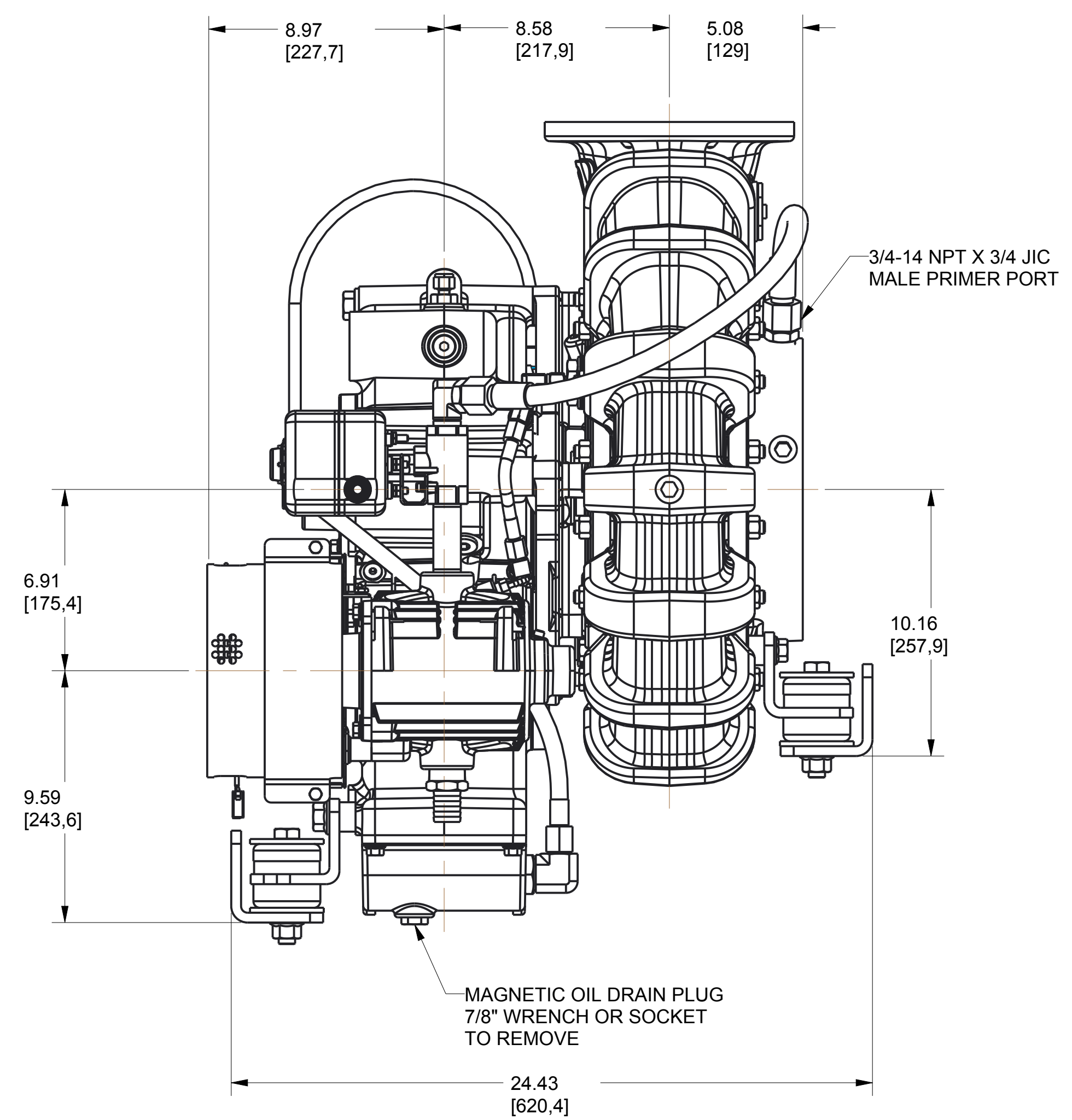
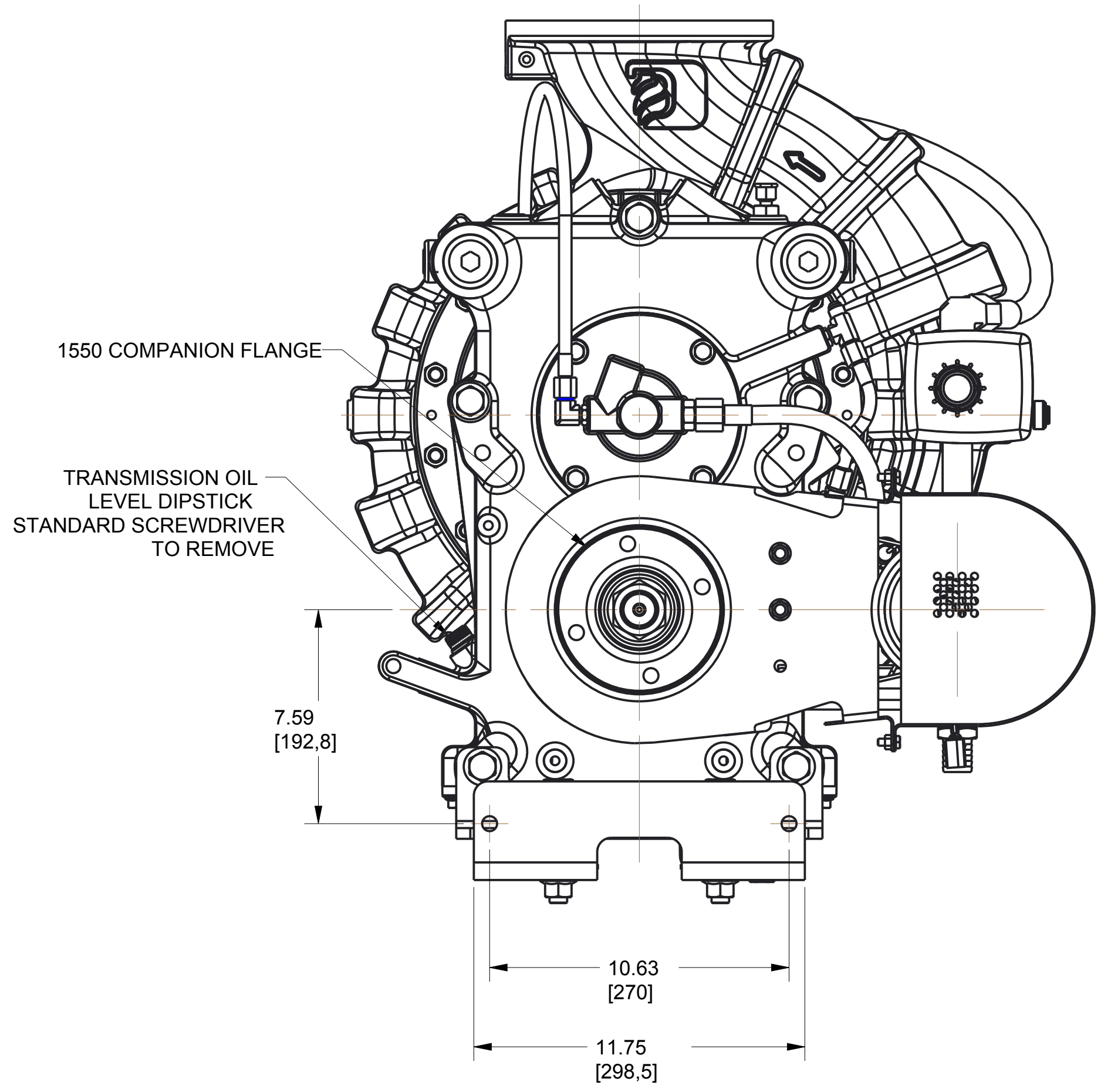

APPROXIMATE WEIGHT 690 LBS [312 KG]

REMOVE SHARP EDGES		INCH [MILLIMETER]	OLD PART NO.	TOLERANCE EXCEPT AS NOTED	 ITASCA, IL - CHIPPEWA FALLS, WI DWG - ZSP, INPUT STANDARD CROSS SECTION
MATERIAL DESCRIPTION:	AS LISTED		MATERIAL NO.	PATTERN NO.	
THIS DESIGN IS THE PROPERTY OF W.S. DARLEY AND CO. - UNAUTHORIZED REPRODUCTION IS PROHIBITED		ALL DIMENSIONS IN INCHES UNLESS NOTED	DO NOT SCALE PRINT	DRYV SMS CHKD WAH TRCD	DATE 15-Jul-14 SCALE 1/4

DZD0037

# ***MECHANICAL SEAL***

Prepared by: RJG  
Approved by: WAH  
Revised by: WAH Via ECO 11337

Rev. A  
Date: 03/16/12  
Rev. Date: 02/19/2016  
1200643.doc



## **Mechanical Shaft Seal**

This pump assembly incorporates high quality mechanical shaft seal(s) separating the pump housing components from atmosphere. Depending on the pump design, there may be one or two seals on each impeller shaft.

The seal size, design type, component materials, and housing configuration have been specifically designed for this pump application and rated operating parameters.

## **Mechanical Seal Basics**

A mechanical seal is a device that houses two highly polished components (known as faces). One face rotates, the other is stationary. A secondary elastomer bellows seals the primary ring to the shaft. An o-ring or cup seal seals the mating ring in the housing. The polished seal faces of the primary and mating rings are pressed together by a spring mechanism to provide adequate force to affect a seal. The force acting between the seal faces increases in direct proportion to product pressure.

The elastomer bellows seal utilized in this pump has the following design features:

- Mechanical drive of the primary seal ring. The drive band's notch design eliminates overstressing the elastomer sealing bellows.
- Bellows design provides automatic compensation for shaft endplay, run out, and primary ring wear.
- Seal face contact pressure is controlled by a single, non-clogging coil spring. This coil spring has been custom welded per Darley specifications to eliminate high-speed spring distortion.

The seal housing is designed and ported to provide optimal water flow and pressure assuring proper cooling and flushing of the seal components.

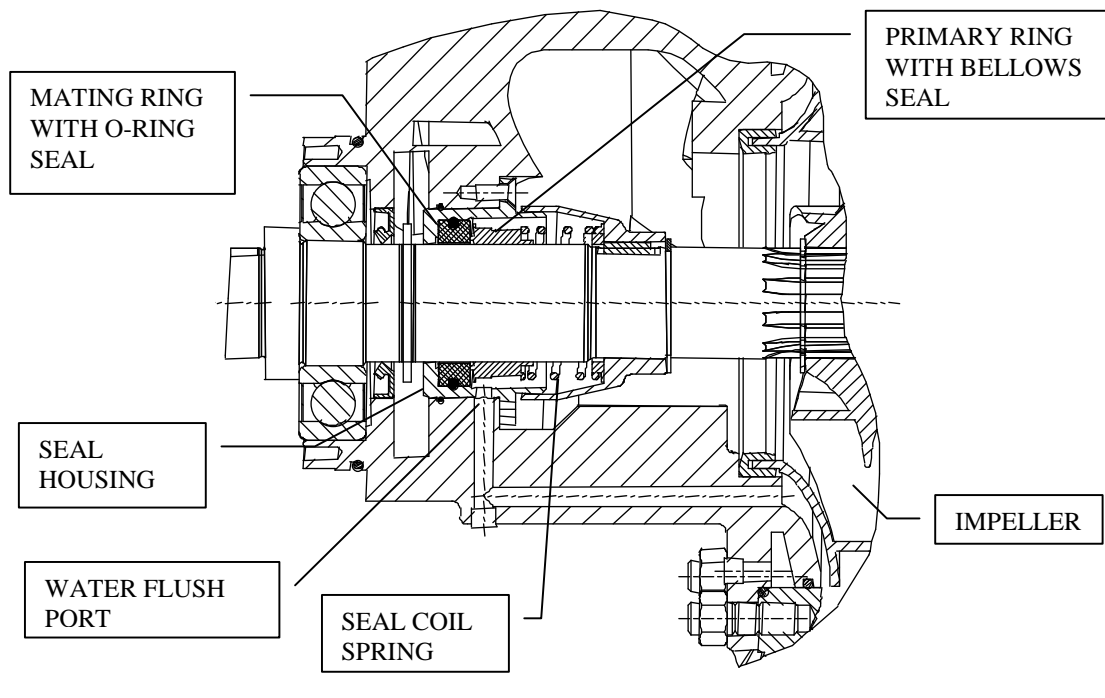

## **Operation and Maintenance**

When operated within rated operating conditions of this pump, these seals will provide trouble free service for extended periods.

Properly selected and applied mechanical shaft seals are leak free and require no adjustment. Should the seal area develop a leak, investigate the cause as soon as possible. Seal failure, leakage, may be the result of; worn seal faces, leaking bellows, or damaged o-rings. These failures may be attributed to bearing failure, impeller blockage, impeller imbalance, seal housing contamination, operating beyond pump design rating, or dry running,

Mechanical shaft seal design relies on the sealed media, in this case, water, to cool and lubricate the sealing surfaces. Therefore, extended dry operation may cause overheating and scoring or damage to the sealing surfaces, resulting in excessive leakage or a much shortened seal life.

To maximize seal life, minimize operation at pump pressures higher than pump rating. While operating at pressures beyond rating will not immediately damage the seal, it will increase sealing surface wear rate.



**CAUTION:** DO NOT RUN THE PUMP DRY EXCEPT MOMENTARILY AND AT LOW SPEEDS



**CAUTION:** DO NOT USE THIS PUMP FOR HOSE TESTING



**CAUTION:** THE MECHANICAL SEAL SHOULD NOT BE RUN DRY, WHILE THE PUMP IS NOT ENTRAINED WITH WATER, FOR A PERIOD LONGER THAN 2 MINUTES. FAILURE TO FOLLOW THIS RECOMMENDATION WILL LEAD TO PREMATURE WEAR AND FAILURE OF YOUR MECHANICAL SHAFT SEAL.



# DARLEY

## INSTALLATION OF MECHANICAL FACE SEAL WITH O’RING

### SPECIAL HANDLING

Study the engineering layout before installing the seal. This shaft seal is a precision product and should be handled and treated with care. Take special care to prevent scratches on the lapped faces of the primary and mating ring. Provide a very clean work area where the assembly will take place. Clean hands prior to assembly.

### INSTRUCTION STEPS:

#### Instructions for Installing a Mechanical Shaft Seal

1. Inspect mating ring pocket in seal housing ensuring it is clean, free of chips, and nick free, to provide a proper sealing surface. Isopropyl alcohol may be used to clean the surfaces if required.

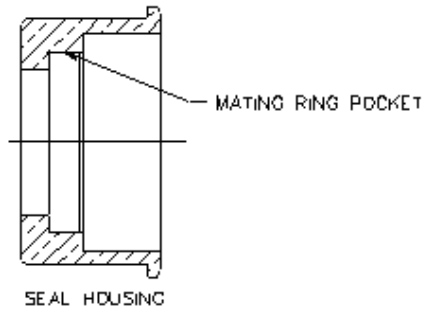

2. Inspect the pump shaft surface under the bellows, ensuring it is clean and nick free to provide a proper sealing surface. Isopropyl alcohol may be used to clean surface if required.

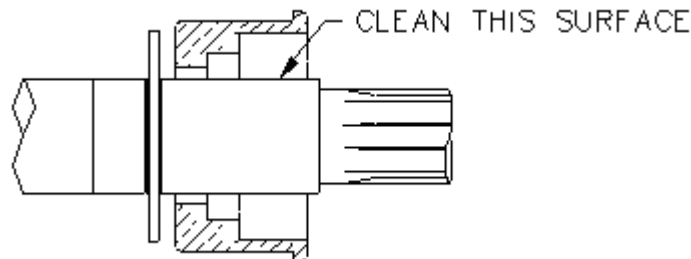

3. Lightly lubricate the entire o-ring on the mating ring with a single drop of P-80 water soluble rubber lubricant - evenly distributed (do not over lubricate) and push it into the cavity using the recommended installation tool or other suitable plastic tube free of contaminants, firmly seating the mating ring square. Be careful not to get the P80 on either face. If P-80 is on either face, remove it from the faces prior to installation.

Note: The polished face of the mating ring must face out – away from the pump’s gear case. Try to not touch the polished sealing face with your fingers; the oils from your fingerprint can cause the seal to leak. Remove any P-80 from the sealing face after installation.

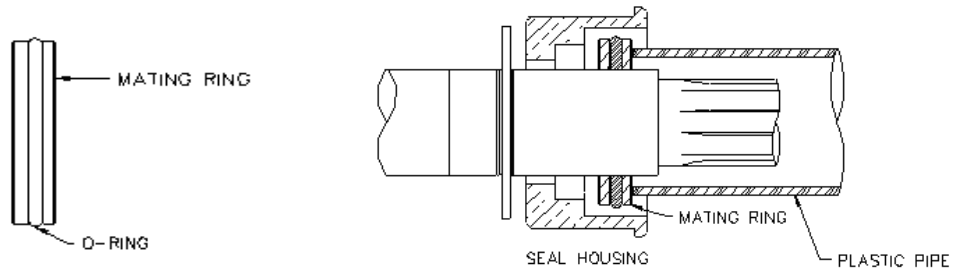
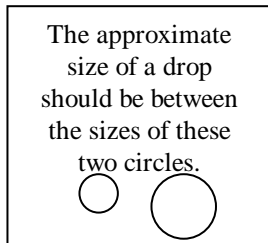

4. Clean the mating ring surface with isopropyl alcohol to remove any fingerprints and any other contaminants left on mating ring.

Note: Steps 5 – 9 need to all be completed with in 15 minutes or less.

5. Apply a small drop of P-80 rubber lubricant or water-soluble lubricant (not soapy water) evenly distributed to the inside diameter of the bellows assembly allowing it to be pushed easily into position.
6. Clean the polished sealing face of the primary ring with a clean lint free rag with isopropyl alcohol to remove all fingerprints and other contaminants.

The approximate size of a drop should be between the sizes of these two circles.



7. Slide a seal save, similar to X6550, over the shaft splines to ensure that the seal is not damaged during installation. Place the primary ring and lubricated bellows assembly (without the spring) on the shaft, using a proper pusher - push the assembly into position so that the seal surfaces are in contact. Remove the seal save from the shaft.

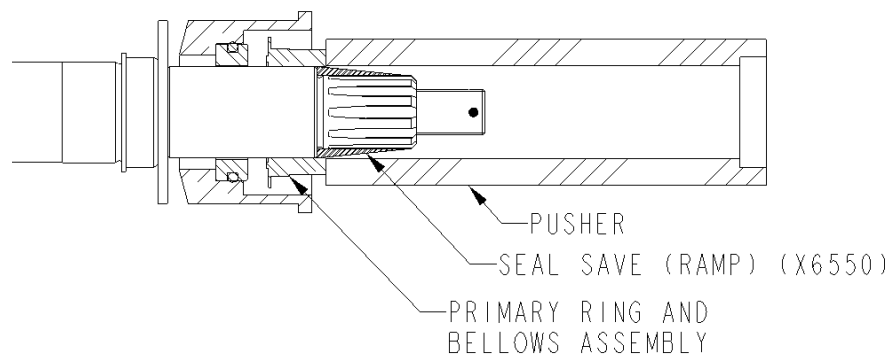

8. Put the spring in place, seated tight against the spring retainer on the primary ring.  
Note: Some springs may be slightly tapered, so one end fits the seal better than the other. The end of the spring that best fits the seal should go towards the seal to ensure even spring pressure all the way around.
9. Slide impeller onto impeller shaft, engage the spring into the groove of the impeller hub and install impeller washer, impeller nut, and stainless-steel cotter key.

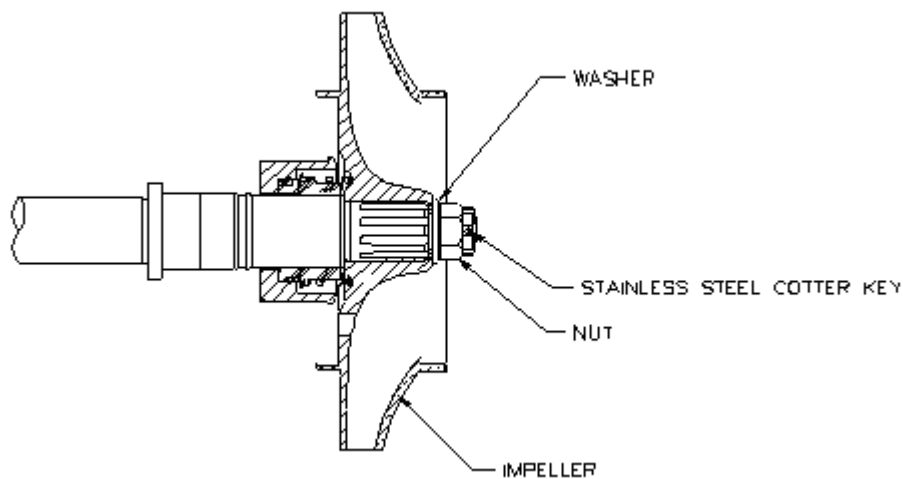

\*\* Reference pump configuration for individual mechanical seal instructions.

\*\* Reference pump assembly drawings and pump assembly tips for further assembly.

Note: If the seal leaks slightly after assembly, it may be necessary to run the pump for approximately 30 minutes at 50-60 psi to rinse out excess lubricant and other contaminants.

Once a mechanical seal has been installed, it is recommended that it not be reused.

If further information is needed, call **DARLEY** in  
Chippewa Falls, WI. at 800-634-7812 or 715-726-2650



***ELECTRICALLY-CLUTCHED  
BELT-DRIVEN  
ROTARY VANE  
PRIMER***

Prepared by: RJG  
Approved by: WAH  
Revised by: WAH Via ECO 11337

Rev. A  
Date: 03/16/12  
Rev. Date: 02/19/2016  
1200643.doc

# W.S. DARLEY & CO.

## Operating/Troubleshooting Instructions for Darley Electrically-Clutched Belt-Driven Priming Pump

The Darley electrically-clutched belt-driven primer will develop up to 25 in. Hg. in an air tight pumping system.

The Primer is activated by a push-button momentary electric switch. Pushing and holding this switch in opens the 12/24 VDC electric  $\frac{1}{4}$  turn  $\frac{3}{4}$ " ball valve and closes the electrical circuit to energize the clutch, engaging the belt drive system, in turn spinning the primer rotor within the primer body. Releasing this switch will close the  $\frac{1}{4}$  turn electric valve and disengage the primer clutch, ending the priming cycle.

The 12/24 VDC electric  $\frac{1}{4}$  turn valve utilized in this system has a 0.8 second cycle time as well as a logic controller to make necessary adjustments internally depending on input voltage, therefore maintaining a constant 0.8 seconds open/close cycle time. This valve will act as a bubble tight check valve, therefore once the momentary push to prime switch is released, this  $\frac{1}{4}$  turn valve will automatically close and contain the prime of the pump system.

Before the pump can be primed, booster line valves, drain valves, cooling line valve, and all other openings into the pump must be closed and absolutely air tight. In cases where the discharge side of the pump is sealed by a check valve, the main discharge valves need not be closed.

When operating from draft, suction hose connections must be tight and free of air leaks.

Make certain the suction hose strainer is properly submerged and free of foreign material.

The main pump drive must be engaged to initiate priming

### CAUTION

#### FOR ALL PRIMING SCENARIOS:

If water does not discharge from the primer exhaust within 80 seconds stop the primer pump, check for air leaks and resolve the issue before attempting to re-prime. **MAX PRIMER OPERATION TIME = 80 seconds. DO NOT EXCEED 80 SECONDS OF PRIMER OPERATION.** Repeated operation should be avoided.

### CAUTION

The primer pump generates heat as soon as operation begins. Extended run times (up to 80 seconds) and repeating priming cycles consecutively or within short time periods may lead to accelerated wear or premature failure of the primer pump assembly. If an attempt to prime should fail, thoroughly inspect the pump system for air leaks and resolve the issue before attempting re-prime.

## **Priming Procedure:**

To prime the pump a certain amount of dry running of the pump along with a recommended engine speed are given. Significant testing has proven these figures at W.S. Darley and should never be exceeded without W.S Darley Customer Service approval.

Priming time should not exceed 80 seconds. If pump fails to prime within 80 seconds, shut down and thoroughly inspect the pump system for air leaks and resolve the issue before attempting to re-prime.

Engine speed during priming should NOT exceed 1000 RPM regardless of the pump and/or PTO ratio in relation to engine speed.

To Prime: Engage the pump per the shifting procedure outlined in Section 2, and ramp engine speed to no more than 1000 RPM. Press the "Push-to-Prime" momentary switch and hold. Prime should occur within 80 seconds. Indication of Prime should be noticed when water discharges from the primer pump exhaust port. Releasing the momentary switch will disengage the primer clutch and close the primer ¼ turn ball valve. Prime should now be attained and contained.

Under normal conditions, the primer will evacuate the pump and 20' of 8" hose within 24 seconds.

As soon as prime is reached the pump will develop pressure.

When pumping from hydrants, the primer is not needed and must be kept closed.

It may be necessary to use the primer momentarily when pumping from a booster tank when the suction head is insufficient to force all the air out of the pump.

## **Lubricating System – Electric Priming Pump with Fluid Reservoir**

The electrically-clutched belt-driven rotary-vane primer pump creates a high vacuum by continuous lubrication of rotor and vanes. Therefore the primer lubricant supply tanks (4 quarts) should be kept full at all times.

Recommended primer system lubricant is Darley PRIME GREEN. PRIME GREEN is an environmentally safe, non-toxic, biodegradable lubricant. Its use assures proper primer vane lubricant while minimizing environmental effects.

After the main pump is drained, run the primer motor to drain primer lines and re-lubricate the primer pump.

The vent-hole on the lubricant tank cap should be kept open at all times to prevent siphoning of lubricant from the tank after the pump is stopped. Do not increase the size of this hole.

Locate the lubricant tank where it may be conveniently inspected and filled.

Should water appear in the lubricant supply tank, the primer valve is leaking. Check and replace valve plug seal o-rings as necessary.

## **Troubleshooting:**

-If the electric clutch is not functioning / slipping beyond normal operating characteristic:

- Check system supplied voltage. Under a static energized condition the clutch should be pulling 12 VDC @ 4.89 Amps with 2.45 Ohms (+/- 5%) of resistance across the coil and 24 VDC @ 1.26 Amps with 9.51 Ohms (+/- 5%) of resistance across the coil; depending on the clutch (12 or 24 VDC) being used. Note that these figures are at an ambient temperature of 68°F.
- These figures can be checked with the correct measuring/inspection equipment. Such as a properly calibrated Multi Meter with a Current Clamp.
- Any deviation from these figures when experiencing clutch challenges could indicate a problem with the clutch coil or an insufficient supply voltage and current. Contact W.S. Darley Customer Service if these problems occur.

-Vibration in belt/clutch assembly:

- Could be indicated by:
  - Damaged Belt
  - Contaminated Bearing
  - Loose clutch body mounting bolt (through clutch bore into primer rotor/shaft assembly)
  - Loose bolts holding belt tension
    - Revisit the primer assembly drawing and contact W.S. Darley Customer Service if necessary. Proper belt tension is a must.
    - Belt tension can be inspected and validated by:
      - Placing a 6 lb– 7 lb force on the belt along its periphery directly between the center axis of each pulley. The belt should deflect approximately 5/32" +/- .015"; beyond these figures in either direction +/- will yield a belt tension that is too loose or too tight and will detrimentally affect belt, sheave and clutch life.
  - Damaged rotor/shaft assembly
  - Damaged or broken primer vane
  - Particulate trapped in primer/rotor body vane area
  - Excessive slipping in between clutch armature assembly and friction material
    - If this occurs, excessive heat may generate, causing warpage and damage to the armature and friction material
    - Heat signs will show, bluing and blackening of surrounding areas from heat source

- Trapped particulate entrained in air gap (between armature assembly and friction material)
- Damage or Failure of 1, 2 or all 3 of the clutches spring plates.
  - These plates hold the pulley sheave to the armature assembly, transferring rotational energy of the pulley sheave through the belt drive to the clutch friction material (when the clutch coil is energized) and correspondingly through the primer rotor/shaft assembly creating a vacuum in the rotary vane primer pump. These spring plates allow for this transfer as well as allow the energized clutch coil to overcome the spring force in these plates and close the air gap between the armature assembly and the friction material, or vice versa re-establishing the air gap and preventing the belt drive system from transferring rotational energy to the rotary vane primer pump.

-Excessive belt wear

- Could be indicated by:

- Misalignment between Driver and Driven pulleys

- Axial or Angular

- Revisit the primer assembly drawing and contact W.S. Darley Customer Service if necessary. Belt drives must have nearly zero misalignment for long life and proper function.

-Minimal vacuum creation by Primer

- Damaged vanes

- Loss of original lubrication in primer rotor housing and vanes

- Particulate trapped in vane housing

- Causing vane(s) not to fully engage and disengage in vane housing/rotor

- Would prevent vacuum creation or severely inhibit such

- Other challenges may occur that have not been listed here, we kindly ask that you document these challenges as best you can and contact W.S. Darley Customer Service to identify the root cause and evaluate any necessary changes in the design.

*For challenges and assembly/disassembly assistance:*

**CONTACT DARLEY CUSTOMER SERVICE IMMEDIATELY AT 1-800-634-7812 or 715-726-2650**



NO.	DESCRIPTION	PART NO.	QTY.
1	ASSY - ROTOR, 25 CU IN VAC PUMP	4434310	1
2	BEARING - OILITE, 1.000 ID	1760006	1
3	BEARING - OILITE, 1.250 ID	1760033	1
4	BELT - PRIMER DRIVE	4226905	2
5	BRACKET - BELT COVER	4027904	1
6	CLUTCH - VAC PUMP, 24VDC	4227011	1
7	COVER - BELT	2505406	1
8	COVER - BELT	2505405	1
9	CYLINDER - VACUUM PUMP, 25 CU IN	1021203	1
10	FITTING-.75NPTx.75JICM	3501553	1
11	FTG - BARB, 1.00 ID X 1.00 NPT MALE	3502031	1
12	FTG-.75NPTMX1 1/16-12JICM RIGD	3501638	1
13	HEAD - CYL, VAC PUMP, 25 CU IN	2813803	1
14	HHCS - .25-20 X .63, GR 5 SST	5400603	2
15	HHCS - .250-20 x 0.63, GR5	5400001	2
16	HHCS - .313-18 x 0.75, SST	5400641	1
17	HHCS - .438-20 x 2.75, GR5	5400118	1
18	HHCS - FLANGED, .313-18 X 1.00	5402843	3
19	HHCS - FLANGED, .313-18 X 1.25	5402844	4
20	HHCS - FLANGED, .375-16 X .88	5402835	1
21	HHCS - FLANGED, .375-16 X 2.00	5402871	1
22	NIPPLE - PIPE, .75 X 3.50, BR	1081042	1
23	NUT - FLANGED TOP LOCK	5403468	2
24	NUT - HEX, .313-18, NYLOC, SST	5403400	1
25	O-RING - 4.75 x 4.94 x 0.09	3601114	1
26	PIN - CLEVIS, .5"	4401501	2
27	PIN - COTTER, .125 SST HAIRPIN	3605213	2
28	PLATE - PRIMER, PUSH BUTTON	1978500	1
29	PLATE - PRIMER LUBRICANT TANK	1963400	1
30	PULLEY - PRIMER DRIVE	4822600	1
31	RETAINER - BEARING, PRIMER CLUTCH	2314400	1
32	SEAL - FURON MECHANICAL, 1.250	1843403	1
33	SHCS - .250-20 x 0.37 SST	5401400	1
34	SPACER - .406 X .88 X .800	3309001	1
35	SPACER - 0.49 x 0.68 x 2.12	3306724	2
36	STRAP - CLUTCH ANTI-ROTATION	4038110	1
37	STRAP - PRIMER SUPPORT, ZSE	4038013	1
38	SWITCH - C7H, PUSH-BTN	2600008	1
39	TANK - PRIMER, 4 QUART, W/CAP	4403703	1
40	TUBE - PRIMER CONNECT	4434801	1
41	TUBE - ROUND, 0.19 X 6', NEO	1101937	1
42	TUBE FITTING - STR, .25 X .19	3500021	1
43	VALVE - ACTUATED, 12/24VDC, .75NPT FE	5209404	1
44	VANE - ROTOR, 25 CU IN, .1905 THICK	4434200	4
45	WASHER - 1.00 x 1.50 x .273 SS	3603342	1
46	WASHER - FLAT, 0.31 ID, SST	3603812	1
47	WASHER - FLAT, 3/8, STEEL	3603803	2
48	WASHER - LOCK, 0.250 ID, SST	3603532	2
49	HHCS - FLANGED, .313-18 X .750	5402833	6

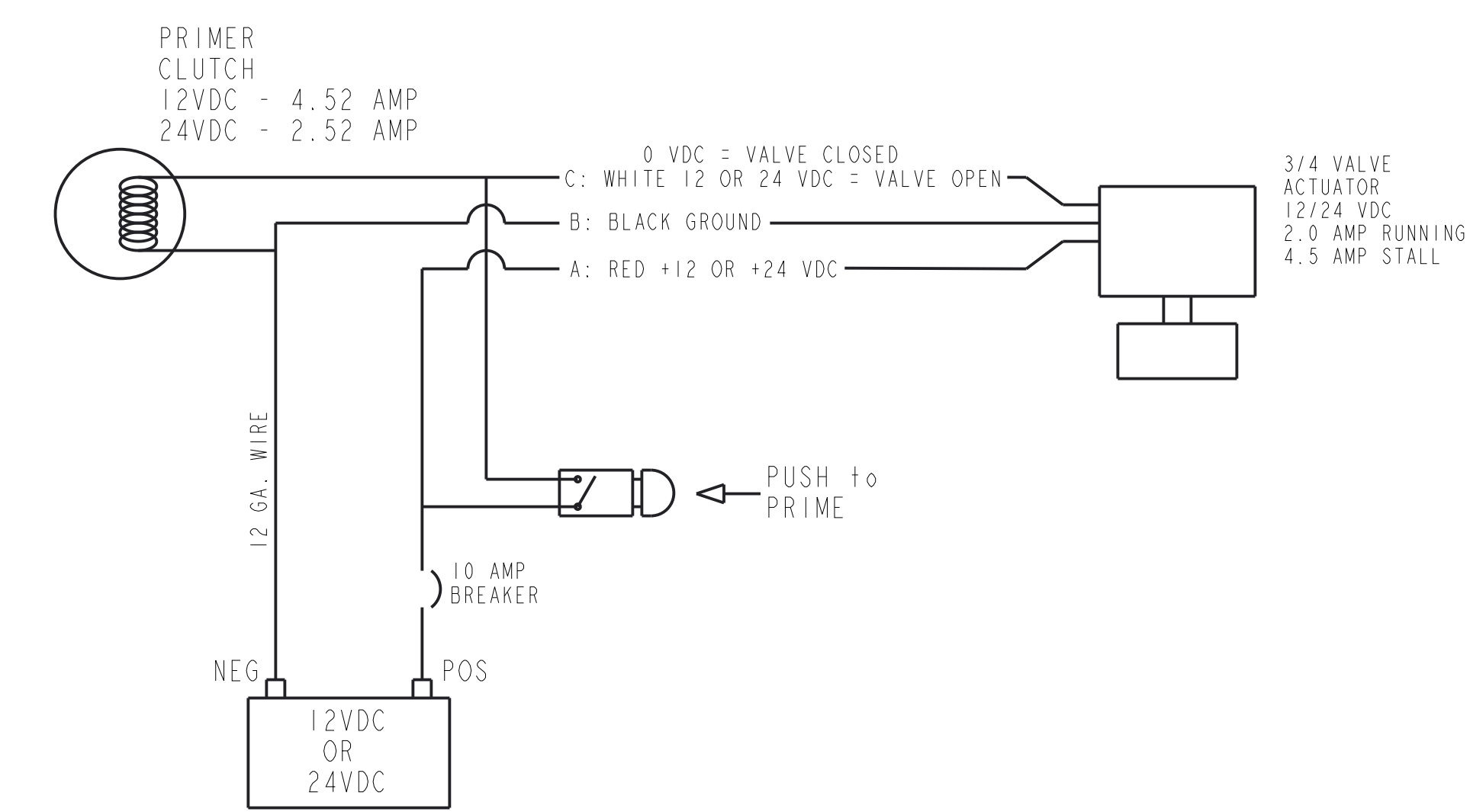

NOTE:  
1) PRIMER ASSEMBLY IS EITHER 12 VOLT OR 24 VOLT AND MUST BE SPECIFIED UPON ORDER

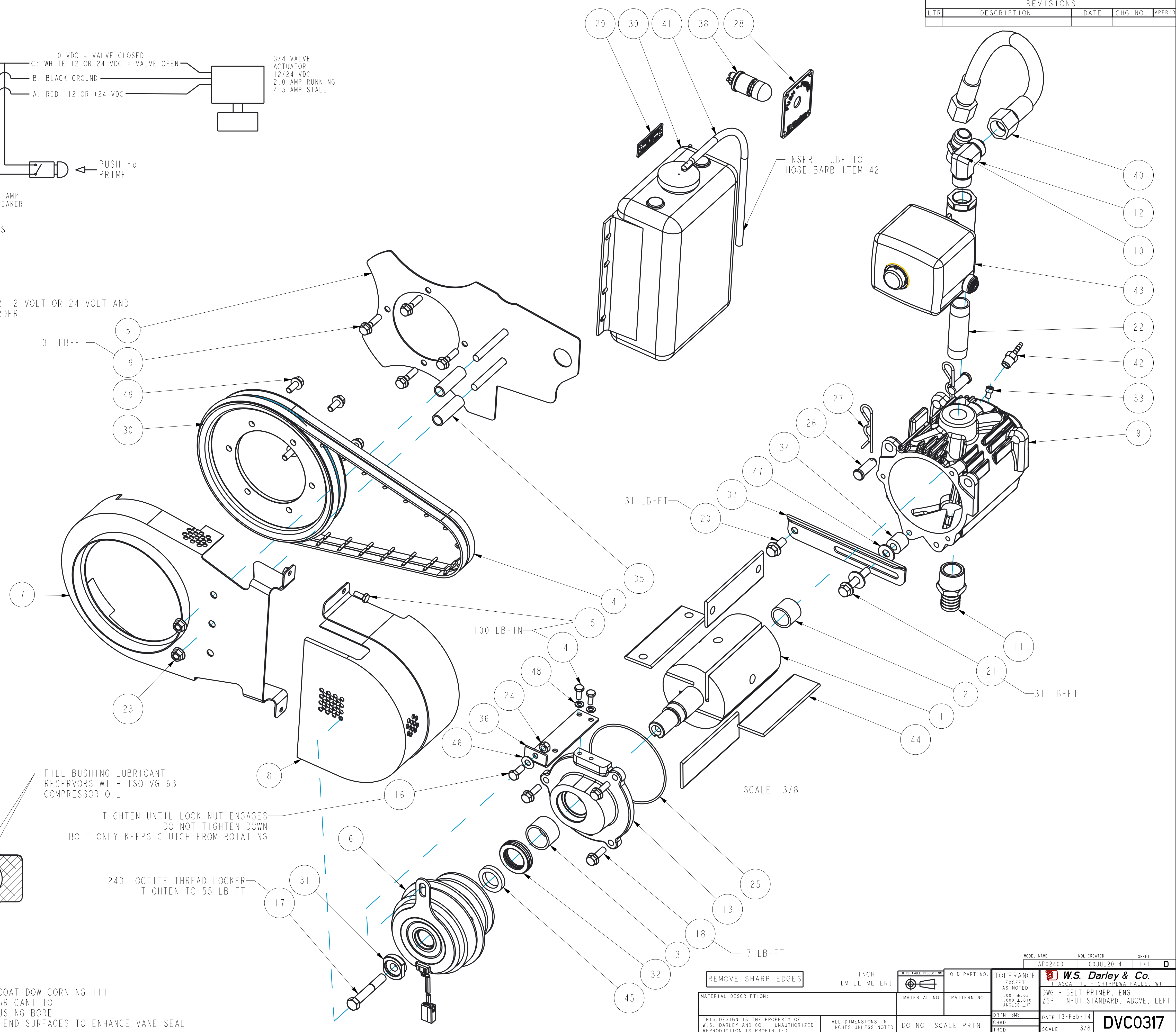

SECTION A-A  
SCALE 1/2

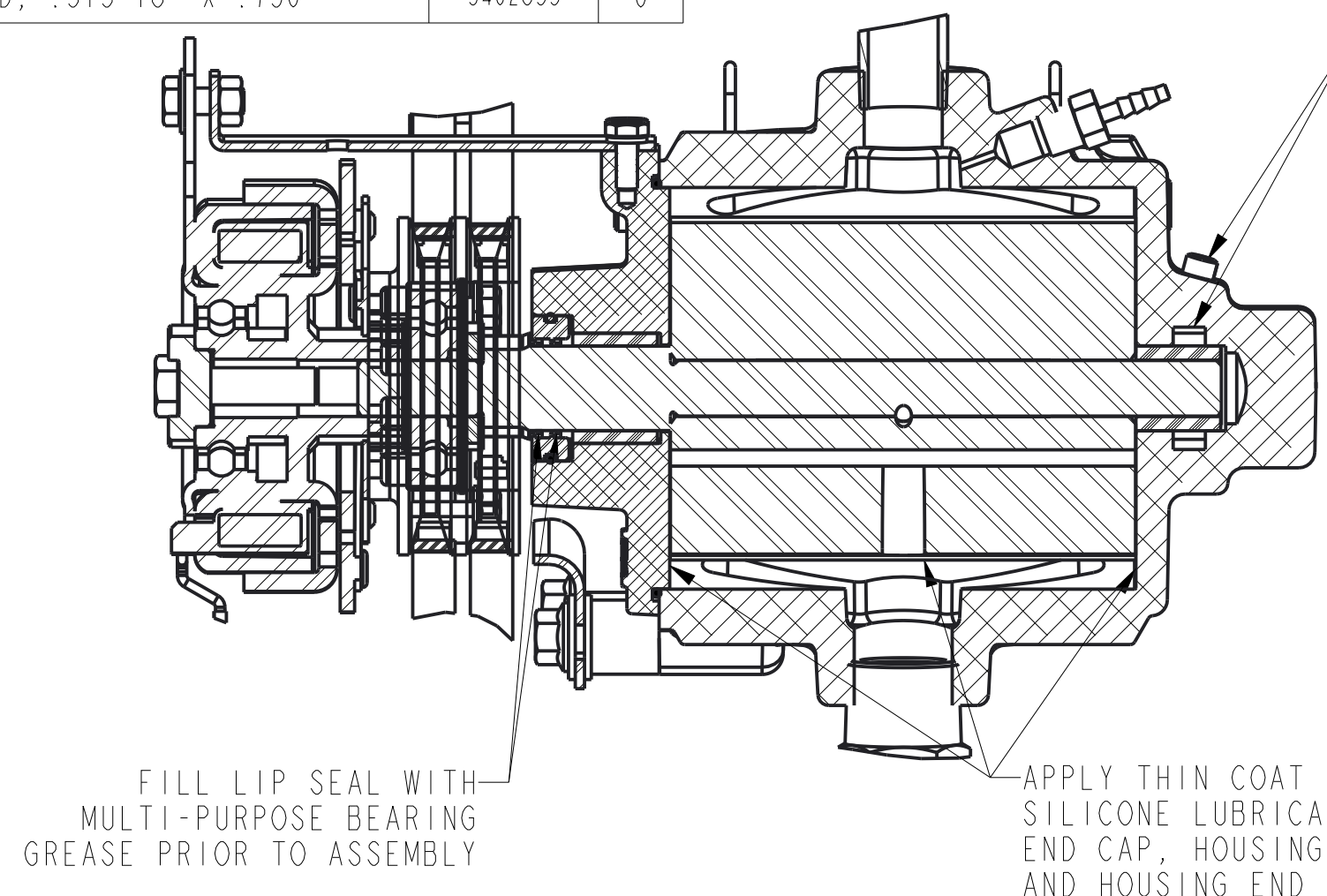

FILL BUSHING LUBRICANT RESERVOIRS WITH ISO VG 63 COMPRESSOR OIL

TIGHTEN UNTIL LOCK NUT ENGAGES DO NOT TIGHTEN DOWN BOLT ONLY KEEPS CLUTCH FROM ROTATING

243 LOCTITE THREAD LOCKER TIGHTEN TO 55 LB-FT

REVISIONS				
LTR	DESCRIPTION	DATE	CHG NO.	APPR'D

MODEL NAME: AP02400		MOL CREATED: 09 JUL 2014		SHEET: 1/1	
TOLERANCE EXCEPT AS NOTED: .00 ± .03, .000 ± .010, ANGLES ± 1°		OLD PART NO.		DWG - BELT PRIMER, ENG ZSP, INPUT STANDARD, ABOVE, LEFT	
MATERIAL DESCRIPTION:		MATERIAL NO.		PATTERN NO.	
THIS DESIGN IS THE PROPERTY OF W.S. DARLEY AND CO. UNAUTHORIZED REPRODUCTION IS PROHIBITED.		ALL DIMENSIONS IN INCHES UNLESS NOTED		DO NOT SCALE PRINT	
INCH (MILLIMETER)		SCALE: 3/8		DATE: 13-Feb-14	
DR: N. SMS		CHWD		TRCD	
W.S. Darley & Co. CHIPPewa FALLS, WI		DVC0317			



NO.	DESCRIPTION	PART NO.	QTY.
1	ASSY - ROTOR, 25 CU IN VAC PUMP	4434310	1
2	BEARING - OILITE, 1.000 ID	1760006	1
3	BEARING - OILITE, 1.250 ID	1760033	1
4	BELT - PRIMER DRIVE	4226905	2
5	BRACKET - BELT COVER	4027905	1
6	CLUTCH - VAC PUMP, 12VDC	4227001	1
7	COVER - BELT	2505405	1
8	COVER - BELT	2505406	1
9	CYLINDER - VACUUM PUMP, 25 CU IN	1021203	1
10	FITTING- .75NPTMx.75JICM	3501553	1
11	FTG - BARB, 1.00 ID X 1.00 NPT	MAB502031	1
12	FTG-.75NPTMX1 1/16-12JICM RIGD	3501638	1
13	HEAD - CYL, VAC PUMP, 25 CU IN	2813803	1
14	HHCS - .25-20 X .63, GR 5 SST	5400603	2
15	HHCS - .250-20 x 0.63, GR5	5400001	2
16	HHCS - .313-18 x 0.75, SST	5400641	1
17	HHCS - .438-20 x 2.75, GR5	5400118	1
18	HHCS - FLANGED, .313-18 X 1.00	5402843	3
19	HHCS - FLANGED, .313-18 X 1.25	5402844	4
20	HHCS - FLANGED, .375-16 X .88	5402835	1
21	HHCS - FLANGED, .375-16 X 2.00	5402871	1
22	NIPPLE - PIPE, .75 X 3.50, BR	1081042	1
23	NUT - FLANGED TOP LOCK	5403468	2
24	NUT - HEX, .313-18, NYLOC, SST	5403400	1
25	O-RING - 4.75 x 4.94 x 0.09	3601114	1
26	PIN - CLEVIS, .5"	4401501	2
27	PIN - COTTER, .125 SST HAIRPIN	3605213	2
28	PLATE - PRIMER, PUSH BUTTON	1978500	1
29	PLATE - PRIMER LUBRICANT TANK	1963400	1
30	PULLEY - PRIMER DRIVE	4822600	1
31	RETAINER - BEARING, PRIMER CLUTCH	2314400	1
32	SEAL - FURON MECHANICAL, 1.250	1843403	1
33	SHCS - .250-20 x 0.37 SST	5401400	1
34	SPACER - .406 X .88 X .800	3309001	1
35	SPACER - 0.49 x 0.68 x 2.12	3306724	2
36	STRAP - CLUTCH ANTI-ROTATION	4038110	1
37	STRAP - PRIMER SUPPORT, ZSE	4038013	1
38	SWITCH - C7H, PUSH-BTN	2600008	1
39	TANK - PRIMER, 4 QUART, W/CAP	4403703	1
40	TUBE - PRIMER CONNECT	4434801_RIGHT	1
41	TUBE - ROUND, 0.19 X 6', NEO	1101937	1
42	TUBE FITTING - STR, .25 X .19	3500021	1
43	VALVE - ACTUATED, 12/24VDC, .75NP	5200404	1
44	VANE - ROTOR, 25 CU IN, .1905 TH	4434200	4
45	WASHER - 1.00 x 1.50 x .273 SS	3603342	1
46	WASHER - FLAT, 0.31 ID, SST	3603812	1
47	WASHER - FLAT, 3/8, STEEL	3603803	2
48	WASHER - LOCK, 0.250 ID, SST	3603532	2
49	HHCS - FLANGED, .313-18 X .750	5402833	6

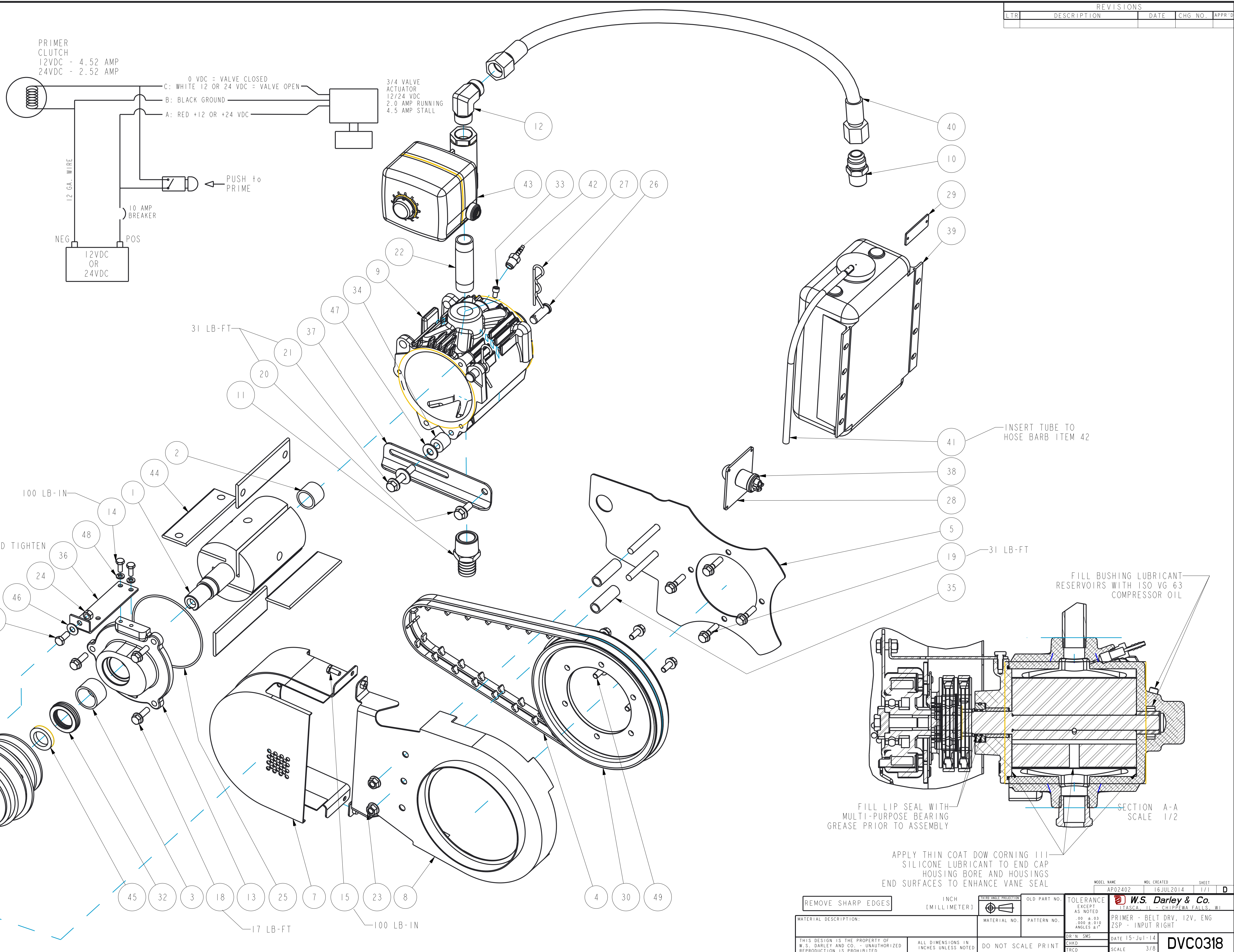

REVISIONS				
LTR	DESCRIPTION	DATE	CHG NO.	APPR'D

REMOVE SHARP EDGES		INCH (MILLIMETER)		OLD PART NO.		TOLERANCE EXCEPT AS NOTED		W.S. Darley & Co. TTASCA, IL - CHIPPEWA FALLS, WI	
MATERIAL DESCRIPTION:		MATERIAL NO.		PATTERN NO.		.00 ± .03 .000 ± .010 ANGLES ± .1°		PRIMER - BELT DRV, 12V, ENG ZSP - INPUT RIGHT	
THIS DESIGN IS THE PROPERTY OF W.S. DARLEY AND CO. - UNAUTHORIZED REPRODUCTION IS PROHIBITED		ALL DIMENSIONS IN INCHES UNLESS NOTED		DO NOT SCALE PRINT		DR: N. SMS CHWD TRCD		DATE 15-JUL-14 SCALE 3/8 DVC0318	

MODEL NAME: AP02402  
MOL CREATED: 16 JUL 2014  
SHEET: 1/1



NO.	DESCRIPTION	PART NO.	QTY.
1	ASSY - ROTOR, 25 CU IN VAC PUMP	-	1
2	BEARING - OILITE, 1.000 ID	-	1
3	BEARING - OILITE, 1.250 ID	-	1
4	BELT - PRIMER DRIVE	-	2
5	BRACKET - BELT COVER	-	1
6	CLUTCH - VAC PUMP, 24VDC	-	1
7	COVER - BELT	-	1
8	COVER - BELT	-	1
9	CYLINDER - VACUUM PUMP, 25 CU IN	-	1
10	FITTING-.75NPTx.75JICM	-	1
11	FTG - BARB, 1.00 ID X 1.00 NPT MALE	-	1
12	FTG-.75NPTMX1 1/16-12JICM RIGD	-	1
13	HEAD - CYL, VAC PUMP, 25 CU IN	-	1
14	HHCS - .25-20 X .63, GR 5 SST	-	2
15	HHCS - .250-20 x 0.63, GR5	-	2
16	HHCS - .313-18 x 0.75, SST	-	1
17	HHCS - .438-20 x 2.75, GR5	-	1
18	HHCS - FLANGED, .313-18 X 1.00	-	3
19	HHCS - FLANGED, .313-18 X 1.25	-	4
20	HHCS - FLANGED, .375-16 X .88	-	1
21	HHCS - FLANGED, .375-16 X 2.00	-	1
22	NIPPLE - PIPE, .75 X 3.50, BR	-	1
23	NUT - FLANGED TOP LOCK	-	2
24	NUT - HEX, .313-18, NYLOC, SST	-	1
25	O-RING - 4.75 x 4.94 x 0.09	-	1
26	PIN - CLEVIS, .5"	-	2
27	PIN - COTTER, .125 SST HAIRPIN	-	2
28	PLATE - PRIMER, PUSH BUTTON	-	1
29	PLATE - PRIMER LUBRICANT TANK	-	1
30	PULLEY - PRIMER DRIVE	-	1
31	RETAINER - BEARING, PRIMER CLUTCH	-	1
32	SEAL - FURON MECHANICAL, 1.250	-	1
33	SHCS - .250-20 x 0.37 SST	-	1
34	SPACER - .406 X .88 X .800	-	1
35	SPACER - 0.49 x 0.68 x 2.12	-	2
36	STRAP - CLUTCH ANTI-ROTATION	-	1
37	STRAP - PRIMER SUPPORT, ZSE	-	1
38	SWITCH - C7H, PUSH-BTN	-	1
39	TANK - PRIMER, 4 QUART, W/CAP	-	1
40	TUBE - PRIMER CONNECT	-	1
41	TUBE - ROUND, 0.19 X 6', NEO	-	1
42	TUBE FITTING - STR, .25 X .19	-	1
43	VALVE - ACTUATED, 12/24VDC, .75NPT FE	-	1
44	VANE - ROTOR, 25 CU IN, .1905 THICK	-	4
45	WASHER - 1.00 x 1.50 x .273 SS	-	1
46	WASHER - FLAT, 0.31 ID, SST	-	1
47	WASHER - FLAT, 3/8, STEEL	-	2
48	WASHER - LOCK, 0.250 ID, SST	-	2
49	HHCS - FLANGED, .313-18 X .750	-	6

NOTE:  
1) PRIMER ASSEMBLY IS EITHER 12 VOLT OR 24 VOLT AND MUST BE SPECIFIED UPON ORDER

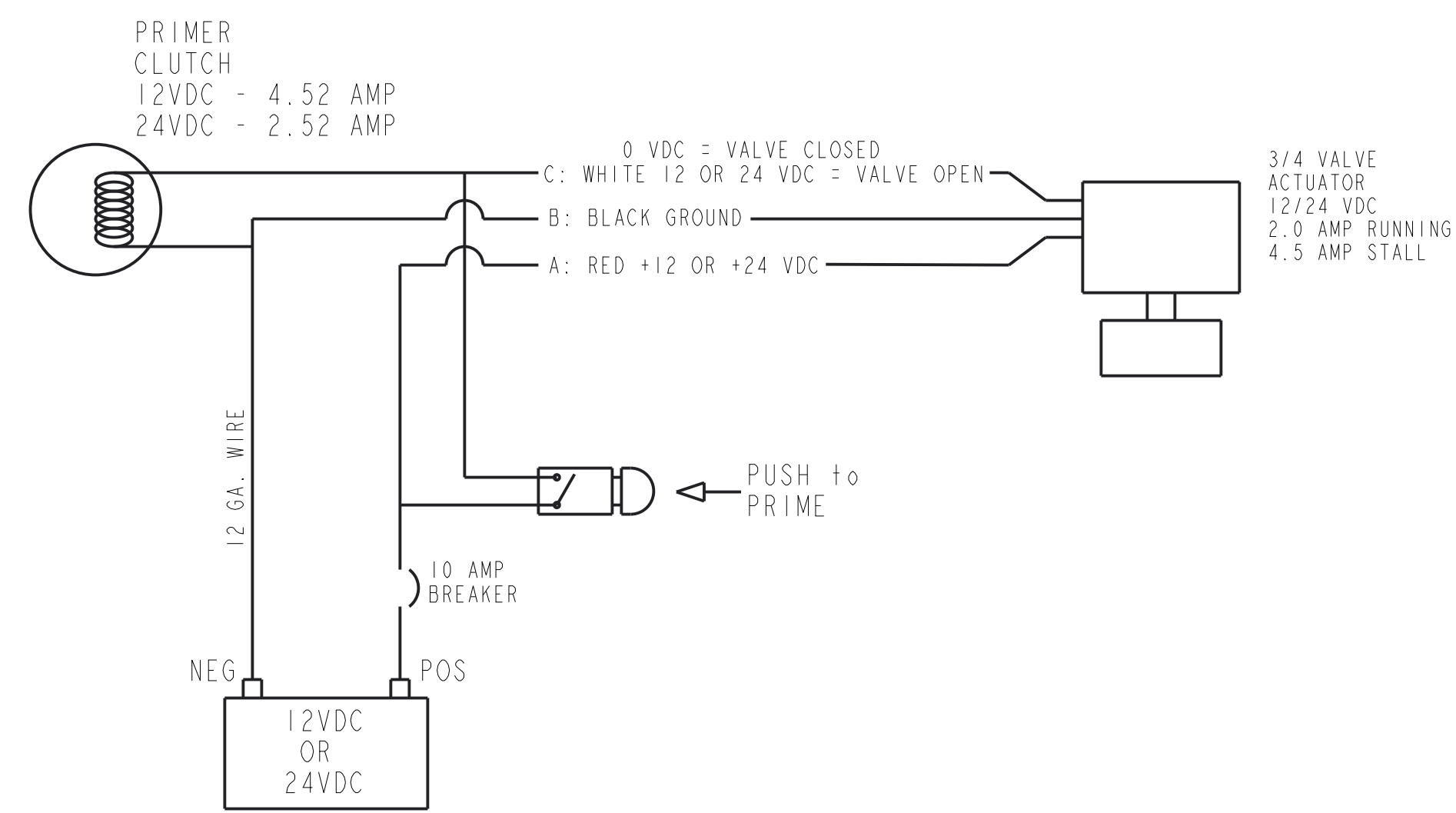

SECTION A-A  
SCALE 1/2

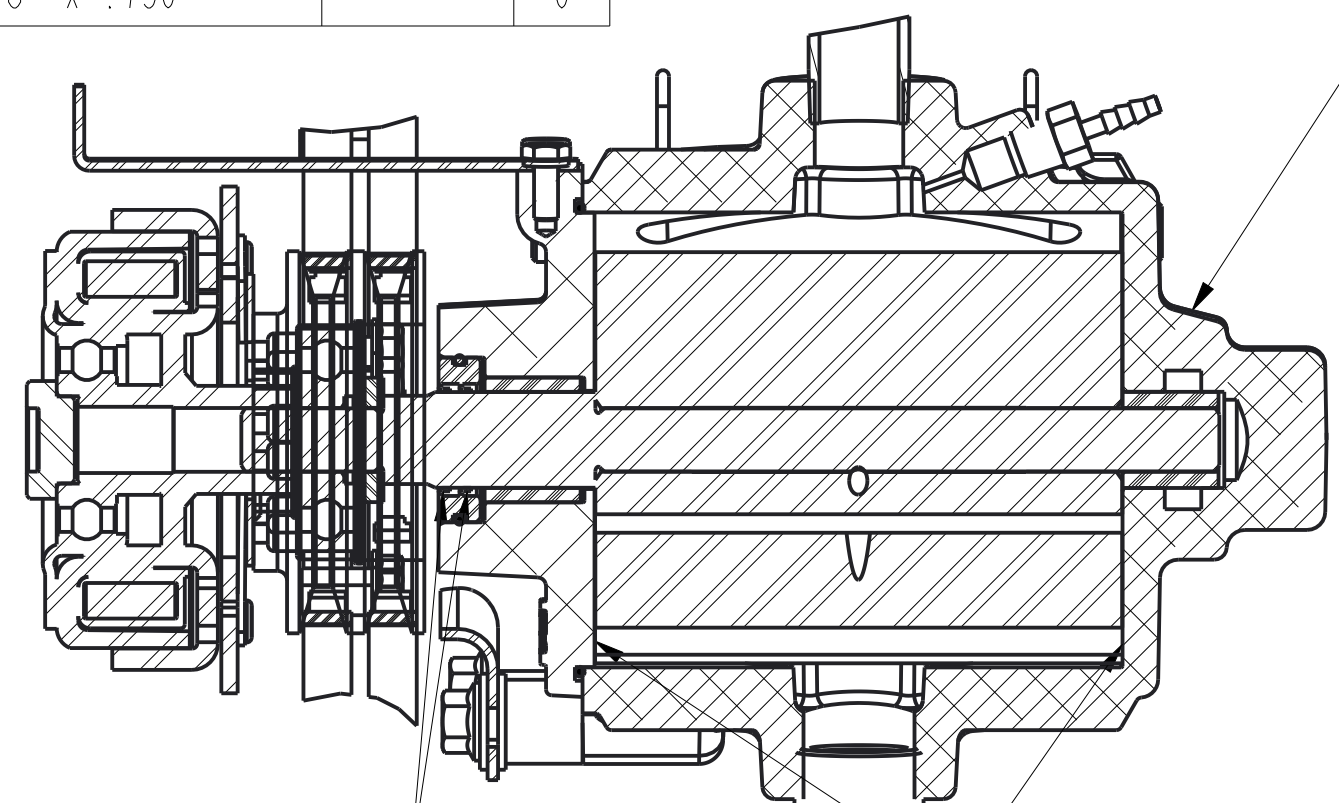

APPLY THIN COAT DOW CORNING 111 SILICONE LUBRICANT TO END CAP, HOUSING BORE AND HOUSING END SURFACES TO ENHANCE VANE SEAL

FILL BUSHING LUBRICANT RESERVOIRS WITH ISO VG 63 COMPRESSOR OIL

TIGHTEN UNTIL LOCK NUT ENGAGES DO NOT TIGHTEN DOWN BOLT ONLY KEEPS CLUTCH FROM ROTATING

243 LOCTITE THREAD LOCKER TIGHTEN TO 55 LB-FT

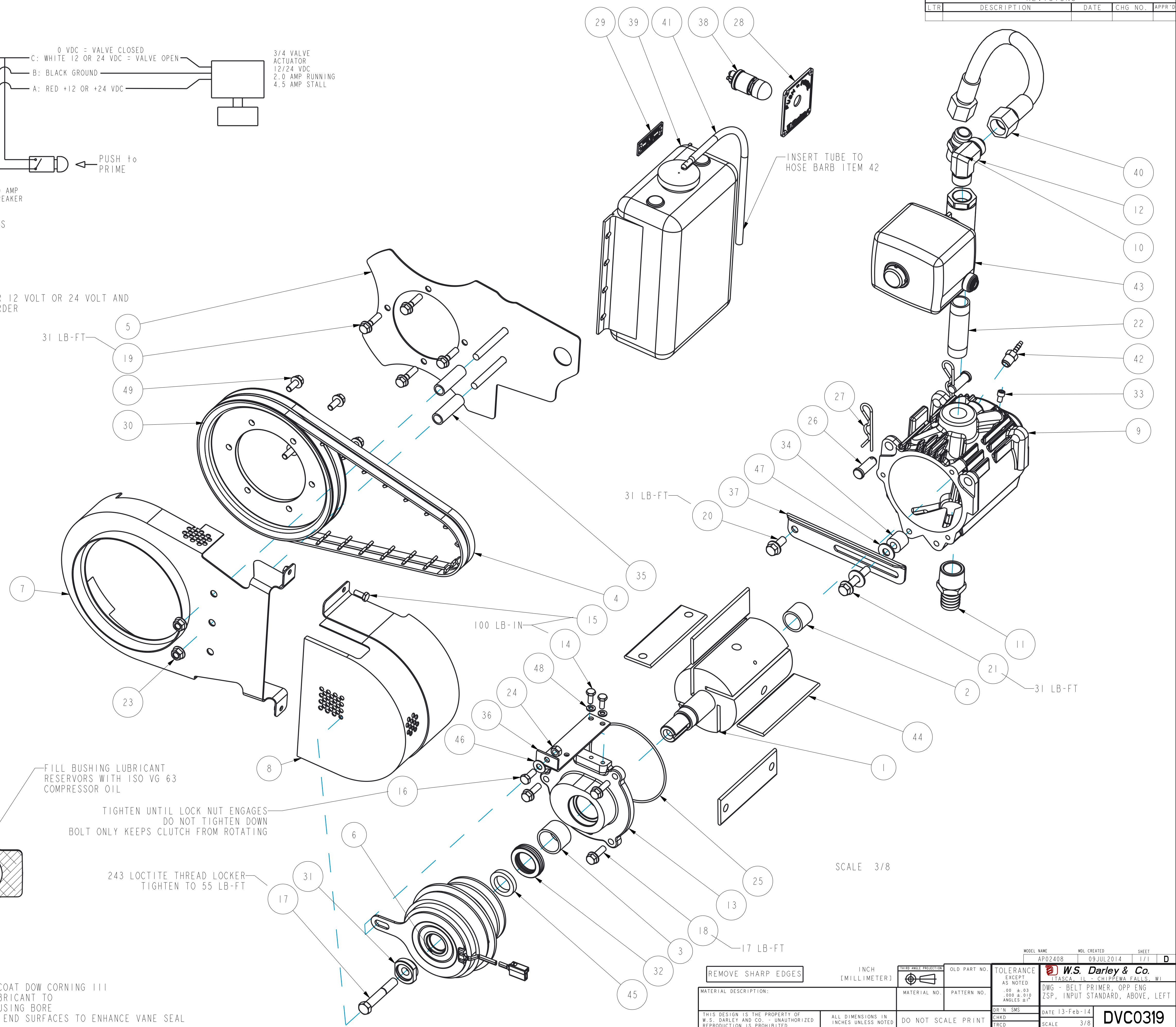

REVISIONS			
LTR	DESCRIPTION	DATE	APPR'D

MODEL NAME: AP02408		MOL CREATED: 09 JUL 2014		SHEET: 1/1	
MATERIAL DESCRIPTION:		MATERIAL NO.:		PATTERN NO.:	
TOLERANCE EXCEPT AS NOTED: .00 ± .03, .000 ± .010, ANGLES ± 1°		OLD PART NO.:		TOLERANCE EXCEPT AS NOTED: .00 ± .03, .000 ± .010, ANGLES ± 1°	
THIS DESIGN IS THE PROPERTY OF W.S. DARLEY AND CO. UNAUTHORIZED REPRODUCTION IS PROHIBITED.		DO NOT SCALE PRINT		DATE: 13-Feb-14	
ALL DIMENSIONS IN INCHES UNLESS NOTED		SCALE: 3/8		DWG - BELT PRIMER, OPP ENG ZSP, INPUT STANDARD, ABOVE, LEFT	
W.S. Darley & Co. CHWD		SCALE: 3/8		DVC0319	



NO.	DESCRIPTION	PART NO.	QTY.
1	ASSY - ROTOR, 25 CU IN VAC PUMP	4434314	1
2	BEARING - OILITE, 1.000 ID	1760006	1
3	BEARING - OILITE, 1.250 ID	1760033	1
4	BELT - PRIMER DRIVE	4226905	2
5	BRACKET - BELT COVER	4027905	1
6	CLUTCH - VAC PUMP, 12VDC	4227001	1
7	COVER - BELT	2505405	1
8	COVER - BELT	2505406	1
9	CYLINDER - VACUUM PUMP, 25 CU IN	1021202	1
10	FITTING-.75NPTMx.75JICM	3501553	1
11	FTG - BARB, 1.00 ID X 1.00 NPT	MAB502031	1
12	FTG-.75NPTMX1/16-12JICM RIGD	3501638	1
13	HEAD - CYL, VAC PUMP, 25 CU IN	2813802	1
14	HHCS - .25-20 X .63, GR 5 SST	5400603	2
15	HHCS - .250-20 x 0.63, GR5	5400001	2
16	HHCS - .313-18 x 0.75, SST	5400641	1
17	HHCS - .438-20 x 2.75, GR5	5400118	1
18	HHCS - FLANGED, .313-18 X 1.00	5402843	3
19	HHCS - FLANGED, .313-18 X 1.25	5402844	4
20	HHCS - FLANGED, .375-16 X .88	5402835	1
21	HHCS - FLANGED, .375-16 X 2.00	5402871	1
22	NIPPLE - PIPE, .75 X 3.50, BR	1081042	1
23	NUT - FLANGED TOP LOCK	5403468	2
24	NUT - HEX, .313-18, NYLOC, SST	5403400	1
25	O-RING - 4.75 x 4.94 x 0.09	3601114	1
26	PIN - CLEVIS, .5"	4401501	2
27	PIN - COTTER, .125 SST HAIRPIN	3605213	2
28	PLATE - PRIMER, PUSH BUTTON	1978500	1
29	PLATE - PRIMER LUBRICANT TANK	1963400	1
30	PULLEY - PRIMER DRIVE	4822600	1
31	RETAINER - BEARING, PRIMER CLUTCH	2314400	1
32	SEAL - FURON MECHANICAL, 1.250	1843403	1
33	SHCS - .250-20 x 0.37 SST	5401400	1
34	SPACER - .406 X .88 X .800	3309001	1
35	SPACER - 0.49 x 0.68 x 2.12	3306724	2
36	STRAP - CLUTCH ANTI-ROTATION	4038110	1
37	STRAP - PRIMER SUPPORT, ZSE	4038013	1
38	SWITCH - C7H, PUSH-BTN	2600008	1
39	TANK - PRIMER, 4 QUART, W/CAP	4403703	1
40	TUBE - PRIMER CONNECT	4434801_RIGHT	1
41	TUBE - ROUND, 0.19 X 6', NEO	1101937	1
42	TUBE FITTING - STR, .25 X .19	3500021	1
43	VALVE - ACTUATED, 12/24VDC, .75NPT	5200404	1
44	VANE - ROTOR, 25 CU IN, .1905 THICK	4434200	4
45	WASHER - 1.00 x 1.50 x .273 SS	3603342	1
46	WASHER - FLAT, 0.31 ID, SST	3603812	1
47	WASHER - FLAT, 3/8, STEEL	3603803	2
48	WASHER - LOCK, 0.250 ID, SST	3603532	2
49	HHCS - FLANGED, .313-18 X .750	5402833	6

REVISIONS				
LTR	DESCRIPTION	DATE	CHG NO.	APPR'D

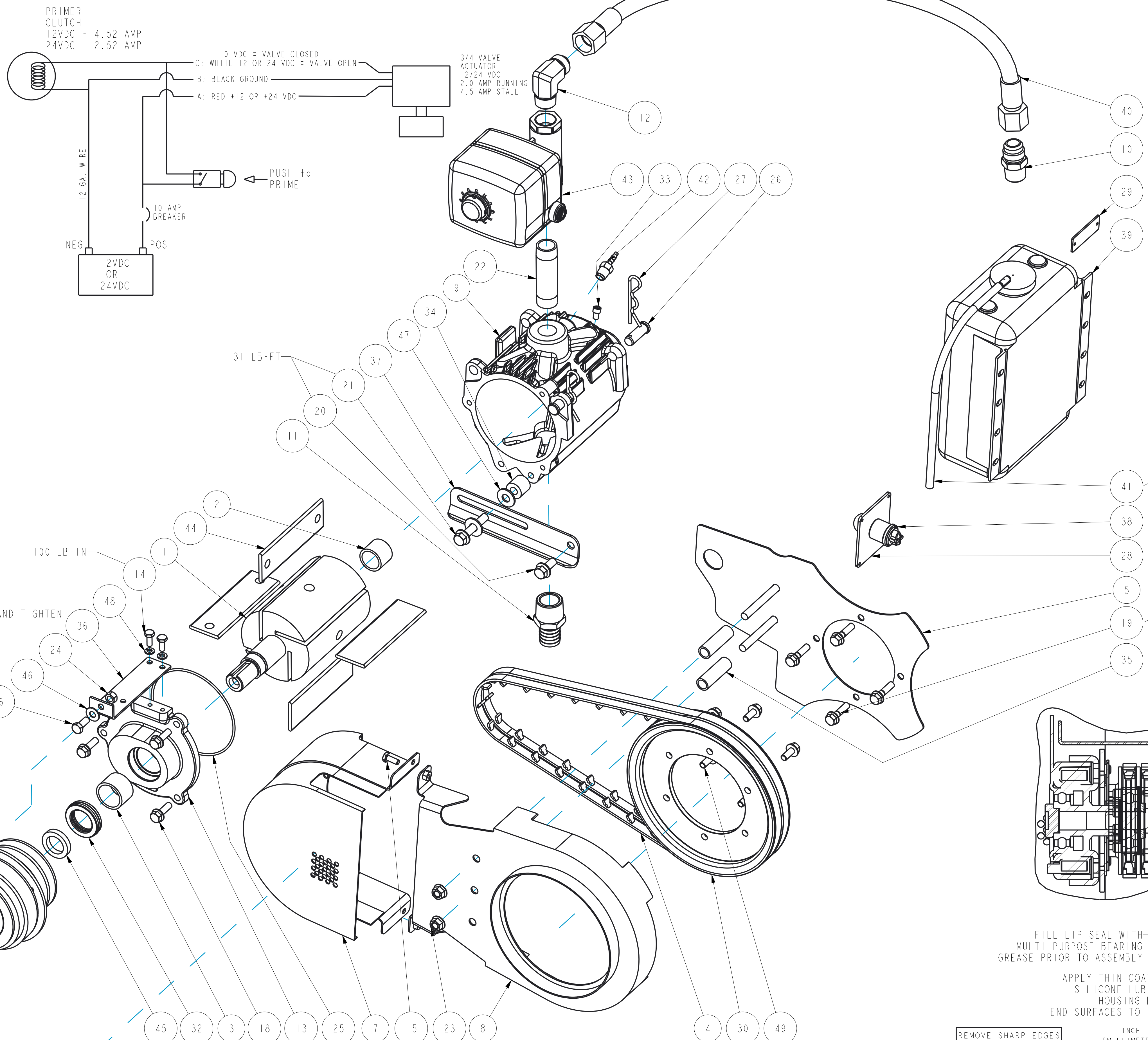

243 LOCTITE THREAD LOCKER  
TIGHTEN TO 55 LB-FT

INSERT TUBE TO  
HOSE BARB ITEM 42

FILL BUSHING LUBRICANT  
RESERVOIRS WITH ISO VG 63  
COMPRESSOR OIL

FILL LIP SEAL WITH  
MULTI-PURPOSE BEARING  
GREASE PRIOR TO ASSEMBLY

APPLY THIN COAT DOW CORNING 111  
SILICONE LUBRICANT TO END CAP  
HOUSING BORE AND HOUSINGS  
END SURFACES TO ENHANCE VANE SEAL

SECTION A-A  
SCALE 1/2

REMOVE SHARP EDGES		INCH (MILLIMETER)		OLD PART NO.		TOLERANCE EXCEPT AS NOTED		 W.S. Darley & Co. ITASCA, IL - CHIPPEWA FALLS, WI	
MATERIAL DESCRIPTION:		MATERIAL NO.		PATTERN NO.		.00 ± .03 .000 ± .010 ANGLES ± .1°		PRIMER - BELT DRV, 12V, OPP ENG ZSP - INPUT RIGHT	
THIS DESIGN IS THE PROPERTY OF W.S. DARLEY AND CO. - UNAUTHORIZED REPRODUCTION IS PROHIBITED		ALL DIMENSIONS IN INCHES UNLESS NOTED		DO NOT SCALE PRINT		DR: N. SMS CHWD TRCD		DATE 15-JUL-14 SCALE 3/8 <b>DVC0320</b>	

MODEL NAME: AP02410  
MOL CREATED: 16 JUL 2014  
SHEET: 1/1

# **Section 5**

## **Optional Equipment**

# ***MULTIPLE DRAIN VALVE***

Prepared by: RJG  
Approved by: WAH  
Revised by: WAH Via ECO 11337

Rev. A  
Date: 03/16/12  
Rev. Date: 02/19/2016  
1200643.doc

NAME:SMS OBJECT:DGC0904 DATE:13-May-10 13:22:00

NO.	DESCRIPTION	PART NO.	QTY.
1	BEARING - NYLINER, 0.50 ID	1760102	1
2	BEARING - OILITE, 0.500 ID	1760024	1
3	BODY - MULTIPLE DRAIN VALVE	5320602	1
4	BUMPER - DRAIN VALVE	4401727	9
5	CAP - MULTIPLE DRAIN VALVE	5323803	1
6	DECAL - DRAIN VALVE	1963200	1
7	GREASE ZERK - .25-28	4403200	1
8	HANDWHEEL	3001800	1
9	HHCS - .250-20 x 0.88, 18-8	5400658	2
10	NUT - HEX, .250-20, 18-8 SST	5403027	2
11	NUT - JAM, .500-20, 18-8 SST	5403219	1
12	PIN - SPRING, 0.19 X 1.00, SST	3605029	1
13	RING - RETAINER, 68011	3600435	1
14	SSS - 1/4-20 x 0.38, SST	5402603	1
15	STEM - MULTIPLE DRAIN VALVE	5241303	1

NOTE:

- 1) INSTALL JAM NUT (REF 14) WITH RED LOCTITE 262 OR EQUIVALENT
- 2) USE GREEN LOCTITE 603/609 OR EQUIVALENT WHEN PRESSING PIN (REF 16) INTO DRAIN BODY (REF 3)

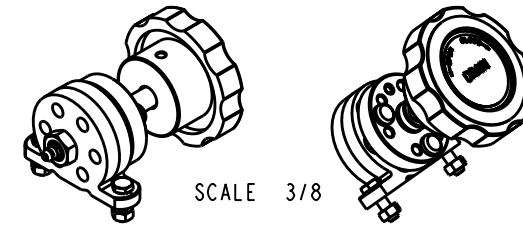
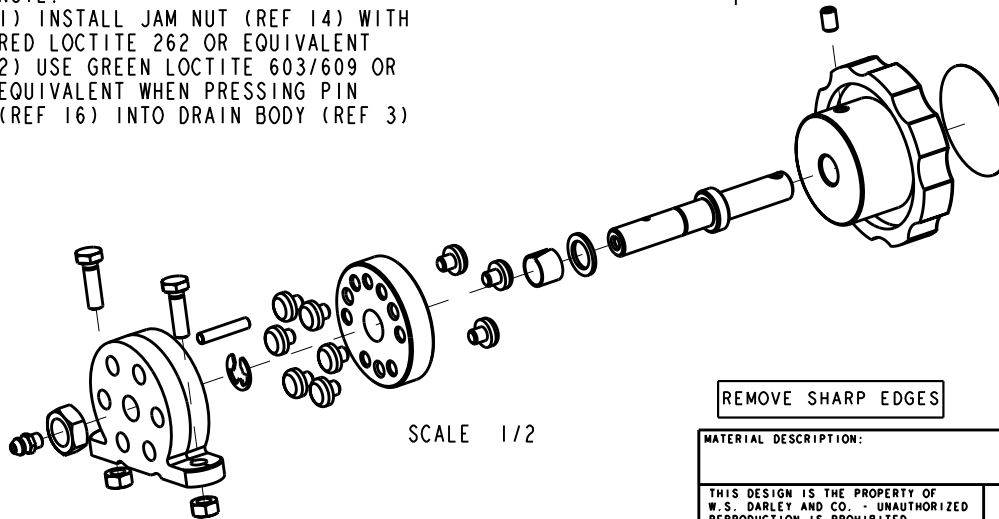
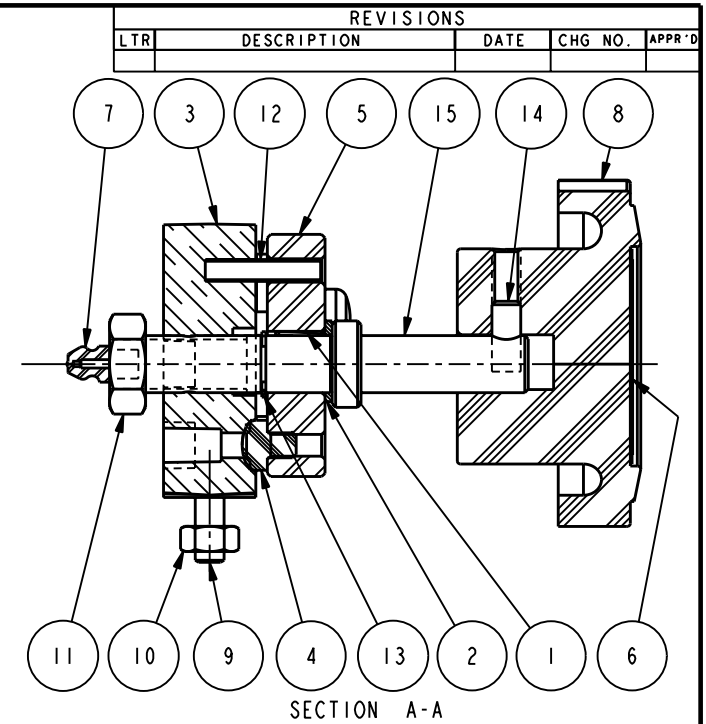
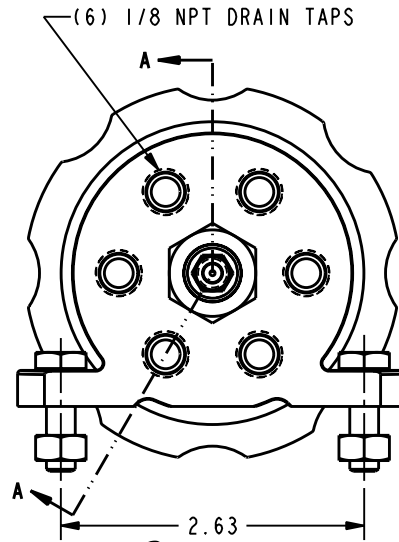

REMOVE SHARP EDGES

INCH  
(MILLIMETER)



OLD PART NO.

TOLERANCE  
EXCEPT  
AS NOTED

W.S. Darley & Co.  
ITASCA, IL - CHIPPEWA FALLS, WI

MATERIAL DESCRIPTION:

MATERIAL NO.

PATTERN NO.

.00 ± .03  
.000 ± .010  
ANGLES ± 1°

DWG - MULTIPLE DRAIN VALVE  
BUMPER

THIS DESIGN IS THE PROPERTY OF  
W.S. DARLEY AND CO. - UNAUTHORIZED  
REPRODUCTION IS PROHIBITED

ALL DIMENSIONS IN  
INCHES UNLESS NOTED

DO NOT SCALE PRINT

DR'N SMS  
CHKD MCR  
TRCD

DATE 16-Jul-09  
SCALE 1/1

**DGC0904**

REVISIONS				
LTR	DESCRIPTION	DATE	CHG NO.	APPR'D

MODEL NAME	MDL CREATED	SHEET
VD00600	12 JUN 2009	1/1 B

# ***BALL VALVE***

Prepared by: RJG  
Approved by: WAH  
Revised by: WAH Via ECO 11337

Rev. A  
Date: 03/16/12  
Rev. Date: 02/19/2016  
1200643.doc

## **BALL VALVE QUARTER TURN - SELF LOCKING**

The Darley Ball Valve is a quarter turn, all bronze valve designed for the fire service.

The ball is cast bronze, precision machined *stainless steel ball* for long trouble free service. It is easily serviced in the field.

The lever is self locking and easily adjusted, even under extreme high pressure.

### **TO DISASSEMBLE AND REPAIR THE BALL VALVE ILLUSTRATION DGC0100**

#### **TOOLS REQUIRED:**

- 3/16" Allen Wrench
- 1-1/8" Wrench
- 3/4" & 1" Wrench
- Vise Grips or Pliers

1. Remove cap nut (20) and adjusting nut (16).
2. Lever Assembly (11) pulls straight up. Watch for 2 cam balls (12).
3. Unbolt and remove clutch ring (9), clutch sleeve (8), valve stem (7), spring (14), and valve stem washer (15). Check clutch ring (9) and sleeve (8) for scoring or excessive wear. Check o-ring (26). Replace if necessary.
4. Remove nipple (2). Check Quad Ring (25). Replace if necessary.
5. Unscrew ball guide screw (6). Check o-ring (23). Replace if necessary.
6. Remove valve ball (3). Check for scratches, corrosion, and wear. Replace if necessary.
7. Remove seat assembly (4). Check condition of rubber seat. Replace seat assembly if necessary.

### **REASSEMBLY OF BALL VALVE ILLUSTRATION DGC0100**

1. Position ball (3) in body so ball guide screw (6) engages bottom of ball as it is screwed into position.
2. Put valve stem (7) into position. Make certain stem engages slot on top of ball.
3. Slip washer (15), spring (14), and clutch sleeve (8) over the stem. Place clutch ring (9) over the sleeve and secure with the four (4) 1/4" NC x 5/8" socket head cap screws.
4. Set the two cam balls (12) into the V grooves in the clutch sleeve (8) and drop lever assembly over them. Tighten the adjusting nut (16) so that approximately 1/8" play is left at the end of a 6" lever. Over tightening this nut will make the clutch lock inoperative. Lock adjusting nut (16) with cap nut (20). Recheck this adjustment after valve is placed in service.
5. Place seat assembly (4), seat o-ring (5), and quad ring (25) into position.
6. Secure nipple (2) to valve body with eight (8) 1/4" NC x 5/8" socket head cap screws.

**If more information is needed, call W.S. DARLEY & CO. at  
Chippewa Falls, WI at 800-634-7812 or 715-726-2650**

REP. NO.	NAME OF PART	QTY.
1	DISCHARGE VALVE BODY	1
2	VALVE NIPPLE	1
3	VALVE BALL	1
4	VALVE SEAT	1
5	O'RING	1
6	BALL GUIDE SCREW	1
7	VALVE STEM	1
8	CLUTCH SLEEVE	1
9	CLUTCH RING	1
10	LEVER CAM	1
11	FRONT MOUNT LEVER	1
12	CAM BALL	2
13	VALVE PIN	2
14	VALVE SPRING	1
15	VALVE STEM WASHER	1
16	ADJUSTING NUT	1
17	SPRING PIN-STL (A)	1
19	CONTROL LEVER BALL	1
20	CAP NUT	1
23	O'RING	1
25	QUAD RING	1
26	O'RING	1
27	O'RING	1
28	SOCKET HEAD CAP SCREW	4
29	SOCKET HEAD CAP SCREW	8

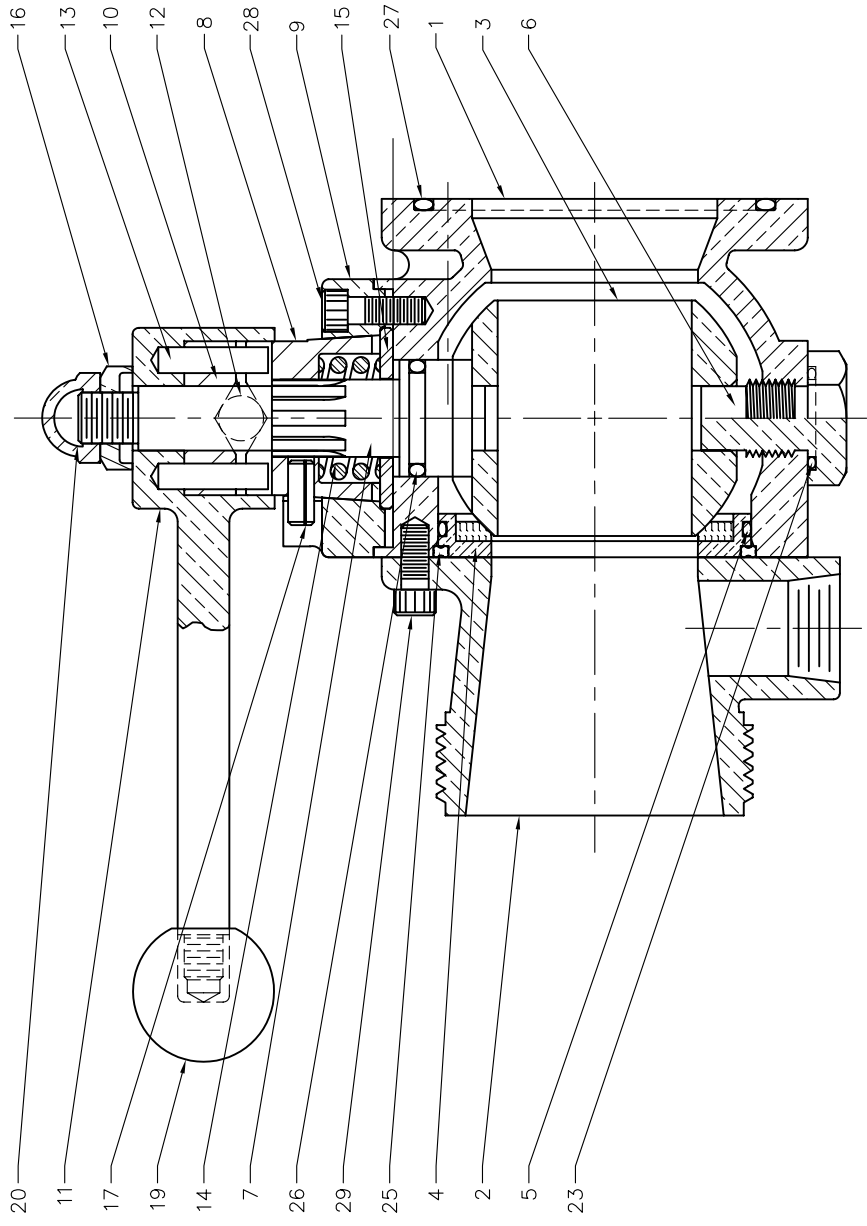

INCH [MILLIMETER] THIRD ANGLE PROJECTION

**W.S. DARLEY & Co.**  
 MELROSE PARK, ILL. - CHIPPEWA FALLS, WI

DWG. - BALL VALVE ASSEMBLY  
 CROSS SECTION

DATE NOV12,95  
 SCALE 1/1

**DGC0100**

TOLERANCE EXCEPT AS NOTED  
 .005 ±.010  
 .000 ±.010  
 ANGLES 3:1

DRN JCM  
 CHK NOV12,95  
 TRCDLMH 5/96

OLD PART NO. G1200

DO NOT SCALE PRINT

ALL DIMENSIONS IN INCHES UNLESS NOTED

THIS DESIGN IS THE PROPERTY OF W.S. DARLEY & CO. UNAUTHORIZED REPRODUCTION IS PROHIBITED

# ***PRESSURE RELIEF VALVE***

Prepared by: RJG  
Approved by: WAH  
Revised by: WAH Via ECO 11337

Rev. A  
Date: 03/16/12  
Rev. Date: 02/19/2016  
1200643.doc



# W.S. DARLEY & CO.

## REMOTE CONTROL PRESSURE RELIEF VALVE WITH MECHANICAL SHUTOFF

### Refer to Drawing DGC0141

The relief valve bypasses water from the pump discharge manifold to the suction chamber at a set pump pressure, preventing excessive rise of discharge pressure when hose lines are shut off.

Turning pressure setting hand wheel (14) clockwise raises the relief pressure, and counter clockwise lowers it.

The self-cleaning fine mesh strainer will prevent the entry of solids that could cause the relief valve to malfunction. Open the strainer flush valve to remove small accumulations. This is accomplished by turning the strainer flush valve knob (6) counter clockwise 2 to 3 full turns. Strainer trapped debris will be flushed to the ground. Pump supply pressure should be 50-100 PSI when performing this procedure.

### TO SET RELIEF VALVE

1. Turn four-way valve OFF.
2. Open at least one discharge valve and increase engine throttle setting until pressure gage indicates the pressure at which relief valve is to open.
3. Turn four-way valve ON.
4. If gage reading drops below pressure set in step 2, turn hand wheel (14) clockwise until pressure returns to set point.
5. If gage reading does not drop, turn hand wheel (14) counter clockwise until pressure drops 5 to 10 PSI below set point. Then slowly turn hand wheel clockwise until pressure returns to pressure set in step 2.

The relief valve will now prevent the discharge pressure from rising above that for which it is set, and requires no further attention.

Should a higher or lower relief pressure be desired, repeat above procedure.

### CAUTION

With all discharge valves closed, water in the auxiliary pump casing will heat up rapidly. To avoid possible damage, allow a very small stream of water to discharge when the pump is running.

**REMOTE CONTROL PRESSURE RELIEF VALVE WITH MECHANICAL SHUTOFF**  
**MAINTENANCE**  
**DRAWING DGC0141**

Open the relief valve strainer flush valve (6) during every operation at 50-100 PSI supply pressure to insure foreign material is not blocking the screen.

The 3/32" diameter metering orifice and diaphragm chamber at (21) may be back-flushed if necessary while the pump is delivering water by opening the pilot head drain and placing valve handle (9) midway between ON and OFF position.

The relief valve, pilot unit, and strainer assemblies should be taken apart for inspection and cleaning at least annually, or as often as found necessary to insure trouble free performance.

To disassemble pilot head, first turn hand wheel (14) counter clockwise to remove spring compression. Remove the four 1/4" screws holding regulator spring housing (18). Lift out diaphragm (23) and pilot valve (51) assembly. Clean and make certain 3/32" diameter orifice hole is free of obstruction.

When reassembling pilot head, turn hand wheel (14) a few times clockwise to compress spring before tightening four screws holding spring housing. This will properly center valve seat and diaphragm.

The valve piston (40) and spring (44) chamber should be inspected and cleaned.

Replace diaphragm and o-rings if damaged or deteriorated.

Apply a thin coating of waterproof grease lubricant: to spring housing counterbore that guides the pilot valve (51) and ball (52), to end of tension screw (17), and between piston (40) and center post.

Self-cleaning strainer (63) can be removed for inspection or replacement by alternately turning valve knob (6) and stop nut (7) counter clockwise until stem is free for removal. To avoid discharging water through opening created by stem (62) removal, pump should be completely shut down before stem (62) is removed. Inspect and clean screen (63) if required. Check quad ring (64) for damage or deterioration. Reverse procedure to reassemble valve. Use care when initially inserting screen into body to avoid damaging quad ring (64) or valve seat.

To replace flush valve seat (69), remove stem/screen assembly, disconnect tubing lines attached to (61) body half and unscrew (61) body half from (70) body half. Replace (69) valve seat. Reverse procedure to reassemble valve.

All Darley relief valves can be provided with a micro switch and either one or two pilot lights to indicate when the valve is open or closed.

**IF FURTHER INFORMATION IS NEEDED, CALL W.S. DARLEY & CO. AT**  
**CHIPPEWA FALLS, WI. AT 800-634-7812 or 715-726-2650**

REVISIONS		DATE	CHG. NO.	APPROV.
LTR	DESCRIPTION			
A	REVERSED LIGHT POSITIONS	12JUL07	2007-285	RAG
B	ADDED FLOW PATH VIEW	21NOV2007	2007-451	SMS

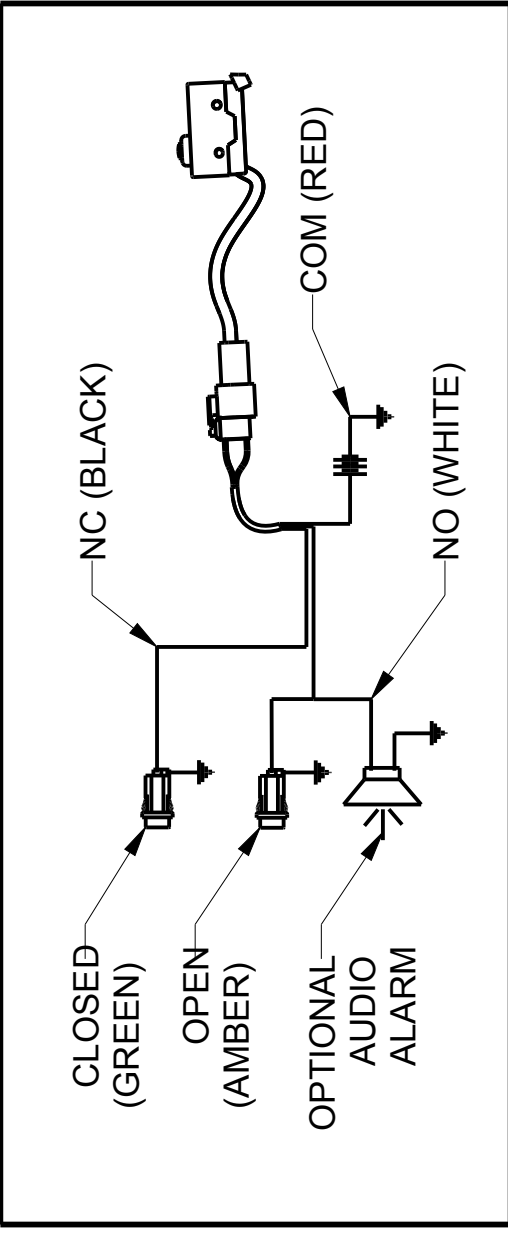
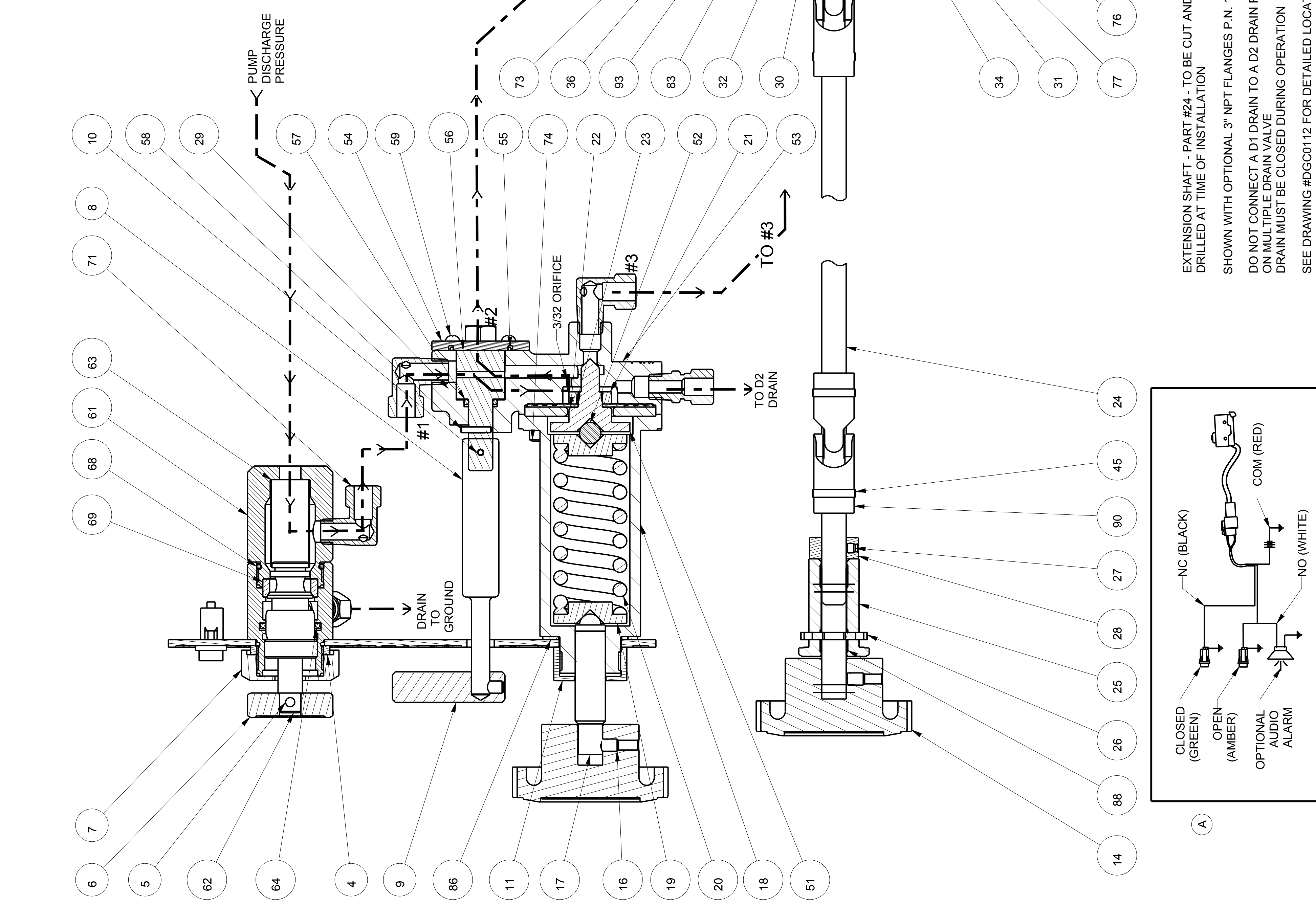
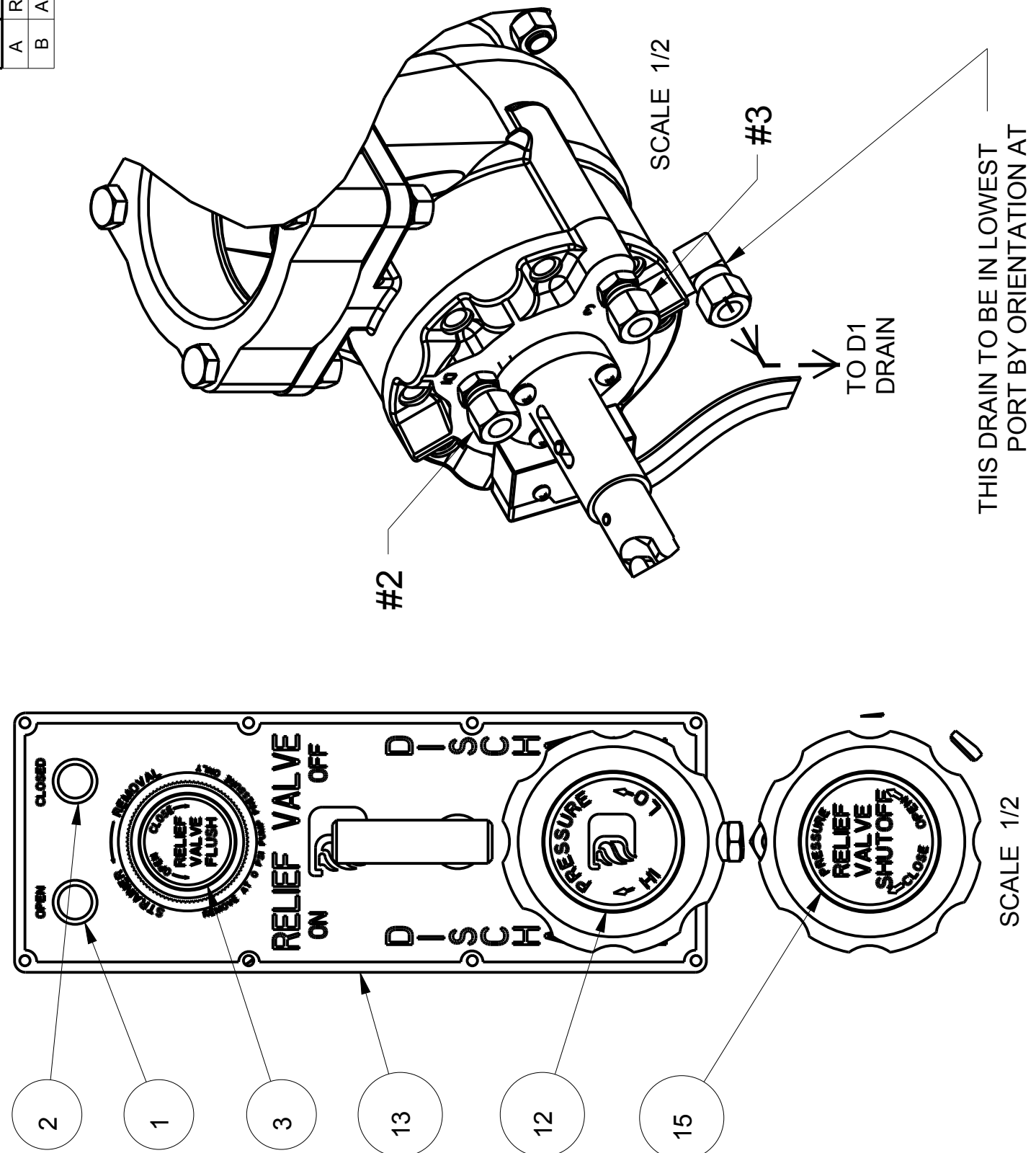
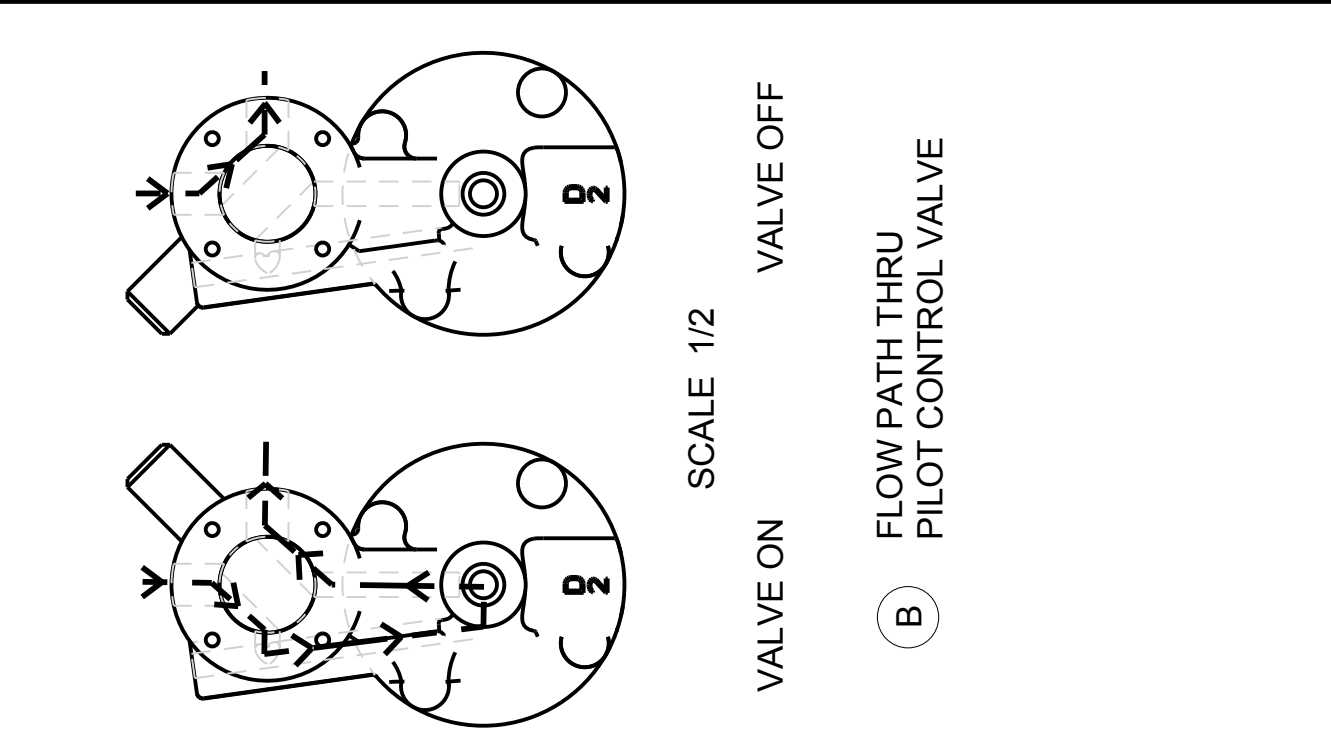

EXTENSION SHAFT - PART #24 - TO BE CUT AND DRILLED AT TIME OF INSTALLATION  
 SHOWN WITH OPTIONAL 3" NPT FLANGES P.N. 1920503  
 DO NOT CONNECT A D1 DRAIN TO A D2 DRAIN PORT ON MULTIPLE DRAIN VALVE  
 DRAIN MUST BE CLOSED DURING OPERATION  
 SEE DRAWING #DGC0112 FOR DETAILED LOCATION

NO.	DESCRIPTION	PART NO.	QTY.
1	LIGHT - AMBER		1
2	LIGHT - GREEN		1
3	DECAL - FLUSH SCREEN		1
4	NUT - PANEL FLUSH VALVE		1
5	SSS - NO 10-32 x 0.38 GR5		1
6	KNOB - FLUSH VALVE		1
7	NUT - PANEL 1.38-12		1
8	COUPLING - RELIEF VALVE STEM		1
9	LEVER - R.V. ON/OFF		1
10	PN - DRIVE LOK 0.125 X 0.750		1
11	NUT - PANEL VALVE 1.250-12		1
12	DECAL - PRESSURE HI/LO		1
13	PLATE - TRIM REMOTE HEAD		1
14	HANDWHEEL		2
15	DECAL - PRESSURE RELIEF VALVE		1
16	SSS - 1/4-20 x 0.38 SST		3
17	SCREW - SPRING TENSION		1
18	HOUSING - PILOT VALVE		1
19	RETAINER - SPRING		2
20	SPRING - PRESSURE REGULATOR		1
21	NUT - PILOT VALVE		1
22	RING - HOUSING PILOT		1
23	DINPHRAM - PILOT HEAD		1
24	SHAFT - R.V. EXTENSION 24"		1
25	BUSHING - RETAINER PANEL		1
26	NUT - .750 CONDUIT		1
27	SSS - NO 10-24 x 0.19 GR5		1
28	COLLAR - SHAFT 1/2" BORE		1
29	SSS - 3/16 x 0.31 GR5		1
30	COUPLING - RELIEF VALVE STEM		1
31	MICROSWITCH - OMRON		1
32	PN - SPRING 0.19 X 1.12		1
33	O-RING - 0.38 x 0.50 x 0.06		2
34	O-RING - 0.44 x 0.62 x 0.09		1
35	O-RING - 0.75 x 0.94 x 0.09		1
36	PLATE - SEAL VALVE STEM		1
37	O-RING - 3.25 x 3.38 x 0.06		1
38	HEAD - RELIEF VALVE REMOTE 3"		1
39	STEM - RELIEF VALVE 3"		1
40	PISTON - RELIEF VALVE 3"		1
41	BODY - RELIEF VALVE 3"		1
42	O-RING - 3.50 x 3.89 x 0.09		2
43	CENTER PLUG - PISTON SPRING		1
44	SPRING - PISTON		1
45	PN - SPRING 0.16 X 0.88		4
46	QUAD RING - 2.88 x 3.25 x 0.19		1
47	WASHER - 0.39 x 0.61 x 0.06 BR		1
48	STEM - RELIEF VALVE SWITCH		1
49	SHIM - SWITCH SPACER 0.0125		1
50	PLUG - PIPE 0.125 SST SOC HD		1
51	PN - PILOT VALVE		1
52	BALL - CAM 0.04"		1
53	HEAD - PILOT CONTROL		1
54	COVER - ON/OFF VALVE		1
55	O-RING - 1.12 x 1.25 x 0.06		1
56	PLUG - VALVE		1
57	O-RING - 0.50 x 0.69 x 0.09		1
58	PN - SPRING 0.12 X 0.62 SST		1
59	RHMS - NO 8-32 X 0.50 BR		4
60	BODY - FLUSH VALVE COMPLETE		1
61	STEM - FLUSH VALVE		1
62	STRAINER - SCREEN		1
63	QUAD RING - 1.00 x 1.25 x 0.12		1
64	O-RING - 1.19 x 1.38 x 0.09		1
65	SEAT - FLUSH VALVE		1
66	TUBE FITTING - EL. 3/8 x 25		5
67	TUBE FITTING - STR. 3/8 d x 25 NPTM		3
68	TUBE FITTING - STR. 3/8 d x 1.12 NPTM		1
69	SHCS - 250-20 x 0.88 SST		4
70	SHCS - 315-19 x 0.75 GR8		8
71	WASHER - LOCK NO 8 ID SST		2
72	RHMS - NO 6-32 X 1.00 BR		2
73	NUT - HEX .375-16 GR2		8
74	HHCS - 375-16 x 2.25 GR5		8
75	FLANGE - ADAPTER 3 NPT		2
76	RHMS - NO 10-24 X 0.75 GR5		3
77	WASHER - INT TOOTH 1.250 ID		1
78	BEARING - IN-LINER 0.50 ID		2
79	JOINT UNIVERSAL 500"		1
80	SHIM - SWITCH SPACER 0.025		2
81	WASHER - LOCK NO 10 ID SST		1
82	CONNECTOR - DUETCH DT 06-S		1

REV. NO.	DESCRIPTION	DATE	CHG. NO.	APPRO.
LTR				

SHOWN WITH OPTIONAL 3" NPT FLANGES - P.N. 1920503  
 EXTENSION SHAFT - ITEM #24 - TO BE CUT AND  
 DRILLED AT TIME OF INSTALLATION  
 DO NOT CONNECT A D1 DRAIN TO A D2 DRAIN PORT  
 ON MULTIPLE DRAIN VALVE  
 DRAIN MUST BE CLOSED DURING OPERATION  
 SEE DRAWING #DGC0112 FOR DETAILED LOCATION  
 SEE SHEET #1 FOR WIRING SCHEMATIC

NO.	DESCRIPTION	PART NO.	QTY.
1	LIGHT - AMBER		1
2	LIGHT - GREEN		1
3	DECAL - FLUSH SCREEN		1
4	NUT - PANEL FLUSH VALVE		1
5	SSS - NO. 10-32 X 0.38, GR5		1
6	KNOB - FLUSH VALVE		1
7	NUT - PANEL, 1.38-12		1
8	COUPLING - RELIEF VALVE STEM		1
9	LEVER - R.V. ON/OFF		1
10	PN - DRIVE LOK, 0.125 X 0.750		1
11	NUT - PANEL VALVE, 1.250-12		1
12	DECAL - PRESSURE, HILO		1
13	PLATE - TRIM, REMOTE HEAD		1
14	HANDWHEEL		2
15	DECAL - PRESSURE RELIEF VALVE		1
16	SSS - 1/4-20 X 0.38, SST		3
17	SCREW - SPRING TENSION		1
18	HOUSING - PILOT VALVE		1
19	RETAINER - SPRING		2
20	SPRING - PRESSURE REGULATOR		1
21	NUT - PILOT VALVE		1
22	RING - HOUSING PILOT		1
23	DIAPHRAGM - PILOT HEAD		1
24	SHAFT - R.V. EXTENSION, 24"		1
25	BUSHING - RETAINER PANEL		1
26	NUT - .750, CONDUIT		1
27	SSS - NO. 10-24 X 0.19, GR5		1
28	COLLAR - SHAFT, 1/2" BORE		1
29	SSS - .313 X 0.31, GR5		1
30	COUPLING - RELIEF VALVE STEM		1
31	MICROSWITCH - OMRON		1
32	PN - SPRING, 0.19 X 1.12		1
33	O-RING - 0.38 X 0.50 X 0.06		2
34	O-RING - 0.44 X 0.62 X 0.09		1
35	O-RING - 0.75 X 0.94 X 0.09		1
36	PLATE - SEAL VALVE STEM		1
37	O-RING - 3.25 X 3.38 X 0.06		1
38	HEAD - RELIEF VALVE, REMOTE, 3"		1
39	STEM - RELIEF VALVE, 3"		1
40	PISTON - RELIEF VALVE, 3"		1
41	BODY - RELIEF VALVE, 3"		2
42	O-RING - 3.50 X 3.89 X 0.09		1
43	CENTER PLUG - PISTON SPRING		1
44	SPRING - PISTON		1
45	PN - SPRING, 0.16 X 0.88		1
46	QUAD RING - 2.88 X 3.25 X 0.19		4
47	WASHER - 0.39 X 0.61 X .06, BR		1
48	STEM - RELIEF VALVE SWITCH		1
49	SHIM - SWITCH SPACER, 0.0125		1
50	PLUG - PIPE, 0.125, SST, SOC HD		1
51	PN - PILOT VALVE		1
52	BALL - CAM, 0.44"		1
53	HEAD - PILOT CONTROL		1
54	COVER - ON/OFF VALVE		1
55	O-RING - 1.12 X 1.25 X 0.06		1
56	PLUG - VALVE		1
57	O-RING - 0.50 X 0.69 X 0.09		1
58	PN - SPRING, 0.12 X 0.62, SST		1
59	RHMS - NO. 8-32 X 0.50, BR		4
60	BODY - FLUSH VALVE COMPLETE		1
61	STEM - FLUSH VALVE		1
62	STRAINER - SCREEN		1
63	QUAD RING - 1.00 X 1.25 X 0.12		1
64	O-RING - 1.19 X 1.38 X 0.09		1
65	TUBE FITTING - EL., .38 X .25		5
66	TUBE FITTING - STR., .38 CI X .25 NPTM		3
67	TUBE FITTING - STR., .38 CI X .12 NPTM		1
68	SHCS - 250-20 X 0.88, SST		4
69	SHCS - 315-18 X 0.75, GR8		8
70	WASHER - LOCK, NO. 6 ID, SST		2
71	RHMS - NO. 6-32 X 1.00, BR		2
72	NUT - HEX, .375-16, GR2		8
73	HHCS - .375-16 X 2.25, GR5		8
74	FLANGE - ADAPTER, 3 NPT		2
75	RHMS - NO. 10-24 X 0.75, GR5		3
76	WASHER - INT. TOOTH, 1.250 ID		2
77	BEARING - MYLINER, 0.50 ID		2
78	JOINT - UNIVERSAL, 500"		1
79	SHIM - SWITCH SPACER, 0.025		2
80	WASHER - LOCK, NO. 10 ID, SST		3
81	CONNECTOR - DIETCH DT-06-SS		1

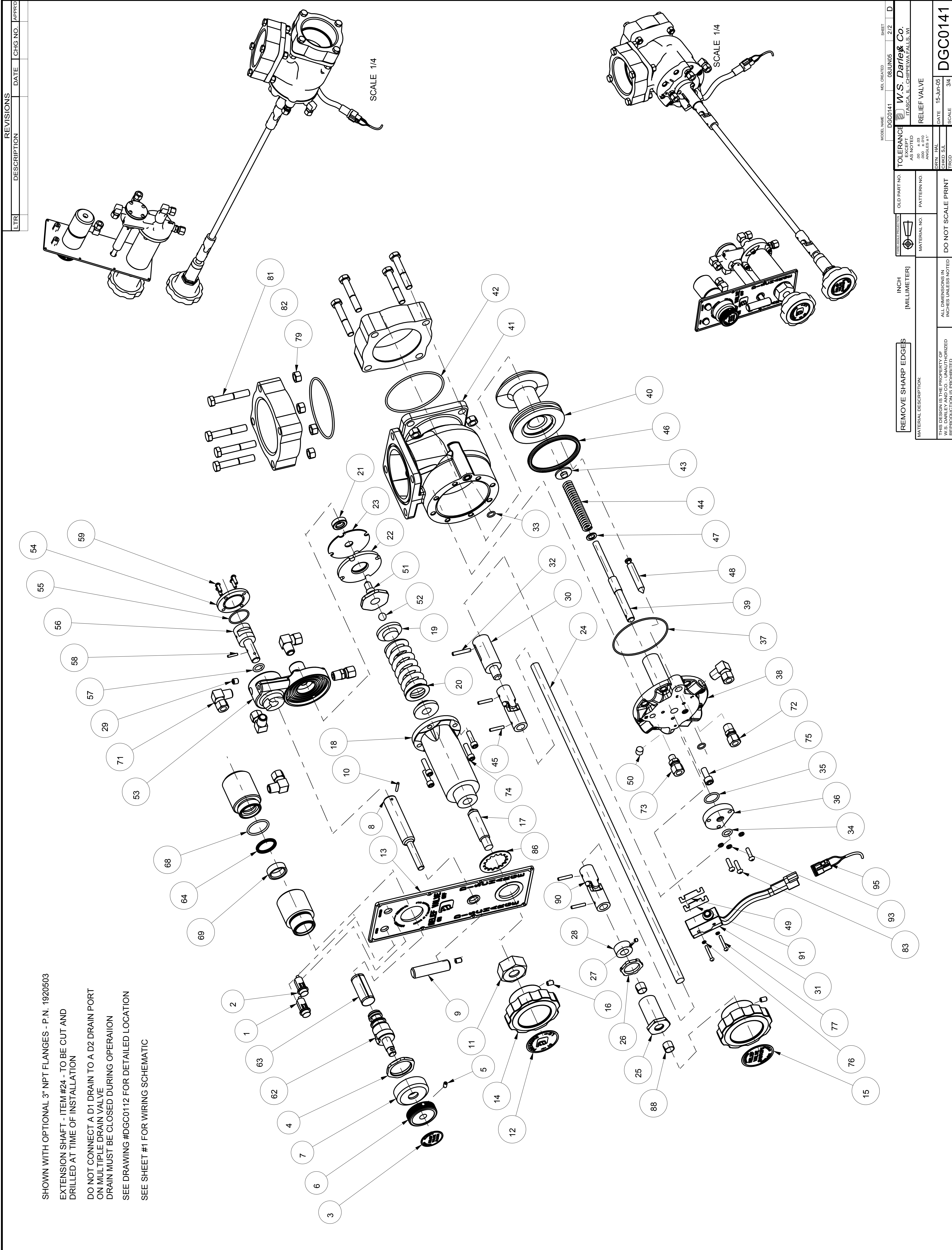

MODEL NAME	DGC01141	REV. NO.	08JUN05	SHEET	22	D
W.S. Darley & Co.	ITASCAL, IL - CHIPPewa FALLS, WI	TOLERANCE	AS NOTED			
		ANGLES	UNLESS NOTED			
		BRN. HAL.	UNLESS NOTED			
		CHRD. SCL.	UNLESS NOTED			
		FRCD.	UNLESS NOTED			
OLD PART NO.		PATTERNING				
MATERIAL NO.						
INCH	[MILLIMETER]					
REMOVE SHARP EDGES						
MATERIAL DESCRIPTION						
ALL DIMENSIONS IN INCHES UNLESS NOTED						
DATE	15-Jun-05	SCALE	3/4			
			DO NOT SCALE PRINT			
			DGC0141			

REV.	DESCRIPTION	DATE	BY	CHKD.
1	REVISED	08-13-83	W.S.	W.S.

DO NOT CONNECT A D1 DRAIN TO A D2 DRAIN PORT ON MULTIPLE DRAIN VALVE. DRAIN MUST BE CLOSED DURING OPERATION. SEE DRAWING #DGC0112 FOR DETAILED LOCATION. SHOWN WITH OPTIONAL 3" NPT FLANGES - P. N. 1920503

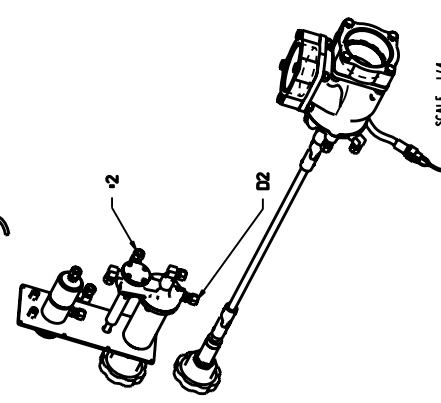
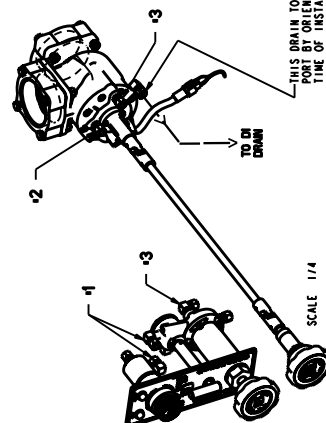
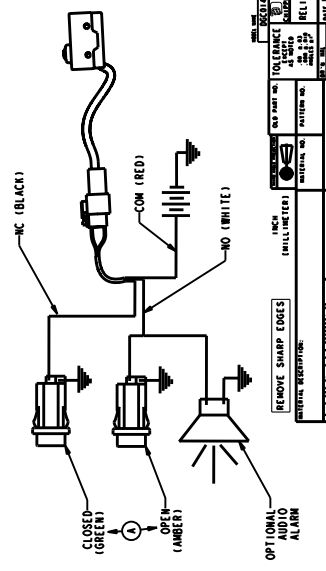
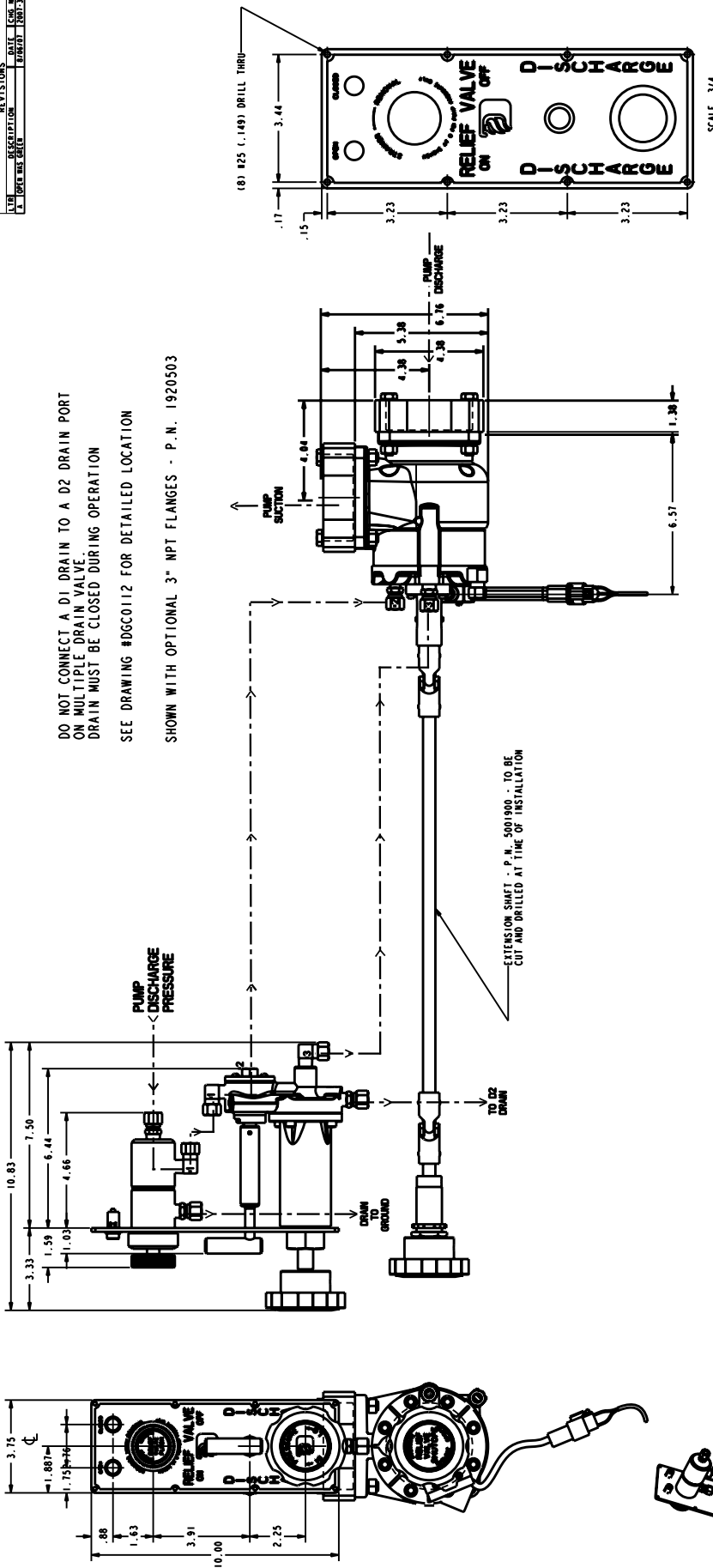

REV.	DESCRIPTION	DATE	BY	CHKD.
1	REVISED	08-13-83	W.S.	W.S.

REMOVE SHARP EDGES  
 ALL DIMENSIONS IN INCHES UNLESS OTHERWISE SPECIFIED  
 THIS DRAWING IS THE PROPERTY OF DUNLOP & CO. INC. IT IS TO BE KEPT IN CONFIDENTIALITY AND NOT REPRODUCED OR COPIED WITHOUT WRITTEN PERMISSION FROM DUNLOP & CO. INC.

INC. DUNLOP & CO. INC. 100 GRANGE AVENUE, WILMINGTON, DE. 19801-0001  
 DUNLOP & CO. INC. 100 GRANGE AVENUE, WILMINGTON, DE. 19801-0001  
 DATE: 12-20-83  
 SCALE: 1/4  
 DSD0800

# W.S. DARLEY & CO.

## Relief Valve Alarm Installation Instruction

**This Alarm is designed to concentrate audible sound in the operator zone only. For optimum Performance, position alarm sound opening so it is facing the operator at a distance of 24 - 36 inches.**

Mount unit in 1.12 diameter panel hole. If panel is thicker than .09 inches, invert nut.

Do not mount with sound opening in an upward position. Do not obstruct opening.

Connect to 12 VDC only.

Two (2) wires are required to complete the circuit. The alarm is sensitive to polarity and will not operate if connected with polarity reversed.

### Relief Valve Alarm Installation Instructions

THIS ALARM IS DESIGNED TO CONCENTRATE AUDIBLE SOUND IN THE OPERATOR ZONE ONLY. FOR OPTIMUM PERFORMANCE, POSITION ALARM SOUND OPENING SO IT IS FACING THE OPERATOR AT A DISTANCE OF 24-36 INCHES.

MOUNT UNIT IN 1.12 DIAMETER PANEL HOLE. IF PANEL IS THICKER THAN .09 IN., INVERT NUT.

DO NOT MOUNT WITH SOUND OPENING IN AN UPWARD POSITION. DO NOT OBSTRUCT OPENING.

CONNECT TO 12 VDC ONLY.

TWO (2) WIRES ARE REQUIRED TO COMPLETE THE CIRCUIT. THE ALARM IS SENSITIVE TO POLARITY AND WILL NOT OPERATE IF CONNECTED WITH POLARITY REVERSED.

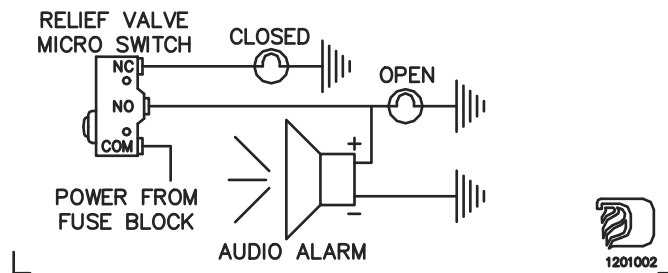

**IF FURTHER INFORMATION IS NEEDED, CALL W.S. DARLEY & CO. AT  
CHIPPEWA FALLS, WI. AT 800-634-7812 or 715-726-2650**

# ***BUTTERFLY VALVE***

Prepared by: RJG  
Approved by: WAH  
Revised by: WAH Via ECO 11337

Rev. A  
Date: 03/16/12  
Rev. Date: 02/19/2016  
1200643.doc

7.66

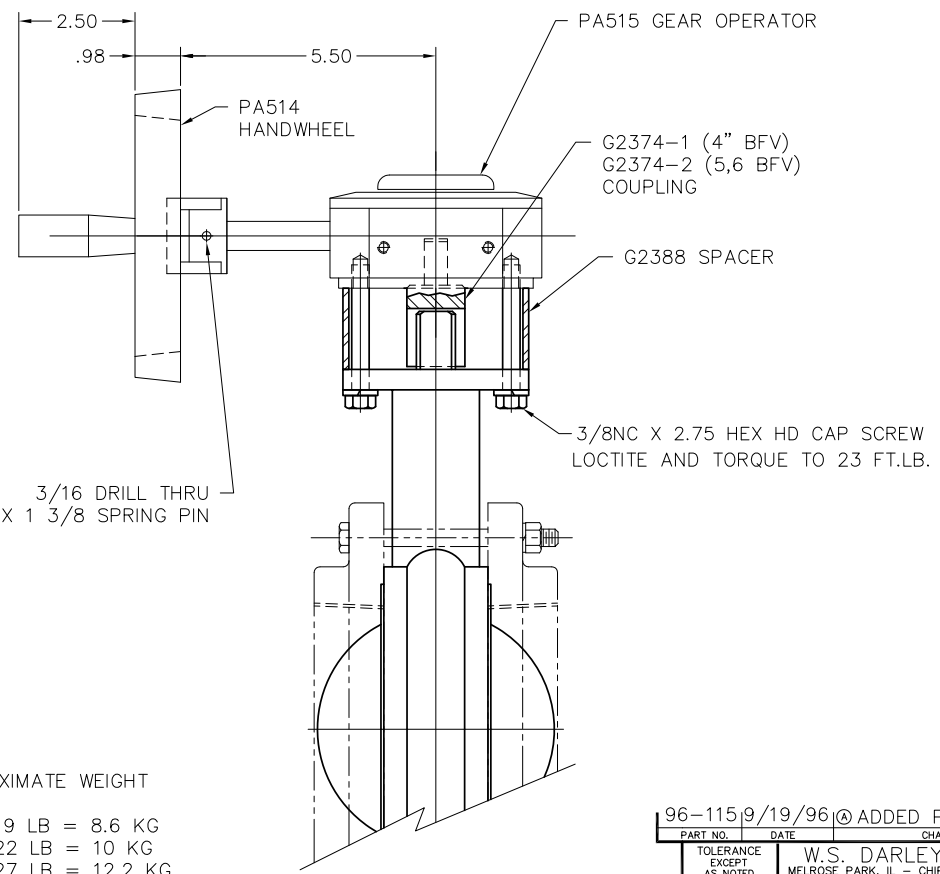
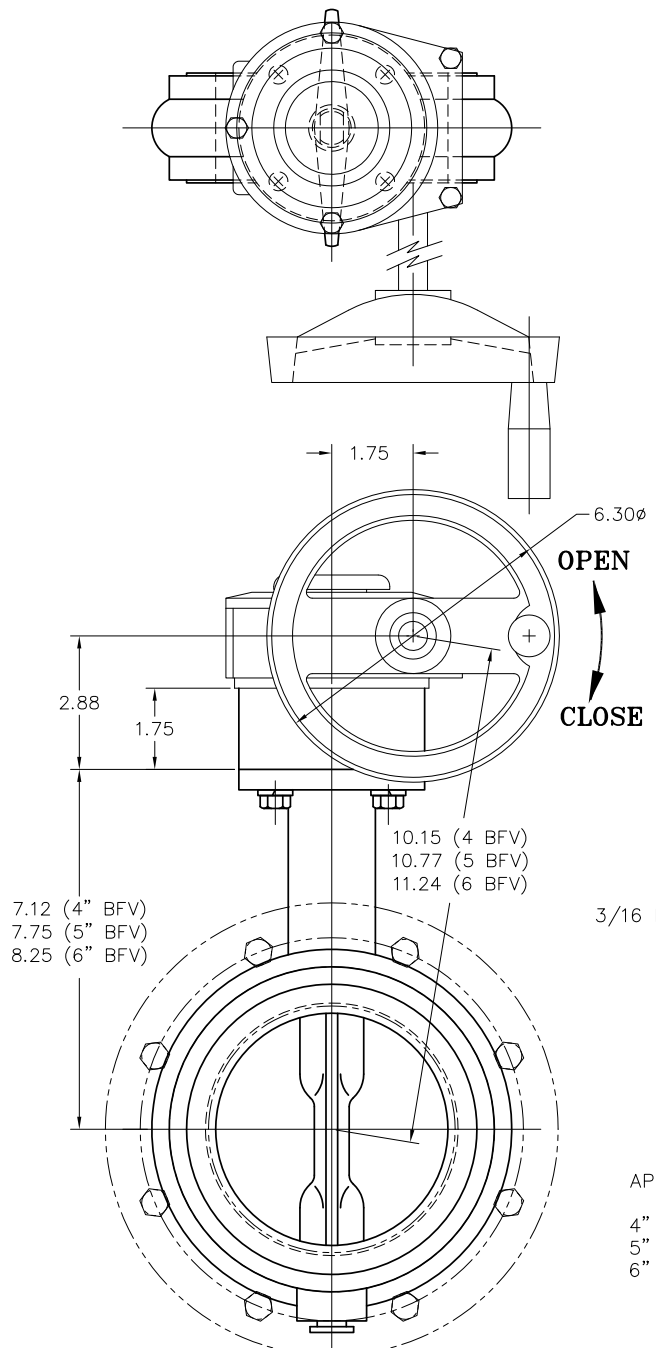

APPROXIMATE WEIGHT  
 4" - 19 LB = 8.6 KG  
 5" - 22 LB = 10 KG  
 6" - 27 LB = 12.2 KG



ATTACH WARNING PLATE (ASSY AM00700) TO CONTROL PANEL VIA REV. NO. 96-115 (REF). ⓐ

96-115 9/19/96 ⓐ ADDED PLATE LMH

PART NO.	DATE	CHANGE
W.S. DARLEY & CO. MELROSE PARK, IL - CHIPPEWA FALLS, WI		
DWG - BTRFLY VALVE ASSY MANUAL CONTROLLED		
DRN DWS	DATE SEP25,91	<b>DGD0104</b>
CHKD	SCALE 1/2	
TRCD		



OLD PART NO.  
G2420

THIS DESIGN IS THE PROPERTY OF W.S. DARLEY AND CO. - UNAUTHORIZED REPRODUCTION IS PROHIBITED

ALL DIMENSIONS IN INCHES UNLESS NOTED

DO NOT SCALE PRINT



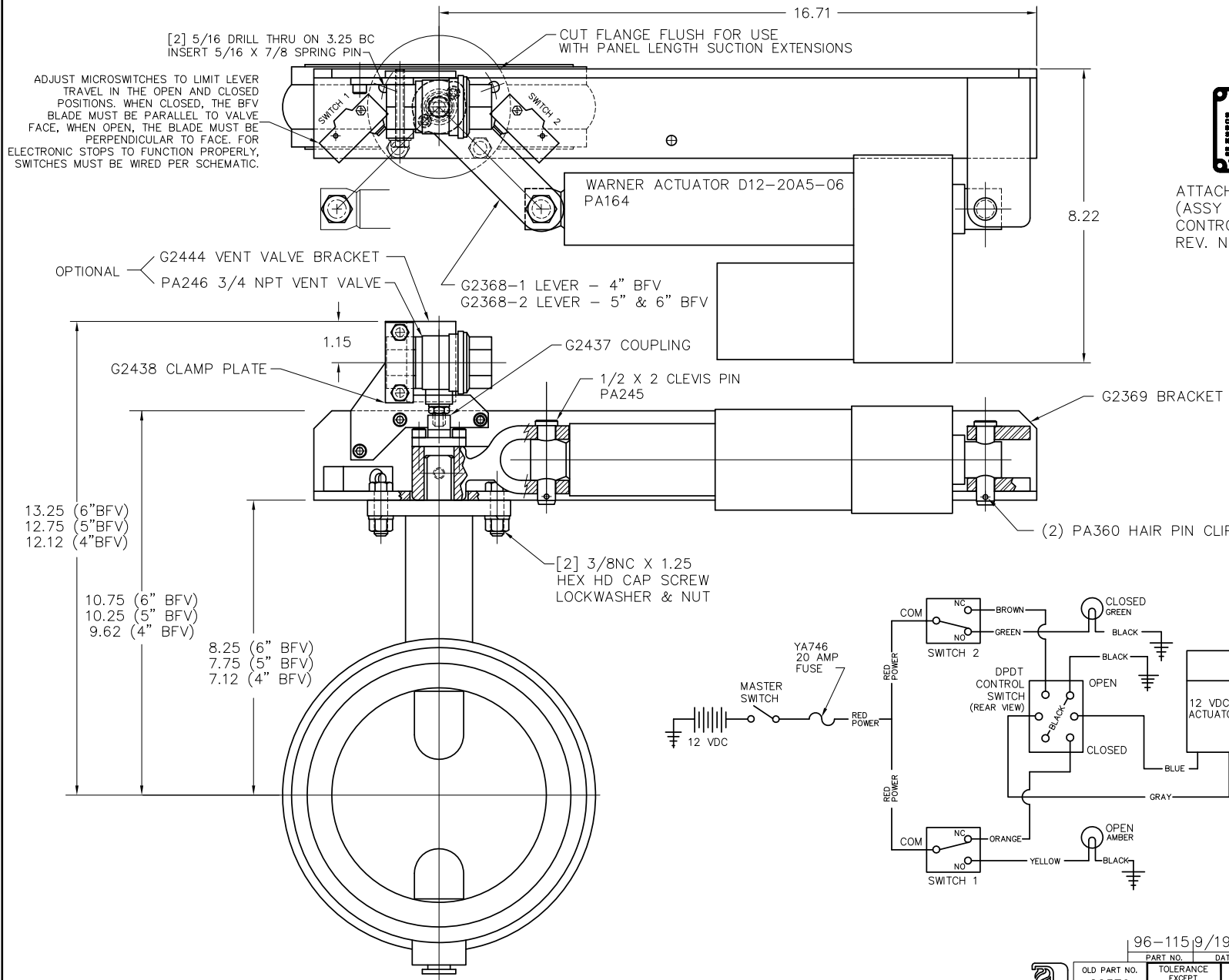

ATTACH WARNING PLATE (ASSY AM00700) TO CONTROL PANEL VIA REV. NO. 96-115 (REF.) ⓐ

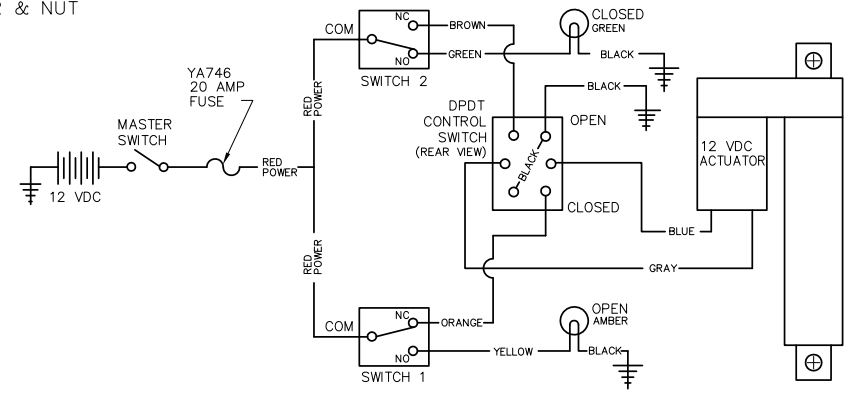

APPROXIMATE WEIGHT = 35 LB = 15.9 KG (6" BFV)  
30 LB = 13.6 KG (5" BFV)  
27 LB = 12.2 KG (4" BFV)

96-115/9/19/96ⓐ ADDED PLATE LMH

PART NO.		DATE		CHANGE	
G2370		W.S. DARLEY & CO.		MELROSE PARK, IL - CHIPPEWA FALLS, WI	
TOLERANCE EXCEPT AS NOTED		DWG - BUTTERFLY VALVE ASSEMBLY ELECTRIC ACTUATED			
FRAC DIM ±.01		DATE NOV20,91			
.00 ±.01		SCALE 1/2			
.000 ±.005		DGD0101			
ANGLES ±1°					
DR'N SEITZ					
CHKD					
TRCD					
MATERIAL:		MATERIAL NO.		PATTERN NO.	
THIS DESIGN IS THE PROPERTY OF W.S. DARLEY AND CO. - UNAUTHORIZED REPRODUCTION IS PROHIBITED		-		-	
ALL DIMENSIONS IN INCHES UNLESS NOTED		DO NOT SCALE PRINT			

**INLET RELIEF VALVE INFORMATION:** (A)

ACTUAL PRESSURE RANGE IS 90PSI - 300PSI  
 THERE MAY BE SOME DIMINISH IN FLOW AT HIGHER  
 PRESSURE SETTINGS. (SETTINGS BELOW 200 PSI  
 RECOMMENDED FOR MOST APPLICATIONS).  
 RELIEF VALVE IS FACTORY SET AT 125 PSI AND  
 WHEN PRESET AT 125 PSI, THE PRESSURE RELIEF  
 VALVE SHALL NOT ALLOW A PRESSURE RISE GREATER  
 THAN 60 PSI AT THE DEVICE INLET WHILE FLOWING A  
 MINIMUM OF 150 GPM.  
 THIS VALVE IS NFPA 2009 1901 COMPLIANT PER SECTION  
 16.6.6.3

**ADJUSTMENT INSTRUCTIONS (IF REQUIRED):** (A)

ADJUST CENTER HEX COUNTERSUNK HEX HEAD PRESSURE  
 ADJUSTING BOLT WITH A 1/4" ALLEN WRENCH, 9/16" OR  
 14 MM SOCKET.  
 TO SET AT THE DESIRED RELIEF PRESSURE, ADJUST THE ADJUSTING  
 BOLT HEAD SO THE TOP OF THE BOLT HEAD IS EVEN WITH  
 THE DESIRED PRESSURE.

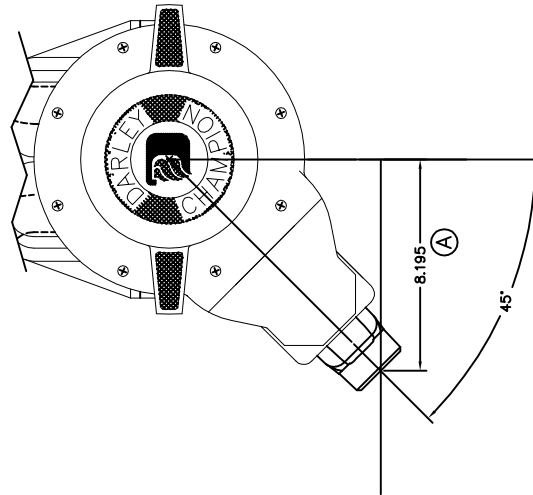

NOTE:  
 SUCTION NIPPLE WILL BE ROTATED  
 45° OFF CENTER WHEN MOUNTED.

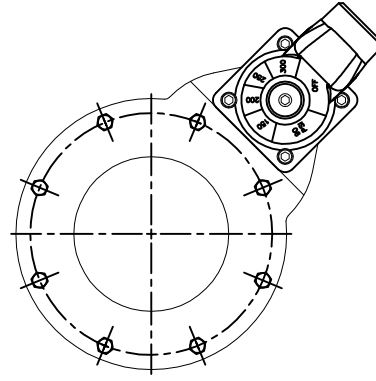
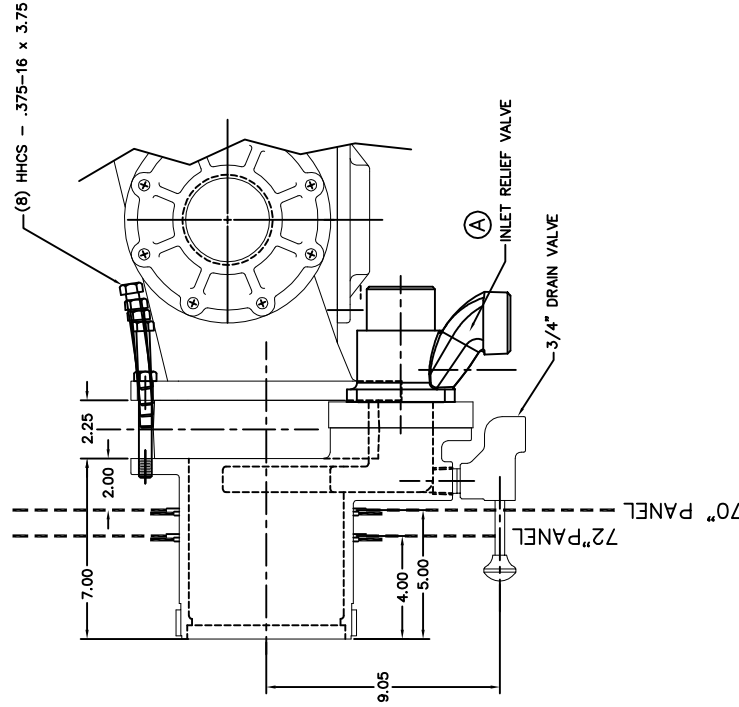

**TYPICAL SUCTION EXTENSION CONFIGURATION FOR EM, LDM, N, & S PUMP**

EXTENSION AND NIPPLE ARE THE SAME FOR 70 & 72" ASSEMBLIES WITH AND WITHOUT BUTTERFLY VALVES. IF BFV IS NOT REQUIRED, THEN KC00300 ASSY W/2.25 THICK SPACER IS USED. USE 1962503 STAINLESS STEEL PANEL TRIM RING



MATERIAL:  
 THIS DESIGN IS THE PROPERTY OF W.S. DARLEY & CO. UNLESS AUTHORIZED REPRODUCTION IS PROHIBITED.  
 ALL DIMENSIONS IN INCHES UNLESS NOTED  
 DO NOT SCALE PRINT

07/18/12	DATE	03FEB,00	DATE	1/4	SCALE
8.20 WAS 5.22, UPDATED INFO AND ADJUSTMENT SECTION CHANGE	UPDATED DRAWING TO REFLECT USE OF 1 1/2" SUCTION RELIEF VALVE	W.S. DARLEY & CO. MELROSE PARK, IL - CHIPPEWA FALLS, WI	INSR - INLET RV ADJUSTMENT	0.3FEB,00	1/4
A - #9312	PART NO.	TOLERANCE EXCEPT AS NOTED	DRN	CHKD	TRGD
		PRAC DIM ±.01	OK	S/L	
		FINISH DIM ±.005			
		ANGLES ±1°			

1200572

# ***PUMP OVERHEAT PROTECTION***

Prepared by: RJG  
Approved by: WAH  
Revised by: WAH Via ECO 11337

Rev. A  
Date: 03/16/12  
Rev. Date: 02/19/2016  
1200643.doc

REVISIONS				
LTR	DESCRIPTION	DATE	CHG NO.	APPR'D
A	REVISED WIRING TO REFLECT HRNESS25FEB2009		5236	SMS
B	ADDED BUSHING, CLOSE NIPPLE, CHECK VALVE, AND NOTES TO MODEL AND DRAWING	06/22/10	6482	RJG

**INSTALLATION INSTRUCTIONS:**

- 1) INSTALL TEMPERATURE SWITCH ON SUCTION SIDE OF PUMP, AS NEAR TO IMPELLER AS POSSIBLE, PREFERABLY BETWEEN THE IMPELLER AND THE RELIEF VALVE.
- 2) INSTALL THE ACTUATOR VALVE ON THE DISCHARGE SIDE OF THE PUMP. ITS LOCATION IS NOT CRITICAL. IT CAN BE MOUNTED DIRECTLY TO THE PUMP OR POSITIONED REMOTELY AND CONNECTED WITH A 3/8 OD MINIMUM LINE.
- 3) VALVE DOES NOT NEED TO BE MOUNTED VERTICALLY AS SHOWN.
- 4) \*PLUMB THE VALVE OUTLET TO TANK, IF DESIRED, USING 3/8 OD MINIMUM LINE. KEEP ALL LINES AS SHORT AS POSSIBLE.
- 5) ATTACH ONE LEAD OF VALVE TO THE TERMINAL ON THE TEMPERATURE SWITCH. ATTACH THE OTHER LEAD TO A FUSED VOLTAGE SOURCE. IF DESIRED, THE TEMPERATURE SWITCH CAN ALSO BE USED TO CONTROL A LIGHT ON THE PANEL NOTIFYING THE OPERATOR THAT OVERHEATING IS OCCURRING AND THE UNIT HAS BEEN ACTIVATED.
- 6) TO TEST THE VALVE: WITH PUMP RUNNING, JUMP THE TERMINALS ON THE TEMPERATURE SWITCH. IF THE VALVE DOES NOT DISCHARGE, IT MAY BE INSTALLED BACKWARDS OR WIRING CONNECTIONS MAY BE INCORRECT.
  - \* CONNECTION TO TANK MAY CAUSE TANK TO OVERHEAT, REDUCING THE EFFECTIVENESS OF THIS DEVICE TO PREVENT FREEZING DAMAGE. WHEN CONNECTING TO TANK, THE VALVE SHOULD BE MOUNTED ON THE TANK, BUT ABOVE THE PUMP.
  - IF THE VALVE IS TO DISCHARGE TO ATMOSPHERE, THE VALVE SHOULD BE MOUNTED ON, OR AS CLOSE TO THE PUMP AS POSSIBLE.

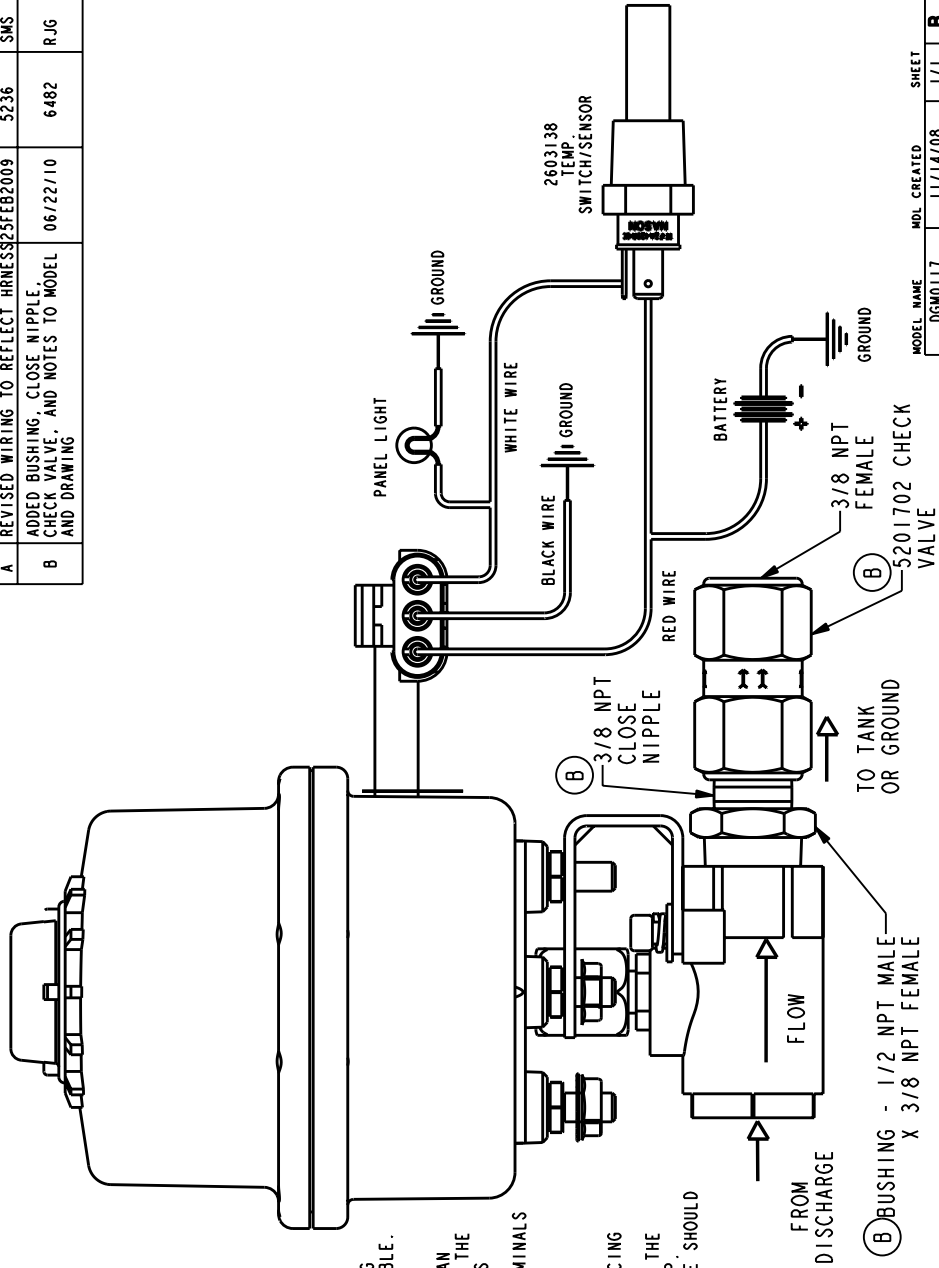

REMOVE SHARP EDGES		INCH (MILLIMETER)		SHEET	
MATERIAL DESCRIPTION:		ALL DIMENSIONS IN INCHES UNLESS NOTED		MODEL NAME	
THIS DESIGN IS THE PROPERTY OF W.S. DARLEY AND CO. UNAUTHORIZED REPRODUCTION IS PROHIBITED		DO NOT SCALE PRINT		DGM0117	
MATERIAL NO.		PATTERN NO.		MDL CREATED	
TOLERANCE EXCEPT AS NOTED .00 ± .03 ANGLES ±1°		SCALE		11/14/08	
DR'N: RJG		DATE: 14-Nov-08		1/1	
CHGD: DMS		SCALE		1/1	
TRCD		SCALE		1/1	
OLD PART NO.		TOLERANCE		W.S. Darley & Co.	
MATERIAL NO.		PATTERN NO.		ITASCA, IL - CHIPPEWA FALLS, WI	
MATERIAL NO.		PATTERN NO.		DWG - THERMAL RELIEF SYSTEM	
MATERIAL NO.		PATTERN NO.		KZCO VALVE, 2603138 TEMP. SENSOR	

REVISIONS

LTR	DESCRIPTION	DATE	CHG NO.	APPR'D

SUPPLIED BY KZCO

White: Switched 12 VDC (+) - Relay Energized "OPEN"  
 Black: Constant 12 VDC (-)  
 Red: Constant 12 VDC (+)

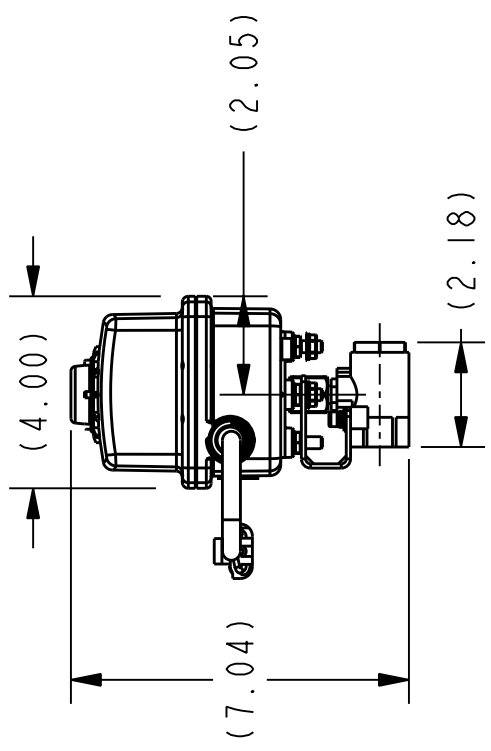
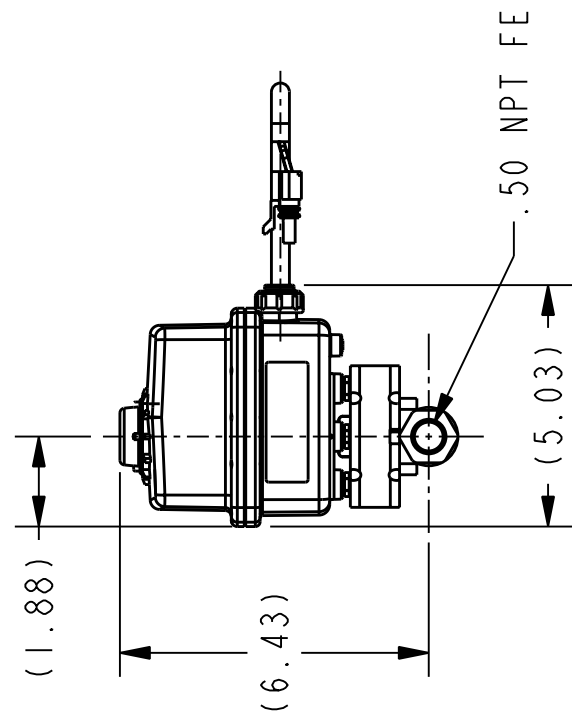
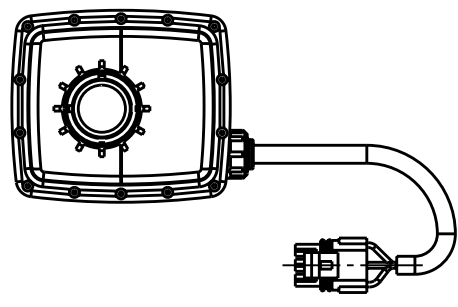
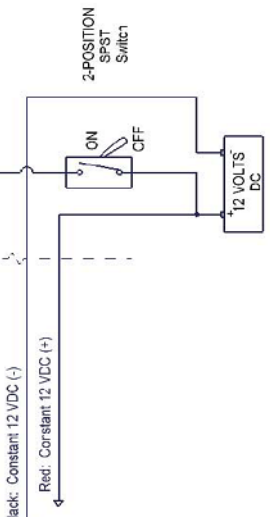

REMOVE SHARP EDGES

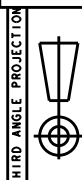

OLD PART NO.

TOLERANCE EXCEPT AS NOTED

DR 'N R/JG

CHKD DWS

TRCD

MATERIAL DESCRIPTION:  
 KZCO 84D23-10D20-PO1

MATERIAL NO.

PATTERN NO.

DATE 13-Nov-08

SCALE 1/4

DO NOT SCALE PRINT

THIS DESIGN IS THE PROPERTY OF  
 W.S. DARLEY AND CO. - UNAUTHORIZED  
 REPRODUCTION IS PROHIBITED

ALL DIMENSIONS IN  
 INCHES UNLESS NOTED

DATE 13-Nov-08

SCALE 1/4

5209401

MODEL NAME 5209401 MDL CREATED 11/13/08 SHEET 1/2

**W.S. Darley & Co.**  
 ITASCA, IL - CHIPPEWA FALLS, WI

VALVE - ACTUATED, 12VDC, .50NPT FE  
 KZCO 84D23-10D20-PO1

**5209401**





**60AD WIRING**  
Standard On/Off applications, SPST Switch  
24 VDC

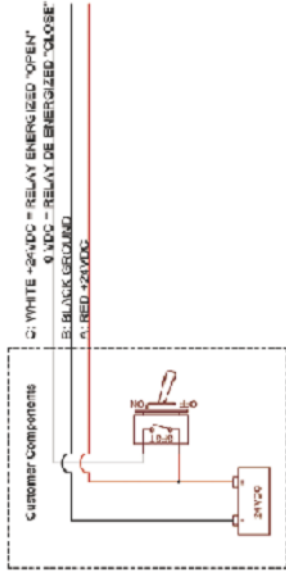

**REVISIONS**

LTR	DESCRIPTION	DATE	CHG NO.	APPR'D

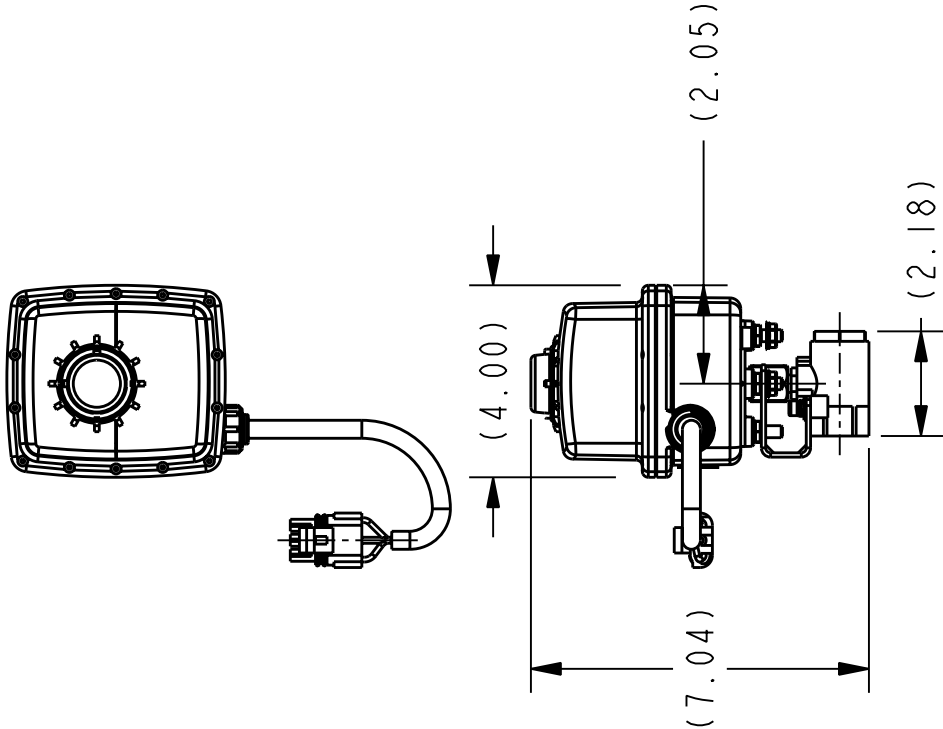

MODEL NAME 5209402 MDL CREATED 11/13/08 SHEET 1/3 A

**W.S. Darley & Co.**  
ITASCA, IL - CHIPPEWA FALLS, WI

VALVE - ACTUATED, 24VDC, .50NPT FE  
KZCO 84D23-60AD-M

DATE 13-Nov-08 SCALE 1/4

**5209402**

**TOLERANCE**  
EXCEPT AS NOTED  
.00 ±.03  
.000 ±.010  
ANGLES ±1°

DR 'N	R/JG
CHKD	DWS
TRCD	

THIRD ANGLE PROJECTION	OLD PART NO.
MATERIAL NO.	PATTERN NO.
DO NOT SCALE PRINT	

**REMOVE SHARP EDGES**

INCH [MILLIMETER]

MATERIAL DESCRIPTION:  
KZCO 84D23-60AD-M

ALL DIMENSIONS IN INCHES UNLESS NOTED

THIS DESIGN IS THE PROPERTY OF W.S. DARLEY AND CO. - UNAUTHORIZED REPRODUCTION IS PROHIBITED

CREATED BY: WASH CREATED ON: 02/09/00 1:49:30 PM REV: --- VER: --- REL: --- LOCATION: ROO F ADN/ET/GRN/HT/PT/RS BRANCH: ---

REVISION	REVISION ECO	REVISION/REVISION DATE	REVISION/REVISION BY
*** .1		3/28/2008 1:49:38 PM	wfedde

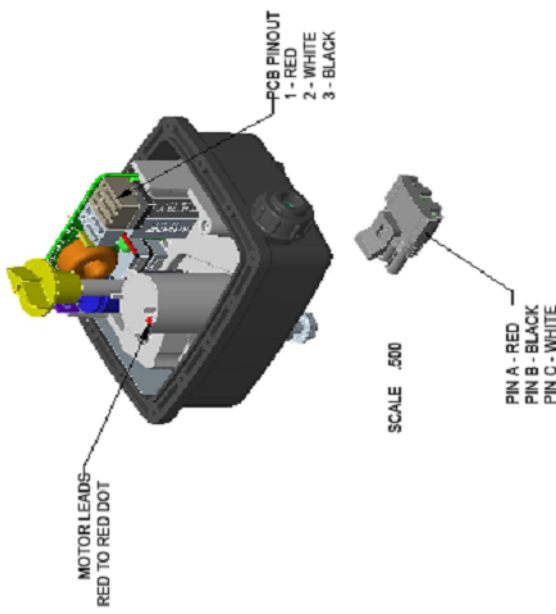

MASRO SET DATA  
 CONTROL INPUT = 1  
 FEEDBACK = 0  
 OPERATION = 0  
 MOTOR = M  
 SPEED CT = 0.8  
 ZEROSET = 136  
 RANGE TOLERANCE = 1  
 ROTATION = CC091  
 ACTUATOR RANGE = 0.0010.00  
 DESIGN VOLTAGE = D  
 DIP SX =  
 LABEL = KZCO  
 OPTIONS = 0  
 PLUG TYPE =  
 TEST PLUG =

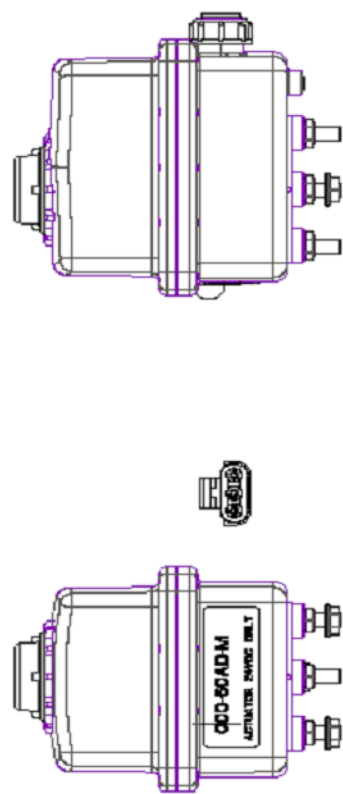

DET	QTY	PART NUMBER	DESCRIPTION	MATERIAL
8	1	EH-502	LABEL, EH ACTUATOR, 2.5" X 1", THERMAL TRANSFER, WHITE	NO_MATERIAL
7	2	OX-222	NUT, HEX HEAD, SERRATED FLANGE, .250-20 UNC-2B	STAINLESS_STEEL_TYPE_303
6	4	EH3-135	STUD, 1/4-20 X 1/2 MTG	STAINLESS_STEEL_TYPE_303
5	1	800018	HARNISS, 60A, 3ST, WP3T, 22.5"	
4	1	EH3-115-Y	FLAG, YELLOW	POLYPROPYLENE_TALC_20
3	1	800488	PCB ASSY, EH3 24VDC 60AD/60DF	
2	1	EH3-110	GEAR ASSY, EH3 MOTOR, EH3 SERIES M1 18 RPM @ 12VDC	
1	1	485-0005	CASE KIT, EH3 IM DOME NYLON M1 & N1 MTR	
DET	QTY	PART NUMBER	DESCRIPTION	MATERIAL

DATE: 2007-04-10 DESIGNED: L. ERDKAMP DRAWN: W. FEDDE APPROVED: A. KOTTAS		DATE: 2007-04-10 DESIGNED: L. ERDKAMP DRAWN: W. FEDDE APPROVED: A. KOTTAS	
TITLE: ACTUATOR, EH3, 8S @ 24VDC		TITLE: ACTUATOR, EH3, 8S @ 24VDC	
REF:		REF:	
PART NO: 000-60AD-M		PART NO: 000-60AD-M	
DRAWING NO: 000-60AD-M		DRAWING NO: 000-60AD-M	
SHEET 1 OF 1		SHEET 1 OF 1	

KZCO inc.  
 21000 W. 10TH AVE  
 DENVER, CO 80202 USA  
 PHONE: +1 303 944 2707  
 FAX: +1 303 944 2022

ALL DIMENSIONS IN UNLESS NOTED TOTAL BUBOUT: 0.00 IN CORNER FINISH: 0.01/0.01 SURFACE FINISH: 125/IN 12.5/IN		DENSITY: 0.07 LB/INCU IN SURF AREA: 103.38 SQ IN VOLUME: 12.00 CU IN	
--	--	--	--

REVISED	REVISION ECD	REVISION/VERSION DATE	REVISION/VERSION BY
-6+		8/12/2008 9:18:50 AM	bgotschall

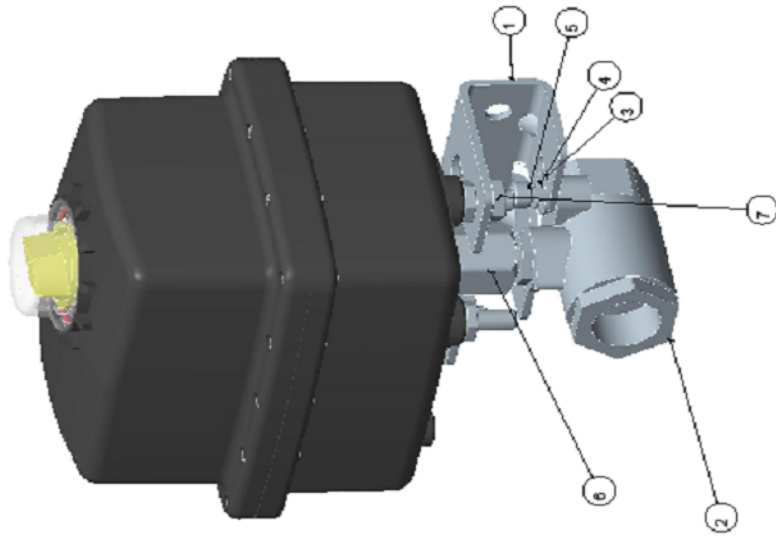
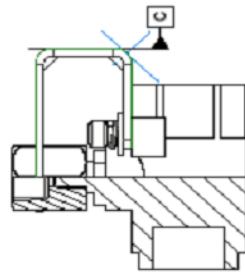
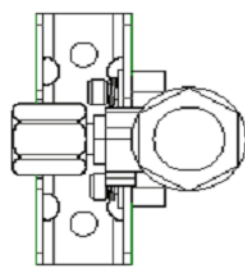
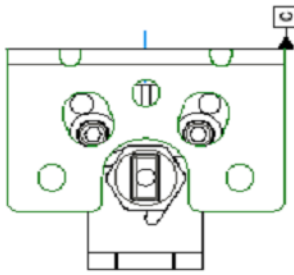

ACTUATOR SHOWN IS REPRESENTATIVE USED ONLY TO SHOW PROPER ORIENTATION TO VALVE.

DET	QTY	PART NUMBER	DESCRIPTION	MATERIAL
7	3	QX-222	NUT, HEX HEAD, SERRATED FLANGE, .250-20 UNC-2B	STAINLESS STEEL TYPE 303
6	1	EH-46	COUPLER, 1/4" - 1/2" APOLLO	STAINLESS STEEL TYPE 316
5	2	EH-158	SCREW, #10-24 X 3/8" SS SOCKET HEAD	STAINLESS STEEL TYPE 303 OR 316
4	2	EHPT-109	WASHER, LOCK, .197 ID X .334 OD X .047 T	STAINLESS STEEL TYPE 316
3	2	EHPT-150	WASHER, FLAT, #10 18-8 SS	STAINLESS STEEL TYPE 316
2	1	EH3-840	VALVE, 1/2" 2-WAY APOLLO 70-103-01 BRONZE BALL VALVE	BRONZE
1	1	EH3-174	BRACKET, MOUNTING EH3 SERIES	STAINLESS STEEL TYPE 304

DESIGNER'S TOLERANCES - ALL DIMENSIONS IN INCHES UNLESS NOTED. TOTAL FINISH: 20/10/10 CORNER BREAK: 20/10/10 SURFACE FINISH: 125/10 X & Y Z AXIS DIMENSIONS: 20/10/10	DATE: 2007-06-08 DESIGNED: L. ERDKAMP DRAWN: C. HOWARD APPROVED: L. ERDKAMP	KZGO INC. 2000 W. PARKWAY GREENWOOD, NE 68304 USA PHONE: +1-402-941-2700 FAX: +1-402-941-2707
SCALE: 750 SIZE: B MATERIAL: AS NOTED	REF: PART NO: 84D23 DRAWING NO: 84D23	TITLE: VALVE KIT, EH3 OFFSET MTG 1/2" 2-PC BRZ
REVISION: -6+		SHEET: 1 OF 1

# **Appendix**

# **Detailed Specification**

## **Darley ZSP 2500-3000**

*A Darley model ZSP 2500-3000 GPM single stage shaft driven fire pump shall be provided and installed.*

*The pump shall be midship or rear mounted and designed to operate through an integral transmission. The pump shall be driven by a driveline from the chassis transmission. The engine, transmission and driveline components shall provide sufficient horsepower and RPM to enable the pump to meet and exceed its rated performance.*

*The pump casing shall be manufactured from Class 40 Cast Iron with a minimum tensile strength of 40,000 PSI. The casing shall be vertically split allowing for access to the impeller and impeller drive shaft without removing the pump from the vehicle in the event maintenance is ever required.*

*The pump shall contain a cored heating jacket feature that, if selected, can be connected into the vehicle cooling system to protect the pump from freezing in cold climates, and to help reject engine heat from engine coolant, providing longer life for the engine.*

### **Pump Shaft**

*The pump shaft shall be precision ground stainless steel. The shaft shall be splined to receive shaped impeller hubs, for greater resistance to wear, torsional vibration, and torque imposed by engine, as well as ease of maintenance and repair.*

### **Impeller**

*The impeller shall be a high strength bronze alloy of mixed flow design, splined to the pump shaft for precision fit, durability, and ease of maintenance. Impeller shall be vacuum cast designed for maximum lift and highest capacity. The seal rings shall be renewable, double labyrinth, wrap around bronze type.*

*Impeller shaft oil seals shall be constructed to be free from steel components except for the internal lip spring. The impeller shaft oil seals shall carry a lifetime warranty against damage from corrosion from water and other fire-fighting fluids.*

*Impeller shaft mechanical seal primary ring shall be constructed of Silicone Carbide material with a mating rating material of Carbon. Due to the superior performance and resistance to failure in the event of "running dry," tungsten carbide or ni-resist face materials shall not meet the requirements of the specification. No Exceptions shall be made to this portion of the specification.*

### **Pump PTO Driven 2 Gear Transmission**

*The transmission case shall be heavy duty 356T6 cast aluminum. Transmission case shall be vacuum resin impregnated to seal casting microstructure. A magnetic drain plug shall be provided. Transmission case shall include a readily accessible lubricant fill port with combination plug/dipstick for checking and maintaining oil level. Transmission case shall be*

*equipped with a removable access plate for quick inspection of gears, shafts, and bearings inside the transmission.*

*The pump drive shaft shall be precision ground, heat treated alloy steel, with a minimum 2"-10 spline. Gears shall be helical design and shall be precision ground for quiet operation and extended life. The gears shall be manufactured from alloy steel, carburized, and heat treated for surface hardness and strength.*

*The bearings provided shall be heavy duty, deep groove, radial and spherical roller type bearings. Sleeve bearings on any portion of the pump or transmission shall be prohibited due to wear, deflection, and alignment concerns. The bearings shall be protected at all openings from road dirt and water splash with oil seals and water slingers.*

*The pump transmission shall include an integrated, positive displacement lubrication system providing pressurized lubrication to transmission gears and bearings. The pressurized lubricant system shall include a closed loop, heat exchanger providing low operating temperatures thus extending lubricant life and change intervals. The lubrication circuit shall include a 100 mesh, stainless steel, oil pickup screen.*

*The transmission shall include a secondary, splash lubrication system which will provide continued bearing and gear lubrication in the event of primary lubrication system malfunction.*

### **High Capacity Vacuum Primer**

*When specified, the pump shall include an integrated, belt-driven, clutch-actuated, high capacity vacuum primer. The high capacity primer will be capable of evacuating 40' of 8" suction hose within 45 seconds with a pump input speed of 1000 rpm. The primer shall be actuated by a panel mounted, manual operated, 'PUSH to PRIME' momentary switch.*

*The primer control shall include an indicator lamp to indicate when the primer is engaged.*

### **Driveline Installation**

*The chassis drivelines shall be sized for intended application and torque requirements. The installation shall comply with driveline manufacturer's guidelines as well as with the pump manufacturer's guidelines. Improper installation will void the warranties provided from the pump manufacturer.*

### **Manuals**

*One manual covering the fire pump transmission and selected options of the fire pump shall be provided with the apparatus in either printed copies or on CD.*



***Corporate Darley Office***

**325 Spring Lake Drive  
Itasca, Illinois 60143-2072  
Toll Free Phone: 800-323-0244  
Phone: 630-735-3500  
Fax: (708) 345-8993**

***Apparatus Division***

**920 Kurth Rd.  
Chippewa Falls, WI 54729  
Toll Free Phone: 800-527-0068  
Phone: 715-726-2645  
Fax: (715) 726-2648**

***Pump Manufacturing***

**1051 Palmer St.  
Chippewa Falls, WI 54729  
Toll Free Phone: 800-634-7812  
Phone: 715-726-2650  
Fax: (715) 726-2656**