

Operator's Manual Table of Contents For Darley Midship Type KHM Fire Pump

		<u>Page #</u>
Description, Operation & Maintenance, & Lubrication-----	1200525	1
Related Drawings-----	DHC0800	2
Mechanical Seal -----	1200583	3-4
Packing Adjustment-----	1200504	5
	1200514	6
Pump Shifting Procedure -----	1200515	7
Manual transmission / Automatic Transmission-----	1200507	8-10
Pump Shift "Air Shift"-----	DGS0500	11
	DGC0701	12
High Pressure Stage-----	1200511	13
	DLC0104	14-15
General Operation-----	1200509	16-17
	1200510	18-20
	1201500-1201502	21-34
Electric Primer-----	1200512	35-36
	DVC0207	37
	DVC0209	38
Multiple Drain Valve -----	1204506	39
	DGC0903	40
Ball Valve-----	1200000	41
	DGC0100	42
Relief Valve "Suction / Discharge Valve"-----	1200508	43-44
	DGC0115	45
	1200503	46-47
	DGC0141	48-49
	DGD0800	50
Tachometer -----	1201002	51
	DGC0105	52
Butterfly Valve -----	1201001	53
	DGD0104	54
	DGD0101	55
Pump Overheat Protection -----	1200572	56
	DGM0117	57
	5209401	58-59
	5209402	60-62

**IF FURTHER INFORMATION IS NEEDED, CALL W.S. DARLEY & CO. AT
CHIPPEWA FALLS, WI. AT 800-634-7812 or 715-726-2650**

This manual is for DARLEY FIRE PUMP:

Model: KHM Pump Serial Number: _____

Description of Pump Type

The **Type KHM** pump is a high speed, single stage, centrifugal pump.

This pump is the basic HM pump adapted to fit the KDM gear case which provides conventional midship mounting in the truck driveline.

Inherent characteristics are compactness, light weight, high efficiency, and a wide range of pumping capabilities.

OPERATION AND MAINTENANCE OF TYPE KHM FIRE PUMP

Right and left, and front and rear locations are referred to from a position facing the pump suction inlet.

Lubrication

Keep the gear case filled with oil to the level of the oil level plug, which is marked on the pump gear case.

Check the oil level every 25 hours or every 3 month, and change it every 50 hours or 6 months.

Use 80W/90 gear lube oil - not grease - in the pump transmission.

CAUTION: Do not overfill.

Inject grease in zerck fittings on the driveline universal joints once a year.

Operation of Pump

The pump gear shift consists of a sliding clutch gear splined to the transmission shaft which can be moved forward to engage the pump clutch gear or to the rear to engage the rear drive shaft connected to the truck drive axle. A neutral position is half way between.

The sliding clutch gear is moved either by direct mechanical linkage from a shift lever, or air powered cylinder controlled by a selector switch. The shift lever must be moved all the way and locked into either ROAD position to drive the truck, or PUMP position to power the pump.

The truck clutch must always be disengaged to stop the rotation of the truck transmission output shaft before shifting into either ROAD or PUMP gear to prevent clashing and damaging the gear teeth. With the manual shift lever, a butt tooth position of gears may be encountered occasionally preventing engagement. If this occurs, move pump shift lever to neutral (half way) position, engage truck clutch momentarily, then disengage the truck clutch and try to shift the pump again.

The pump is always operated with the truck transmission in direct (high) gear, such as 4th on a 4-speed, or 5th on a 5-speed manual transmission, and D or 2.5 on an automatic transmission.

Never run the pump dry except momentarily and at low speeds.

WARNING: Do not use this pump for hose testing.

M.S. DARLEY & CO. Malvern, Park, LU
 TYPE KHM FIRE PUMP

Dr. D.E.M. Senior L.S.
 7-10-79 BHC0809
 H24 Z

OK

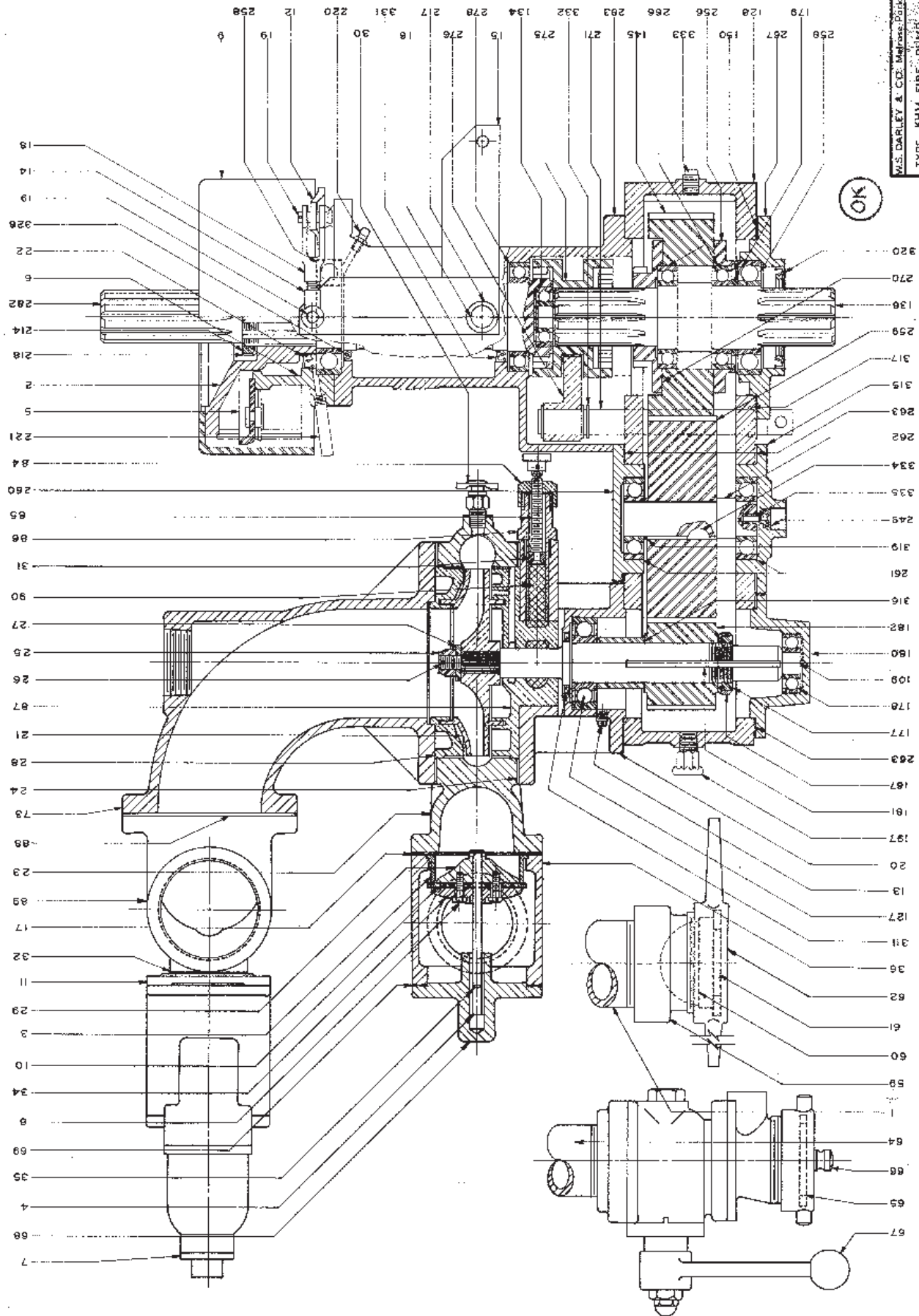

Rev 13
 Date: 06/14/07
 Rev Date: 02/11/11
 1200525

Prepared By: EAS
 Revised By: EAS
 Approved By: TED

Mechanical Shaft Seal

This pump assembly incorporates high quality mechanical shaft seal(s) separating the pump housing components from atmosphere. Depending on the pump design, there may be one or two seals on each impeller shaft.

The seal size, design type, component materials, and housing configuration have been specifically designed for this pump application and rated operating parameters.

Mechanical Seal Basics

A mechanical seal is a device that houses two highly polished components (known as faces). One face rotates, the other is stationary. A secondary elastomer bellows seals the primary ring to the shaft. An o-ring or cup seal seals the mating ring in the housing. The polished seal faces of the primary and mating rings are pressed together by a spring mechanism to provide adequate force to affect a seal. The force acting between the seal faces increases in direct proportion to product pressure.

The elastomer bellows seal utilized in this pump has the following design features:

- Mechanical drive of the primary seal ring. The drive band's notch design eliminates overstressing the elastomer sealing bellows.
- Bellows design provides automatic compensation for shaft endplay, run out, and primary ring wear.
- Seal face contact pressure is controlled by a single, non-clogging coil spring. This coil spring has been custom welded per Darley specifications to eliminate high-speed spring distortion.

The seal housing is designed and ported to provide optimal water flow and pressure assuring proper cooling and flushing of the seal components.

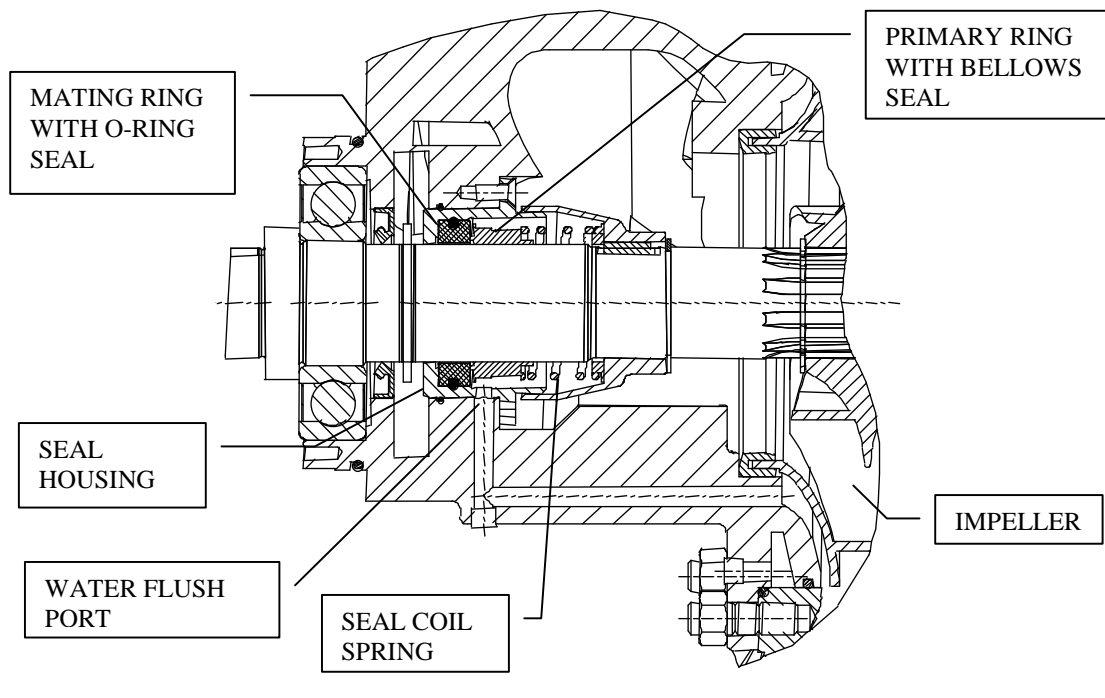

Operation and Maintenance

When operated within rated operating conditions of this pump, these seals will provide trouble free service for extended periods.

Properly selected and applied mechanical shaft seals are leak free and require no adjustment. Should the seal area develop a leak, investigate the cause as soon as possible. Seal failure, leakage, may be the result of; worn seal faces, leaking bellows, or damaged o-rings. These failures may be attributed to bearing failure, impeller blockage, impeller imbalance, seal housing contamination, operating beyond pump design rating, or dry running,

Mechanical shaft seal design relies on the sealed media, in this case, water, to cool and lubricate the sealing surfaces. Therefore, extended dry operation may cause overheating and scoring or damage to the sealing surfaces, resulting in excessive leakage or a much shortened seal life.

To maximize seal life, minimize operation at pump pressures higher than pump rating. While operating at pressures beyond rating will not immediately damage the seal, it will increase sealing surface wear rate.



CAUTION: DO NOT RUN THE PUMP DRY EXCEPT MOMENTARILY AND AT LOW SPEEDS



CAUTION: DO NOT USE THIS PUMP FOR HOSE TESTING



CAUTION: THE MECHANICAL SEAL SHOULD NOT BE RUN DRY, WHILE THE PUMP IS NOT ENTRAINED WITH WATER, FOR A PERIOD LONGER THAN 2 MINUTES. FAILURE TO FOLLOW THIS RECOMMENDATION WILL LEAD TO PREMATURE WEAR AND FAILURE OF YOUR MECHANICAL SHAFT SEAL.



DARLEY

INSTALLATION OF MECHANICAL FACE SEAL WITH O’RING

SPECIAL HANDLING

Study the engineering layout before installing the seal. This shaft seal is a precision product and should be handled and treated with care. Take special care to prevent scratches on the lapped faces of the primary and mating ring. Provide a very clean work area where the assembly will take place. Clean hands prior to assembly.

INSTRUCTION STEPS:

Instructions for Installing a Mechanical Shaft Seal

1. Inspect mating ring pocket in seal housing ensuring it is clean, free of chips, and nick free, to provide a proper sealing surface. Isopropyl alcohol may be used to clean the surfaces if required.

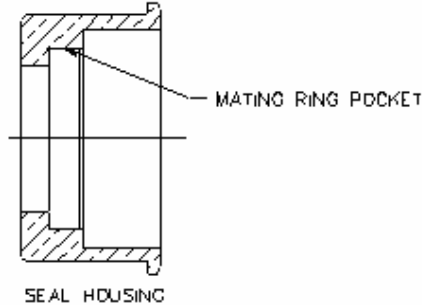

2. Inspect the pump shaft surface under the bellows, ensuring it is clean and nick free to provide a proper sealing surface. Isopropyl alcohol may be used to clean surface if required.

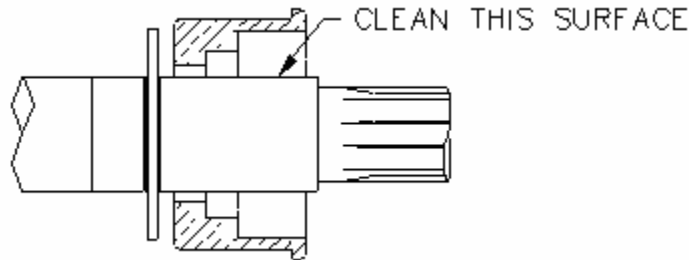

3. Lightly lubricate the o-ring on the mating ring with a single drop of P-80 water soluble rubber lubricant (do not over lubricate) and push it into the cavity using the recommended installation tool or other suitable plastic tube free of contaminants, firmly seating the mating ring square.

Note: The polished face of the mating ring must face out – away from the pump’s gear case. Try to not touch the polished sealing face with your fingers; the oils from your fingerprint can cause the seal to leak. Remove any P-80 from the sealing face after installation.

The approximate size of a drop should be between the sizes of these two circles.

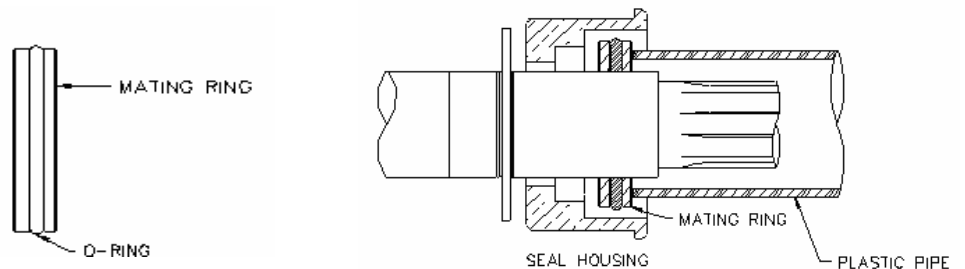

4. Clean the mating ring surface with isopropyl alcohol to remove any fingerprints and any other contaminants left on mating ring.

Note: Steps 5 – 9 need to all be completed with in 15 minutes or less.

5. Apply a small drop of P-80 rubber lubricant or water-soluble lubricant (not soapy water) to the inside diameter of the bellows assembly allowing it to be pushed easily into position.
6. Clean the polished sealing face of the primary ring with a clean lint free rag with isopropyl alcohol to remove all fingerprints and other contaminants.
7. Slide a seal save, similar to X6550, over the shaft splines to ensure that the seal is not damaged during installation. Place the primary ring and lubricated bellows assembly (without the spring) on the shaft, using a proper pusher - push the assembly into position so that the seal surfaces are in contact. Remove the seal save from the shaft.

The approximate size of a drop should be between the sizes of these two circles.

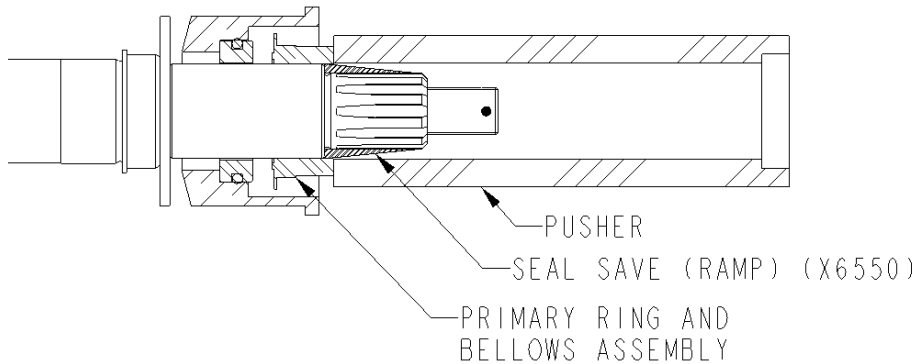
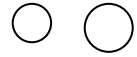

8. Put the spring in place, seated tight against the spring retainer on the primary ring.
Note: Some springs may be slightly tapered, so one end fits the seal better than the other. The end of the spring that best fits the seal should go towards the seal to ensure even spring pressure all the way around.
9. Slide impeller onto impeller shaft, engage the spring into the groove of the impeller hub and install impeller washer, impeller nut, and stainless steel cotter key.

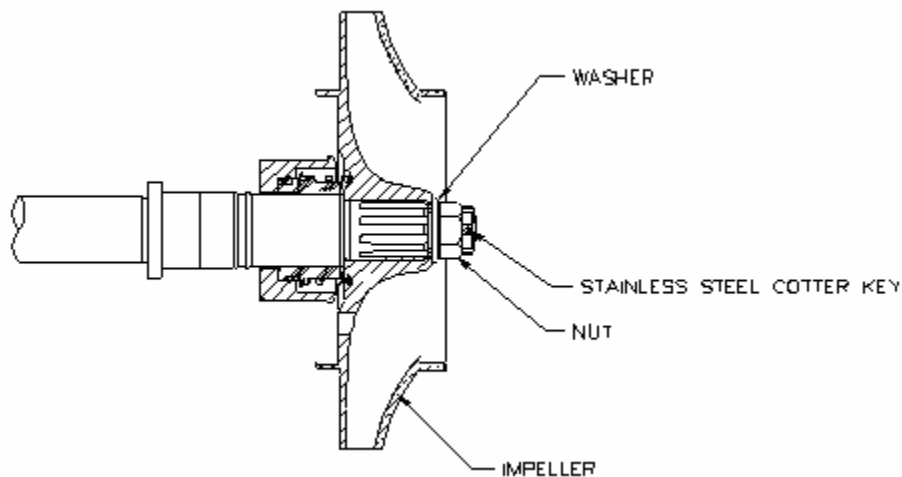

*** Reference pump configuration for individual mechanical seal instructions.*

*** Reference pump assembly drawings and pump assembly tips for further assembly.*

Note: If the seal leaks slightly after assembly, it may be necessary to run the pump for approximately 30 minutes at 50-60 psi to rinse out excess lubricant and other contaminants.

Once a mechanical seal has been installed, it is recommended that it not be reused.

If further information is needed, call **DARLEY** in Chippewa Falls, WI. at 800-634-7812 or 715-726-2650



W. S. DARLEY & CO.

DARLEY INJECTION TYPE STUFFING BOX ADJUSTMENT

⚠ Prop 65 Warning: This product contains lead, a chemical known to the State of California to cause cancer, birth defects, and other reproductive harm. Wash hands after handling.

⚠ Caution: Do not attempt to use anything but Darley injection packing. Using the wrong packing material in your pump may cause catastrophic failure of the pump shaft sealing components.

Only use W.S. Darley & Co.'s plastallic injection packing material. It is made of a special composition of shredded fibers, and a special bonding and lubricating compound.

It is important that the stuffing box is completely filled solid with packing and compressed firm during adjustment to prevent formation of voids and excessive leakage.

To pack the stuffing box when empty and assembled in the pump, remove the packing screw and nut assembly, and insert pellet form packing into the packing plunger guide. Replace the packing screw assembly and use a hand speed wrench to force the pellets into the gland. **DO NOT USE A POWER TOOL!** Repeat pellet additions while turning the impeller shaft by hand until resistance to turning is felt when the stuffing box is almost full. Continue turning packing screw by hand using a standard 6" long 9/16" end wrench until 4 lb. of force is felt at the end of the wrench. This is equivalent to 2 ft-lb or 24 in-lb torque. Continue turning until a few flakes of packing are extruded out the opening between the impeller shaft and the stuffing box hole. The gland is now ready for pressure testing or pumping.

After priming the pump with water, start the pump and raise the discharge pressure to 50 psi. Tighten the packing screw using a 6" long 9/16" end wrench until 4 lb. force is felt at the end of the wrench (24 in-lb torque). Continue operating the pump at 50 psi for 5 minutes to dissipate packing pressure against the shaft and permit cooling water to flow between the shaft and stuffing box hole. Make sure that water actually does come through before operating pump at any higher pressure. The normal drip rate may vary between 5 and 60 drops per minute.

Operate the pump for 10 minutes at the highest normal operating pressure flowing sufficient water to prevent overheating. Do not run the pump blocked tight. Lower discharge pressure to 50 psi and repeat the packing screw tightening procedure outlined above.

The pump may now be operated for any time period required within its rated capacity. However, the drip rate should be monitored more frequently during the first few hours, and adjusted if necessary to achieve a stable flow rate. Several more adjustments may be required.

If further information is needed, call **W.S. DARLEY & CO.**
at Chippewa Falls, WI. at 800-634-7812 or 715-726-2650

SUMMARY OF THINGS TO REMEMBER

1. Always shift pump clutches with engine clutch disengaged.
2. Do not clash clutch gears when shifting.
3. Close booster valves, drain valves, cooling line and third stage discharge valve before attempting to prime the pump.
4. Always keep primer shut-off valve closed, except while priming.
5. Re-open and close primer valve to re-prime or eliminate trapped air from suction line.
6. Always drive midship mounted pump with truck transmission in direct (high) gear lock up.
7. Never run the pump without water in it except momentarily while priming.
8. Accelerate and retard speed of engine gradually.
9. Watch the engine temperature, and start the cooling water at the first signs of overheating.
10. Keep good gaskets in suction hoses, and handle carefully to avoid damage to coupling threads.
11. Air leakage into suction lines is the most frequent source of trouble when pumping from a suction lift (draft).
12. Always use a suction strainer when pumping from draft, and a hydrant strainer when pumping from a hydrant.
13. Foreign matter in impellers is a result of failure to use adequate strainers and is a common source of trouble.
14. Drain pump immediately after each run. This is especially critical in freezing conditions.
15. Do not run the pump long with discharge completely shut off.
16. Do not close a "Shutoff" nozzle when pumping with motor throttle wide open, unless relief valve or pressure regulator is set for the correct pressure.
17. Keep the pump gear case filled with oil to the level of the oil level plug/dipstick.
18. Check oil level in the pump transmission after every 25 hours of operation or 3 months, and changed it after every 50 hours of operation or 6 months.
19. In such equipped transmissions, once the oil is drained, remove the strainer screen oil sump fitting and thoroughly cleanse in a parts washer or with isopropyl alcohol, ensuring any debris is washed away.
20. If pump is equipped with a Darley plastallic (injection) packing shaft seal, check the drip rate frequently, and adjust according to the packing adjustment instruction, as required. The drip rate may vary between 5 and 60 drops per minute.
21. Work all suction and discharge valves often to ensure free and easy operation.

PUMP SHIFTING PROCEDURE

For trucks equipped with manual transmissions, the following shifting procedure should be followed for pump operation:

1. Set parking brake.
2. Disengage truck clutch to stop shaft rotation.
3. Move pump shift lever to PUMP position.
4. Move truck transmission shift lever to neutral position.
5. Engage truck clutch.
6. Prime the pump (see priming instructions).
7. Disengage the truck clutch.
8. Move truck transmission shift lever to direct drive position and lock in place with safety latch.
9. Engage truck clutch to begin pumping.

If the power pump shift is provided, the procedure is identical except green indicator light (if provided) will come on at step #3 to show pump gear has been engaged.

To return to road operation:

1. Disengage truck clutch to stop shaft rotation.
2. Move truck transmission shift lever to neutral position.
3. Move pump shift lever to ROAD position.

When the truck is equipped with an automatic transmission, a danger exists that if the operator forgets to move the pump shift lever to PUMP position, and at the same time place transmission selector lever in high gear before leaving cab, the engine will continue to run due to converter slip. Upon advancing the vernier throttle at the pump operators panel, the engine could overcome the parking brake and accidentally move the truck. To prevent this possibility, the following shifting procedure should be followed for pump operation:

1. Set parking brake.
2. Place automatic transmission shift selector in neutral.
3. Move pump shift lever to PUMP position. "Pump Engaged" light in cab should now come on.
4. Prime the pump (see Priming Instructions).
5. Move automatic transmission shift selector to direct drive position (See Automatic Transmission Instructions).
6. Lock automatic transmission shift selector in direct drive position with safety latch provided.
7. Check that the parking brake is fully engaged.
8. Depress foot accelerator and observe that speedometer registers MPH. If pump is not engaged, speedometer will not indicate MPH.
9. Listen for pump shift and sound of pump gears turning.
10. At pump operators position, observe that the green indicator light above vernier throttle control is on. **Do not** operate throttle unless light is on.
11. Observe discharge pressure gage on panel while advancing vernier throttle, to ensure that it is indicating pressure. If Pump is not engaged, no pressure will show.
12. Remember, the vernier throttle has a quick release emergency center button. Push it all the way in immediately, should the truck move.

To return to ROAD OPERATION:

1. Place the truck transmission selector lever in reverse position to stop forward rotation of transmission shaft.
2. Move transmission selector to neutral, and at the same time, move the pump shift lever from PUMP to the ROAD position.

OPERATION OF PUMP SHIFT WITH AUTOMATIC TRANSMISSION

The pump gear shift consists of a sliding clutch gear splined to the transmission shaft which can be moved forward to engage the pump clutch gear, or to the rear to engage the rear drive shaft connected to the truck drive axle.

The sliding clutch gear is moved either by direct mechanical linkage from a notched quadrant shift lever, or by an air power cylinder controlled by a selector valve. The shift lever or selector valve must be moved all the way and locked for either ROAD position to drive truck or PUMP position to pump.

MANUAL PUMP GEAR SHIFT PROCEDURE

With trucking parking brake set, the truck transmission shift selector must be in neutral position to stop rotation of truck transmission output shaft before shifting into either ROAD or PUMP gear to prevent clashing and damage to gear teeth. With a manual pump gear shift control, a butt tooth position of gears may be encountered preventing engagement and "Pump Engaged" light from coming on. If this occurs, move transmission shift selector momentarily into any forward gear position with engine idling, then return to neutral. Wait approximately 5 seconds until shaft stops turning. Moving the pump shift lever to PUMP position again should complete the pump shift and turn on the "Pump Engaged" light. Repeat this procedure if a butt tooth condition is again encountered. Pump priming should be completed before shift to PUMP position.

AIR POWER PUMP GEAR SHIFT PROCEDURE

With the air power pump gear shift control a butt tooth condition may also occur preventing engagement and "Pump Engaged" light from coming on. This can be easily overcome by momentarily placing truck transmission in any forward gear position with engine idling after the pump shift valve is placed in the PUMP position. Shaft rotation will complete the shift and turn on green "Pump Engaged" light. Transmission shift should be returned to neutral position after "Pump Engaged" light comes on for the pump priming period.

The above procedure insures that the pump shift is completed and the "Pump Engaged" light comes on. An alternate procedure in case of a butt tooth condition is simply to wait until the transmission is placed into pump drive gear position, when shaft rotation will immediately permit pump gears to mesh into full engagement.

The pump is usually operated with truck transmission in direct (high) gear such as D or 2-5. Overdrive may be required with very low speed engines.

When the truck is equipped with an automatic transmission, a danger exists that should the operator forget to move the pump shift valve to PUMP position, and at the same time place transmission selector in high gear before leaving cab, the engine will continue to run due to converter slip. If the operator advances the vernier throttle at the pump operators panel, the engine could overcome the parking brake and cause the truck to move. To prevent this possibility, the following shifting procedure should be followed for PUMP position:

1. Read and fully understand pump Operators Manual before proceeding.
2. Set parking brake and idle engine.
3. Place automatic transmission shift selector in neutral.
4. Move pump shift lever or valve to PUMP position. "Pump Engaged" green light in cab should now come on. If not, momentarily place truck transmission shift selector in a forward gear to complete pump shift, then return to neutral position. Green light will now be on.

5. Prime pump.
6. Move automatic transmission shift selector to direct drive position. "OK to Pump" green light in cab should now be on.
7. Lock automatic transmission shift selector in direct drive.
8. Listen for sound of pump gears turning. Speedometer will show MPH unless connected to the wheel.
9. At pump operators position, observe the green indicator warning light near vernier throttle control. **WARNING: DO NOT OPEN THROTTLE UNLESS LIGHT IS ON.**
10. Advance throttle to provide a minimum of 900 rpm idle speed. Observe discharge pressure gage on panel while advancing vernier throttle to make sure it is indicating pressure. If pump is not engaged or the pump is not primed, no pressure will show.

The vernier throttle has a quick release emergency red center button. Push it all the way in to return the engine to idle if necessary in an emergency situation

To return to ROAD operation:

1. Throttle engine back to idle.
2. Place the truck transmission selector lever in neutral position. Wait approximately 5 seconds until drive shaft stops rotating.
3. Move pump shift lever or valve from PUMP to ROAD position. "Pump Engaged" green indicator light should be off. A butt tooth condition may require momentary engagement of transmission to complete the shift.

OPERATION OF PUMP SHIFT WITH MANUAL TRANSMISSION

The pump gear shift consists of a sliding clutch gear, splined to the transmission shaft which can be moved forward to engage the pump clutch gear, or to the rear to engage the rear drive shaft connected to the truck drive axle. A neutral position is half way between.

The sliding clutch gear is moved either by direct mechanical linkage from a notched quadrant shift lever, or by a vacuum or air power cylinder controlled by a selector switch. The shift lever must be moved all the way and locked for either ROAD position to drive truck or PUMP position to power pump.

The truck clutch must always be disengaged to stop rotation of truck transmission output shaft before shifting into either ROAD or PUMP gear to prevent clashing and damage to gear teeth. With the manual shift lever, a butt tooth position of gears may be encountered occasionally preventing engagement. If this occurs, move pump shift lever to neutral (half way) position, engage truck clutch momentarily, then disengage truck clutch and try pump shift again.

The pump is always operated with truck transmission in direct (high) gear, such as 4th on a 4 speed or 5th on 5 speed transmission.

The following shifting procedure should be followed for PUMP operation:

1. Set parking brake.
2. Disengage truck clutch.
3. Move pump shift lever (valve) to PUMP position. "PUMP ENGAGED" green light in cab should now come on.
4. Move truck transmission shift lever to neutral position.
5. Engage truck clutch.
6. Prime pump (See Priming Instructions).
7. Disengage truck clutch.
8. Move truck transmission shift lever to direct drive position and lock in place with safety latch provided.
9. Slowly engage truck clutch to begin pumping.

TO RETURN TO ROAD OPERATION

1. Disengage truck clutch to stop shaft rotation. Allow 10 seconds for shaft to stop rotating.
2. Move truck transmission shift lever to neutral position.
3. Move pump shift lever (valve) to ROAD position.

CAUTION

Follow the procedures step by step as indicated.

**IF FURTHER INFORMATION IS NEEDED, CALL W.S. DARLEY & CO. AT
CHIPPEWA FALLS, WI. AT 800-634-7812 or 715-726-2650**

REVISIONS

SYM.	DATE	BY	REVISION

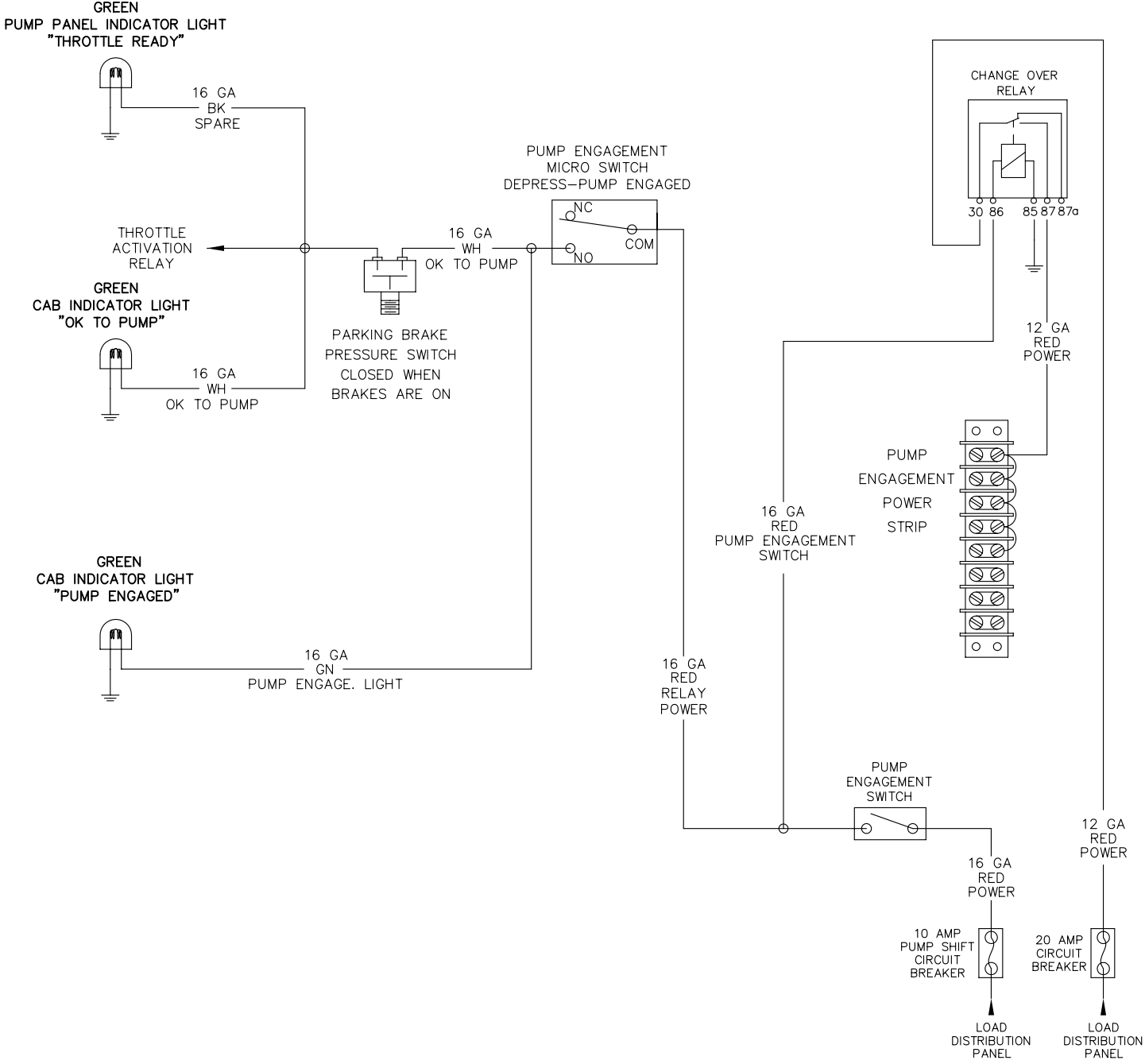

ELECTRICAL SCHEMATIC
MANUAL TRANSMISSION
PUMP ENGAGEMENT



W.S. Darley & Co.
APPARATUS DIVISION
920 KURTH ROAD
CHIPPEWA FALLS, WISCONSIN 54729
1-715-726-2645

DWG BY	JSS	SCALE	NONE	REV
DATE	7-23-02	JOB NO.		DWG. NO. DGS1202

REVISIONS			
LTR	DESCRIPTION	DATE	CHG NO. APPR'D

NOTE: CONNECT TO AIR SOURCE THAT HAS AN 80 PSI PRESSURE PROTECTION VALVE
75 TO 120 PSI AIR SUPPLY

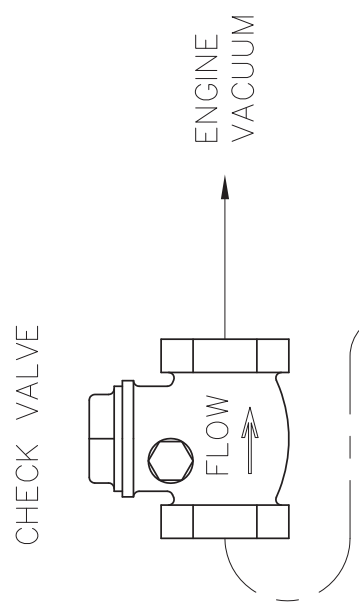

ENGINE VACUUM

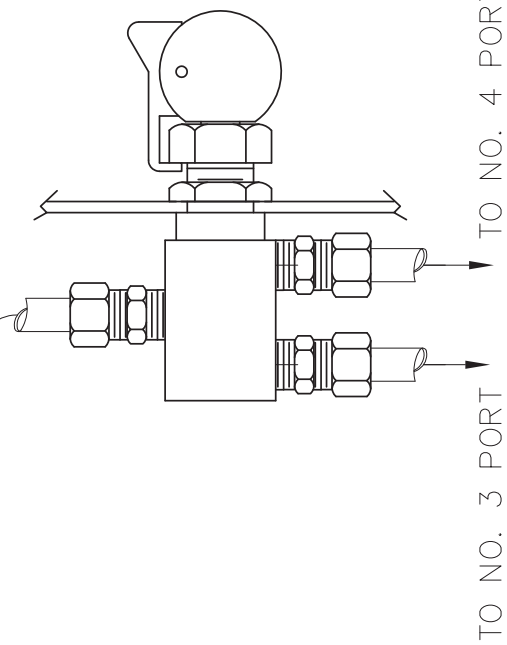

VACUUM SHIFT PIPING DIAGRAM
3" DIA. CYLINDER

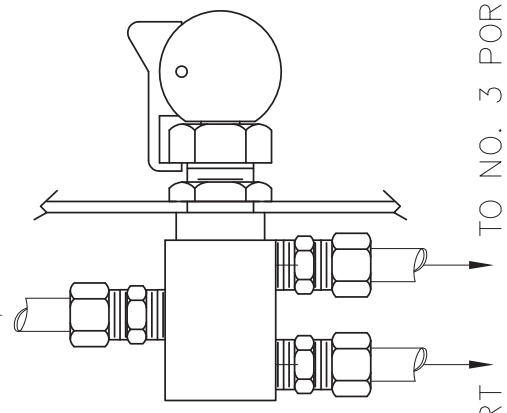

AIR PRESSURE SHIFT PIPING DIAGRAM
1-1/8 DIA. CYLINDER

INCH [MILLIMETER]
THIRD ANGLE PROJECTION



W.S. DARLEY & CO.
MELROSE PARK, IL - CHIPPEWA FALLS, WI

DWG - POWER SHIFT VALVE

DR'N	TED
CHKD	
TRCD	

DO NOT SCALE PRINT

ALL DIMENSIONS IN INCHES UNLESS NOTED

THIS DESIGN IS THE PROPERTY OF W.S. DARLEY AND CO. - UNAUTHORIZED REPRODUCTION IS PROHIBITED

DGS0500

REVISIONS			
LT/R	DESCRIPTION	DATE	CHG. NO. APPRD

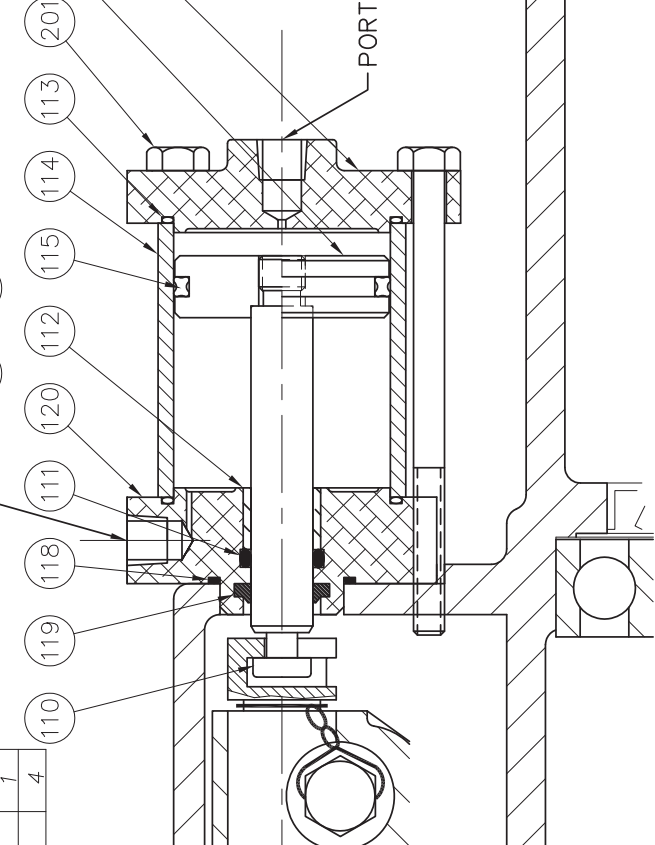
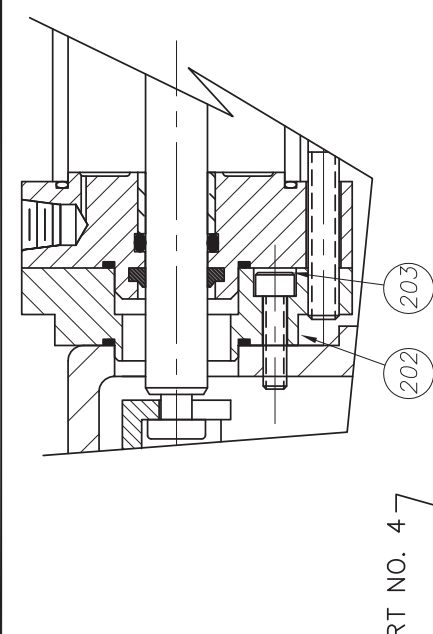

PARTS LIST		
REP. NO.	DESCRIPTION	QTY.
110	PISTON ROD	1
111	ORING - ROD	1
112	OILITE SLEEVE BEARING	1
113	O'RING	2
114	CYLINDER	1
115	QUAD. RING SEAL	1
116	CYLINDER END	1
118	O'RING	1
119	WIPER RING	1
120	CYLINDER HEAD	1
121	PISTON	1
201	CYLINDER SCREWS	3
202	ADAPTER	1
203	ADAPTER SCREWS	4

REFERENCE SPEC AY00201 (G427A1)
& AY00202 (G427A2)



W.S. DARLEY & CO.
MELROSE PARK, IL - CHIPPEWA FALLS, WI

DWG - 1.75" AIR CYLINDER

DATE JUN02,93
SCALE 1/1

DGC0701

THIS DESIGN IS THE PROPERTY OF W.S. DARLEY AND CO. - UNAUTHORIZED REPRODUCTION IS PROHIBITED

ALL DIMENSIONS IN INCHES UNLESS NOTED

DO NOT SCALE PRINT

OLD PART NO. G2514

INCH [MILLIMETER] THIRD ANGLE PROJECTION

OPERATION OF OPTIONAL HIGH PRESSURE STAGE

The sliding gear clutch which drives the optional high pressure stage is operated by a shift lever marked "FOG" for pumping position, and "OUT" for disengaged position. The shift lever must be locked in one or the other of these positions before the pump can be started.

The high pressure stage clutch must not be shifted while the main pump is running.

When the main pump is in operation, it must always be stopped (engine clutch disengaged) for shifting of the high pressure stage clutch either in or out.

The high pressure stage is always primed by pressure from the main pump.

The high pressure stage has a small by-pass line with a valve to the booster tank. Open the by-pass valve when running with the high pressure stage discharge lines completely shut off.

HIGH PRESSURE BOOSTER PUMP DRAWING DLC0104

Rep. No.	Name of Part	Qty	Rep. No.	Name of Part	Qty
1	Inlet Pipe	1	26	Pipe Plug	1
2	Cotter Pin	1	27	Strainer Fitting	1
3	Impeller Pin	1	28	Inlet Tee	1
4	Flange O-ring	1	29	Close Nipple	1
5	Impeller Washer	1	30	Inlet Flange	1
6	Impeller Spacer	1	31	Seal Ring	1
7	Stuffing Box Head	1	32	Pump Casing	1
8	Pump Packing	10	33	Impeller	1
9	Water Slinger	1	34	Pump Casing Gasket	1
10	Impeller Shaft Oil Seal	1	35	Stuffing Box Gasket	1
11	Packing Cylinder	1	36	Idler Shaft Bearing	2
12	Gland Stud Piston	1	37	Shift Bar Oil Seal	1
13	Gland Nut	1	38	Gearcase Gasket	2
14	Packing Screw	1	39	Idler Shaft Spacer	1
15	Impeller Shaft Bearing	1	40	Idler Shaft	1
16	Impeller Shaft	1	41	Alignment Pin	2
17	Shift Collar	1	42	Idler Gear	1
18	Pump Drive Pinion	1	43	Gearcase Spacer	1
19	Gear Case	1	44	Idler Gear Key	1
20	Pinion Spacer	1	45	Oil Level & Fill plug	1
21	Impeller Shaft Bearing	1	46	Bearing Cap	1
22	Bearing Cap Gasket	2	47	Shift Bar O-ring	1
23	Bearing Cap	1	48	Shift Bar	1
24	Retaining Ring	2	49	Retaining Ring	2
25	Strainer Sleeve	1			

**IF FURTHER INFORMATION IS NEEDED, CALL W.S. DARLEY & CO. AT
CHIPPEWA FALLS, WI. AT 800-634-7812 or 715-726-2650**

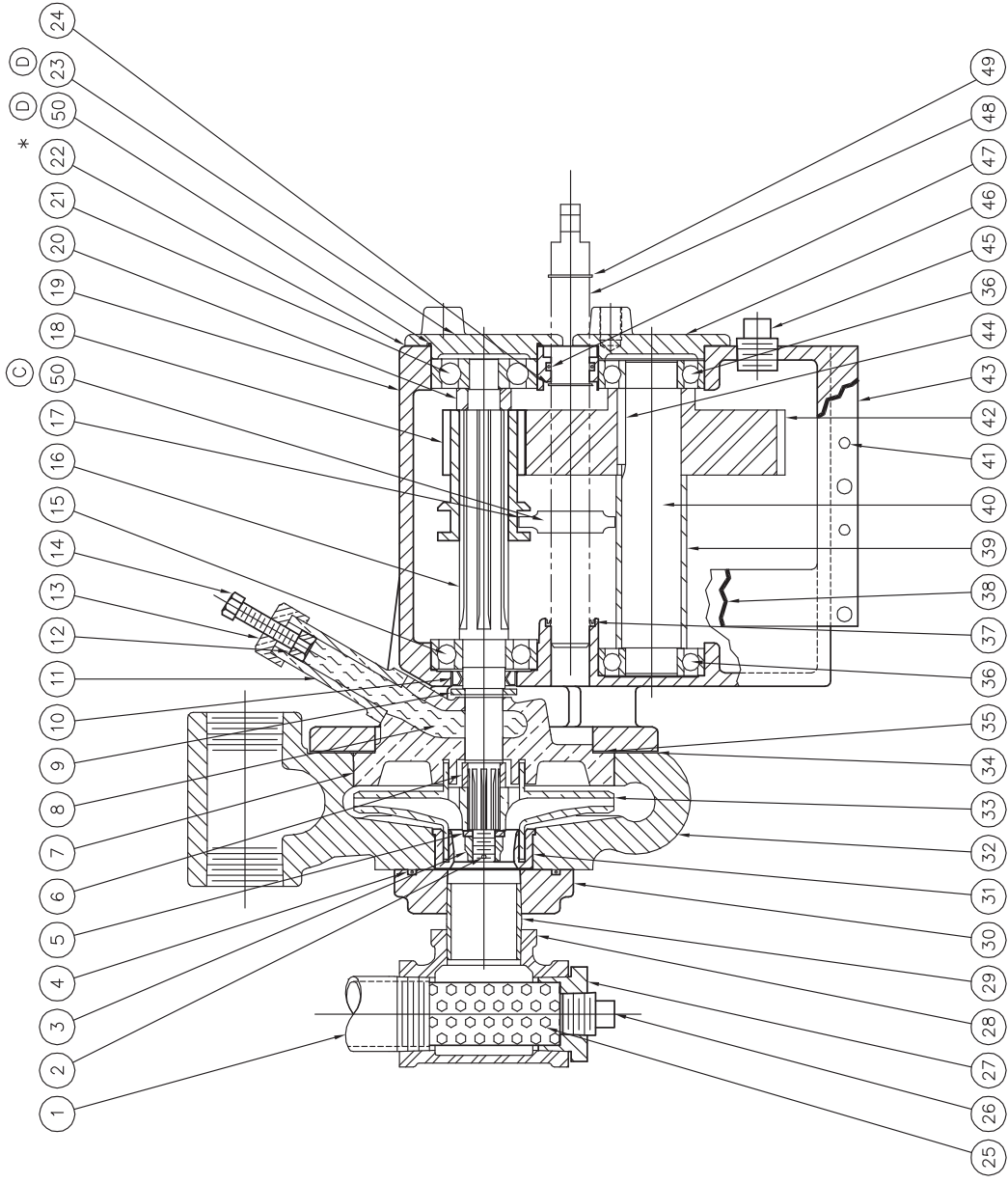

(D) REPL 2302600 W/ 2302604 AND 3601007 23SEP05 2005-285 CKE
 (C) 2002-134 SHCS ADDED 09SEP02 JSS
 * GASKET REMOVED 5/94
 (49) ADDED 3-23-90

TOLERANCE
 UNLESS OTHERWISE SPECIFIED
 FRACTIONAL DIMENSIONS ±.001
 DECIMAL DIMENSIONS ±.0005
 ANGLES ±1°

W.S. DARLEY & CO.
 MELROSE PARK, ILL. - CHIPPEWA FALLS, WI.

DWG - LDM SECOND STAGE
 CROSS SECTION PUMP ASSY

DATE AUG28.89
 SCALE 1/2

DL0104

OLD PART NO.
 L88

DO NOT SCALE PRINT

ALL DIMENSIONS IN INCHES UNLESS NOTED

THIS DRAWING IS THE PROPERTY OF W.S. DARLEY & CO. UNAUTHORIZED REPRODUCTION IS PROHIBITED

**LDM SECOND STAGE PUMP
DRAWING NO. DLC0104**

Rep. No.	Name of Part	Qty
1	Inlet Pipe	1
2	Cotter Pin	1
3	Impeller Nut	1
4	Flange O-Ring	1
5	Impeller Washer	1
6	Impeller Spacer	1
7	Stuffing Box Head	1
8	Pump Packing	10
9	Water Slinger	1
10	Impeller Shaft Oil Seal	1
11	Packing Cylinder	1
12	Gland Stud Piston	1
13	Gland Nut	1
14	Packing Screws	1
15	Impeller Shaft bearings	1
16	Impeller Shaft	1
17	Shift Collar	1
18	Pump Drive Pinion	1
19	Gear Case	1
20	Pinion Spacer	1
21	Impeller Shaft bearing	1
22	Bearing Cap Gasket	2
23	Bering Cap	1
24	Retaining Ring	4
25	Strainer Sleeve	1
26	Pipe Plug	1
27	Strainer Fitting	1
28	Inlet Pipe	1
29	Close Nipple	1
30	Inlet Flange	1
31	Seal Ring	1
32	Pump Casing	1
33	Impeller	1
34	Pump Casing Gasket	1
35	Stuffing Box Gasket	1
36	Idler Shaft bearing	2
37	Shift Bar Oil Seal	1
38	Gearcase Gasket	2
39	Idler Shaft Spacer	1
40	Idler Shaft	1
41	Alignment Pin	2
42	Idler Gear	1
43	Gearcase Spacer	1
44	Idler Gear Key	1
45	Oil Level & Fill Plug	1
46	Bearing Cap	1
47	Shift Bar O-Ring	1
48	Shift Bar	1

WARNING: DO NOT USE THIS PUMP FOR HOSE TESTING

OPERATING THE ENGINE

After the pump has been primed, the engine speed should be increased gradually -- never jerk throttle wide open. Likewise, the engine speed should be decreased gradually when shutting down.

Watch the pump pressure gage and open throttle only enough to give the desired pressure. The pressure may rise high enough to burst the discharge hose, when using small nozzles, if the engine is given full throttle (except pumps equipped with pressure regulators set for desired pressure).

Never run engine at high speeds except when pump is primed and ready to discharge water.

COOLING THE ENGINE

NFPA 1901 requires that a supplementary heat exchanger cooling system be provided. On most models, this heat exchanger is an integral part of the pump, and the installation of two hoses from the engine cooling system to the pump is all that is required.

On some models an external heat exchanger must be used. In that case two hoses from the engine cooling system and two lines from the pump will run to the heat exchanger.

The cooling line should not be opened until pressure develops in the pump, and pump should never be operated under heavy loads prolonged without an adequate supply of cooling water flowing.

Coolant temperatures should never be allowed to exceed 200° F while pumping and 180° F is usually taken as a safe operating temperature.

Always shut off cooling line when through pumping.

SUCTION STRAINERS

A large suction strainer, which will prevent the passage of a body larger than the pump impeller ports, must always be used on the free end of the suction line when pumping from draft.

The small hydrant strainer must always be inserted in the suction manifold of pump, when pumping from hydrants and at all other times except when maximum capacity is required from draft.

Failure to use a strainer at all times when pumping will cause serious trouble by clogging the pump because, even in water mains, foreign matter is invariably present, and will be drawn into pump by the high velocity of the water entering.

SUCTION LINE

The suction line of a fire pump can be the source of more operating difficulties than all the rest of the pump when working with a suction lift. Faults in the suction line which cause trouble in operation are as follows:

AIR LEAKS -- A small amount of air, expanding in the vacuum of the suction line, displaces a considerable volume of water which subtracts from the capacity that the pump is able to deliver, makes the priming difficult or causes pump to lose its prime. Therefore, it is absolutely essential to keep the suction line and the suction side of pump casing air tight at all time when drafting water.

Air leakage into pump while operating is usually indicated by a rattling sound in pump casing, miniature explosions in stream issuing from the nozzle, or by losing of prime when operating at very low capacities.

The usual cause of leaky suction lines is carelessness in handling of suction hose. Bruising of hose threads by bumping against hard surfaces or sand in the coupling often prevents tightening of the joints up against the gaskets. The hose gaskets are often defective and are sometimes lost without being noticed by the operator.

INSUFFICIENT SUBMERGENCE -- The free end of suction hose must be submerged to a sufficient depth to prevent the entrance of air that may be sucked down from the surface of the water to a considerable depth when operating at large capacities.

Entrance of air into suction lines in this manner is indicated by a small whirlpool, or vortex, on the surface of the water over the end of the hose.

A minimum submergence of 4 times the hose diameter to the upper holes in suction strainer is recommended where full capacity of pump is required. Where sufficient submergence is not possible, a board or sheet of metal laid over end of suction line will keep air from entering.

SUCTION LINE ENTRANCE TOO CLOSE TO BOTTOM -- If the end of suction line is laid on the bottom of the source of supply, a part of the suction opening will be shut off; and if the bottom is soft the hose will suck itself down into the earth, closing more of the opening and loosening sand and mud to be carried into the pump.

The suction entrance should be suspended a foot or more above the bottom, or if this is not possible, it should be laid on a board or piece of sheet metal. A rope tied to the suction strainer is a convenient means of holding it off the bottom.

OBSTRUCTION OF SUCTION STRAINER BY FOREIGN MATTER -- The high velocity of water entering the suction line will carry loose foreign bodies in against the strainer from a considerable distance. Therefore, all weeds and refuse should be removed from close proximity of the suction entrance.

SUCTION LINE TOO SMALL OR TOO LONG -- The flow of water into the pump is opposed by the frictional resistance in the suction line. This friction loss must be added to the height of the pump above the water (static lift) to determine the "total lift" of the pump. When all of the vacuum in the pump (atmospheric pressure) is consumed in raising water through this total lift, then the limit of capacity has been reached. This capacity can be increased only by decreasing total lift. If the static lift cannot be reduced, then the friction loss must be reduced by using a shorter or larger suction hose.

The rated capacity of the pump is guaranteed for a static lift of 10 feet, with 20 feet of recommended suction hose at sea level. To increase the capacity without reducing the static lift, or to increase lift without sacrificing capacity, requires larger suction hose.

An excessively long suction line is a handicap to any pump, for besides reducing capacity through the added friction loss, it retards priming and it produces a detrimental effect known as "cavitation". This means a separation of the water column in the pump suction, or void spaces, produced by the inertia of the heavy mass of water in the line resisting sudden change in the velocity when the pump starts to deliver or when discharge valves are opened or closed. This phenomenon reduces capacity further, and usually sets up a vibratory motion and "water hammer" as the water surges in and out of the void spaces.

When operating with a long suction line, the driving engine should be accelerated gradually, the discharge gates opened gradually, and the capacities of the pump should be held down to within the range of smooth performance.

AIR TRAP IN SUCTION LINE -- If the suction line is laid so that part of it is higher than any other part that is nearer to the pump, as when hose is laid over a high bridge rail, an air trap is formed at the highest part of the hose from which the air cannot be sucked out by the primer. This trapped air is expanded and carried into the pump with the first rush of water causing the pump to immediately lose its prime.

If suction line cannot be laid so that it slopes all the way from pump to water, it can still be primed easily by simply allowing the primer to continue to function until all the trapped air in the hose has been carried into the pump and picked up by the primer.

TESTING FOR AIR LEAKS

Tests for leakage should be made with the suction hose attached and capped, discharge gate open, and all other openings closed tightly.

Run electric priming pump with primer shut-off valve open, until maximum vacuum is shown on the gage. The vacuum should hold for several minutes before satisfactory performance of pump can be expected.

If excessive leakage of air occurs, the source of leaks can be located by shutting off primer motor, with vacuum at its highest point, and listening for the hiss of air.

In the absence of a vacuum gage, the vacuum in pump may be judged by closing suction opening with the flat of hand or a rubber pad.

Water or air pressure may be applied to pump casing to test for air leakage if more convenient. DO NOT pressurize with air beyond 10 PSI

SOURCE OF WATER SUPPLY

Water may be drafted from a pond, lake, stream, cistern, stock tank, or well; but whatever the source, the static lift must not exceed 20 feet from the center of the pump to the surface of the water and a lift not exceeding 10 feet is recommended. The source of supply should be reasonably clear and free from foreign matter. It is recommended that all water holes, which may be needed for fire protection, be deepened if necessary and kept free from weeds and refuse. In many fire protection areas, cisterns or reservoirs are built and allowed to fill up with rain water to be used in emergencies.

PUMPING IN COLD WEATHER

The first insurance against cold weather trouble is to keep fire apparatus stored in heated quarters. All water must be eliminated from pump casing and primer line between periods of operations.

When setting up for pumping, unnecessary delays should be avoided by having thoroughly trained pump operators. Be sure that primer and booster lines are kept closed until ready for use. Having discharge lines ready so that pump may be started as soon as it have become primed. Do not stop flow of water through the pump until ready to drain and return to the station.

Engine Coolant from the engine circulated through the heater jacket in pump casing prevents all ordinary freezing troubles.

WHEN FINISHED PUMPING

Drain water out of pump casing immediately. (Drain valve is located at lowest point in pump casing, and accessible from underneath chassis.)

Don't forget to close all drain cocks after all water has been drained out. Trouble in priming will follow on the next run if this is forgotten.

Shut off cooling line to make pump ready for priming again.

If pump transmission is equipped with a transmission cooler it must be drained also. If the master drain is located below the cooler outlets it can be connected to the master drain, if not, two separate drains must be connected to the transmission cooler. **Failure to drain transmission cooler will result in water in the gearcase if water in the cooling coil freezes.**

If pump is equipped with an external heat exchanger, drain heat exchanger using gravity and vacuum drain on all trucks as follows: Close all open lines and drain cocks. Open cooler valve and open air vent at top or drain cock at bottom of heat exchanger depending on model. With the pump air-tight open primer with engine running for about a minute and then close primer. Drain pump of water which was deposited when heat exchanger and lines were being drained.

Pump not often used for fire service should be inspected and run periodically to ensure that they will be in readiness for an emergency.

PUMPING SALT WATER

The pump should be flushed out with fresh water immediately after pumping salt water to prevent excessive rusting. (Except pumps which are built of special material to resist the corrosive action of the brine.)

When measuring sea water with a Pitot Gage, capacities shown in Table No. 2 should be discounted approximately 1 1/2% to determine the correct capacity.

A centrifugal pump will show 2 1/2% higher pressure and require 2 1/2% more power when handling sea water than when handling fresh water if operated at the same speed and capacity.

TESTING OF EQUIPMENT FOR PRACTICE

It frequently happens that operators of fire apparatus, who are not thoroughly familiar with its operations, become confused under the stress of emergency and neglect some little detail that may cause trouble or delay in getting the equipment into operation. Therefore, we urge that practice tests be conducted repeatedly until operators are thoroughly trained. More than one person in the department should be a competent operator.

Practice should include pumping from low lifts, high lifts with short and long suction lines, with suction line elevated to form an air trap, and from hydrants, at large and small capacities.

It is well, also, to note the effects of air leaks in hose, insufficient submergence and restriction of suction line. (Suction line can be restricted by placing a can or other strong closure around the suction strainer).

NEVER BREAK OR RESTRICT SUCTION OR ALLOW AIR TO ENTER SUCTION LINE WHILE ENGINE IS OPERATING WITH THROTTLE OPEN. This will release the load and allow engine to run away.

Do not allow personnel to hold a large nozzle while working at high pressures for serious accidents may result if hose breaks loose.

MEASURING PUMP PERFORMANCE

Pump performance is measured by the quantity of water it can deliver per minute against a certain pressure called "Total Head" or "Net Pump Pressure", as it is usually termed in fire pump testing.

The net pump pressure is the sum of the pump discharge pressure, as shown on the pressure gage with which the pump is regularly equipped, and the total suction lift converted to equivalent pounds per square inch. If pump is operating from a hydrant, the net pump pressure is the discharge pressure less the incoming pressure from hydrant measured at the suction entrance of pump.

Capacity of fire pump is measured in gallons per minute. The usual method of measurement is to determine the pressure of the jet of water leaving a given size of nozzle by means of a "Pitot Gage" from which the capacity is computed mathematically.

A Pitot Gage consists of a small tube adapted to a point directly into the hose nozzle from the center of the issuing stream, the other end of the tube being connected to an accurate pressure gage.

The nozzle jet drives straight into the Pitot tube and converts the velocity of the jet to pressure which is an accurate measure of velocity of the water as it leaves the nozzle. The tip of the Pitot tube should be one-half the diameter of the nozzle away from nozzle tip while taking reading. Table No. 2 gives nozzle capacities for various Pitot Gage readings.

If a Pitot gage is not available approximate pump capacities can be determined by reference to Table No.3

ACCEPTANCE TESTS

Acceptance tests require continuous tests of three hours duration: 2 hours at 100% rated capacity and 150 PSI net pump pressure; one-half hour at 70% capacity and 200 PSI; one-half hour at 50% capacity and 250 PSI; and a spurt test at 100% capacity and 165 PSI.

Table No. 1 shows recommended set-ups and gage readings for rating tests.

To adjust nozzle pressure for the correct capacity, while maintaining the correct pump pressure, it is necessary to make simultaneous adjustments of engine throttle and the discharge gate valve, partially closing the latter until just the right discharge resistance is built up.

ENGINES

An Underwriter fire pump imposes heavy loads on the engine that drives it, often absorbing all of the power the engine is capable of delivering at full throttle. Continuous pumping gives the engine no time to rest. Therefore, a new engine and pump unit must be thoroughly broken-in before it is required to deliver prolonged maximum pump performance.

We recommend a minimum break in period of 20 hours at light pumping loads, with occasional spurt tests and interruptions. Temperature and lubrication should be checked during this period.

Engine manufacturers' power ratings usually show maximum performance of a selected, factory adjusted engine, operating without fan, generator, muffler or other accessories, and corrected for "ideal" conditions, i.e. sea level barometer (29.92" of mercury) 60°F and high humidity. Therefore, the actual power delivered by an average truck mounted engine is considerably lower than the manufacturers' rating, and allowances must be made in predicting pump performance.

EFFECTS OF ATMOSPHERIC CONDITIONS ON ENGINE AND PUMP PERFORMANCE

Each one inch of drop in Barometric pressure or each 1000 feet of elevation of the pumping site reduces engine power approximately 3 1/2% for engines not equipped with a turbo charger.

Each 12° rise in temperature above 60° F of carburetor intake air reduces engine power approximately 1%.

Lowering of humidity reduces power slightly.

Each one inch drop in Barometric pressure or each 1000 feet of elevation reduces the maximum possible static lift of a pump approximately one foot.

Temperature of the water supply affects the attainable suction lift of a pump. The effect is slight at low water temperatures but becomes increasingly detrimental as the temperature rises.

A 10° rise from 70°F will subtract about 1/2 foot from the maximum attainable suction lift, while an equal rise from 100°F will reduce the lift at least 1 1/2 feet.

Temperature is an important consideration when pumping from a test pit where the water is heated by recirculation.

**IF FURTHER INFORMATION IS NEEDED, CALL W.S. DARLEY & CO. AT
CHIPPEWA FALLS, WI. AT 800-634-7812 or 715-726-2650**

DEFINITIONS

HEAD OF WATER -- vertical depth of water measured in feet or in pressure per unit or area. In hydraulics, head always represents pressure and it is expressed interchangeably in feet of water or pounds per square inch and sometimes in inches of depth of mercury.

STATIC HEAD -- the pressure that is exerted by a stationary column of water of a given height or depth.

TOTAL HEAD OR TOTAL DYNAMIC HEAD -- the maximum height above the source of supply to which the pump would elevate the water plus all the resistance to flow in the pipe or hose line.

DISCHARGE HEAD -- the pressure measured at the discharge outlet of a pump.

SUCTION HEAD -- the positive pressure measured at the suction entrance of a pump (when pumping from an elevated tank or hydrant).

VELOCITY HEAD -- the equivalent pressure represented by fluid in motion as measured by means of a Pitot Gage.

STATIC LIFT -- the vertical height of the center of the pump above the source of supply (when pump from draft).

TOTAL SUCTION LIFT -- the static lift plus the friction in suction line plus entrance losses.

NET PUMP PRESSURE -- the total dynamic head of the pump.

EFFECTIVE NOZZLE PRESSURE -- the pump discharge pressure minus hose friction plus or minus the difference in elevation above or below pump.

WATER HORSEPOWER - the theoretical power required to deliver a given quantity of water per minute against a given head.

BRAKE HORSEPOWER -- Actual power as delivered by a motor or engine to a driven machine.

PUMP EFFICIENCY -- The quotient of the water horsepower divided by brake horsepower required to produce it.

WATER HAMMER -- a series of shock waves produced in a pipeline or pump by a sudden change in water velocity. A sudden change in flow velocity can result from rapid closure of valves. A pressure wave is set up which travels back and forth in the water column at extremely high speed producing rapid vibrations that may be violent and destructive if the water column is long.

THE MAXIMUM THEORETICAL LIFT of a pump is 34 feet, which is the pressure of the atmosphere at sea level. The maximum practical total lift at sea level is 20 to 25 feet (depending on the type and condition of the pump) and this decreases with drops in barometric pressure.

OPERATING CHARACTERISTICS OF PUMPS

CENTRIFUGAL PUMPS: A centrifugal pump develops pressure by centrifugal force of the liquid rotating in the impeller wheel. The pressure developed depends upon the peripheral speed of the impeller (increasing as the square of the speed) and it remains fairly constant over a wide range of capacities up to the maximum output of the pump, if speed remains constant.

If the discharge outlet of a centrifugal pump is entirely shut off, with speed kept constant, there is a small rise in pressure, the water churns in the pump casing and the power drops to a low value. If the discharge is opened wide, with little resistance to flow the pressure drops while the capacity and power both increase to their maximum.

A centrifugal pump is an extremely simple mechanism mechanically, but rather complex hydraulically; in that many factors enter into the design of the impeller and water ways which will affect the pump's efficiency.

DISPLACEMENT PUMPS: Rotary and piston pumps are termed "Positive Displacement" pumps because each revolution displaces or discharge (theoretically) an exact amount of liquid, regardless of the resistance. The capacity is, therefore, proportional to the number of revolutions of the pump per minute and independent of the discharge pressure except as it is reduced by "slip" (leakage past the pistons or rotors). For a given speed the power is directly proportional to the head. If the discharge is completely shut off, the pressure, power, and torque climb indefinitely until the drive power is stalled or breakage occurs.

Slip is the greatest factor affecting efficiency of a displacement pump, and this factor is greatly influenced by the condition of and wears on the working parts.

**IF FURTHER INFORMATION IS NEEDED, CALL W.S. DARLEY & CO. AT
CHIPPEWA FALLS, WI. AT 800-634-7812 or 715-726-2650**

CONVERSION FACTORS

One pound per square inch	=	2.31 feet of water
	=	2.04 inches of mercury
	=	27.7 inches of water
One foot of water	=	0.43 pounds per square inch
One inch of mercury	=	1.13 feet of water
	=	0.49 pounds per square inch
One cubic foot of water	=	62.4 pounds
	=	7.5 gallons
One gallon of water	=	231 cubic inches
	=	0.13 cubic feet
	=	8.34 pounds
	=	3.8 liters
One Imperial Gallon	=	1.2 U.S. gallons
Atmospheric Pressure (Sea Level)	=	14.8 pounds per square inch
	=	29.9 inches of mercury
	=	34 feet of water

**TABLE NO. 1
NFPA 1901 TEST**

Class A							
TEST No.	GPM	Recommended Nozzles	Min. Nozzle Press. PSI	Min. Disch. Press. PSI	Min. Net Pump Press. PSI	Disch. Lines	Suction Hose
250 GPM Fire Pump							
1	250	1-1"	72	143	150	1-50"	20' of 3"
2	175	1,7/8"	62	194	200		
3	125	1,3/4"	56	244	250		
4	250	1,1"	72	158	165		
350 GPM Fire Pump							
1	350	1, 1-1/4"	58	144	150	1-50"	20' of 4"
2	245	1,1"	69	195	200		
3	175	1,7/8"	62	245	250		
4	350	1, 1-1/4"	58	159	165		
500 GPM Fire Pump							
1	500	1-1/2"	57	143	150	1-50"	20' of 4"
2	350	1-1/4"	58	194	200		
3	250	1"	72	245	250		
4	500	1-1/2"	57	158	165		
750 GPM Fire Pump							
1	750	1-3/4" or 2, 1-1/4"	68 66	142	150	2-50'	20' of 4-1/2"
2	525	1-1/2"	62	193	200	or	
3	375	1-1/4"	66	244	250	2-100'	
4	750	1-3/4" or 2, 1-1/4"	68 66	157	165	Siamesed	
1000 GPM Fire Pump							
1	1000	1, 2" or 2, 1-1/2"	71 57	142	150	2-50'	20' of 5"
2	700	1-3/4" or 2, 1-1/4"	60 58	193	200	or	
3	500	1-1/2"	57	244	250	3-100'	
4	1000	1, 2" or 2, 1-1/2"	71 57	157	165	Siamesed	
1250 GPM Fire Pump							
1	1250	2-1/4" or 2, 1-1/2"	69 88	143	150	3-50'	20' of 6"
2	875	1, 2" or 2, 1-3/8"	55 61	194	200	or	
3	625	1-1/2"	88	245	250	3-100'	
4	1250	2-1/4" or 2, 1-1/2"	69 88	158	165	and 1-50' Siamesed	

Min. discharge pressures listed above are for pumps operating with full 10' static suction lift. These pressures must be increased by 1 PSI for each 2.3 ft. less than 10' of lift.

**TABLE NO. 1
NFPA 1901 TEST**

Class A							
TEST No.	GPM	Recom-Mended Nozzles	Min. Nozzle Press. PSI	Min. Disch. Press. PSI	Min. Net Pump Press. PSI	Disch. Lines	Suction Hose
1500GPM Pump							
1	1500	2, 1-3/4" or 3, 1-1/2"	68 57	142	150	3-50'	20' of
2	1050	1, 2" or 2, 1-1/2"	78 62	194	200	or	6" Min
3	750	1, 1-3/4" or 2, 1-1/4"	68 66	245	250	3-100' and 1-50'	or (2) 20' of
4	1500	2, 1-3/4" or 3, 1-1/2"	68 57	157	165	Siamesed	6" Max
1750 GPM Pump							
1	1750	2, 2" or 3, 1-1/2"	55 76	143	150	4-50'	(2) 20' of 6"
2	1225	2, 1-5/8" or 2, 1-1/2" or 3, 1-1/4"	61 84 79	194	200	or	
3	875	1, 2" or 2, 1-3/8"	55 61	245	250	4-100'	
4	1750	2, 2" or 3, 1-1/2"	55 76	158	165		
2000 GPM Fire Pump							
1	2000	2, 2" or 4, 1-1/2"	71 57	147	150	4-50'	(2) 20' of 6"
2	1400	2, 1-3/4" or 3, 1-1/2"	60 49	199	200	or	
3	1000	1, 2" or 2, 1-1/2"	71 57	249	250	4-100'	
4	2000	2, 2" or 4, 1-1/2"	71 57	163	165		
2250 GPM Fire Pump							
1	2250	2, 2-1/4"	56	144	150	(2) 3-100'	20' of 8"
2	1575	2, 1-3/4"	76	196	200	Siamesed	
3	1125	2, 1-1/2"	72	246	250		
4	2250	2, 2-1/4"	56	153	165		

Min. discharge pressures listed above are for pumps operating with full 10' static suction lift. These pressures must be increased by 1 PSI for each 2.3 ft. less than 10' of lift.

**TABLE NO. 1
NFPA 1901 TEST**

2500 GPM Fire Pump							
1	2500	2, 2-1/4"	69	144	150	(2) 3-100' Siamesed	20' of 8"
2	1750	2, 2"	55	195	200		
3	1250	2, 1-1/2"	88	246	250		
4	2500	2, 2-1/4"	69	159	165		
3000 GPM Fire Pump							
1	3000	2, 2-1/2"	65	146	150	(2) 3-100' Siamesed	(2) 20' of 8"
2	2100	2-2"	78	196	200		
3	1500	2, 1-3/4"	68	247	250		
4	3000	2, 2-1/2"	65	161	165		
3500 GPM Industrial Fire Pump							
1	3500	2, 2-1/2" and 1, 2-1/4"	45 44	95	100	(2) 3-100' Siamesed & 2-50' Siamesed	(2) 20' of 8"
2	2450	2, 2-1/4"	67	146	150		
3	1750	2, 2"	55	197	200		

Min. discharge pressures listed above are for pumps operating with full 10' static suction lift. These pressures must be increased by 1 PSI for each 2.3 ft. less than 10' of lift.

**IF FURTHER INFORMATION IS NEEDED, CALL W.S. DARLEY & CO. AT
CHIPPEWA FALLS, WI. AT 800-634-7812 or 715-726-2650**

TABLE NO. 2
DISCHARGE FROM SMOOTH BORE NOZZLE
Pressures measured by Pitot gage.

Nozzle Pressure PSI	GALLONS PER MINUTE DELIVERED														
	1/4	3/8	1/2	5/8	3/4	7/8	1	1 1/8	1 1/4	1 3/8	1 1/2	1 5/8	1 3/4	2	2 1/4
5	4	9	16	26	37	50	66	84	103	125	149	175	203	266	337
6	4	10	18	28	41	55	72	92	113	137	163	192	223	292	369
7	4	11	19	30	44	59	78	99	122	148	176	207	241	315	399
8	5	11	21	32	47	64	84	106	131	158	188	222	257	336	427
9	5	12	22	34	50	67	89	112	139	168	200	235	273	357	452
10	6	13	23	36	53	71	93	118	146	177	211	248	288	376	477
12	6	15	25	40	58	78	102	130	160	194	231	271	315	412	522
14	7	15	27	43	63	84	110	140	173	210	249	293	340	445	564
16	7	16	29	46	67	90	118	150	185	224	267	313	364	475	603
18	7	17	31	49	71	95	125	159	196	237	283	332	386	504	640
20	8	18	33	51	75	101	132	167	206	250	298	350	407	532	674
22	8	19	34	54	79	105	139	175	216	263	313	367	427	557	707
24	8	20	36	56	82	110	145	183	226	275	327	384	446	582	739
26	9	21	37	59	85	115	151	191	235	286	340	400	464	606	769
28	9	21	39	61	89	119	157	198	244	297	353	415	481	629	799
30	10	22	40	63	92	123	162	205	253	307	365	429	498	651	826
32	10	23	41	65	95	127	167	212	261	317	377	443	514	673	854
34	11	23	43	67	98	131	172	218	269	327	389	457	530	693	880
36	11	24	44	69	100	135	177	224	277	336	400	470	546	713	905
38	11	25	45	71	103	138	182	231	285	345	411	483	561	733	930
40	11	26	46	73	106	142	187	237	292	354	422	496	575	752	954
42	11	26	47	74	109	146	192	243	299	363	432	508	589	770	978
44	12	27	49	76	111	149	196	248	306	372	442	520	603	788	1000
46	12	28	50	78	114	152	200	254	313	380	452	531	617	806	1021
48	12	28	51	80	116	156	205	259	320	388	462	543	630	824	1043
50	13	29	52	81	118	159	209	265	326	396	472	554	643	841	1065
52	13	29	53	83	121	162	213	270	333	404	481	565	656	857	1087
54	13	30	54	84	123	165	217	275	339	412	490	576	668	873	1108
56	13	30	56	86	125	168	221	280	345	419	499	586	680	889	1129
58	13	31	56	87	128	171	225	285	351	426	508	596	692	905	1149
60	14	31	57	89	130	174	229	290	357	434	517	607	704	920	1168
62	14	32	58	90	132	177	233	295	363	441	525	617	716	936	1187
64	14	32	59	92	134	180	237	299	369	448	533	627	727	951	1206
66	14	33	60	93	136	182	240	304	375	455	542	636	738	965	1224
68	14	33	60	95	138	185	244	308	381	462	550	646	750	980	1242
70	15	34	61	96	140	188	247	313	386	469	558	655	761	994	1260
72	15	34	62	97	142	191	251	318	391	475	566	665	771	1008	1278
74	15	35	63	99	144	193	254	322	397	482	574	674	782	1023	1296
76	15	35	64	100	146	196	258	326	402	488	582	683	792	1036	1313
78	15	36	65	101	148	198	261	330	407	494	589	692	803	1050	1330

TABLE NO. 2
DISCHARGE FROM SMOOTH BORE NOZZLE
Pressures measured by Pitot gage.

Nozzle Pressure PSI	1/4	3/8	1/2	5/8	3/4	7/8	1	1 1/8	1 1/4	1 3/8	1 1/2	1 5/8	1 3/4	2	2 1/4
	GALLONS PER MINUTE DELIVERED														
80	16	36	66	103	150	201	264	335	413	500	596	700	813	1063	1347
82	16	37	66	104	152	204	268	339	418	507	604	709	823	1076	1364
84	16	37	67	105	154	206	271	343	423	513	611	718	833	1089	1380
86	16	37	68	107	155	208	274	347	428	519	618	726	843	1102	1396
88	16	38	69	108	157	211	277	351	433	525	626	735	853	1115	1412
90	17	39	70	109	159	213	280	355	438	531	633	743	862	1128	1429
92	17	39	70	110	161	215	283	359	443	537	640	751	872	1140	1445
94	17	39	71	111	162	218	286	363	447	543	647	759	881	1152	1460
96	17	40	72	113	164	220	289	367	452	549	654	767	890	1164	1476
98	17	40	73	114	166	223	292	370	456	554	660	775	900	1176	1491
100	18	41	73	115	168	225	295	374	461	560	667	783	909	1189	1506
105	18	42	75	118	172	230	303	383	473	574	683	803	932	1218	1542
110	19	43	77	121	176	236	310	392	484	588	699	822	954	1247	1579
115	19	43	79	123	180	241	317	401	495	600	715	840	975	1275	1615
120	19	44	80	126	183	246	324	410	505	613	730	858	996	1303	1649
125	20	45	82	129	187	251	331	418	516	626	745	876	1016	1329	1683
130	20	46	84	131	191	256	337	427	526	638	760	893	1036	1356	1717
135	21	47	85	134	195	262	343	435	536	650	775	910	1056	1382	1750
140	21	48	87	136	198	266	350	443	546	662	789	927	1076	1407	1780
145	21	49	88	139	202	271	356	450	556	674	803	944	1095	1432	1812
150	22	50	90	141	205	275	362	458	565	686	817	960	1114	1456	1843

TABLE NO. 3
Approximate Discharge Flow From Different Nozzles
At the end of Fifty Feet of Average, 2 1/2"
Rubber Lined Fire Hose, for Various
Pump Pressures with Discharge
Valve Wide Open

PUMP PRESSURE LBS	SIZE OF NOZZLE & GALLONS PER MINUTE						
	3/4	7/8	1	1 1/8	1 1/4	1 3/8	1 1/2
30	90	119	153	187	217	250	282
40	103	137	177	216	253	290	327
50	115	153	198	242	284	325	367
60	126	168	216	265	311	357	402
70	136	182	234	287	337	385	435
80	145	194	250	308	361	414	465
90	154	206	265	325	383	437	492
100	162	217	280	343	405	462	520
110	171	228	295	360	425	485	549
120	179	239	307	377	444	510	572
130	186	249	318	392	462	530	596
140	193	258	330	407	480	549	618
150	200	267	341	421	497	567	
175	215	288	374	455	538		
200	230	309	395	486			
225	243	328	420				
250	257	345					

This table is offered as an aide in testing pump performance where facilities for accurate measurement of capacity are not available. The capacities given above are conservative, and will not vary more than 5% from actual capacities with any of the standard hose that might be used.

TABLE NO. 4

Pump or Hydrant Pressure required to give Effective Nozzle Pressure through various Lengths of Rubber Lined Hose.

Size of Hose		1		1 1/2		2		2 1/2				3		
Size of Nozzle		1/4	3/8	1/2	5/8	5/8	3/4	3/4	7/8	1	1 1/4	1 1/2	1 1/4	1 1/2
Nozzle Press PSI	Length of Hose Feet	PUMP OR HYDRANT PRESSURE - PSI												
40	100	45	43	48	60	42	50	44	46	51	64	88	51	62
	200	49	46	56	79	43	60	47	52	60	86	130	59	78
	400	58	51	73	118	46	79	53	62	79	129	212	75	110
	600	67	57	89	158	50	99	59	74	97	172		92	143
	800	76	62	106	196	53	119	65	85	116	215		108	176
	1000	85	68	122	235	56	138	72	96	134	258		124	208
	1500	108	72	142		64	187	87	118	181			165	
60	2000	130	96	204		72	226	103	227				205	
	100	67	64	72	89	63	73	65	69	75	95	132	76	92
	200	74	68	84	117	65	86	70	78	89	126	196	88	115
	400	87	76	107	173	69	112	79	94	116	188		111	161
	600	101	85	131	231	74	138	88	111	143	250		135	208
	800	114	93	153		79	164	98	127	170			158	
	1000	127	101	178		83	190	107	143	197			182	
80	1500	161	122	237		95	155	130	184	264				
	2000	195	142			106		153	225					
	100	88	85	96	117	83	99	87	92	99	126	175	101	103
	200	97	91	112	154	86	117	93	103	115	167		116	154
	400	115	102	143	228	92	154	105	125	148	249		147	
	600	132	112	174		98	191	117	147	181			178	
	800	150	123	206		104	228	129	167	214			209	
100	1000	167	134	238		110		141	191	247				
	1500	211	161			125		171	245					
	2000	254	188			140		201						
	100	111	107	120	146	104	123	108	115	125	157		126	152
	200	122	113	139	192	108	145	116	128	150	209		146	190

	400	143	127	17 7	284	115	190	130	15 4	20 0			184	
	600	165	140	21 7		123	235	145	18 0	25 0			223	
	800	186	154	25 6		131		159	20 6					
	1000	208	167			138		174	23 2					
	1500	262	200			157		211						
	2000		234			175		253						

**TABLE NO. 5
REACH OF FIRE STREAMS**

Size of Nozzle	1/4"	3/8"	1/2"	5/8"	3/4"	7/8"	1"	1-1/4"	1-1/2"
-----------------------	-------------	-------------	-------------	-------------	-------------	-------------	-----------	---------------	---------------

NOZZLE

PRESSURE EFFECTIVE VERTICAL REACH - Feet

40	30	35	40	50	59	62	64	65	69
60	35	40	45	60	74	77	79	84	87
80	38	42	48	65	81	85	89	94	96
100	40	44	50	68	84	89	94	100	102

NOZZLE

PRESSURE MAXIMUM VERTICAL REACH - Feet

40	60	65	70	75	78	79	80	80	80
60	70	75	85	95	105	106	108	110	110
80	78	83	95	105	117	125	132	140	140
100	80	88	100	110	122	135	145	155	155

NOZZLE

PRESSURE EFFECTIVE HORIZONTAL REACH - Feet

40	20	25	30	40	44	50	55	62	66
60	25	32	37	50	54	61	67	75	80
80	28	35	40	57	62	70	76	84	88
100	30	37	42	60	66	76	84	93	95

NOZZLE

PRESSURE MAXIMUM HORIZONTAL REACH - Feet

40	65	80	90	100	108	120	125	138	140
60	80	95	95	120	127	142	156	176	183
80	90	105	105	135	143	160	175	201	210
100	95	110	110	140	153	180	205	215	223

TABLE NO. 6
Friction Loss in Fire Hose
 Loss in PSI per 100 Feet of Hose

SIZE HOSE G.P.M.	LINEN HOSE			BEST RUBER LINED HOSE							
	1 1/2	2	2 1/2	3/4	1	1 1/2	2	2 1/2	3	3 1/2	(2)-2 1/2
10	1.0			13.5	3.5	0.5	.1				
15	2.2			29.0	7.2	1.0	0.3				
20	3.6			50.0	12.3	1.7	0.4				
25	5.5			75.0	18.5	2.6	0.6				
30	8.0	1.9		105.0	26.0	3.6	0.9				
40	13.0	3.2		180.0	44.0	6.1	1.5				
50	20.0	4.9	1.6		67.0	9.3	2.3				
60	28.0	7.0	2.2		96.0	13.5	3.3				
70	37.0	9.0	3.1		131.0	17.0	4.3				
80	47.0	11.5	3.8		171.0	23.0	5.6				
90	59.0	14.5	5.0		217.0	29.0	7.0				
100	72.0	17.5	5.9		268.0	33.0	8.4				
120		25.0	8.3		386.0	47.0	11.7				
140		34.0	11.0			62.0	16.0	5.2	2.0	0.9	1.4
160		43.0	14.0			78.0	20.0	6.6	2.6	1.2	1.9
180		53.0	17.7			97.0	25.0	8.3	3.2	1.5	2.3
200		63.0	21.5			121.0	30.6	10.1	3.9	1.8	2.8
220						146.0		12.0	4.6	2.1	3.3
240						173.0		14.1	5.4	2.5	3.9
260						204.0		16.4	6.3	2.9	4.5
280						237.0		18.7	7.2	3.3	5.2
300						272.0		21.2	8.2	3.7	5.9
320								23.8	9.3	4.2	6.6
340								26.9	10.5	4.7	7.4
360								30.0	11.5	5.2	8.3
380								33.0	12.8	5.8	9.2
400								36.2	14.1	6.3	10.1
425								40.8	15.7	7.0	11.3
450								45.2	17.5	7.9	12.5
475								50.0	19.3	8.7	13.8
500								55.0	21.2	9.5	15.2
525									23.2	10.5	16.6
550									25.2	11.4	18.1
575									27.5	12.4	19.6
600									29.9	13.4	21.2
650									34.5	15.5	24.8
700									39.5	17.7	28.3
750									45.0	20.1	32.2
800									50.5	22.7	36.2
850									56.5	25.4	40.7
900									63.0	28.2	45.2
1000									76.5	34.3	55.0

Losses in rough walled, rubber hose may be 50% higher than values given above.

TABLE NO. 7
Friction Loss in 15-year-old Steel Pipe
 Loss in PSI per 100 Feet of Pipe

PIPE SIZE G.P.M.	1/8	1/4	3/8	1/2	3/4	1	1 1/4	1 1/2	2	2 1/2	3	4	6	8
1	52.0	12.0	2.8	0.9										
2		45.0	10.0	3.2	4.0									
5			55.0	18.0	4.5	1.4	0.4							
10				64.0	16.0	5.0	1.3	0.6						
15				135.0	34.0	11.0	2.7	1.3	0.5					
20					59.0	18.0	4.7	2.2	0.8					
25					89.0	27.0	7.1	3.4	1.2					
30					125.0	39.0	10.0	4.7	1.7	0.6				
35						51.0	13.0	6.3	2.2	0.7				
40						66.0	17.0	8.0	2.9	0.9				
45						82.0	21.0	10.0	3.6	1.2				
50						99.0	26.0	12.0	4.3	1.4	0.6			
60						140.0	38.0	17.0	6.1	2.0	0.8			
70							49.0	23.0	8.0	2.7	1.1			
80							63.0	29.0	10.0	3.4	1.5			
90							78.0	36.0	13.0	4.3	1.8			
100							96.0	44.0	15.0	5.1	2.2	0.5		
125							144.0	66.0	24.0	7.8	3.3	0.8		
150								93.0	33.0	11.0	4.6	1.1		
175								125.0	44.0	15.0	6.1	1.5		
200									56.0	19.0	7.8	1.9		
250									84.0	28.0	12.0	2.9		
300									114.0	40.0	16.0	4.0	0.6	
350										53.0	22.0	5.4	0.8	
400										68.0	28.0	6.9	1.0	
450										84.0	35.0	8.6	1.2	
500										102.0	42.0	10.0	1.4	0.4
600											60.0	15.0	2.1	0.6
800												25.0	3.5	1
1000												37.0	5.2	1.3
1500													11.0	2.7
2000													19.0	4.7
2500													29.0	7.1
3000														10

TABLE NO. 8
Resistance of Fittings
Equivalent Lengths of Straight Pipe - Feet

PIPE SIZE	1/2	3/4	1	1 1/4	1 1/2	2	2 1/2	3	4	5	6	8
Gate Valve	0.4	0.6	0.8	1.1	1.4	1.8	2.2	2.8	4.1	5.3	6.7	9.4
Global Valve	3.0	4.5	6.0	8.5	10.5	14.0	17.0	22.0	32.0	42.0	53.0	75.0
Angle Valve	1.4	2.0	2.7	3.8	4.8	6.3	7.9	10.5	14.5	18.5	23.0	33.0
Std. Elbow	1.1	1.5	2.0	2.8	3.5	4.7	5.8	7.5	11.0	14.0	18.0	24.0
45 Elbow	0.6	0.8	1.0	1.4	1.6	2.1	2.5	3.1	4.2	5.2	6.3	8.5
Long Sweep El Str Run Tee	0.5	0.8	1.0	1.4	1.7	2.3	2.8	3.7	5.3	7.0	9.0	12.5
Std. Tee Thru Side Outlet	2.1	2.9	3.9	5.5	6.9	9.1	11.6	14.8	21.0	27.0	34.0	49.0
Sudden Enlarg or contraction	1.8	2.5	3.2	4.2	5.0	6.5	7.5	9.5	13.0	16.0	19.0	25.0
Entrance to Pipe	1.0	1.3	1.6	2.2	2.6	3.3	3.9	4.9	6.5	8.2	10.0	13.0

TABLE NO. 9
To Convert Pounds per Square Inch to
Feet Elevation of Water

Feet	5	10	15	20	25	30	35	40	45	50	60	70	80	90
Pounds	2.2	4.3	6.5	8.7	11	13	15	17	20	22	26	30	35	39
Feet	100	120	130	140	150	160	170	180	190	200	220	240	260	280
Pounds	43	52	56	61	65	69	74	78	82	87	95	104	113	121
Feet	300	320	340	360	380	400	425	450	475	500	525	550	600	700
Pounds	130	139	147	156	165	173	184	195	206	217	227	238	260	303

Table NO. 10
American National Fire Hose Connection Screw Thread - NH

Size of Hose	3/4	1	1 1/2	2 1/2	3	3 1/2	4	4 1/2	5	6
Thr'ds per inch	8	8	9	7.5	6	6	4	4	4	4
Thread Designation	0.75-8 NH	1-8 NH	1.5-9 NH	2.5-7.5 NH	3-6 NH	3.5-6 NH	4-4 NH	4.5-4 NH	5-4 NH	6-4 NH
Max. O.D. Male	1.3750	1.3750	1.9900	3.0686	3.6239	4.2439	5.0109	5.7609	6.2600	7.0250

Ref. NFPA 1963

Underwriters Nozzle Tip Thread: 2.1875 O.D. - 12 threads per inch.

IF FURTHER INFORMATION IS NEEDED, CALL W.S. DARLEY & CO. AT
CHIPPEWA FALLS, WI. AT 800-634-7812 or 715-726-2650

W.S. DARLEY & CO.

OPERATING INSTRUCTIONS - ELECTRIC PRIMING PUMP

The Darley electric primer will develop up to 25 in. Hg. in an air tight pumping system.

The Primer is activated by a combination spring return on-off valve and electric switch. Pulling the valve out opens the valve and closes the electrical circuit to start the motor.

Before the pump can be primed, booster line valves, drain valves, cooling line valve, and all other openings into the pump must be closed and absolutely air tight. The discharge side of the pump is sealed by a check valve, therefore the main discharge valves need not be closed.

When operating from draft, suction hose connections must be tight and free of air leaks.

Make certain the suction hose strainer is properly submerged and free of foreign material.

The main pump drive should remain disengaged until priming is complete to prevent possible damage to impeller seal rings by running "dry".

Pull the primer shutoff valve all the way out to start priming and hold open until water discharges from primer pump exhaust port. Push valve all the way in to shut off primer motor and seal tight.



CAUTION: FOR PRIMING UP TO 10' OF LIFT:

If water does not discharge from the primer exhaust within about 30 seconds (45 seconds with 2 – 20' lengths of hose) stop the primer pump, check for air leaks and make sure primer pump is receiving lubricant from its reservoir, if one is present. **MAX PRIMER OPERATION TIME = 90 seconds every 5 minutes. DO NOT EXCEED 90 SECONDS OF PRIMER OPERATION.**



CAUTION: FOR PRIMING 10' OF LIFT AND HIGHER:

If water does not discharge from the primer exhaust within 90 seconds stop the primer pump, check for air leaks and make sure primer pump is receiving lubricant from its reservoir, if one is present. **DO NOT EXCEED 90 SECONDS OF PRIMER OPERATION.**



CAUTION: The primer pump and motor will begin to generate heat as soon as operation begins. Extended run times (up to 90 seconds) and repeating priming cycles consecutively or within short time periods may lead to premature failure of the primer pump assembly: such failures include but are not limited to: overheating of the motor, seizure of the rotor, and cracking of primer vanes. To avoid this, after your first priming attempt, thoroughly inspect the pump system for air leaks, check that the primer is

receiving lubricant from its reservoir if such is present, and resolve the issue before attempting re-prime.

Engage “Pump” shift to start pumping water.

When pumping from hydrants, the primer is not needed and must be kept closed.

It may be necessary to use the primer momentarily when pumping from a booster tank when the suction head is insufficient to force all the air out of the pump.

LUBRICATING SYSTEM - ELECTRIC PRIMING PUMPS WITH FLUID RESERVOIR

The electric motor rotary van primer pump creates a high vacuum by continuous lubrication of rotor and vanes. Therefore the primer lubricant supply tanks (4 quarts) should be kept full at all times. Recommended primer system lubricant is Darley PRIME GREEN. PRIME GREEN is an environmentally safe, non-toxic, biodegradable lubricant. Its use assures proper primer vane lubricant while minimizing environmental effects.

After the main pump is drained, run the primer motor to drain primer lines and re-lubricate the primer pump.

The vent hole on the lubricant tank cap should be kept open at all times to prevent siphoning lubricant from the tank after the pump is stopped. Do not increase the size of the hole.

Locate the lubricant tank where it may be conveniently inspected and filled.

Should water appear in the lubricant supply tank, the primer valve is leaking. Check and replace valve plug seal o-ring if necessary.

ELECTRIC PRIMING PUMPS WITHOUT FLUID RESERVOIR

The fluidless electric-motor rotary-vane primer pump creates a high vacuum by using a special material for the vanes and an initial factory applied lubricant film. This film must be present in order for the primer to operate properly and to provide maximum life for the primer components.

This film should not wash away completely if the pump is used to pump clean water. If the priming pump is disassembled for any reason, all internal surfaces of the housing and end caps must be cleaned and coated completely with Dow Corning #111 Silicone valve lubricant prior to operating the primer. If a degradation of performance is noticed, performance may be restored by re-applying the film in this manner. It is recommended to service the primer annually to clean and re-apply the silicone film to the inside of the primer housing and end caps. Do not apply grease to the rotor slots, or the sides of the vanes.

After the main pump is drained, run the primer motor to drain primer lines.

AN	DESCRIPTION	PART NO.	QTY.
1	ASSEMBLY - PRIMER, MOTOR	4220105	1
2	BEARING - OILITE, 0.625 ID	1760023	2
3	COUPLING - 844093	2404500	1
4	CYLINDER - VACUUM PUMP	020800	1
5	HEAD - CYLINDER INBOARD	200800	1
6	HEAD - CYLINDER, OUTBOARD	200800	1
7	SHIMS - .313-18 X 1.00 SST	540610	4
8	KEY - .50, 0.19 X 0.62 GR2	3602425	1
9	KEY - WOODRUFF, .606	3602200	1
10	MOTOR - PRIMER, 12V	4223400	1
11	NUT - HEX, .313-15, SST	5403024	2
12	O-RING - 3.50 X 3.69 X 0.69	3801101	2
13	OIL SEAL - 0.625 ID X 1.128 OD	3800305	1
14	PLUG - PIPE, 0.250, BR, 50, 10	080504	1
15	STRAP - GROUND, 12V PRIMER	080516	1
16	WASHER - FLAT, 5/16, STEEL	3403802	2
17	WASHER - LOCK, 0.313 ID	3403502	6

REVISIONS		REV. NO.	DATE
1	REVISED FOR USER	001	08/01/00
2	REVISED FOR USER	002	08/01/00
3	REVISED FOR USER	003	08/01/00

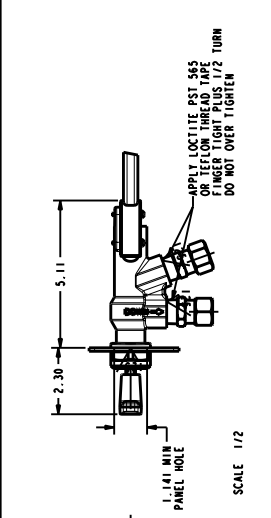
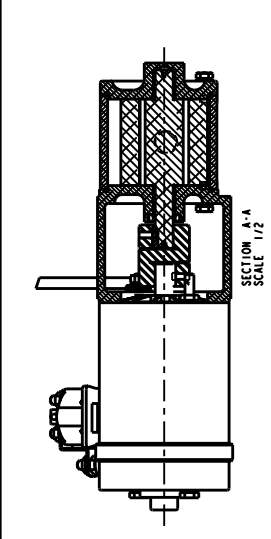

NOTE:
 - FOR CROSS SECTION AND EXPLODED VIEW DRAWING SEE OVERALL DIMENSIONS & DIMENSIONS OF THIS VALVE WITH THIS NEW VERSION. BUSHING 7162500 CAN BE USED TO RETROFIT IT TO THE EXISTING PANEL.

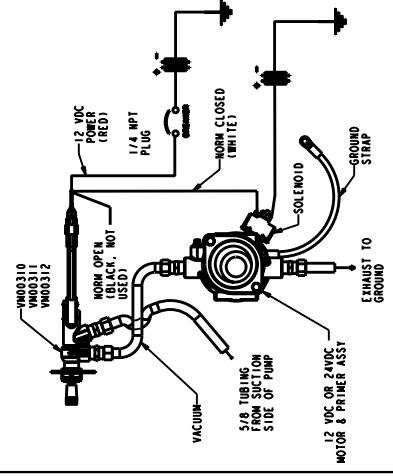
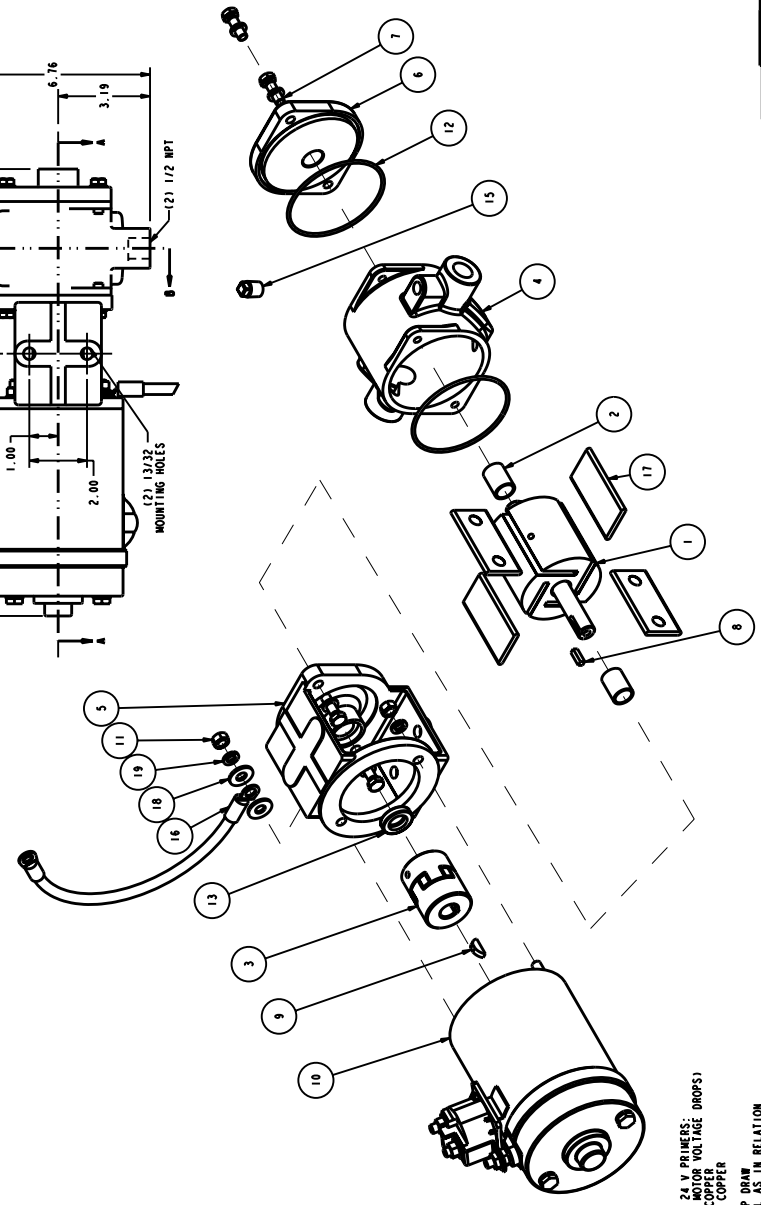

NOTE:
 MOUNT WITH EXHAUST OUTLET DOWN
 TO CLEAN, PAINT FREE GROUNDING SURFACE
 IF SUPPLIED GROUND STRAP IS REMOVED FROM ASSEMBLY, RETIGHTEN CYLINDER HEAD ADAPTER TO 90 IN. LB.

POSITIVE LEAD WIRE SIZES FOR 12 V & 24 V PRIMERS:
 0 - 10 AMP STANDARD (12V), 0 - 12 AMP COPPER (VOLTAGE DROPS)
 0 - 10 AMP (12V), 0 - 12 AMP COPPER
 0 - 10 AMP (12V), 0 - 12 AMP COPPER

THESE GAGE WIRES CORRESPOND WITH AMP DRAW REQUIREMENTS FOR GIVEN WIRE AS WELL AS IN RELATION TO RESISTANCE OVER GIVEN LENGTH.
 12 V = 240 AMP
 24 V = 140 AMP

WEIGHT = 27 LB (12.1 KG)

REV. NO.	DATE	BY	CHKD BY	APP'D BY
001	08/01/00			
002	08/01/00			
003	08/01/00			

INCH DIMENSIONS
 REMOVE SHARP EDGES
 PARTS BELONG TO THE PROPERTY OF THE MANUFACTURER
 DO NOT SCALE PRINT

DATE: 10-04-08
 DRAWING NO.: DVC0207

NO.	DESCRIPTION	PART NO.	QTY.
1	ASSEMBLY - PRIMER, MOTOR	425105	1
2	BEARING - OILITE, 0.625 ID	176023	2
3	COUPLING - 844093	2404500	1
4	CYLINDER - VACUUM PUMP	1024800	1
5	HEAD - CYLINDER IMBOARD	2009004	1
6	HEAD - CYLINDER, OUTBOARD	2009800	1
7	NUCS - 313-18 X 1.00, SST	5408610	4
8	KEY - SO. 0.19 X 0.62 GR2	3602425	1
9	KEY - WOODRUFF, 606	3602200	1
10	MOTOR - PRIMER, 24V	4225500	1
11	MUT - MET. 313-15, SST	5403024	2
12	O-RING - 3.50 X 3.69 X 0.09	3601101	2
13	OIL SEAL - 0.625 ID X 1.128 OD	3600905	1
14	TUBE FITTING - STR. .25 X .19	3300021	1
15	STRAP - GROUND, 12V PRIMER	2600516	1
16	WASHER - FLAT, 5/16, STEEL	4407640	4
17	WASHER - LOCK, 0.313 ID	3603502	2
18	WASHER - LOCK, 0.313 ID	3603502	2
19	WASHER - LOCK, 0.313 ID	3603502	2
20	WASHER - LOCK, 0.313 ID	3603502	2
21	WASHER - LOCK, 0.313 ID	3603502	2
22	WASHER - LOCK, 0.313 ID	3603502	2
23	WASHER - LOCK, 0.313 ID	3603502	2
24	WASHER - LOCK, 0.313 ID	3603502	2
25	WASHER - LOCK, 0.313 ID	3603502	2
26	WASHER - LOCK, 0.313 ID	3603502	2
27	WASHER - LOCK, 0.313 ID	3603502	2
28	WASHER - LOCK, 0.313 ID	3603502	2
29	WASHER - LOCK, 0.313 ID	3603502	2
30	WASHER - LOCK, 0.313 ID	3603502	2
31	WASHER - LOCK, 0.313 ID	3603502	2
32	WASHER - LOCK, 0.313 ID	3603502	2
33	WASHER - LOCK, 0.313 ID	3603502	2
34	WASHER - LOCK, 0.313 ID	3603502	2
35	WASHER - LOCK, 0.313 ID	3603502	2
36	WASHER - LOCK, 0.313 ID	3603502	2
37	WASHER - LOCK, 0.313 ID	3603502	2
38	WASHER - LOCK, 0.313 ID	3603502	2
39	WASHER - LOCK, 0.313 ID	3603502	2
40	WASHER - LOCK, 0.313 ID	3603502	2
41	WASHER - LOCK, 0.313 ID	3603502	2
42	WASHER - LOCK, 0.313 ID	3603502	2
43	WASHER - LOCK, 0.313 ID	3603502	2
44	WASHER - LOCK, 0.313 ID	3603502	2
45	WASHER - LOCK, 0.313 ID	3603502	2
46	WASHER - LOCK, 0.313 ID	3603502	2
47	WASHER - LOCK, 0.313 ID	3603502	2
48	WASHER - LOCK, 0.313 ID	3603502	2
49	WASHER - LOCK, 0.313 ID	3603502	2
50	WASHER - LOCK, 0.313 ID	3603502	2
51	WASHER - LOCK, 0.313 ID	3603502	2
52	WASHER - LOCK, 0.313 ID	3603502	2
53	WASHER - LOCK, 0.313 ID	3603502	2
54	WASHER - LOCK, 0.313 ID	3603502	2
55	WASHER - LOCK, 0.313 ID	3603502	2
56	WASHER - LOCK, 0.313 ID	3603502	2
57	WASHER - LOCK, 0.313 ID	3603502	2
58	WASHER - LOCK, 0.313 ID	3603502	2
59	WASHER - LOCK, 0.313 ID	3603502	2
60	WASHER - LOCK, 0.313 ID	3603502	2
61	WASHER - LOCK, 0.313 ID	3603502	2
62	WASHER - LOCK, 0.313 ID	3603502	2
63	WASHER - LOCK, 0.313 ID	3603502	2
64	WASHER - LOCK, 0.313 ID	3603502	2
65	WASHER - LOCK, 0.313 ID	3603502	2
66	WASHER - LOCK, 0.313 ID	3603502	2
67	WASHER - LOCK, 0.313 ID	3603502	2
68	WASHER - LOCK, 0.313 ID	3603502	2
69	WASHER - LOCK, 0.313 ID	3603502	2
70	WASHER - LOCK, 0.313 ID	3603502	2
71	WASHER - LOCK, 0.313 ID	3603502	2
72	WASHER - LOCK, 0.313 ID	3603502	2
73	WASHER - LOCK, 0.313 ID	3603502	2
74	WASHER - LOCK, 0.313 ID	3603502	2
75	WASHER - LOCK, 0.313 ID	3603502	2
76	WASHER - LOCK, 0.313 ID	3603502	2
77	WASHER - LOCK, 0.313 ID	3603502	2
78	WASHER - LOCK, 0.313 ID	3603502	2
79	WASHER - LOCK, 0.313 ID	3603502	2
80	WASHER - LOCK, 0.313 ID	3603502	2
81	WASHER - LOCK, 0.313 ID	3603502	2
82	WASHER - LOCK, 0.313 ID	3603502	2
83	WASHER - LOCK, 0.313 ID	3603502	2
84	WASHER - LOCK, 0.313 ID	3603502	2
85	WASHER - LOCK, 0.313 ID	3603502	2
86	WASHER - LOCK, 0.313 ID	3603502	2
87	WASHER - LOCK, 0.313 ID	3603502	2
88	WASHER - LOCK, 0.313 ID	3603502	2
89	WASHER - LOCK, 0.313 ID	3603502	2
90	WASHER - LOCK, 0.313 ID	3603502	2
91	WASHER - LOCK, 0.313 ID	3603502	2
92	WASHER - LOCK, 0.313 ID	3603502	2
93	WASHER - LOCK, 0.313 ID	3603502	2
94	WASHER - LOCK, 0.313 ID	3603502	2
95	WASHER - LOCK, 0.313 ID	3603502	2
96	WASHER - LOCK, 0.313 ID	3603502	2
97	WASHER - LOCK, 0.313 ID	3603502	2
98	WASHER - LOCK, 0.313 ID	3603502	2
99	WASHER - LOCK, 0.313 ID	3603502	2
100	WASHER - LOCK, 0.313 ID	3603502	2

REVISIONS

NO.	DESCRIPTION	DATE	BY	CHKD.	APP.
1	REVISED FOR USE				

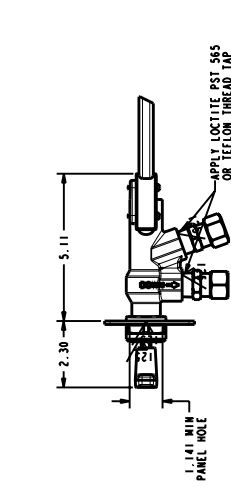
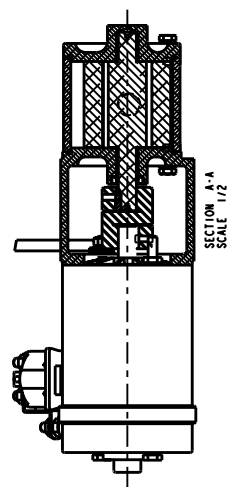

NOTE:
 FOR CROSS SECTION AND EXPLODED VIEW DRAWING
 SEE DRAWING DVC0203
 ALSO, WHEN REPLACING THE OLD VERSION OF THIS VALVE WITH
 THE NEW VERSION, PART NUMBER 1762500 CAN BE USED TO RETROFIT
 IT TO THE EXISTING PANEL.

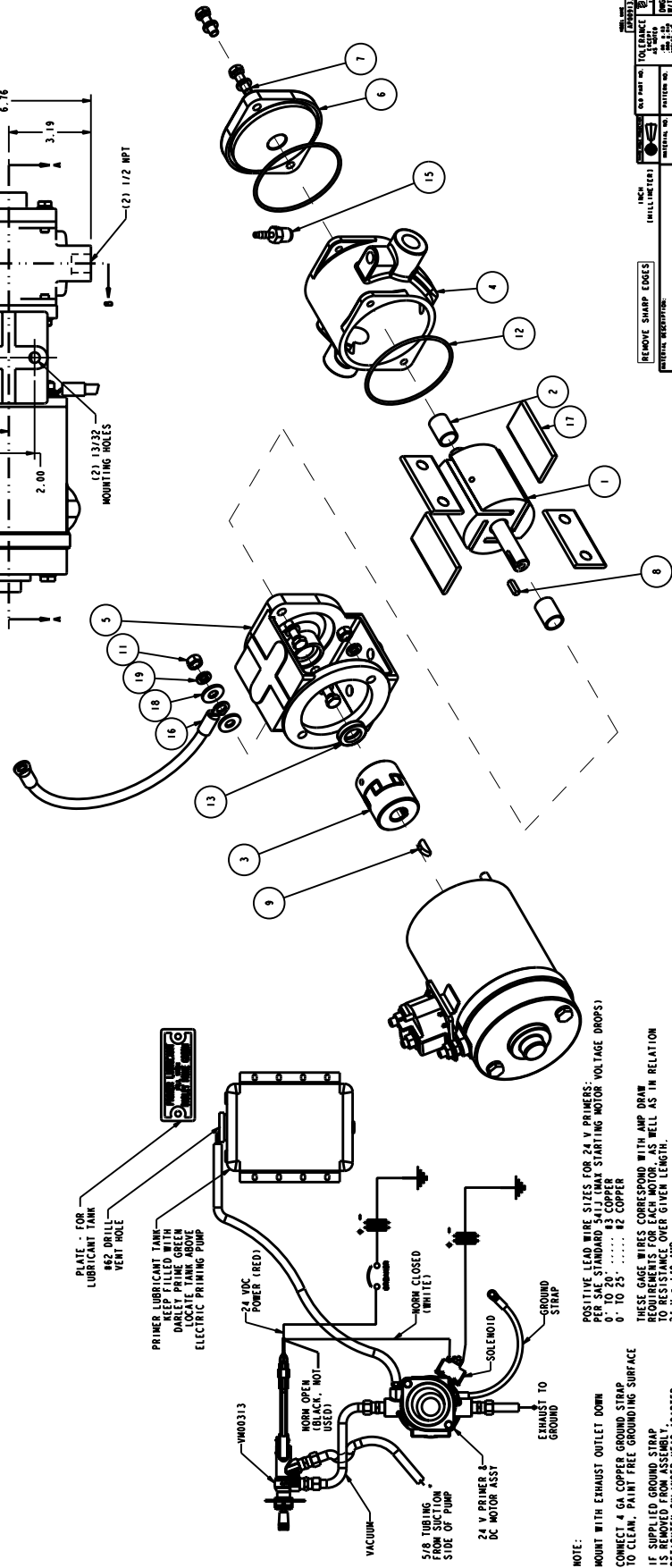

NOTE:
 MOUNT WITH EXHAUST OUTLET DOWN
 CONNECT 4 GA COPPER GROUND STRAP
 TO CLEAN, PAINT FREE GROUNDING SURFACE
 IF SUPPLIED GROUND STRAP
 RETIGHTEN CYLINDER HEAD ADAPTER
 RETAINING NUTS EQUALLY
 TO 90 IN. LB.

POSITIVE LEAD WIRE SIZES FOR 24 V PRIMERS:
 PER SAE STANDARD 541J (MAX STARTING MOTOR VOLTAGE DROPS)
 0 TO 20' #3 COPPER
 0 TO 25' #2 COPPER

THESE GAGE WIRES CORRESPOND WITH AMP DRAW
 REQUIREMENTS FOR EACH MOTOR, AS WELL AS IN RELATION
 TO 24 V = 140 AMP

WEIGHT : 27 LB (12.1 KG)

REMOVE SHARP EDGES

INCH MILLIMETERS

DO NOT SCALE PRINT

DVC0209

W.S. DARLEY & CO.

OPERATING INSTRUCTIONS - ELECTRIC PRIMING PUMP

PUSH BUTTON ELECTRIC ACTUATED VALVE

The Darley electric primer will develop up to 25 in. Hg. in an air tight pumping system.

The Primer is activated by a push button, 0.8 second cycle time, electric-actuated valve. This valve has three wires: ground (black), +12 or +24 VDC constant power (red), and +12 or +24 VDC energizing power (white). The valve has two internal micro-switches that cut the power to the valve when it is either fully closed or fully open. The push button is a simple SPST switch, that bypasses the red (constant power) wire with the white wire and energizes the valve to the open position when it is pushed; and cuts power to the white wire and resumes power to the red wire, closing the valve when it is released. When the button is pushed, the circuit for the primer motor is also completed, priming will begin instantaneously, and likewise when the button is released, the primer motor will shut off instantaneously.

Before the pump can be primed, booster line valves, drain valves, cooling line valve, and all other openings into the pump must be closed and absolutely air tight. The discharge side of the pump is sealed by a check valve; therefore the main discharge valves need not be closed.

When operating from draft, suction hose connections must be tight and free of air leaks.

Make certain the suction hose strainer is properly submerged and free of foreign material.

The main pump drive should remain disengaged until priming is complete to prevent possible damage to impeller seal rings by running "dry".

Push the primer/valve activation button, located on your control panel, and hold until water discharges from primer pump exhaust port.

If water does not discharge from primer exhaust within about 30 seconds (45 seconds with 2-20' lengths) stop primer pump, check for air leaks and make sure primer pump is receiving lubricant from its reservoir.

NOTE: Do not run the primer for more than one minute; it will burn up the motor, if prime is not reached within one minute, repeat the steps above.

Engage "Pump" shift to start pumping water.

When pumping from hydrants, the primer is not needed and must be kept closed.

It may be necessary to use the primer momentarily when pumping from a booster tank when the suction head is insufficient to force all the air out of the pump.

LUBRICATING SYSTEM - ELECTRIC PRIMING PUMPS WITH FLUID RESERVOIR

The electric motor rotary vane primer pump creates a high vacuum by continuous lubrication of rotor and vanes. Therefore the primer lubricant supply tanks (4 quarts) should be kept full at all times. Recommended primer system lubricant is Darley PRIME GREEN. PRIME GREEN is an environmentally safe, non-toxic, biodegradable lubricant. Its use assures proper primer vane lubricant while minimizing environmental effects.

After the main pump is drained, run the primer motor to drain primer lines and re-lubricate the primer pump.

The vent hole on the lubricant tank cap should be kept open at all times to prevent siphoning lubricant from the tank after the pump is stopped. Do not increase the size of the hole.

Locate the lubricant tank where it may be conveniently inspected and filled.

Should water appear in the lubricant supply tank, the primer valve is leaking. Check and replace valve plug seal o-ring if necessary.

ELECTRIC PRIMING PUMPS WITHOUT FLUID RESERVOIR

The fluidless electric-motor rotary-vane primer pump creates a high vacuum by using a special material for the vanes and an initial factory applied lubricant film. This film must be present in order for the primer to operate properly and to provide maximum life for the primer components.

This film will not wash away completely if the pump is used to pump water. If the priming pump is disassembled for any reason, all internal surfaces of the housing and end caps must be coated completely with Dow Corning #111 Silicone valve lubricant prior to operating the primer. If after several years, a degradation of performance is noticed, performance may be restored by re-applying the film in this manner.

After the main pump is drained, run the primer motor to drain primer lines.

REVISIONS			
LTR	DESCRIPTION	DATE	CHG NO. APPR'D

SUPPLIED BY KZCO

White: Switched 12 VDC (+) = Relay Energized "OPEN"
 Black: Constant 12 VDC (-)
 Red: Constant 12 VDC (+)

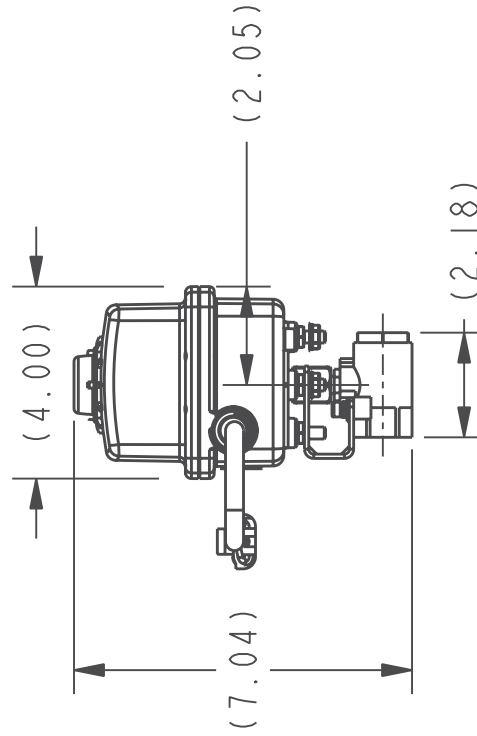
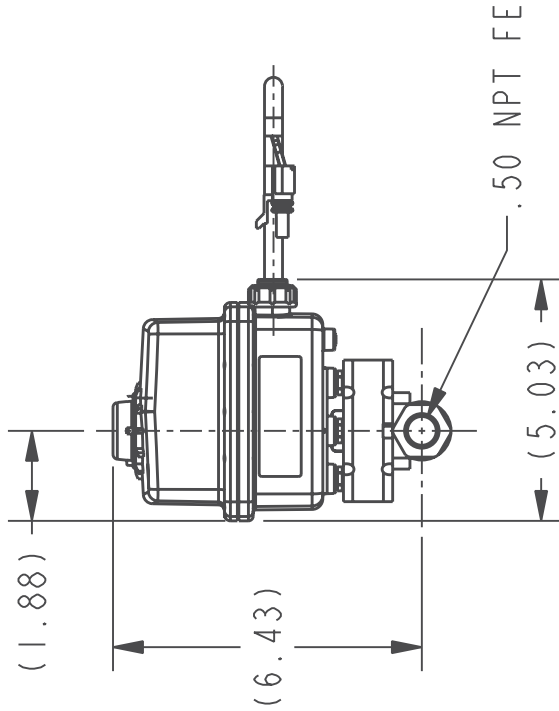
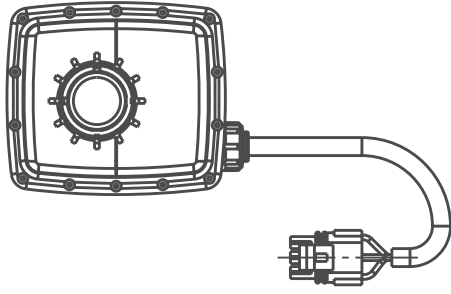
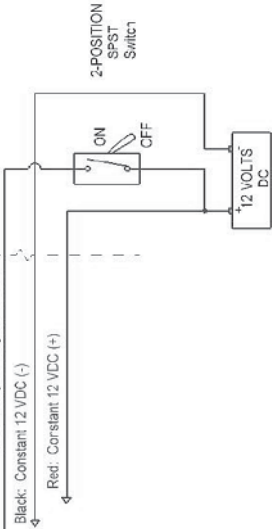

MODEL NAME 5209401 MDL CREATED 11/13/08 SHEET 1/2 A

REMOVE SHARP EDGES		THIRD ANGLE PROJECTION		OLD PART NO.	TOLERANCE
INCH [MILLIMETER]					EXCEPT AS NOTED
MATERIAL DESCRIPTION: KZCO 84D23-10D20-PO1		MATERIAL NO.	PATTERN NO.		.00 ±.03 .000 ±.010 ANGLES ±1°
THIS DESIGN IS THE PROPERTY OF W.S. DARLEY AND CO. - UNAUTHORIZED REPRODUCTION IS PROHIBITED		DO NOT SCALE PRINT			DR'N RJG CHKD DWS TRCD
W.S. Darley & Co. ITASCA, IL - CHIPPEWA FALLS, WI		DATE 13-Nov-08		VALVE - ACTUATED, 12VDC, .50NPT FE KZCO 84D23-10D20-PO1	
5209401		SCALE 1/4		5209401	

REVISED -24	REVISIONS 7/15/2008 9:41:57 AM	REVISIONS MADE by dswcm1	
----------------	-----------------------------------	-----------------------------	--

ACTUATOR LABEL
MASSCO LABEL DESCRIPTION
"ACTUATOR, EH3 12/24 VDC"

ACTUATOR LABEL
MASSCO LABEL DESCRIPTION
"ACTUATOR, EH3 12/24 VDC"

INPUT/OUTPUT POWER - 1224 VDC
1 - BLACK - POWER (-) NEGATIVE
2 - RED - POWER (+) POSITIVE
3 - WHITE - SIGNAL (+) POSITIVE TO OPEN
4 - -

DIP SW 4 ON

RED MOTOR LEAD TO RED DOT

PIN A - RED
PIN B - BLACK
PIN C - WHITE

PROGRAM NOTE

SCALE .500

PROGRAM NOTE

SCALE .500

STANDARD TOLERANCES
ALL DIMENSIONS IN INCHES UNLESS OTHERWISE SPECIFIED

FINISHES: 20-100 MICRA
DIMENSIONS: 100-20-100

MASSCO SET DATA
CONTROL INPUT = 1
FEEDBACK = 0
OPERATION = 0
MOTOR = M2
SPEED CT = 0.8
ZEROSSET = 135
RANGE TOLERANCE = 1
ROTATION = CCW
ACTUATOR RANGE = 0.00/0.00
DESIGN VOLTAGE = E
DIP SW = 3
LABEL = K2000
OPTIONS = 0
PLUS TYPE = P
TEST PLUG =

QTY	PART NUMBER	DESCRIPTION	MATERIAL
21	EH-502	LABEL, EH ACTUATOR, 2.8" X 1", THERMAL TRANSFER, WHITE	NO MATERIAL
20	800019	HARNESSES, BMA 357, WY9122.5"	POLYPROPYLENE TAIC 20
19	EH3-15-Y	FLAG, YELLOW	
18	309-0029	PCB ASSY, EH3 LT SOLID STATE 12 VDC	NO MATERIAL
17	100-001	GEAR MOTOR, M2 18 RPM/CM/LON	STAINLESS STEEL TYPE 303
16	03X-222	NUT, HEX HEAD, SEPARATED FLANGE, .250-20 UNC-2B	STAINLESS STEEL TYPE 303
15	EH3-136	STUD, 1/4-20 X 1/2 MTG	STAINLESS STEEL TYPE 303
14	EH-104	RETAINER, PUSH ON 5/16" SHAFT	NO MATERIAL
13	494-0109	CAM ASSY, EXTD LOBE FOR EH3S E-OMP	SILICONE RED, 75 DUROMETER
12	EH-502	LABEL, EH ACTUATOR, 2.8" X 1", THERMAL TRANSFER, WHITE	POLYCARBONATE
11	EH-130	O-RING, DOME	STAINLESS STEEL TYPE 303
10	EH3-114	DOME CLEAR	NYLON DPC BK/SHL BLACK
9	EHPT-1103	SCREW PAN PHILLIPS, HIGH-LOW, 5-20 X .502	STAINLESS STEEL TYPE 18-8
8	EH3-1001-N	LID, CASE, EH3, DOME	STAINLESS STEEL TYPE 18-8
7	EH3-100	SCREW, 8-32 X 1.25 PPHMS SS	STAINLESS STEEL TYPE 18-8
6	EH-157	SCREW, 8-18 X .987 150 PPH SS	STAINLESS STEEL TYPE 18-8
5	EH3-1030	O-RING, EH3, CASE LID, # 120	SILICONE RED, 75 DUROMETER
4	EH-130	O-RING, 80/106, PRESSURE TEST PORT	FLUOROCARBON (BLACK), 75 DUROMETER
3	EHPT-140	O-RING, #112, MOTOR SHAFT, VITON	FLUOROCARBON (BLACK), 75 DUROMETER
2	EH3-1003H	LOWER CASE - EH3 INTERNAL MTG	NYLON DPC BK/SHL BLACK
1	408-0012	CASE KIT, EH3 IM DOME NYLON MO MTR	MATERIAL

REVISIONS

LTR	DESCRIPTION	DATE	CHG NO.	APPR'D

60AD WIRING
Standard On/Off applications, SPST Switch
24 VDC

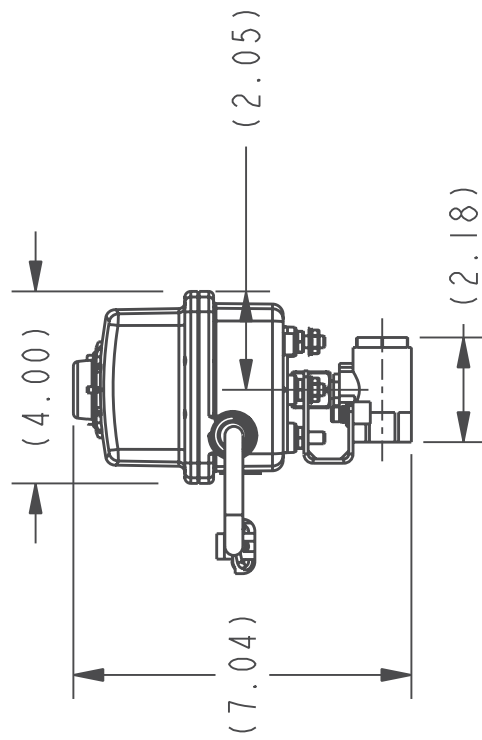
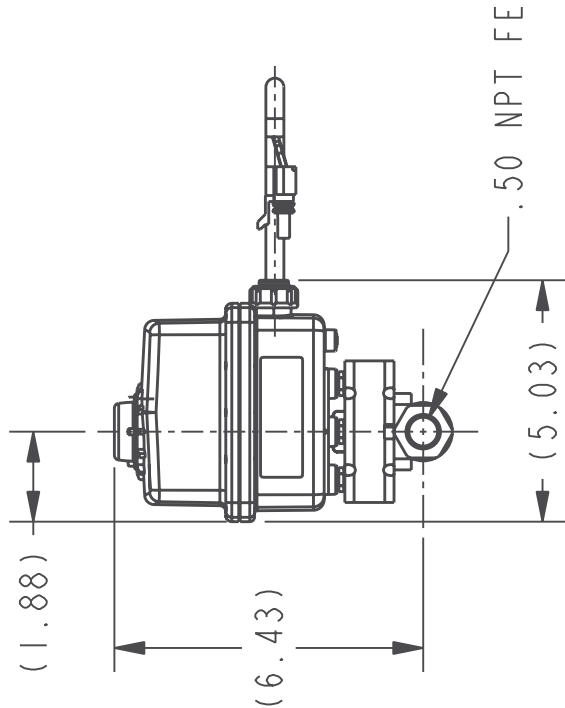
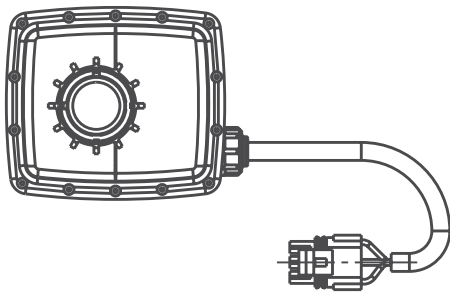
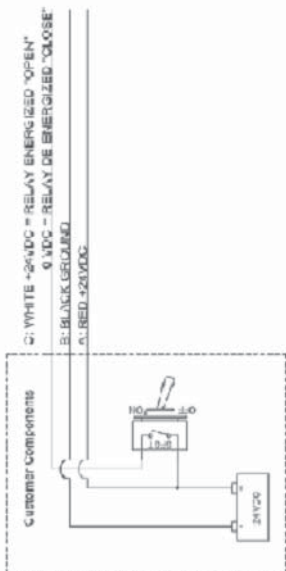

REMOVE SHARP EDGES

INCH
[MILLIMETER]



OLD PART NO.

PATTERN NO.

TOLERANCE
EXCEPT
AS NOTED

.00 ±.03
.000 ±.010
ANGLES ±1°

DR 'N

RJG

CHKD

DWS

TRCD

DATE 13-Nov-08

SCALE 1/4

MODEL NAME 5209402 MDL CREATED 11/13/08 SHEET 1/3 A

W.S. Darley & Co.
ITASCA, IL - CHIPPEWA FALLS, WI

VALVE - ACTUATED, 24VDC, .50NPT FE
KZCO 84D23-60AD-M

5209402

MATERIAL DESCRIPTION:
KZCO 84D23-60AD-M

THIS DESIGN IS THE PROPERTY OF
W.S. DARLEY AND CO. - UNAUTHORIZED
REPRODUCTION IS PROHIBITED

DO NOT SCALE PRINT

ALL DIMENSIONS IN
INCHES UNLESS NOTED

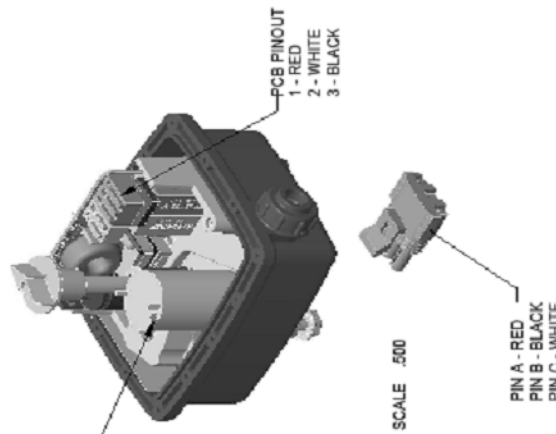

MAS80 SET DATA
 CONTROL INPUT = 1
 FEEDBACK = 0
 OPERATION = 0
 MOTOR = M
 SPEED CT = 0.8
 ZEROSET = 135
 RANGE TOLERANCE = 1
 ROTATION = CC081
 ACTUATOR RANGE = 0.0010.00
 DESIGN VOLTAGE = D
 DIP SX =
 LABEL = KZCO
 OPTIONS = 0
 PLUG TYPE =
 TEST PLUG =



2180 KZ PARKWAY
 GREENWOOD, NE 68308 USA
 TEL: 402.944.2020
 FAX: 402.944.2022

DATE: 2007-04-10
 DESIGNED: L. ERDKAMP
 DRAWN: W. FEDDE
 APPROVED: A. KOTTAS

SCALE: 500
 SIZE: B
 PART NO: 000-60AD-M
 DRAWING NO: 000-60AD-M

REVISION: 000-60AD-M
 SHEET: 1 OF 1

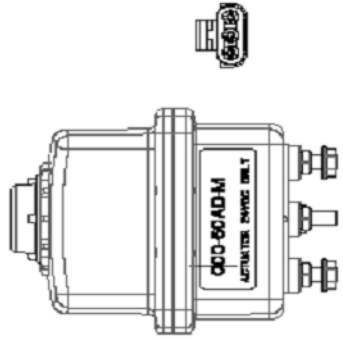
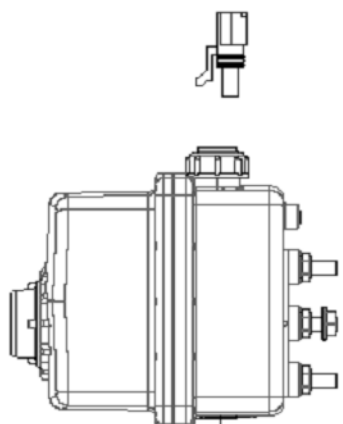

QTY	PART NUMBER	DESCRIPTION	MATERIAL
1	EH-502	LABEL, EH ACTUATOR, 2.5" X 1", THERMAL TRANSFER, WHITE	NO. MATERIAL
2	QX-222	NUT, HEX HEAD, SERRATED FLANGE, .256-28 UNC-2B	STAINLESS STEEL, TYPE 303
4	EH3-135	STUD, 1/4-20 X 1/2 MTG	STAINLESS STEEL, TYPE 303
5	800018	HARNES, 60A, 3ST, WPST, 22.5"	
4	EH3-115-Y	FLAG, YELLOW	POLYPROPYLENE, TALC_20
3	800468	PCB ASSY, EH3 24VDC 60AD/60DF	
2	EH3-110	GEAR MOTOR, EH3 SERIES M1 18 RPM @ 12VDC	
1	488-0005	CASE KIT, EH3 IM DOME NYLON M1 & N1 MTR	

STANDARD TOLERANCES - ALL DIMENSIONS IN UNLESS SHOWN:
 TOTAL FINISH: .005 INM
 SURFACE FINISH: 12.5 IN
 X.X: .1
 X.XX: .01
 X.XXX: .005
 X.XX": .001"

WEIGHT: .21 LB/MCU IN
 MASS: .502 LBM
 SURF AREA: 163.303 SQ IN
 VOLUME: 1.533 CU IN

REVISION	REVISION DATE	REVISION BY
-6+	8/12/2008 9:18:50 AM	bgotschal

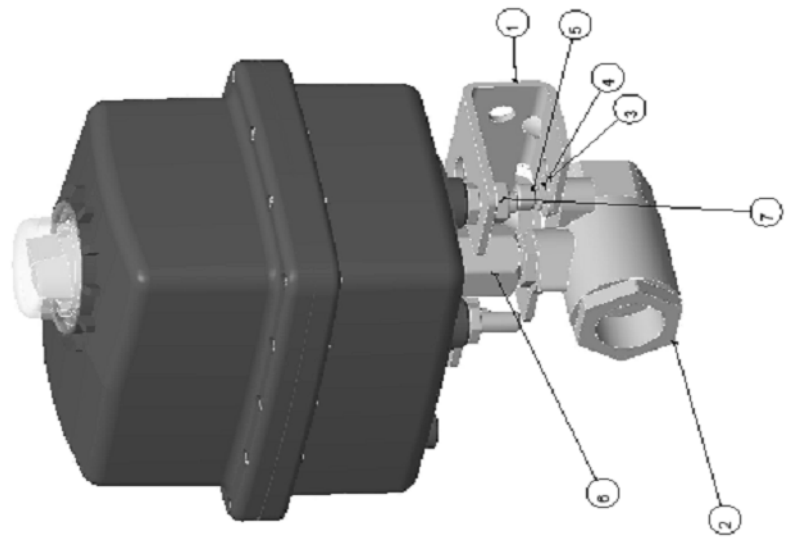
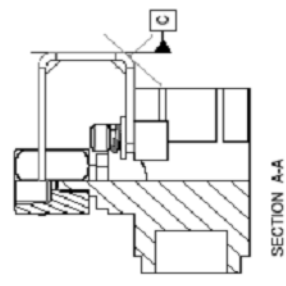
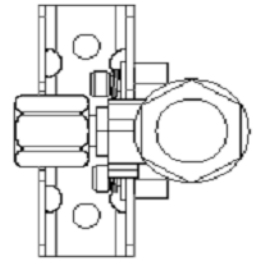
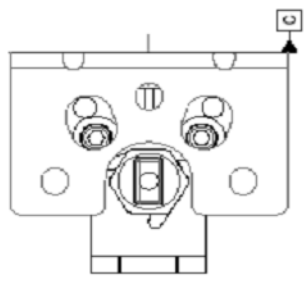

ACTUATOR SHOWN IS REPRESENTATIVE USED
ONLY TO SHOW PROPER ORIENTATION TO VALVE.

QTY	PART NUMBER	DESCRIPTION	MATERIAL
7	QK-222	NUT, HEX HEAD, SERRATED FLANGE, .250-20 UNC-2B	STAINLESS STEEL TYPE 303
6	EH-146	COUPLER, 1/4" ~ 1/2" APOLLO	STAINLESS STEEL TYPE 316
5	EH-158	SCREW, #10-24 X 3/8" SS SOCKET HEAD	STAINLESS STEEL TYPE 303 OR 316
4	EHPT-105	WASHER, LOCK, .197 ID X .334 OD X .047 T	STAINLESS STEEL TYPE 316
3	EHPT-110	WASHER, FLAT, #10 18-8 SS	STAINLESS STEEL TYPE 316
2	EH3-54D	VALVE, 1/2" 2-WAY APOLLO 70-03-01 BRONZE BALL VALVE	BRONZE
1	EH3-174	BRACKET, MOUNTING EH3 SERIES	STAINLESS STEEL TYPE 304
DET	QTY	PART NUMBER	DESCRIPTION

DATE: 2007-08-08	DESIGNED: L. LERDKAMP	APPROVED: L. LERDKAMP
DESIGNED: L. LERDKAMP	DRAWN: C. HOWARD	SCALE: .750
APPROVED: L. LERDKAMP	SCALE: B	MATERIAL: AS NOTED
PART NO: 84D23	REVISION: -6+	DRAWING NO: 84D23

STANDARD TOLERANCES: -ALL DIMENSIONS IN INCHES UNLESS NOTED TOTAL FINISH: .005 IN CORNER BREAK: .015 IN SURFACE FINISH: 125 IN SURFACE: .005 IN SURFACE: 125 IN SURFACE: 125 IN	KZCO Inc. 2080 ICE PARKWAY GREENWOOD, NE 68308 USA PHONE: 414.624.1217 FAX: 414.624.1212
TITLE: VALVE KIT, EH3 OFFSET MTG 1/2" 2-PC BRZ REF:	PART NO: 84D23 REVISION: -6+ DRAWING NO: 84D23

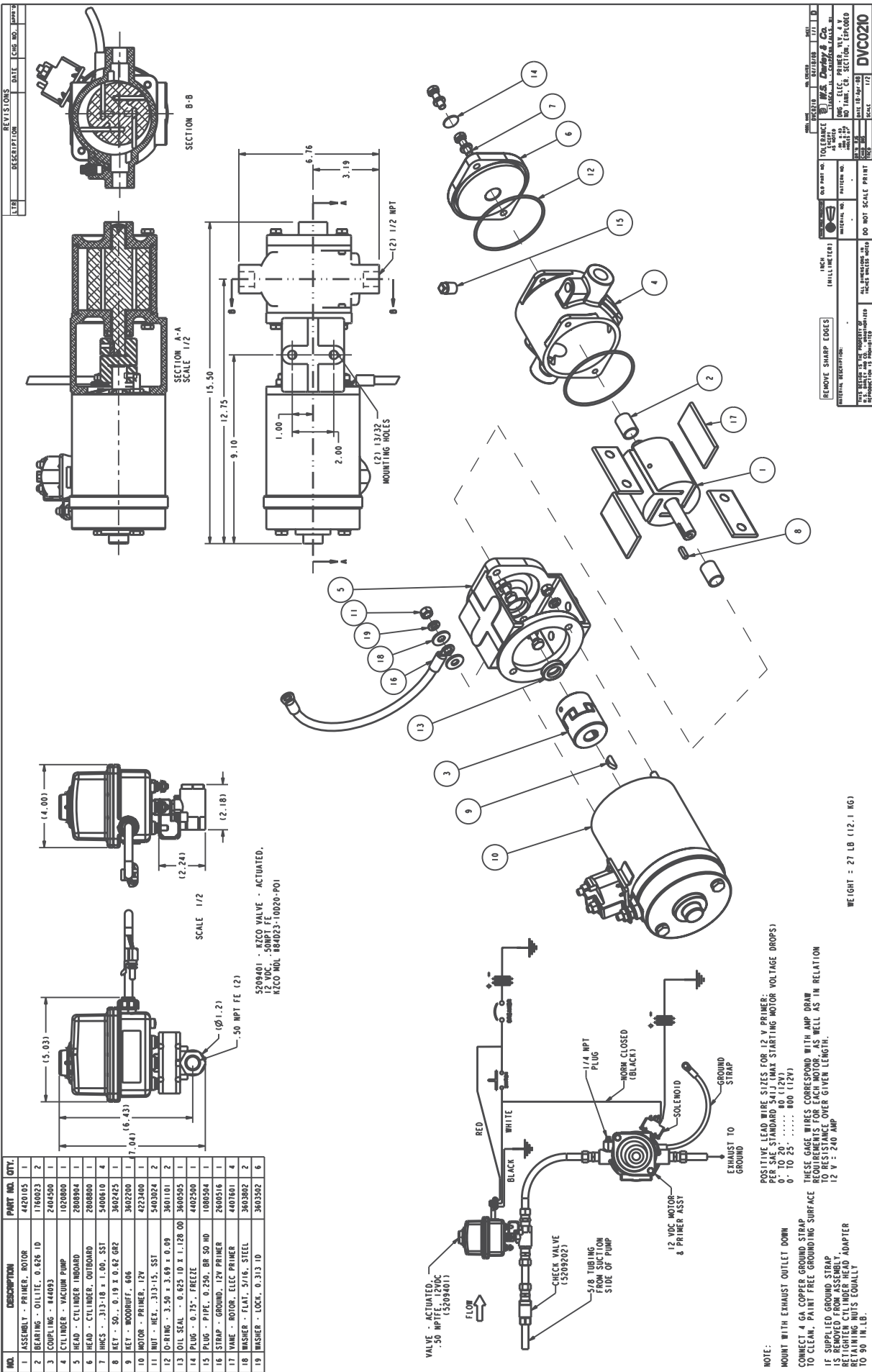

NO.	DESCRIPTION	PART NO.	QTY.
1	ASSEMBLY - PRIMER, ROTOR	4420105	1
2	BEARING - OILITE, 0.626 ID	1760023	2
3	COUPLING - #44093	2404500	1
4	CYLINDER - VACUUM PUMP	1020600	1
5	HEAD - CYLINDER INBOARD	2808904	1
6	HEAD - CYLINDER OUTBOARD	2808800	1
7	WKS - 3/13-18 x 1.00, SST	5400510	4
8	WKS - 3/13-18 x 0.82 GR2	3602325	1
9	WKS - 3/13-18 x 0.82 GR2	3602200	1
10	MOTOR - PRIMER, 12V	4223400	1
11	WHT - HEX., 3/13-15, SST	5403824	2
12	O-RING - 3.50 x 3.69 x 0.09	3601101	2
13	OIL SEAL - 0.625 ID x 1.128 OD	3600505	1
14	PLUG - 0.75" FREEZE	4402500	1
15	PLUG - PIPE, 0.750, BR SO HD	1080504	1
16	STRAP - GROUND, 12V PRIMER	2600516	1
17	WASHER - ROTOR, ELEC PRIMER	4407601	4
18	WASHER - FLAT, 3/16, STEEL	3603802	2
19	WASHER - LOCK, 0.313 ID	3603302	6

5209401 - RZCO VALVE - ACTUATED.
12 VDC, .50NPT FE
RZCO MOL 86023-10020-POI

NOTE:
POSITIVE LEAD WIRE SIZES FOR 12 V PRIMER:
PER SAE STANDARD S-411 MAX STARTING MOTOR VOLTAGE DROPS:
0 - TO 25 800 (12V)
0 - TO 25 800 (12V)

THESE GAUGE WIRES CORRESPOND WITH AMP DRAW
TO CLEAN, PAINT FREE GROUNDING SURFACE
TO RESISTANCE OVER GIVEN LENGTH.
12 V : 240 AMP

CONNECT 4 GA COPPER GROUND STRAP
TO CLEAN, PAINT FREE GROUNDING SURFACE
IF SUPPLIED GROUND STRAP
IS REMOVED FROM ASSEMBLY.
RETIGHTEN CYLINDER HEAD ADAPTER
RETAINING NUTS EQUALLY
TO 90 IN.LB.

WEIGHT - 27 LB (12.1 KG)

REV.	DESCRIPTION	DATE	CHK NO.	APP'D

REV	DESCRIPTION	DATE	CHK NO.	APP'D

REV	DESCRIPTION	DATE	CHK NO.	APP'D

REV	DESCRIPTION	DATE	CHK NO.	APP'D

REV	DESCRIPTION	DATE	CHK NO.	APP'D

REV	DESCRIPTION	DATE	CHK NO.	APP'D

REV	DESCRIPTION	DATE	CHK NO.	APP'D

REMOVE SHARP EDGES
ALL DIMENSIONS IN
INCH UNLESS OTHERWISE
SPECIFIED
DO NOT SCALE PRINT

DVC0210

NO.	DESCRIPTION	PART NO.	QTY.
1	ASSEMBLY - PRIMER, ROTOR	4420105	1
2	BEARING - OILITE, 0.626 ID	1760023	2
3	COUPLING - #44093	2404500	1
4	CYLINDER - VACUUM PUMP	1020000	1
5	HEAD - CYLINDER, INBOARD	2808904	1
6	HEAD - CYLINDER, OUTBOARD	2808900	1
7	WASHER - 3/16 X 1.00, SST	5400510	4
8	WASHER - 5/16 X 0.82 GR2	3602425	1
9	WASHER - WOODRUFF, 606	3602500	1
10	WASHER - PRIMER, 24V	4423500	1
11	WASHER - HEX., 3/16 X 1.00, SST	5403024	2
12	O-RING - 3.50 X 3.69 X 0.09	3601101	2
13	OIL SEAL - 0.625 ID X 1.128 OD	3600505	1
14	PLUG - 0.75" - FREEZE	4402500	1
15	PLUG - PIPE, 0.250, BR 50 HD	1080504	1
16	STRAP - GROUND, 12V PRIMER	2600516	1
17	WASHER - ROTOR, ELEC PRIMER	4407601	4
18	WASHER - FLAT, 5/16, STEEL	3603802	2
19	WASHER - LOCK, 0.313 ID	3603502	6

REV.	DESCRIPTION	DATE	DESIGN NO.	APP'D.

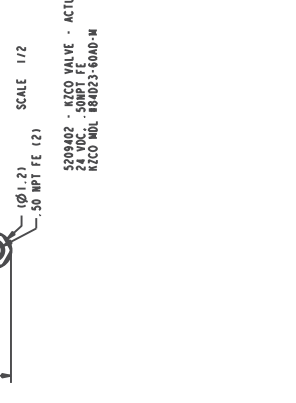
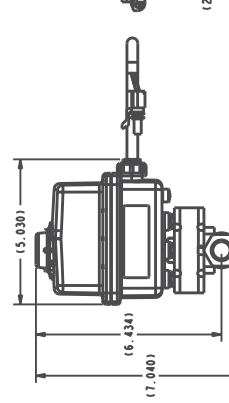
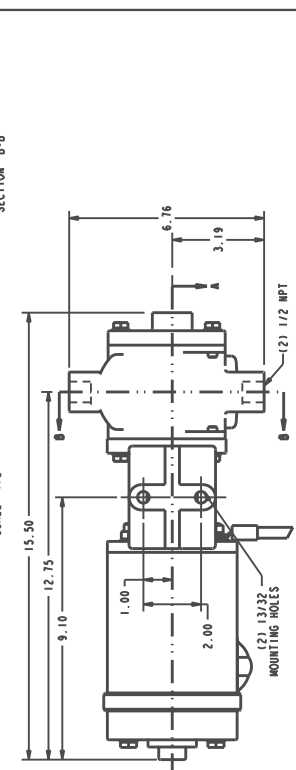
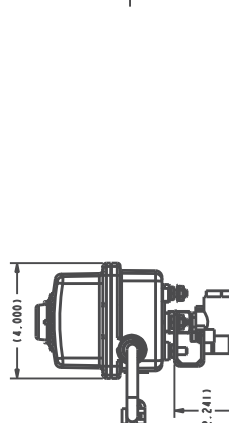
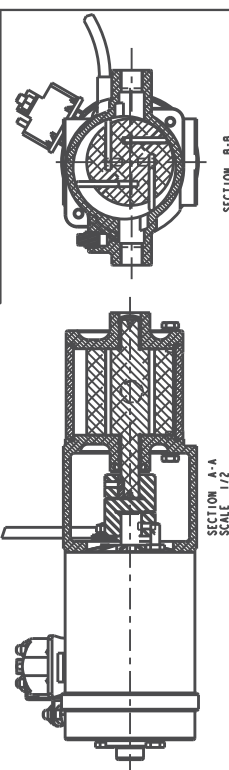

5209402 - RZCO VALVE - ACTUATED,
24 VDC, .50NPT FE
RZCO MDL 864023-60AD-M

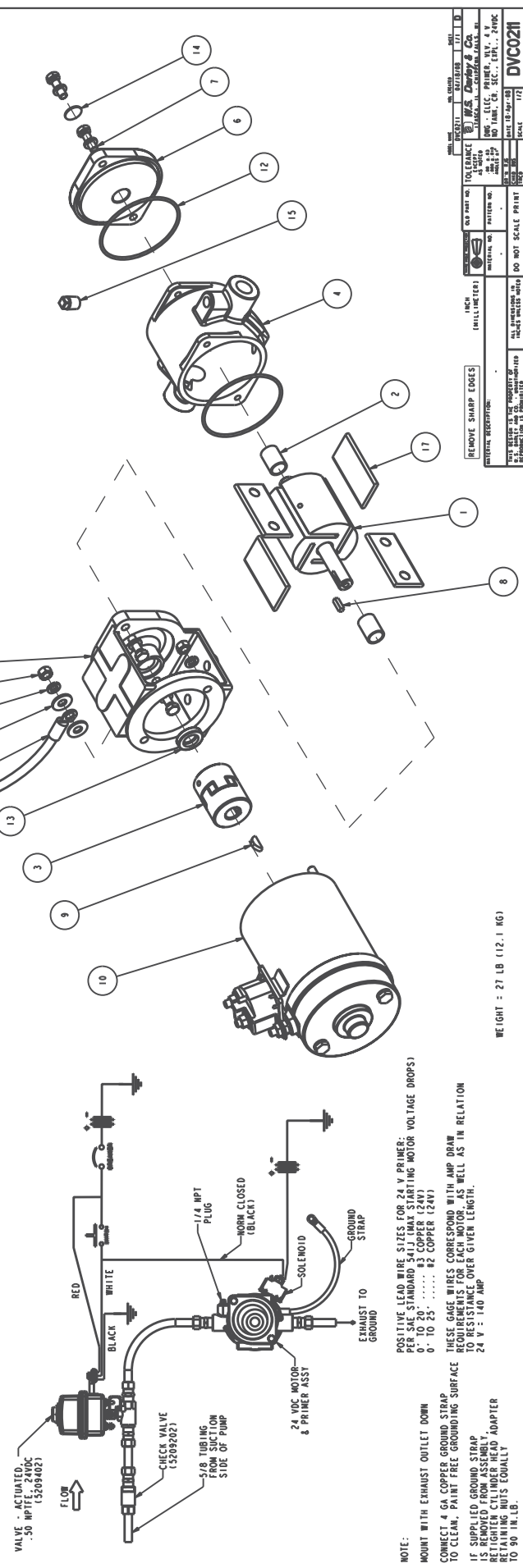

NOTE:
MOUNT WITH EXHAUST OUTLET DOWN
CONNECT 4 GA COPPER GROUND STRAP TO CLEAN, PAINT FREE GROUNDING SURFACE
IF SUPPLIED GROUND STRAP IS REMOVED FROM ASSEMBLY, RETIGHTEN CYLINDER HEAD ADAPTER REMAINING NUTS EQUALLY TO 90 IN.LB.
POSITIVE LEAD WIRE SIZES FOR 24 V PRIMER:
PER SAE STANDARD S410 MAX STARTING MOTOR VOLTAGE DROPS)
0 - TO 25 #2 COPPER (24V)
THESE GAUGE WIRES CORRESPOND WITH AMP DRAW TO RESISTANCE OVER GIVEN LENGTH.
24 V = 140 AMP

WEIGHT - 27 LB (12.1 KG)

REV.	DESCRIPTION	DATE	DESIGN NO.	APP'D.

REV.	DESCRIPTION	DATE	DESIGN NO.	APP'D.

REV.	DESCRIPTION	DATE	DESIGN NO.	APP'D.

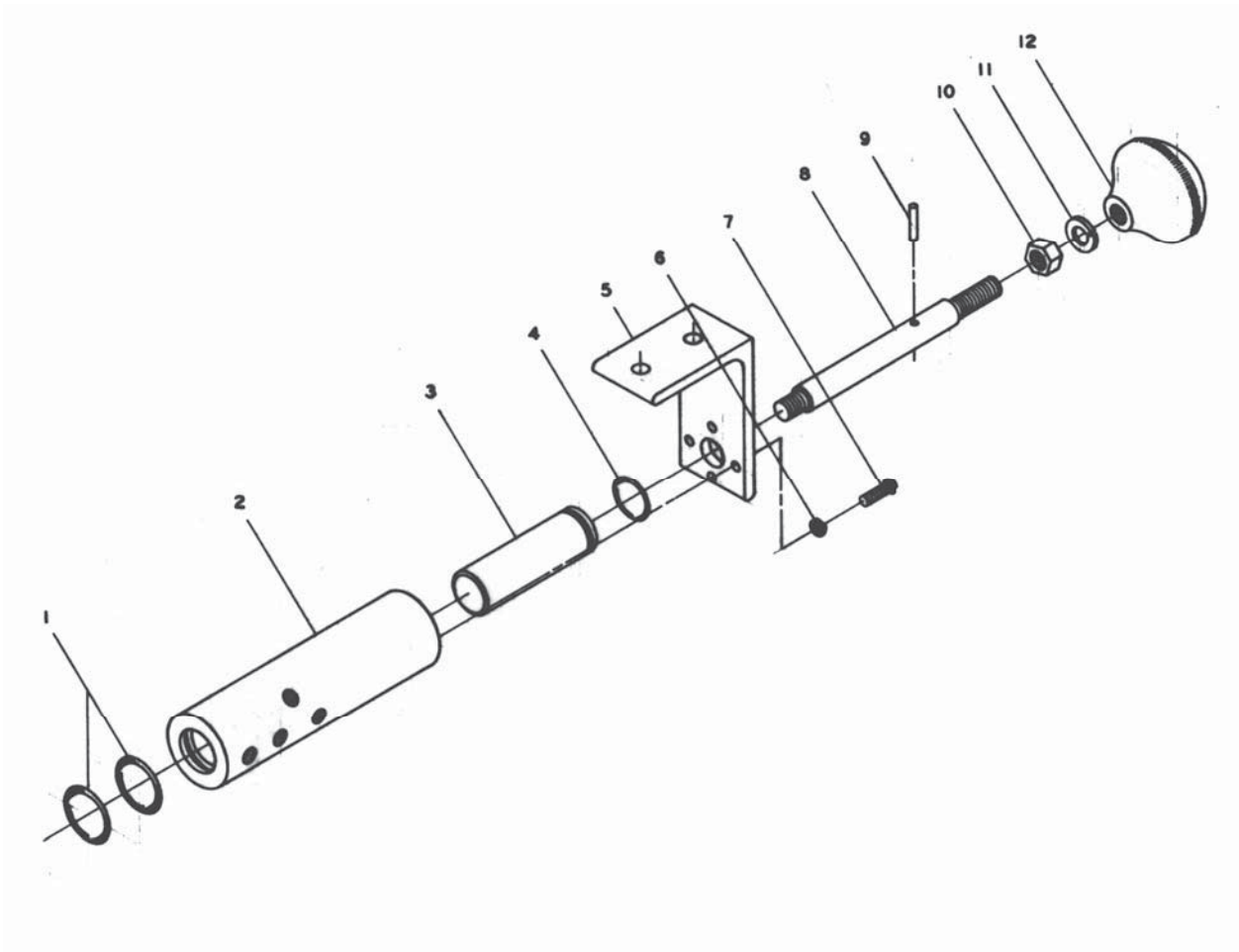

PARTS LIST FOR MULTIPLE DRAIN VALVE

DRAWING NO. DGC0112

Rep. No.	Name of Part	Qty	Rep. No.	Name of Part	Qty
1	O-ring – Body	2	7	Round Head Cap Screw	4
2	Drain Valve Body	1	8	Drain Valve Stem	1
3	Drain Valve Plug	1	9	Pin	1
4	O-ring – Plug	1	10	Hex Nut	1
5	Drain Valve Mounting Bracket	1	11	Lock Washer	1
6	Lock Washer	4	12	Knob	1

NO.	DESCRIPTION	PART NO.	QTY.
1	BEARING - O-LITE, 0.500 ID	1760024	1
2	BODY - MULTI DRAIN VALVE	5329401	1
3	BRACKET - MULTI DRAIN VALVE	4031300	1
4	CAP - MULTI DRAIN VALVE	5323802	1
5	DECAL - DRAIN VALVE	1963200	1
6	GREASE ZERK - .25-28	4403200	1
7	HANDWHEEL	3001800	1
8	HHCS - .250-20 x 0.88, 18-8	5400658	2
9	O-RING - 0.38 x 0.50 x 0.06	3601000	1
10	O-RING - 1.62 x 2.00 x 0.19	3601305	1
11	RHMS - NO.10-24 x 0.50, SST	5402046	3
12	RING - RETAINER, 68011	3600435	1
13	SEAL - MULTI DRAIN VALVE	3802602	1
14	SSS - 1/4-20 x 0.38, SST	5402603	1
15	STEM - MULTIPLE DRAIN VALVE	5241302	1
16	WASHER - .52 X 1.12 X .12	3603319	1
17	NUT - JAM, .500-20, 18-8 SST	5403219	1
18	NUT - HEX, .250-20, 18-8 SST	5403027	2

REVISIONS			
LTR	DESCRIPTION	DATE	CHG. NO.
A	ADDED ASSEMBLY NOTE	29SEP2005	2005-281
B	WAS 4031300	03APR2006	2006-110
C	WAS RETAINER RING 3600435	28NOV2007	2007-456
D	WAS 5400003	30JAN2008	2008-042
E	ADDED 5403027	15FEB2008	2008-061

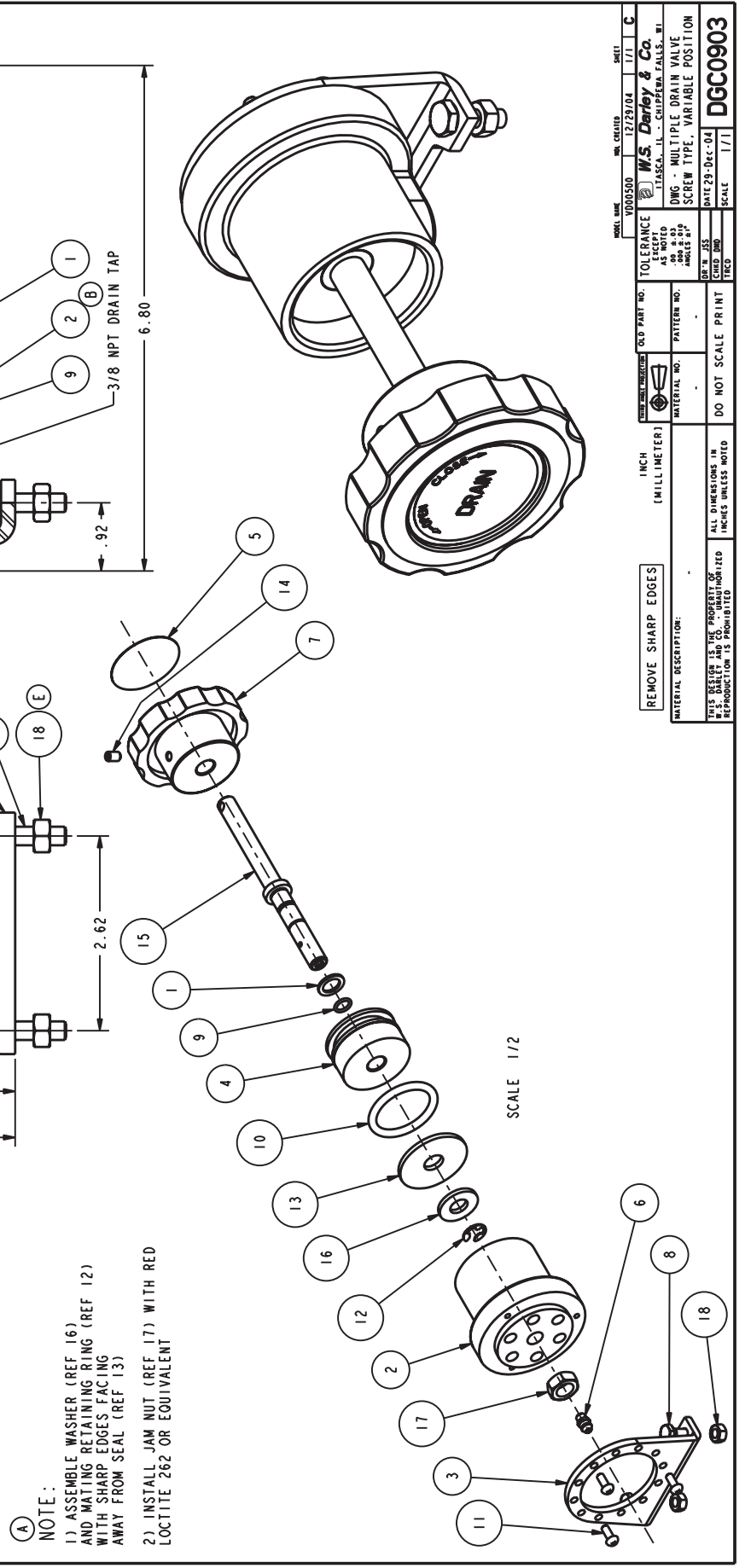

NOTE:
 1) ASSEMBLE WASHER (REF 16) AND MATING RETAINING RING (REF 12) WITH SHARP EDGES FACING AWAY FROM SEAL (REF 13)
 2) INSTALL JAM NUT (REF 17) WITH RED LOCTITE 262 OR EQUIVALENT

MODEL NAME	V000300	REV. CREATED	12/29/04	SHEET	1/1
OLD PART NO.		PATTERN NO.		DATE	1/1
MATERIAL NO.		DR. JES	DATE 29-Dec-04	CHG. JMD	
SCALE	SCALE	SCALE	SCALE	SCALE	SCALE
DO NOT SCALE PRINT					

W.S. Darley & Co.
 1555 S. W. GILBERT AVE., WALKER, MI 49787
 TOLERENCE AS NOTED EXCEPT: .0008 ± 0.015 ANGLES ± 0.1°

REMOVE SHARP EDGES

SCALE 1/2

DO NOT SCALE PRINT

ALL DIMENSIONS IN INCHES UNLESS NOTED

THIS DESIGN IS THE PROPERTY OF W.S. DARLEY AND CO. UNAUTHORIZED REPRODUCTION IS PROHIBITED

DGC0903

BALL VALVE QUARTER TURN - SELF LOCKING

The Darley Ball Valve is a quarter turn, all bronze valve designed for the fire service.

The ball is cast bronze, precision machined *stainless steel ball* for long trouble free service. It is easily serviced in the field.

The lever is self locking and easily adjusted, even under extreme high pressure.

TO DISASSEMBLE AND REPAIR THE BALL VALVE ILLUSTRATION DGC0100

TOOLS REQUIRED:

- 3/16" Allen Wrench
 - 1-1/8" Wrench
 - 3/4" & 1" Wrench
 - Vise Grips or Pliers
1. Remove cap nut (20) and adjusting nut (16).
 2. Lever Assembly (11) pulls straight up. Watch for 2 cam balls (12).
 3. Unbolt and remove clutch ring (9), clutch sleeve (8), valve stem (7), spring (14), and valve stem washer (15). Check clutch ring (9) and sleeve (8) for scoring or excessive wear. Check o-ring (26). Replace if necessary.
 4. Remove nipple (2). Check Quad Ring (25). Replace if necessary.
 5. Unscrew ball guide screw (6). Check o-ring (23). Replace if necessary.
 6. Remove valve ball (3). Check for scratches, corrosion, and wear. Replace if necessary.
 7. Remove seat assembly (4). Check condition of rubber seat. Replace seat assembly if necessary.

REASSEMBLY OF BALL VALVE ILLUSTRATION DGC0100

1. Position ball (3) in body so ball guide screw (6) engages bottom of ball as it is screwed into position.
2. Put valve stem (7) into position. Make certain stem engages slot on top of ball.
3. Slip washer (15), spring (14), and clutch sleeve (8) over the stem. Place clutch ring (9) over the sleeve and secure with the four (4) 1/4" NC x 5/8" socket head cap screws.
4. Set the two cam balls (12) into the V grooves in the clutch sleeve (8) and drop lever assembly over them. Tighten the adjusting nut (16) so that approximately 1/8" play is left at the end of a 6" lever. Over tightening this nut will make the clutch lock inoperative. Lock adjusting nut (16) with cap nut (20). Recheck this adjustment after valve is placed in service.
5. Place seat assembly (4), seat o-ring (5), and quad ring (25) into position.
6. Secure nipple (2) to valve body with eight (8) 1/4" NC x 5/8" socket head cap screws.

**If more information is needed, call W.S. DARLEY & CO. at
Chippewa Falls, WI at 800-634-7812 or 715-726-2650**

LETTER	CHANGE NO.	DATE
(A)	96-53	5/15/96

REP. NO.	NAME OF PART	QTY.
1	DISCHARGE VALVE BODY	1
2	VALVE NIPPLE	1
3	VALVE BALL	1
4	VALVE SEAT	1
5	O-RING	1
6	BALL GUIDE SCREW	1
7	VALVE STEM	1
8	CLUTCH SLEEVE	1
9	CLUTCH RING	1
10	LEVER CAM	1
11	FRONT MOUNT LEVER	1
12	CAM BALL	2
13	VALVE PIN	2
14	VALVE SPRING	1
15	VALVE STEM WASHER	1
16	ADJUSTING NUT	1
17	SPRING PIN-STL (A)	1
19	CONTROL LEVER BALL	1
20	CAP NUT	1
23	O-RING	1
25	QUAD RING	1
26	O-RING	1
27	O-RING	1
28	SOCKET HEAD CAP SCREW	4
29	SOCKET HEAD CAP SCREW	8

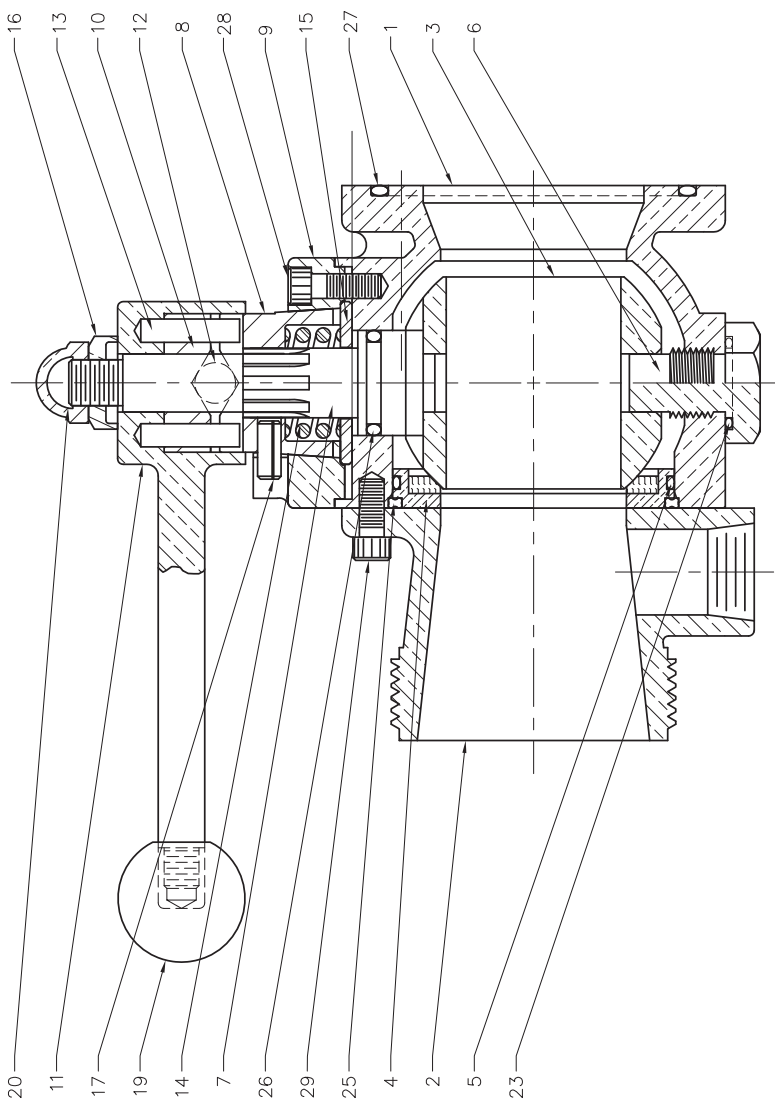

INCH
[MILLIMETER]

THIRD ANGLE PROJECTION

W.S. DARLEY & Co.
WELLSVILLE PARK, IL - GRIFFINVA FALLS, WI

DWG - BALL VALVE ASSEMBLY
CROSS SECTION

DATE NOV12/65
SCALE 1/1

DGC0100

TOLERANCE
EXCEPT
AS NOTED
0.00 ± 0.02
ANGLES 91°

CHKD. JCM
TROLL/HH 5/96

OLD PART NO.
C1200

DO NOT SCALE PRINT

ALL DIMENSIONS IN INCHES UNLESS NOTED

THIS DESIGN IS THE PROPERTY OF W.S. DARLEY & CO. UNLESS AUTHORIZED REPRODUCTION IS PROHIBITED

REMOTE CONTROL SUCTION RELIEF VALVE DRAWING DGC0115

The suction relief valve bypasses water from the pump suction extension to the ground at a set pressure, preventing excessive rise of supply pressure when relay hose lines are shut off.

Turning pressure setting hand wheel (14) clockwise raises the relief pressure, and counterclockwise lowers it.

The self cleaning fine mesh strainer will prevent entry of solids that could cause the relief valve to malfunction. Open the strainer flush valve to remove small accumulations. This is accomplished by turning the strainer flush valve knob (6) counterclockwise 2 to 3 full turns. Strainer trapped debris will be flushed to the ground. Pump supply pressure should be 50-100 PSI when performing this procedure.

TO SET SUCTION RELIEF VALVE

1. Connect a discharge line from an auxiliary pump to the pump suction containing the suction relief valve. The auxiliary pump must be able to supply a pressure greater than the desired pressure setting of the suction relief valve.
2. Close all other discharge and suction valves.
3. Increase auxiliary pump engine throttle setting until pressure gage indicates the pressure that suction relief valve is open.
4. If suction relief valve opens to bypass excessive pressure, slowly turn hand wheel (14) clockwise until valve closes.
5. If suction relief valve does not open, turn hand wheel (14) counterclockwise until valve opens and begins bypassing water. Continue to turn hand wheel (14) counterclockwise 2 more complete turns. Now slowly turn hand wheel clockwise until valve closes and stops bypassing water.

The suction relief valve will now prevent damage to the pump from a pressure surge (water hammer) which is the result of rapid closing or opening of relay line valves.

Should a higher or lower relief pressure be desired, repeat the above procedure.

CAUTION: With all discharge valves closed, the water in auxiliary pump casing will heat up rapidly. Avoid damage by allowing a very low flow of water to discharge when pump is running.

REMOTE CONTROL SUCTION RELIEF VALVE WITH MECHANICAL SHUTOFF DRAWING DGC0115

MAINTENANCE

Open the relief valve strainer flush valve (6) during every operation at 50-100 PSI supply pressure to insure against foreign material blocking the screen.

The relief valve, pilot unit, and strainer assemblies should be taken apart for inspection and cleaning at least annually, or as often as found necessary to insure trouble free performance.

To disassemble pilot head, first turn hand wheel (14) counterclockwise to remove spring compression. Remove the four 1/4" screws holding regulator spring housing (18). Lift out diaphragm (23) and pilot valve (51) assembly. Clean and make certain 3/32" diameter orifice hole is free of obstruction.

When reassembling pilot head, turn hand wheel (14) a few times clockwise to compress spring before tightening four screws holding spring housing. This will properly center valve seat and diaphragm.

The valve piston (40) and spring (44) chamber should be inspected and cleaned.

Replace diaphragm and o-rings if damaged or deteriorated.

Apply a thin coating of waterproof grease lubricant: to spring housing counterbore that guides pilot valve (51) and ball (52), to end of tension screw (17), and between piston (40) and center post

Self cleaning strainer (63) can be removed for inspection or replacement by alternately turning valve knob (6) and stop nut (7) counterclockwise until stem is free for removal. To avoid discharging water through opening created by stem (62) removal, pump should be completely shut down before stem (62) is removed. Inspect and clean screen (63) if required. Check quad ring (64) for damage or deterioration. Reverse procedure to reassemble valve. Use care when initially inserting screen into body to avoid damaging quad ring (64) or valve seat.

To replace flush valve seat (69), remove stem/screen assembly. Disconnect tubing lines attached to (61) body half, unscrew (61) body half from (70) body half. Replace (69) valve seat. Reverse procedure to reassemble valve.

SUCTION RELIEF VALVE PARTS LIST DRAWING DGC0115

REP NO.	DESCRIPTION	REP NO.	DESCRIPTION
3	Decal - RV Flush	41	Relief Valve Body
4	Panel Nut	42	O-ring Flange
5	Socket Set Screw	43	Spring Centering Plug
6	Flush Valve Knob	44	Spring
7	Stop Nut	45	O-ring Body Flange
11	Panel Valve Nut	46	O-ring Piston
12	Decal - Pressure Hi-Lo	50	O-ring, Bleed Port
13	Trim Plate	51	Pilot Valve
14	Hand wheel	52	Ball
16	Socket Set Screw	53	Pilot Valve Body
17	Spring Tension Screw	61	Body Half, Flush Valve
18	Spring Housing	62	Stem
19	Spring Retainer	63	Screen
20	Regulator Spring	64	Quad Ring
21	Pilot Valve Nut	66	O-ring Valve Seat
22	Housing Pilot Ring	67	Valve Seat Ring
23	Diaphragm	68	O-ring Flush Valve Body
37	O-ring, Relief Valve Head	69	Flush Valve Seat
38	Relief Valve Head	70	Body Half, Flush Valve
40	Relief Valve Piston	84	Flange
		86	Lock Washer Internal

**IF FURTHER INFORMATION IS NEEDED, CALL W.S. DARLEY & CO. AT
CHIPPEWA FALLS, WI. AT 800-634-7812 or 715-726-2650**

REVISIONS			
LTR	DESCRIPTION	DATE	CHG NO. / APPRD
A	ADDED LOCITTING NOTE	4NOV2002	2002-175 / TED

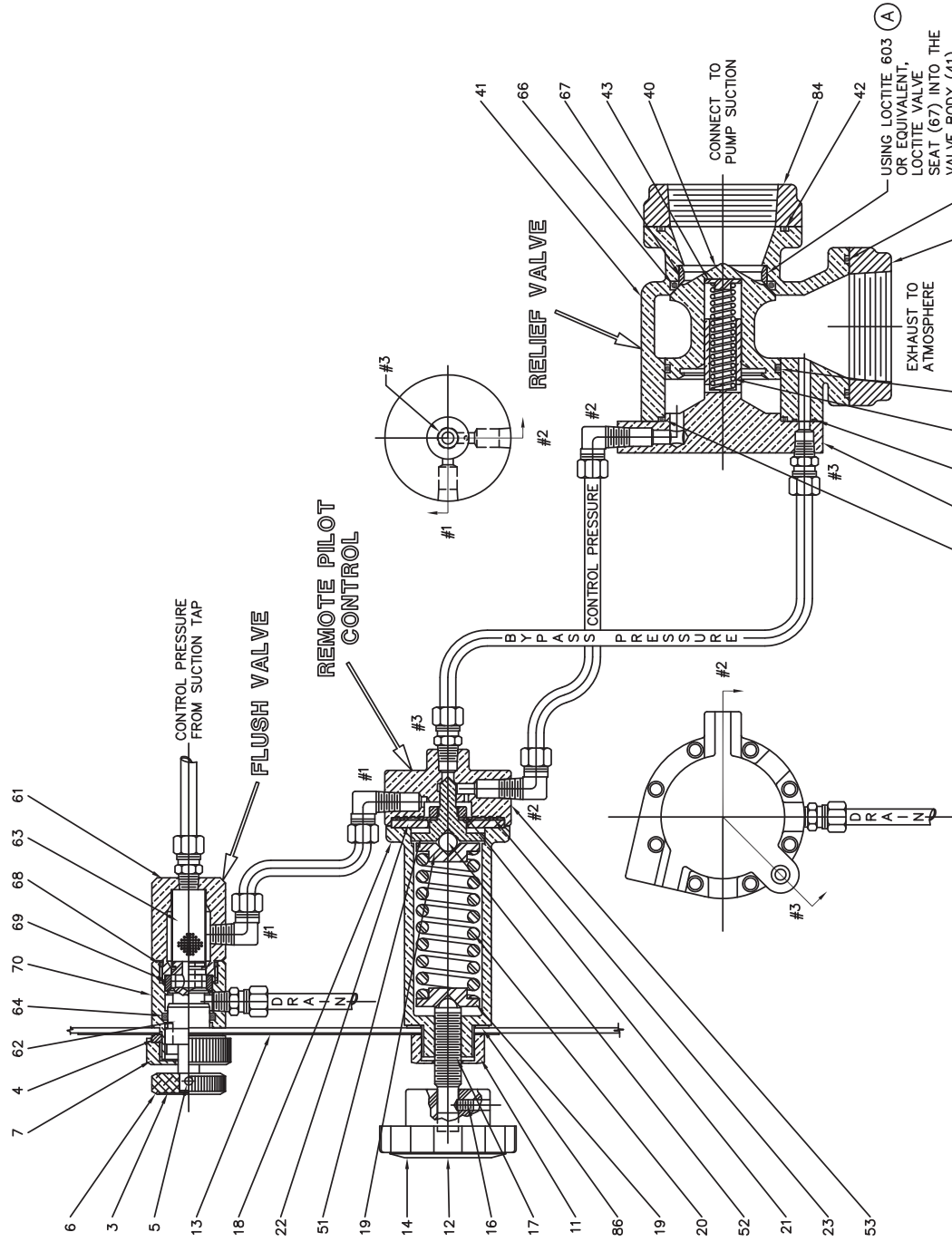

NOTE: REFERENCE TO DRAINS:
 IF THE REMOTE PILOT CONTROL IS MOUNTED BELOW THE RELIEF VALVE, IT WILL BE NECESSARY TO PLACE A TEE IN THE CONTROL PRESSURE LINE AND BYPASS PRESSURE LINE, AT THE LOWEST POINT, TO PROVIDE DRAINING. SUCH A DRAIN, IF INSTALLED, SHOULD NOT BE CONNECTED TOGETHER WITH THE RELIEF VALVE DRAIN. CONNECT DRAIN LINES TO SEPARATE INLET TAPS OF MULTIPLE DRAIN VALVE. DRAINS MUST BE CLOSED DURING OPERATION.

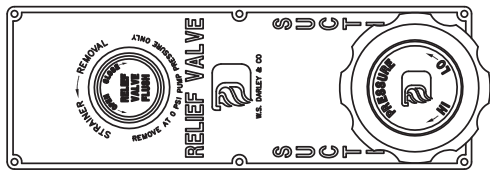

TOLERANCE EXCEPT AS NOTED FRACTIONS TO 0.01 ANGLES 30°		W.S. DARLEY & CO. MELROSE PARK, IL - CHIPPewa FALLS, WI	
OLD PART NO. G2453	PATTERN NO.	DWG - SUCTION RELIEF VALVE	DATE DEC17,91
MATERIAL NO.	DO NOT SCALE PRINT	SCALE 1/2	DGC0115
MATERIAL DESCRIPTION:		DRN S. LEE	CHKD TRCD
THIS DESIGN IS THE PROPERTY OF W.S. DARLEY & CO. UNAUTHORIZED REPRODUCTION IS PROHIBITED.		DO NOT SCALE PRINT	

W.S. DARLEY & CO.

REMOTE CONTROL PRESSURE RELIEF VALVE WITH MECHANICAL SHUTOFF

Refer to Drawing DGC0141

The relief valve bypasses water from the pump discharge manifold to the suction chamber at a set pump pressure, preventing excessive rise of discharge pressure when hose lines are shut off.

Turning pressure setting hand wheel (14) clockwise raises the relief pressure, and counter clockwise lowers it.

The self-cleaning fine mesh strainer will prevent the entry of solids that could cause the relief valve to malfunction. Open the strainer flush valve to remove small accumulations. This is accomplished by turning the strainer flush valve knob (6) counter clockwise 2 to 3 full turns. Strainer trapped debris will be flushed to the ground. Pump supply pressure should be 50-100 PSI when performing this procedure.

TO SET RELIEF VALVE

1. Turn four-way valve OFF.
2. Open at least one discharge valve and increase engine throttle setting until pressure gage indicates the pressure at which relief valve is to open.
3. Turn four-way valve ON.
4. If gage reading drops below pressure set in step 2, turn hand wheel (14) clockwise until pressure returns to set point.
5. If gage reading does not drop, turn hand wheel (14) counter clockwise until pressure drops 5 to 10 PSI below set point. Then slowly turn hand wheel clockwise until pressure returns to pressure set in step 2.

The relief valve will now prevent the discharge pressure from rising above that for which it is set, and requires no further attention.

Should a higher or lower relief pressure be desired, repeat above procedure.

CAUTION

With all discharge valves closed, water in the auxiliary pump casing will heat up rapidly. To avoid possible damage, allow a very small stream of water to discharge when the pump is running.

REMOTE CONTROL PRESSURE RELIEF VALVE WITH MECHANICAL SHUTOFF

MAINTENANCE DRAWING DGC0141

Open the relief valve strainer flush valve (6) during every operation at 50-100 PSI supply pressure to insure foreign material is not blocking the screen.

The 3/32" diameter metering orifice and diaphragm chamber at (21) may be back-flushed if necessary while the pump is delivering water by opening the pilot head drain and placing valve handle (9) midway between ON and OFF position.

The relief valve, pilot unit, and strainer assemblies should be taken apart for inspection and cleaning at least annually, or as often as found necessary to insure trouble free performance.

To disassemble pilot head, first turn hand wheel (14) counter clockwise to remove spring compression. Remove the four 1/4" screws holding regulator spring housing (18). Lift out diaphragm (23) and pilot valve (51) assembly. Clean and make certain 3/32" diameter orifice hole is free of obstruction.

When reassembling pilot head, turn hand wheel (14) a few times clockwise to compress spring before tightening four screws holding spring housing. This will properly center valve seat and diaphragm.

The valve piston (40) and spring (44) chamber should be inspected and cleaned.

Replace diaphragm and o-rings if damaged or deteriorated.

Apply a thin coating of waterproof grease lubricant: to spring housing counterbore that guides the pilot valve (51) and ball (52), to end of tension screw (17), and between piston (40) and center post.

Self-cleaning strainer (63) can be removed for inspection or replacement by alternately turning valve knob (6) and stop nut (7) counter clockwise until stem is free for removal. To avoid discharging water through opening created by stem (62) removal, pump should be completely shut down before stem (62) is removed. Inspect and clean screen (63) if required. Check quad ring (64) for damage or deterioration. Reverse procedure to reassemble valve. Use care when initially inserting screen into body to avoid damaging quad ring (64) or valve seat.

To replace flush valve seat (69), remove stem/screen assembly, disconnect tubing lines attached to (61) body half and unscrew (61) body half from (70) body half. Replace (69) valve seat. Reverse procedure to reassemble valve.

All Darley relief valves can be provided with a micro switch and either one or two pilot lights to indicate when the valve is open or closed.

**IF FURTHER INFORMATION IS NEEDED, CALL W.S. DARLEY & CO. AT
CHIPPEWA FALLS, WI. AT 800-634-7812 or 715-726-2650**

REV.	DESCRIPTION	DATE	BY	CHKD.
1	ISSUED FOR PRODUCTION	04/15/13	J. W. HARRIS	J. W. HARRIS
2	REVISED FOR PRODUCTION	04/15/13	J. W. HARRIS	J. W. HARRIS
3	REVISED FOR PRODUCTION	04/15/13	J. W. HARRIS	J. W. HARRIS
4	REVISED FOR PRODUCTION	04/15/13	J. W. HARRIS	J. W. HARRIS

NO.	DESCRIPTION	QTY.
1	1/4" - 18 x 1.5	1
2	1/4" - 18 x 1.5	1
3	1/4" - 18 x 1.5	1
4	1/4" - 18 x 1.5	1
5	1/4" - 18 x 1.5	1
6	1/4" - 18 x 1.5	1
7	1/4" - 18 x 1.5	1
8	1/4" - 18 x 1.5	1
9	1/4" - 18 x 1.5	1
10	1/4" - 18 x 1.5	1
11	1/4" - 18 x 1.5	1
12	1/4" - 18 x 1.5	1
13	1/4" - 18 x 1.5	1
14	1/4" - 18 x 1.5	1
15	1/4" - 18 x 1.5	1
16	1/4" - 18 x 1.5	1
17	1/4" - 18 x 1.5	1
18	1/4" - 18 x 1.5	1
19	1/4" - 18 x 1.5	1
20	1/4" - 18 x 1.5	1
21	1/4" - 18 x 1.5	1
22	1/4" - 18 x 1.5	1
23	1/4" - 18 x 1.5	1
24	1/4" - 18 x 1.5	1
25	1/4" - 18 x 1.5	1
26	1/4" - 18 x 1.5	1
27	1/4" - 18 x 1.5	1
28	1/4" - 18 x 1.5	1
29	1/4" - 18 x 1.5	1
30	1/4" - 18 x 1.5	1
31	1/4" - 18 x 1.5	1
32	1/4" - 18 x 1.5	1
33	1/4" - 18 x 1.5	1
34	1/4" - 18 x 1.5	1
35	1/4" - 18 x 1.5	1
36	1/4" - 18 x 1.5	1
37	1/4" - 18 x 1.5	1
38	1/4" - 18 x 1.5	1
39	1/4" - 18 x 1.5	1
40	1/4" - 18 x 1.5	1
41	1/4" - 18 x 1.5	1
42	1/4" - 18 x 1.5	1
43	1/4" - 18 x 1.5	1
44	1/4" - 18 x 1.5	1
45	1/4" - 18 x 1.5	1
46	1/4" - 18 x 1.5	1
47	1/4" - 18 x 1.5	1
48	1/4" - 18 x 1.5	1
49	1/4" - 18 x 1.5	1
50	1/4" - 18 x 1.5	1
51	1/4" - 18 x 1.5	1
52	1/4" - 18 x 1.5	1
53	1/4" - 18 x 1.5	1
54	1/4" - 18 x 1.5	1
55	1/4" - 18 x 1.5	1
56	1/4" - 18 x 1.5	1
57	1/4" - 18 x 1.5	1
58	1/4" - 18 x 1.5	1
59	1/4" - 18 x 1.5	1
60	1/4" - 18 x 1.5	1
61	1/4" - 18 x 1.5	1
62	1/4" - 18 x 1.5	1
63	1/4" - 18 x 1.5	1
64	1/4" - 18 x 1.5	1
65	1/4" - 18 x 1.5	1
66	1/4" - 18 x 1.5	1
67	1/4" - 18 x 1.5	1
68	1/4" - 18 x 1.5	1
69	1/4" - 18 x 1.5	1
70	1/4" - 18 x 1.5	1
71	1/4" - 18 x 1.5	1
72	1/4" - 18 x 1.5	1
73	1/4" - 18 x 1.5	1
74	1/4" - 18 x 1.5	1
75	1/4" - 18 x 1.5	1
76	1/4" - 18 x 1.5	1
77	1/4" - 18 x 1.5	1
78	1/4" - 18 x 1.5	1
79	1/4" - 18 x 1.5	1
80	1/4" - 18 x 1.5	1
81	1/4" - 18 x 1.5	1
82	1/4" - 18 x 1.5	1
83	1/4" - 18 x 1.5	1
84	1/4" - 18 x 1.5	1
85	1/4" - 18 x 1.5	1
86	1/4" - 18 x 1.5	1
87	1/4" - 18 x 1.5	1
88	1/4" - 18 x 1.5	1
89	1/4" - 18 x 1.5	1
90	1/4" - 18 x 1.5	1
91	1/4" - 18 x 1.5	1
92	1/4" - 18 x 1.5	1
93	1/4" - 18 x 1.5	1
94	1/4" - 18 x 1.5	1
95	1/4" - 18 x 1.5	1
96	1/4" - 18 x 1.5	1
97	1/4" - 18 x 1.5	1
98	1/4" - 18 x 1.5	1
99	1/4" - 18 x 1.5	1
100	1/4" - 18 x 1.5	1

NO.	DESCRIPTION	QTY.
101	1/4" - 18 x 1.5	1
102	1/4" - 18 x 1.5	1
103	1/4" - 18 x 1.5	1
104	1/4" - 18 x 1.5	1
105	1/4" - 18 x 1.5	1
106	1/4" - 18 x 1.5	1
107	1/4" - 18 x 1.5	1
108	1/4" - 18 x 1.5	1
109	1/4" - 18 x 1.5	1
110	1/4" - 18 x 1.5	1

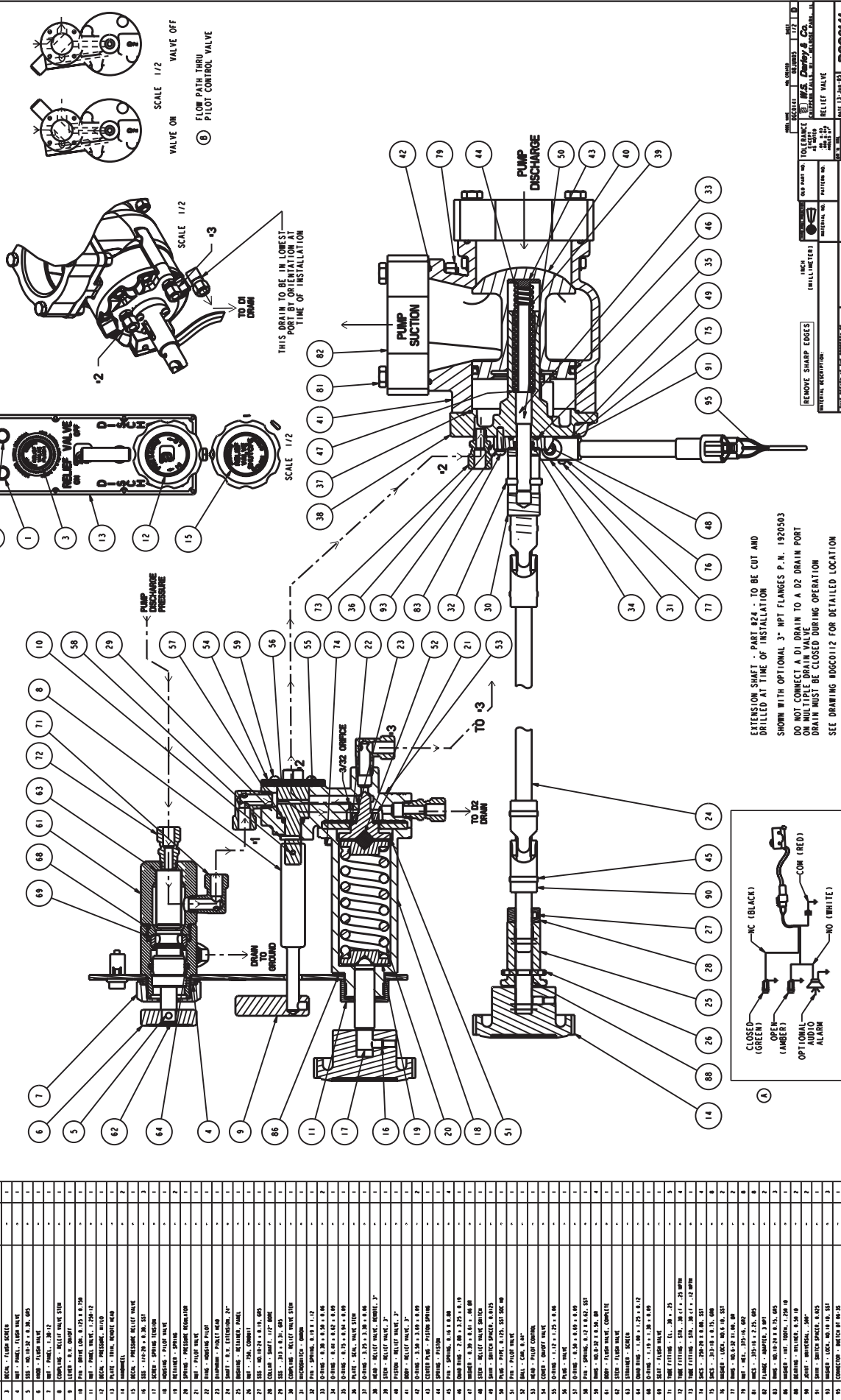

REV.	DESCRIPTION	DATE	BY	CHKD.
1	ISSUED FOR PRODUCTION	04/15/13	J. W. HARRIS	J. W. HARRIS
2	REVISED FOR PRODUCTION	04/15/13	J. W. HARRIS	J. W. HARRIS
3	REVISED FOR PRODUCTION	04/15/13	J. W. HARRIS	J. W. HARRIS
4	REVISED FOR PRODUCTION	04/15/13	J. W. HARRIS	J. W. HARRIS

REV.	DESCRIPTION	DATE	BY	CHKD.
1	ISSUED FOR PRODUCTION	04/15/13	J. W. HARRIS	J. W. HARRIS
2	REVISED FOR PRODUCTION	04/15/13	J. W. HARRIS	J. W. HARRIS
3	REVISED FOR PRODUCTION	04/15/13	J. W. HARRIS	J. W. HARRIS
4	REVISED FOR PRODUCTION	04/15/13	J. W. HARRIS	J. W. HARRIS

Rev 13
Date: 06/14/07
Rev Date: 02/11/11
1200525

Prepared By: EAS
Revised By: EAS
Approved By: TED

REV.	REVISIONS	DATE	CHK. NO.	APP. NO.

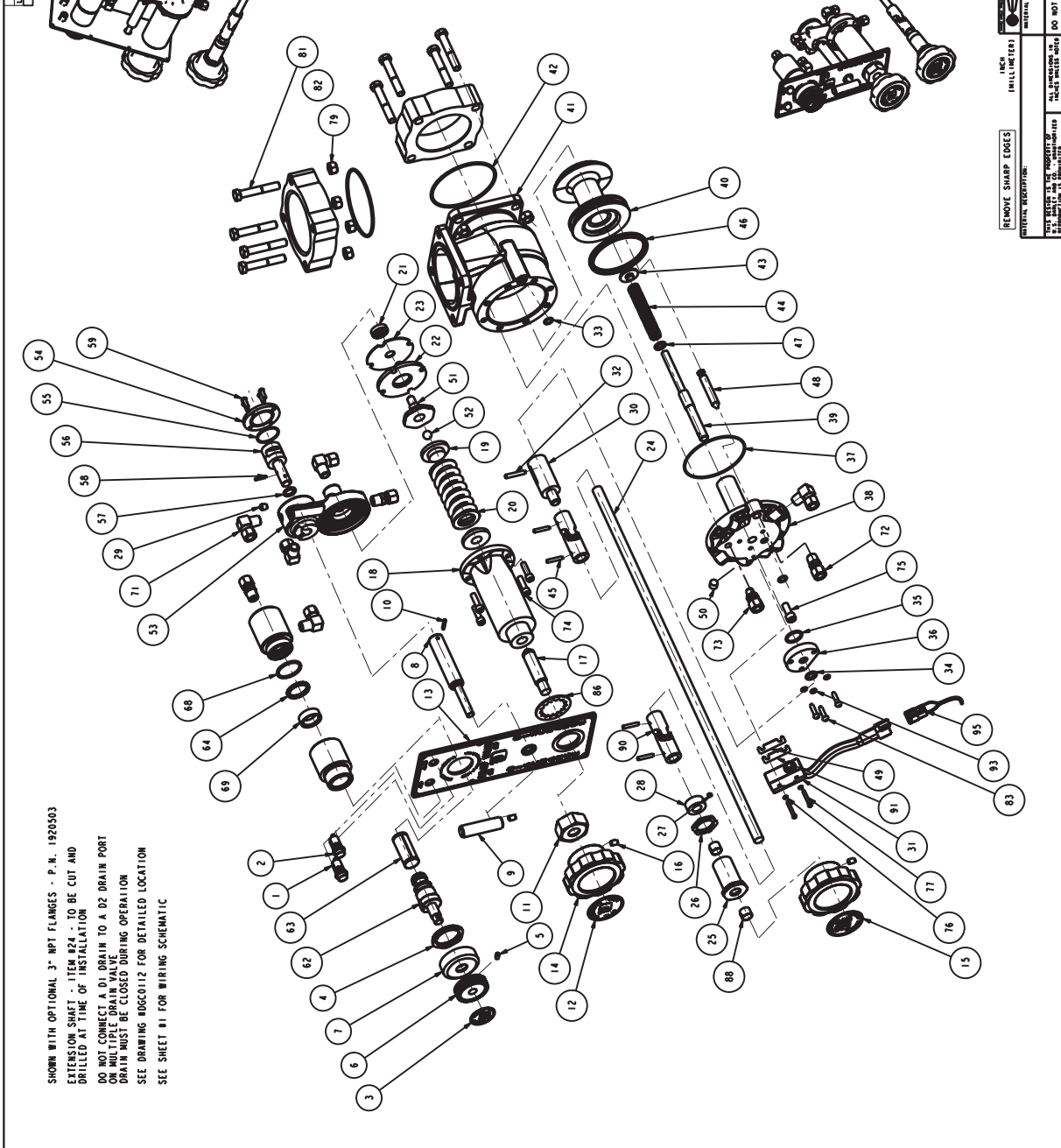

SHOWN WITH OPTIONAL 3" NPT FLANGES - P. N. 1920503
 EXTENSION SHAFT - ITEM 824 - TO BE CUT AND DRILLED AT TIME OF INSTALLATION
 DO NOT CONNECT A D1 DRAIN TO A D2 DRAIN PORT ON MULTIPLE DRAIN VALVE
 DRAIN MUST BE CLOSED DURING OPERATION
 SEE DRAWING 80GCO112 FOR DETAILED SCHEMATIC
 SEE SHEET 81 FOR WIRING SCHEMATIC

NO.	DESCRIPTION	PART NO.	QTY.
1	WASH. - 3/16" DIA. X 1/2" L.	1	1
2	WASH. - 3/16" DIA. X 1/2" L.	2	1
3	WASH. - 3/16" DIA. X 1/2" L.	3	1
4	WASH. - 3/16" DIA. X 1/2" L.	4	1
5	WASH. - 3/16" DIA. X 1/2" L.	5	1
6	WASH. - 3/16" DIA. X 1/2" L.	6	1
7	WASH. - 3/16" DIA. X 1/2" L.	7	1
8	WASH. - 3/16" DIA. X 1/2" L.	8	1
9	WASH. - 3/16" DIA. X 1/2" L.	9	1
10	WASH. - 3/16" DIA. X 1/2" L.	10	1
11	WASH. - 3/16" DIA. X 1/2" L.	11	1
12	WASH. - 3/16" DIA. X 1/2" L.	12	1
13	WASH. - 3/16" DIA. X 1/2" L.	13	1
14	WASH. - 3/16" DIA. X 1/2" L.	14	1
15	WASH. - 3/16" DIA. X 1/2" L.	15	1
16	WASH. - 3/16" DIA. X 1/2" L.	16	1
17	WASH. - 3/16" DIA. X 1/2" L.	17	1
18	WASH. - 3/16" DIA. X 1/2" L.	18	1
19	WASH. - 3/16" DIA. X 1/2" L.	19	1
20	WASH. - 3/16" DIA. X 1/2" L.	20	1
21	WASH. - 3/16" DIA. X 1/2" L.	21	1
22	WASH. - 3/16" DIA. X 1/2" L.	22	1
23	WASH. - 3/16" DIA. X 1/2" L.	23	1
24	WASH. - 3/16" DIA. X 1/2" L.	24	1
25	WASH. - 3/16" DIA. X 1/2" L.	25	1
26	WASH. - 3/16" DIA. X 1/2" L.	26	1
27	WASH. - 3/16" DIA. X 1/2" L.	27	1
28	WASH. - 3/16" DIA. X 1/2" L.	28	1
29	WASH. - 3/16" DIA. X 1/2" L.	29	1
30	WASH. - 3/16" DIA. X 1/2" L.	30	1
31	WASH. - 3/16" DIA. X 1/2" L.	31	1
32	WASH. - 3/16" DIA. X 1/2" L.	32	1
33	WASH. - 3/16" DIA. X 1/2" L.	33	1
34	WASH. - 3/16" DIA. X 1/2" L.	34	1
35	WASH. - 3/16" DIA. X 1/2" L.	35	1
36	WASH. - 3/16" DIA. X 1/2" L.	36	1
37	WASH. - 3/16" DIA. X 1/2" L.	37	1
38	WASH. - 3/16" DIA. X 1/2" L.	38	1
39	WASH. - 3/16" DIA. X 1/2" L.	39	1
40	WASH. - 3/16" DIA. X 1/2" L.	40	1
41	WASH. - 3/16" DIA. X 1/2" L.	41	1
42	WASH. - 3/16" DIA. X 1/2" L.	42	1
43	WASH. - 3/16" DIA. X 1/2" L.	43	1
44	WASH. - 3/16" DIA. X 1/2" L.	44	1
45	WASH. - 3/16" DIA. X 1/2" L.	45	1
46	WASH. - 3/16" DIA. X 1/2" L.	46	1
47	WASH. - 3/16" DIA. X 1/2" L.	47	1
48	WASH. - 3/16" DIA. X 1/2" L.	48	1
49	WASH. - 3/16" DIA. X 1/2" L.	49	1
50	WASH. - 3/16" DIA. X 1/2" L.	50	1
51	WASH. - 3/16" DIA. X 1/2" L.	51	1
52	WASH. - 3/16" DIA. X 1/2" L.	52	1
53	WASH. - 3/16" DIA. X 1/2" L.	53	1
54	WASH. - 3/16" DIA. X 1/2" L.	54	1
55	WASH. - 3/16" DIA. X 1/2" L.	55	1
56	WASH. - 3/16" DIA. X 1/2" L.	56	1
57	WASH. - 3/16" DIA. X 1/2" L.	57	1
58	WASH. - 3/16" DIA. X 1/2" L.	58	1
59	WASH. - 3/16" DIA. X 1/2" L.	59	1
60	WASH. - 3/16" DIA. X 1/2" L.	60	1
61	WASH. - 3/16" DIA. X 1/2" L.	61	1
62	WASH. - 3/16" DIA. X 1/2" L.	62	1
63	WASH. - 3/16" DIA. X 1/2" L.	63	1
64	WASH. - 3/16" DIA. X 1/2" L.	64	1
65	WASH. - 3/16" DIA. X 1/2" L.	65	1
66	WASH. - 3/16" DIA. X 1/2" L.	66	1
67	WASH. - 3/16" DIA. X 1/2" L.	67	1
68	WASH. - 3/16" DIA. X 1/2" L.	68	1
69	WASH. - 3/16" DIA. X 1/2" L.	69	1
70	WASH. - 3/16" DIA. X 1/2" L.	70	1
71	WASH. - 3/16" DIA. X 1/2" L.	71	1
72	WASH. - 3/16" DIA. X 1/2" L.	72	1
73	WASH. - 3/16" DIA. X 1/2" L.	73	1
74	WASH. - 3/16" DIA. X 1/2" L.	74	1
75	WASH. - 3/16" DIA. X 1/2" L.	75	1
76	WASH. - 3/16" DIA. X 1/2" L.	76	1
77	WASH. - 3/16" DIA. X 1/2" L.	77	1
78	WASH. - 3/16" DIA. X 1/2" L.	78	1
79	WASH. - 3/16" DIA. X 1/2" L.	79	1
80	WASH. - 3/16" DIA. X 1/2" L.	80	1
81	WASH. - 3/16" DIA. X 1/2" L.	81	1
82	WASH. - 3/16" DIA. X 1/2" L.	82	1
83	WASH. - 3/16" DIA. X 1/2" L.	83	1
84	WASH. - 3/16" DIA. X 1/2" L.	84	1
85	WASH. - 3/16" DIA. X 1/2" L.	85	1
86	WASH. - 3/16" DIA. X 1/2" L.	86	1
87	WASH. - 3/16" DIA. X 1/2" L.	87	1
88	WASH. - 3/16" DIA. X 1/2" L.	88	1
89	WASH. - 3/16" DIA. X 1/2" L.	89	1
90	WASH. - 3/16" DIA. X 1/2" L.	90	1
91	WASH. - 3/16" DIA. X 1/2" L.	91	1
92	WASH. - 3/16" DIA. X 1/2" L.	92	1
93	WASH. - 3/16" DIA. X 1/2" L.	93	1
94	WASH. - 3/16" DIA. X 1/2" L.	94	1
95	WASH. - 3/16" DIA. X 1/2" L.	95	1

REMOVE SHARP EDGES
 WITH FILE OR 100 GRIT SANDPAPER
 FINISH ALL SURFACES TO BE EXPOSED
 TO PREVENT CORROSION

NO PART NO. _____
 MATERIAL NO. _____
 SCALE _____

NO. _____
 DIMENSIONS IN _____
 TOLERANCES UNLESS OTHERWISE SPECIFIED

DATE 12-28-03
 DRAWN BY _____
 CHECKED BY _____

RELIEF VALVE
 SCALE 1/4

DGCO041

Prepared By: EAS
 Revised By: EAS
 Approved By: TED

REVISIONS	
REV. NO.	DATE
1	02/11/11
2	06/14/07
3	02/11/11

DO NOT CONNECT A D1 DRAIN TO A D2 DRAIN PORT ON MULTIPLE DRAIN VALVE. DRAIN MUST BE CLOSED DURING OPERATION. SEE DRAWING #DGC0112 FOR DETAILED LOCATION. SHOWN WITH OPTIONAL 3" NPT FLANGES - P.N. 1920503

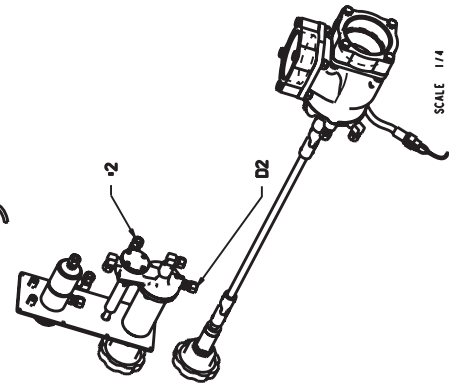
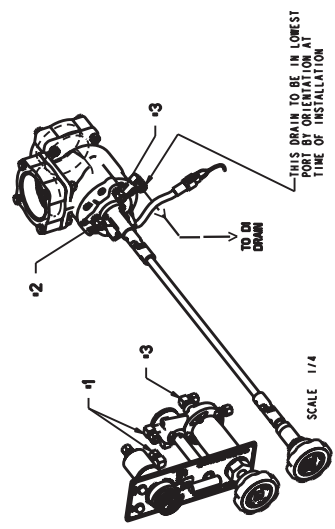
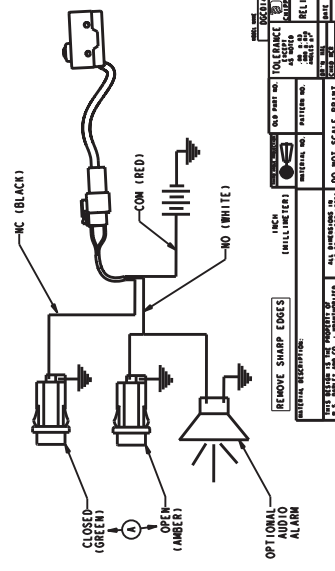
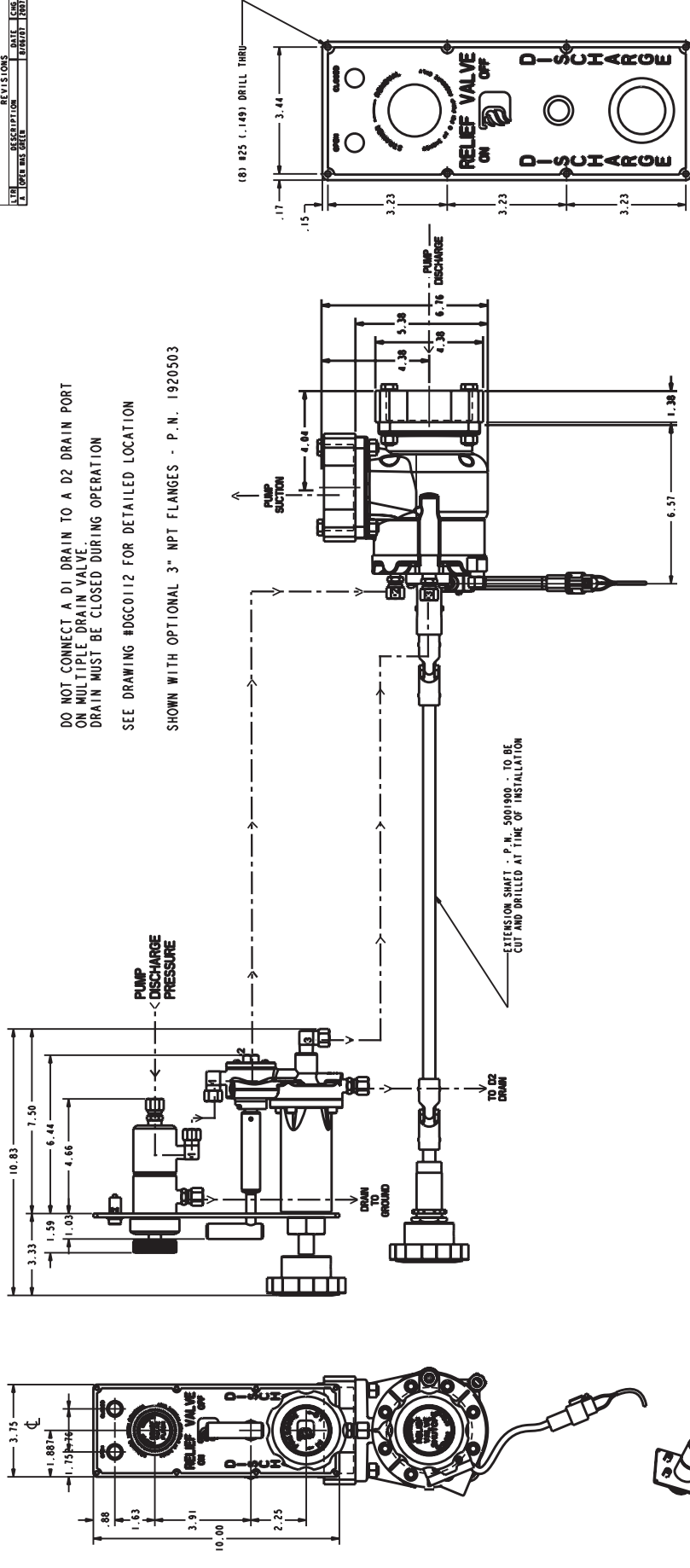

REV. NO.	DATE	BY	CHKD.
1	02/11/11		
2	06/14/07		
3	02/11/11		

DGC0112
 DRAIN VALVE
 SCALE 1/4
 DATE 02/11/11
 DRAWN BY
 CHECKED BY
 APPROVED BY
 ALL DIMENSIONS IN INCHES UNLESS NOTED OTHERWISE
 DO NOT SCALE PRINT
 REMOVE SHARP EDGES
 THIS DRAWING IS THE PROPERTY OF WESCAM CORPORATION
 IT IS TO BE USED ONLY FOR THE PROJECT AND QUANTITY SPECIFIED ON THE DRAWING

REV. NO.	DATE	BY	CHKD.
1	02/11/11		
2	06/14/07		
3	02/11/11		

DGC0112
 DRAIN VALVE
 SCALE 1/4
 DATE 02/11/11
 DRAWN BY
 CHECKED BY
 APPROVED BY
 ALL DIMENSIONS IN INCHES UNLESS NOTED OTHERWISE
 DO NOT SCALE PRINT
 REMOVE SHARP EDGES
 THIS DRAWING IS THE PROPERTY OF WESCAM CORPORATION
 IT IS TO BE USED ONLY FOR THE PROJECT AND QUANTITY SPECIFIED ON THE DRAWING

W.S. DARLEY & CO.

Relief Valve Alarm Installation Instruction

This Alarm is designed to concentrate audible sound in the operator zone only. For optimum Performance, position alarm sound opening so it is facing the operator at a distance of 24 - 36 inches.

Mount unit in 1.12 diameter panel hole. If panel is thicker than .09 inches, invert nut.

Do not mount with sound opening in an upward position. Do not obstruct opening.

Connect to 12 VDC only.

Two (2) wires are required to complete the circuit. The alarm is sensitive to polarity and will not operate if connected with polarity reversed.

Relief Valve Alarm Installation Instructions

THIS ALARM IS DESIGNED TO CONCENTRATE AUDIBLE SOUND IN THE OPERATOR ZONE ONLY. FOR OPTIMUM PERFORMANCE, POSITION ALARM SOUND OPENING SO IT IS FACING THE OPERATOR AT A DISTANCE OF 24-36 INCHES.

MOUNT UNIT IN 1.12 DIAMETER PANEL HOLE. IF PANEL IS THICKER THAN .09 IN., INVERT NUT.

DO NOT MOUNT WITH SOUND OPENING IN AN UPWARD POSITION. DO NOT OBSTRUCT OPENING.

CONNECT TO 12 VDC ONLY.

TWO (2) WIRES ARE REQUIRED TO COMPLETE THE CIRCUIT. THE ALARM IS SENSITIVE TO POLARITY AND WILL NOT OPERATE IF CONNECTED WITH POLARITY REVERSED.

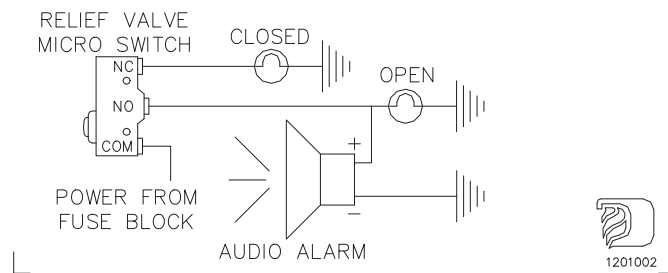

**IF FURTHER INFORMATION IS NEEDED, CALL W.S. DARLEY & CO. AT
CHIPPEWA FALLS, WI. AT 800-634-7812 or 715-726-2650**

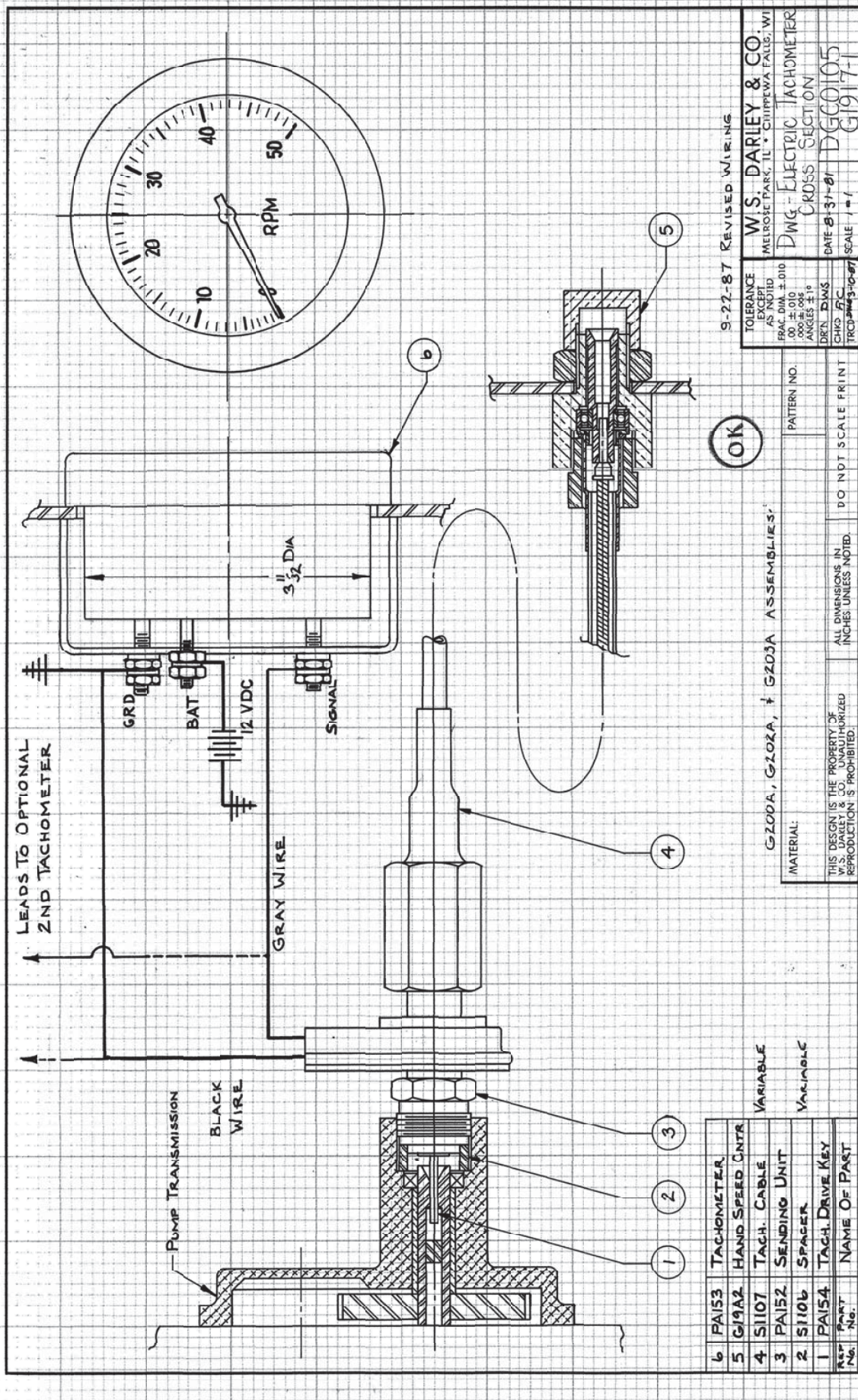

9-22-87 REVISED WIRING

W.S. DARLEY & CO.
METROSET PARK, IL • CHIPPewa FALLS, WI

DWG. - ELECTRIC TACHOMETER
CROSS SECTION

DATE 8-31-81 DGC0105
SCALE 1 = 1 G1917-T

TOLERANCE
EXCEPT
AS NOTED
FRAC. DIM. ± .010
DEC. DIM. ± .010
ANGLES ± 1°

DRAWN DIMS
CHKD P/C
TRC'D 10/15/87

PATTERN NO.

DO NOT SCALE PRINT

ALL DIMENSIONS IN INCHES UNLESS NOTED.

MATERIAL: G200A, G202A, & G203A ASSEMBLIES.

THIS DESIGN IS THE PROPERTY OF W.S. DARLEY & CO. UNAUTHORIZED REPRODUCTION IS PROHIBITED.

REF. PART No.	NAME OF PART	VAR.
6	PA153 TACHOMETER	
5	G19A2 HAND SPEED CNTR	
4	S1107 TACH. CABLE	VARIABLE
3	PA152 SENDING UNIT	
2	S1106 SPACER	VARIABLE
1	PA154 TACH. DRIVE KEY	

Rev 13
Date: 06/14/07
Rev Date: 02/11/11
1200525

Prepared By: EAS
Revised By: EAS
Approved By: TED

W.S. DARLEY & CO.

SWITCHING DIESEL TACHOMETER

1. CAUTION: Disconnect the battery during installation. Tighten nuts on back clamp only slightly more than you can tighten them with our fingers. Six inch pounds of torque is sufficient. Over tightening may result in damage to the instrument and may void your warranty!
2. Location: The tachometer should be located at least 18" from a magnetic compass. Some interference (erratic operation) may be noticed on the tachometer during radio transmission. This will neither damage a Faria tachometer nor affect accuracy when not transmitting.
3. Be certain to use insulated wire not less than 18 gauge that is approved for marine use. It is recommended that insulated wire terminals, preferably ring type, be used on all connections to the tachometer except for the light which requires a 1/4" female blade terminal.
4. The tach sender, DK-3 or equivalent, must be used in conjunction with the tachometer. One DK-3 sender will operate two tachometers. Mount the sender to the pump at the mechanical tachometer drive take-off using the correct drive tip (supplied with DK-3) to properly engage the sender.
5. Using a small screwdriver, SLIGHTLY depress and turn the selector switch on the back of the tachometer to match the tachometer drive take-off (see label on side of tachometer).
DEPRESSING THE SWITCH TOO HARD MAY CAUSE DAMAGE TO THE TACHOMETER.
Be sure the selector switch has locked into the detent at the correct position by slightly rotating the switch back and forth with the screwdriver. (PTO Pump tach ratio = 1/2, Midship Pump tach ratio = 1/1).
6. Cut a 3-3/8" diameter hole in the dash and mount the tach with back clamp supplied.
7. Connect a wire to the tach stud marked "BAT" (battery) and secure with nut and lockwasher. Connect opposite end of the 12 VDC circuit that is activated by the ignition switch.
8. Connect a wire to the tach stud marked "SIGNAL" and secure with a nut and lockwasher. Connect the opposite end to the gray wire of the diesel tachometer sender. Connect the black wire of the diesel tachometer sender to the engine ground.
9. Connect a wire to the tach stud marked "GND" (ground) and secure with a nut and lockwasher. Connect opposite end to the electrical ground.
10. Connect the blade terminal adjacent to the twist-out light assembly to the positive "+" side of the vehicle's instrument lighting circuit. No separate ground is required for lighting.
11. Reconnect the battery.
12. NOTE: To change light bulb, twist black socket assembly one-eighth (1/8) turn counter clockwise until it pops out. Bulb pulls straight out of socket assembly. It is a GE #158 instrument lamp.

**IF FURTHER INFORMATION IS NEEDED, CALL W.S. DARLEY & CO. AT
CHIPPEWA FALLS, WI. AT 800-634-7812 or 715-726-2650**



ATTACH WARNING PLATE
(ASSY AM00700) TO
CONTROL PANEL VIA
REV. NO. 96-115 (REF). ⓐ

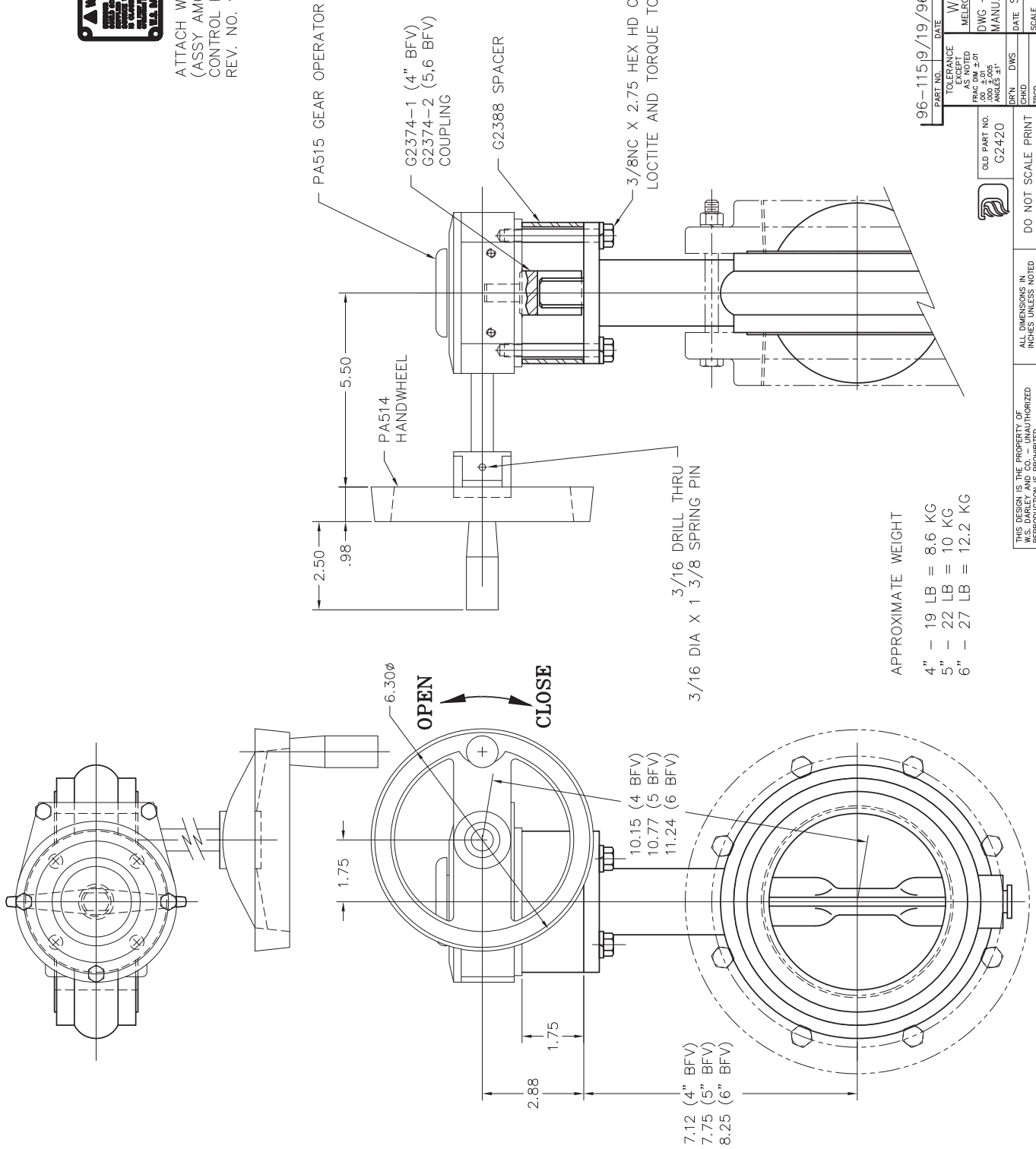

96-115/19/96 ⓐ ADDED PLATE LMH	
PART NO.	DATE
TOLERANCE UNLESS NOTED	
EXCEPT FRACTIONAL DIMENSIONS	
UNLESS SPECIFIED IN ANGLES ° ± .1	
UNLESS SPECIFIED IN ANGLES ° ± .1	
OLD PART NO.	DATE
G2420	SEP25/91
CHKD	DWS
TRCD	TRCD
SCALE	1/2

W.S. DARLEY & CO.
MICROSE, PARK, ILL. - CHIPPEWA FALLS, WI
DWG - BITRFLY VALVE ASSY
MANUAL CONTROLLED

DGD0104

DO NOT SCALE PRINT

ALL DIMENSIONS IN INCHES UNLESS NOTED

THIS DESIGN IS THE PROPERTY OF W.S. DARLEY & CO. UNAUTHORIZED REPRODUCTION IS PROHIBITED

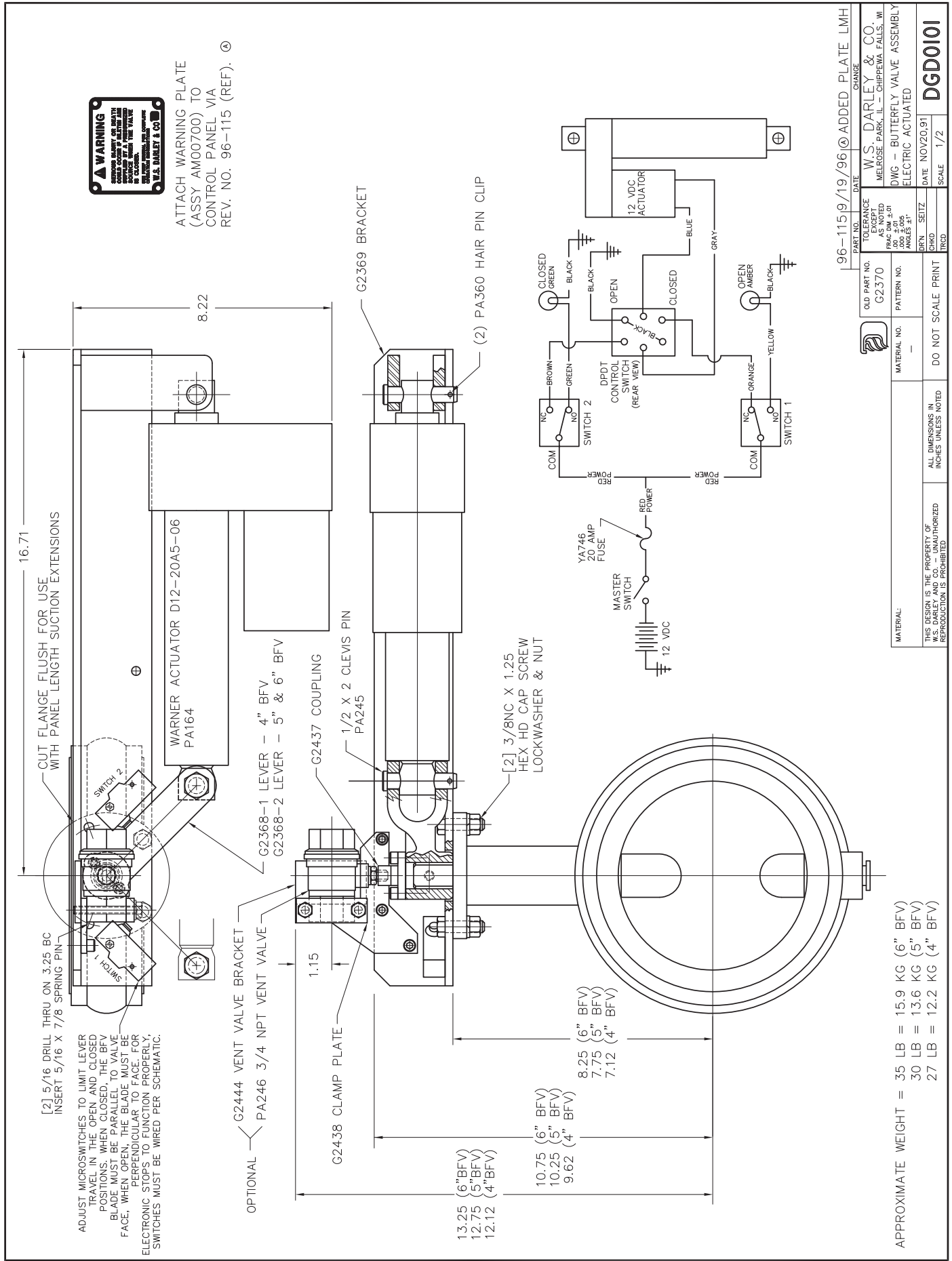

Prepared By: EAS
 Revised By: EAS
 Approved By: TED

96-115/19/96	ⓐ ADDED PLATE LMH
PART NO.	DATE
CHANGE	
OLD PART NO.	DATE
G2370	
TOLERANCE	AS NOTED
FRAC DIM	±.01
DEC DIM	±.005
ANGLES	±.1°
W.S. DARLEY & CO.	MELROSE PARK, IL - CHICPEWA FALLS, WI
DWG - BUTTERFLY VALVE ASSEMBLY	ELECTRIC ACTUATED
DATE	NOV20.91
DRN	SETZ
CHKD	
TRCD	
SCALE	1/2

MATERIAL:	ALL DIMENSIONS IN INCHES UNLESS NOTED	DO NOT SCALE	PRINT
MATERIAL NO.			
PATTERN NO.			
OLD PART NO.	G2370		
DATE			
DESIGN IS THE PROPERTY OF W.S. DARLEY & CO. UNAUTHORIZED REPRODUCTION IS PROHIBITED			

APPROXIMATE WEIGHT = 35 LB = 15.9 KG (6" BFV)
 30 LB = 13.6 KG (5" BFV)
 27 LB = 12.2 KG (4" BFV)

DGD0101

INLET RELIEF VALVE INFORMATION: (A)

ACTUAL PRESSURE RANGE IS 90PSI - 300PSI
 THERE MAY BE SOME DIMINISH IN FLOW AT HIGHER
 PRESSURE SETTINGS. (SETTINGS BELOW 200 PSI
 RECOMMENDED FOR MOST APPLICATIONS).
 RELIEF VALVE IS FACTORY SET AT 125 PSI AND
 WHEN PRESET AT 125 PSI, THE PRESSURE RELIEF
 VALVE SHALL NOT ALLOW A PRESSURE RISE GREATER
 THAN 60 PSI AT THE DEVICE INLET WHILE FLOWING A
 MINIMUM OF 150 GPM.
 THIS VALVE IS NFPA 2009 1901 COMPLIANT PER SECTION
 16.6.6.3

ADJUSTMENT INSTRUCTIONS (IF REQUIRED): (A)

ADJUST CENTER HEX COUNTERSUNK HEX HEAD PRESSURE
 ADJUSTING BOLT WITH A 1/4" ALLEN WRENCH, 9/16" OR
 14 MM SOCKET.
 TO SET AT THE DESIRED RELIEF PRESSURE, ADJUST THE ADJUSTING
 BOLT HEAD SO THE TOP OF THE BOLT HEAD IS EVEN WITH
 THE DESIRED PRESSURE.

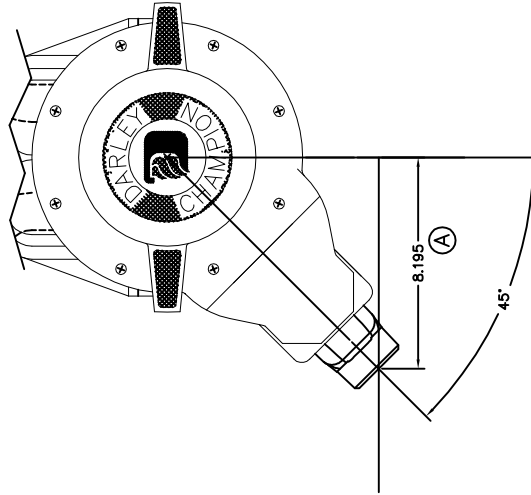

NOTE:
 SUCTION NIPPLE WILL BE ROTATED
 45° OFF CENTER WHEN MOUNTED.

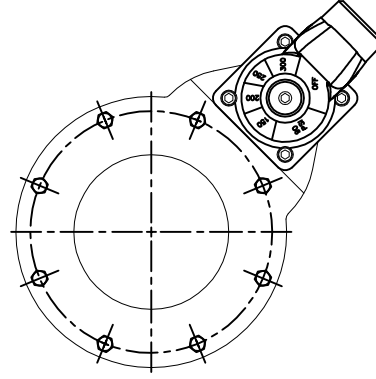
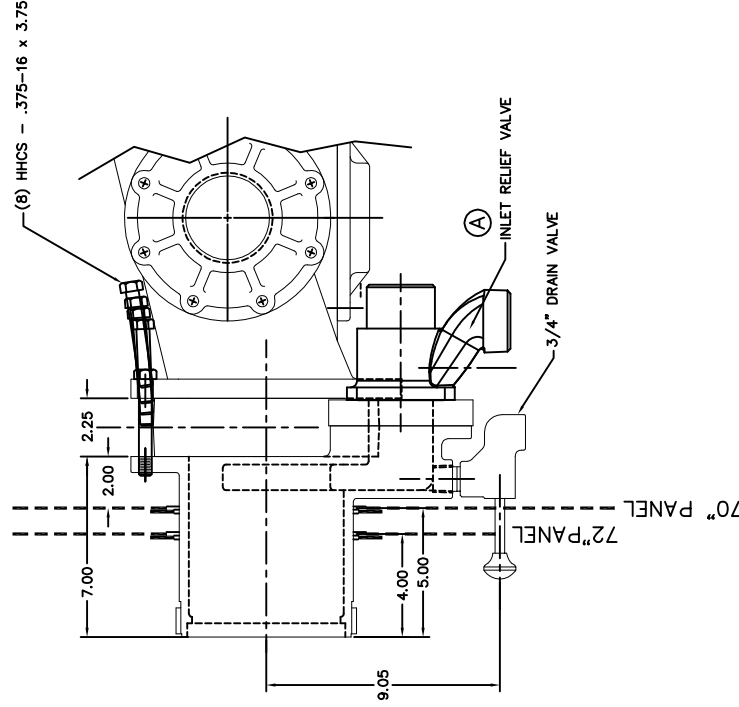

TYPICAL SUCTION EXTENSION CONFIGURATION FOR EM, LDM, N, & S PUMP

EXTENSION AND NIPPLE ARE THE SAME FOR 70 & 72" ASSEMBLIES WITH AND WITHOUT BUTTERFLY VALVES. IF BFV IS NOT REQUIRED, THEN KC00300 ASSY W/2.25 THICK SPACER IS USED. USE 1962503 STAINLESS STEEL PANEL TRIM RING



MATERIAL:
 THIS DESIGN IS THE PROPERTY OF W.S. DARLEY & CO. UNLESS AUTHORIZED REPRODUCTION IS PROHIBITED.
 DO NOT SCALE PRINT

07/18/12	DATE	UPDATED DRAWING TO REFLECT USE OF 8.20 WAS 5.22. UPDATED INFO AND ADJUSTMENT SECTION
A - #9312	PART NO.	W.S. DARLEY & CO.
	TOLERANCE EXCEPT AS NOTED	MELROSE PARK, IL - CHIPPENVA FALLS, WI
	FRAC DIM ±.01	INSTR - INLET RV ADJUSTMENT
	DEC DIM ±.005	
	ANGLES ±1°	
	DRN	DATE 03FEB,00
	CHKD S/L	SCALE 1/4
	TRGD	1200572

REVISIONS

LTR	DESCRIPTION	DATE	CHG. NO.	APPR'D
A	REVISED WIRING TO REFLECT HRNESS25FEB2009	06/22/10	5236	SMS
B	ADDED BUSHING, CLOSE NIPPLE, CHECK VALVE, AND NOTES TO MODEL AND DRAWING	06/22/10	6482	RJG

INSTALLATION INSTRUCTIONS:

- 1) INSTALL TEMPERATURE SWITCH ON SUCTION SIDE OF PUMP, AS NEAR TO IMPELLER AS POSSIBLE, PREFERABLY BETWEEN THE IMPELLER AND THE RELIEF VALVE.
- 2) INSTALL THE ACTUATOR VALVE ON THE DISCHARGE SIDE OF THE PUMP. ITS LOCATION IS NOT CRITICAL. IT CAN BE MOUNTED DIRECTLY TO THE PUMP OR POSITIONED REMOTELY AND CONNECTED WITH A 3/8" OD MINIMUM LINE.
- 3) VALVE DOES NOT NEED TO BE MOUNTED VERTICALLY AS SHOWN.
- 4) *PLUMB THE VALVE OUTLET TO TANK. IF DESIRED, USING 3/8" OD MINIMUM LINE. KEEP ALL LINES AS SHORT AS POSSIBLE.
- 5) ATTACH ONE LEAD OF VALVE TO THE TERMINAL ON THE TEMPERATURE SWITCH. ATTACH THE OTHER LEAD TO A FUSED VOLTAGE SOURCE. IF DESIRED, THE TEMPERATURE SWITCH CAN ALSO BE USED TO CONTROL A LIGHT ON THE PANEL NOTIFYING THE OPERATOR THAT OVERHEATING IS OCCURRING AND THE UNIT HAS BEEN ACTIVATED.
- 6) TO TEST THE VALVE: WITH PUMP RUNNING, JUMP THE TERMINALS ON THE TEMPERATURE SWITCH. IF THE VALVE DOES NOT DISCHARGE, IT MAY BE INSTALLED BACKWARDS OR WIRING CONNECTIONS MAY BE INCORRECT.
- * CONNECTION TO TANK MAY CAUSE TANK TO OVERHEAT, REDUCING THE EFFECTIVENESS OF THIS DEVICE. TO PREVENT FREEZING DAMAGE, WHEN CONNECTING TO TANK, THE VALVE SHOULD BE MOUNTED ON THE TANK, BUT ABOVE THE PUMP. IF THE VALVE IS TO DISCHARGE TO ATMOSPHERE, THE VALVE SHOULD BE MOUNTED ON, OR AS CLOSE TO THE PUMP AS POSSIBLE.

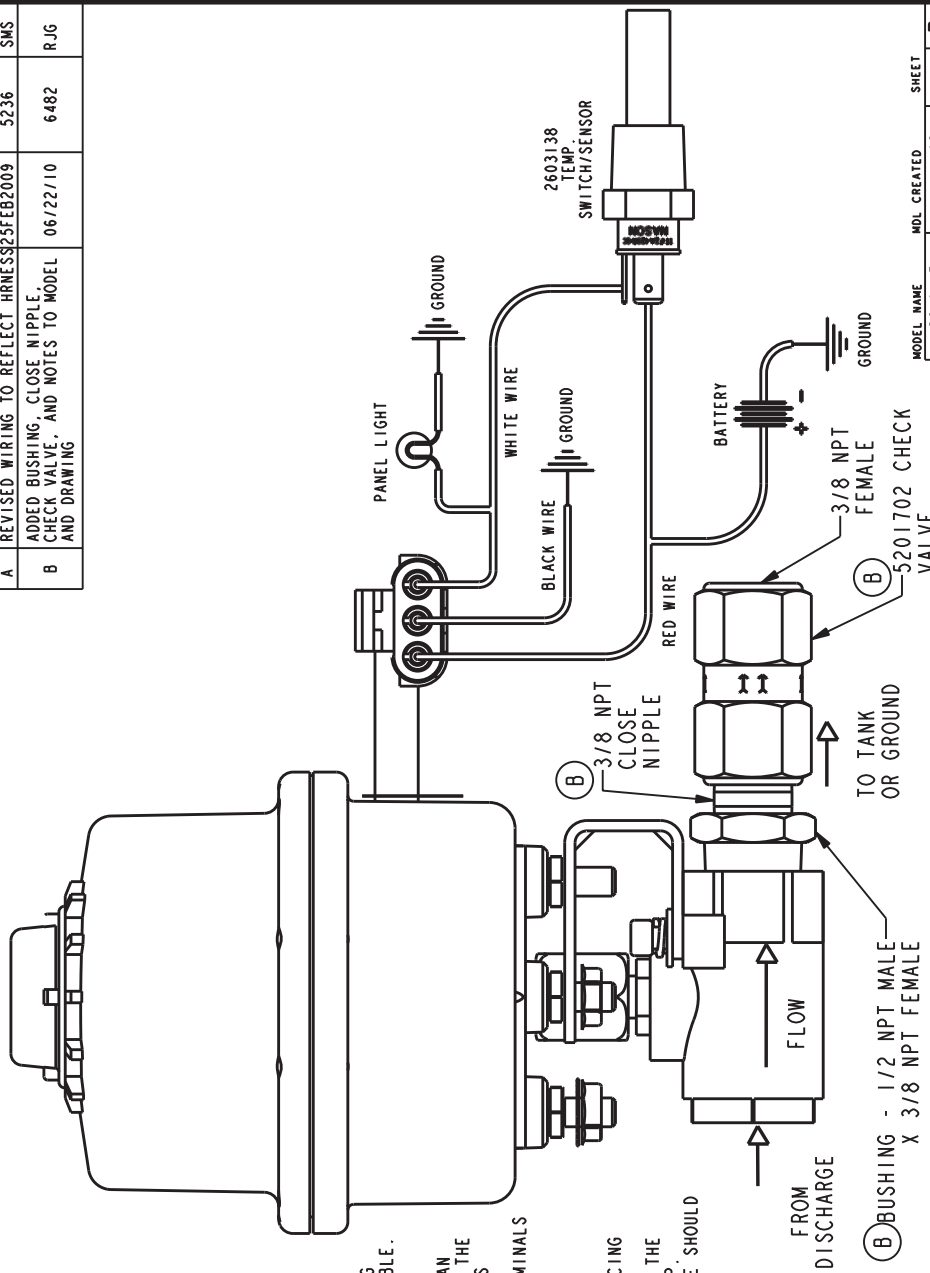

TOLERANCE EXCEPT AS NOTED 0.00 ± 0.03 0.000 ± 0.010 ANGLES ± 1°		OLD PART NO.		PATTERN NO.	
MATERIAL NO.		INCH (MILLIMETER)		DO NOT SCALE PRINT	
REMOVE SHARP EDGES		THIS DESIGN IS THE PROPERTY OF W.S. DARLEY AND CO. - UNAUTHORIZED REPRODUCTION IS PROHIBITED		SCALE	
MATERIAL DESCRIPTION:		DATE 14-NOV-08		1/1	
FITTED W/ABLE PROJECTION		MODEL NAME		SHEET	
W.S. Darley & Co. TIASCA, IL - CHIPPEWA FALLS, WI		DGM0117		11/14/08 1/1 B	
DWG - THERMAL RELIEF SYSTEM KZCO VALVE, 2603138 TEMP. SENSOR		DGM0117		1/1	

REVISIONS

LTR	DESCRIPTION	DATE	CHG NO.	APPR'D

SUPPLIED BY KZCO

White: Switched 12 VDC (+) = Relay Energized "OPEN"
 Black: Constant 12 VDC (-)
 Red: Constant 12 VDC (+)

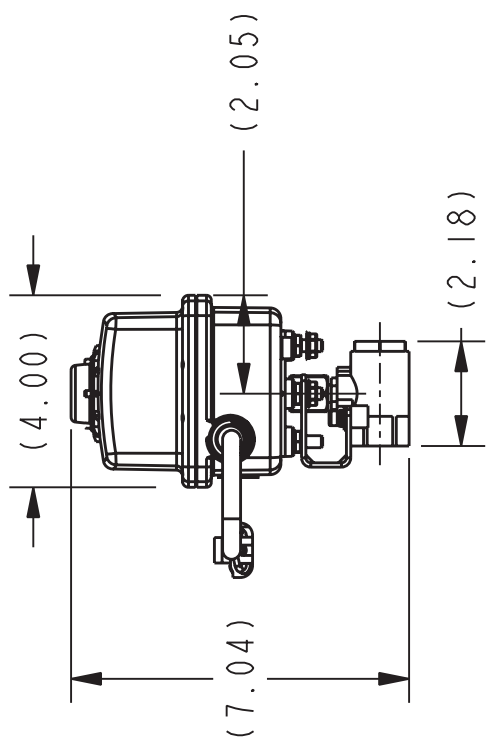
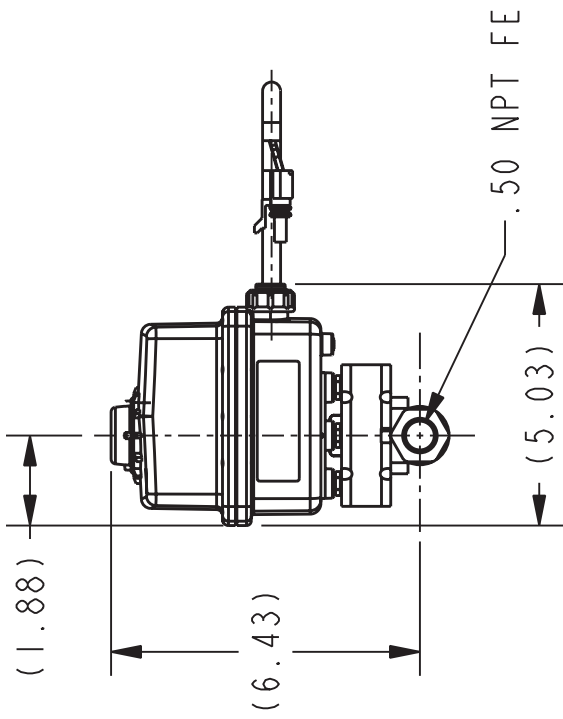
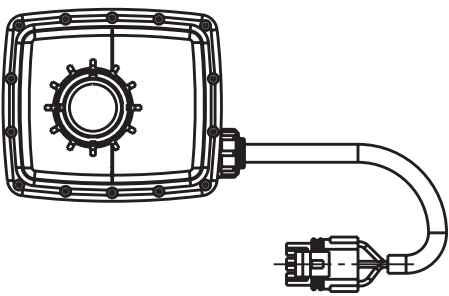
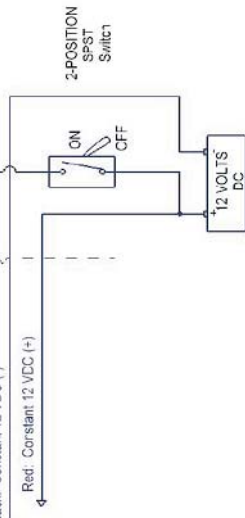

REMOVE SHARP EDGES

INCH
[MILLIMETER]

MATERIAL DESCRIPTION:
KZCO 84D23-10D20-PO1

THIS DESIGN IS THE PROPERTY OF
W.S. DARLEY AND CO. - UNAUTHORIZED
REPRODUCTION IS PROHIBITED



MATERIAL NO. -
PATTERN NO. -

OLD PART NO. -

TOLERANCE
EXCEPT
AS NOTED
.00 ±.03
.000 ±.010
ANGLES ±1°

DR 'N R/JG
CHKD DWS
TRCD

DO NOT SCALE PRINT

MODEL NAME 5209401 MDL CREATED 11/13/08 SHEET 1/2 A

W.S. Darley & Co.
ITASCA, IL - CHIPPEWA FALLS, WI

VALVE - ACTUATED, 12VDC, .50NPT FE
KZCO 84D23-10D20-PO1

DATE 13-Nov-08
SCALE 1/4
5209401

REVISED	7/15/2008 9:4 5:57 AM	REVISIONS	REVISED BY
-29			log (checked)

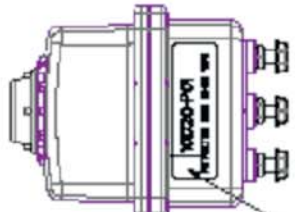

ACTUATOR LABEL
 MAX500 LABEL DESCRIPTION
 ACTUATOR, EH3 12/24 VDC

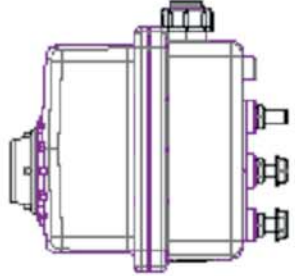

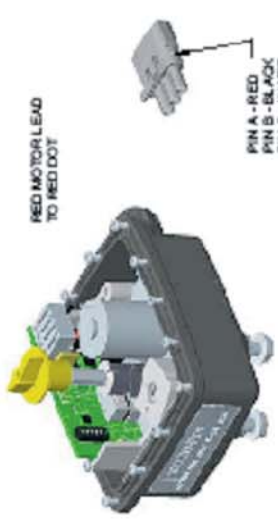

RED MOTOR LEAD
 TO RED DOT

PIN A - RED
 PIN B - BLACK
 PIN C - WHITE

INPUT/OUTPUT
 POWER = 1224 VDC
 1 - BLACK - POWER (-) NEGATIVE
 2 - RED - POWER (+) POSITIVE
 3 - WHITE - SIGNAL (+) POSITIVE TO OPEN
 4 - -

DIP SWITCH 'ON'

SCALE .500

PROGRAM NOTE:

MAX500 SET DATA
 CONTROL INPUT = 1
 FEEDBACK = 0
 OPERATOR = 0
 MOTOR = HZ
 SPEED CT = 0.8
 ZEROSET = 0.5
 RANGE TOLERANCE = 1
 ROTATION = 00192
 ACTUATOR RANGE = 0.0010.00
 DESIGN VOLTAGE = E
 DIP SW = 3
 LABEL = 10200
 OPTIONS = 0
 PLUS TYPE = P
 TEST PLUG =

21	1	EH-502	LABEL, EH ACTUATOR, 2.8" X 1.5", THERMAL TRANSFER, WHITE	NO MATERIAL
29	1	800319	HARNESSES, 6BA, 38FT, WP312.5"	POLYPROPYLENE, TAJIC, 20
19	1	EH3-115-Y	FLANGS, YELLOW	
18	1	1591-00219	PCB ASSY, EH3 L3 SOLID STATE 12 VDC	
17	1	100-801	GEAR MOTOR, M2, 8RPM/MOLON	NO MATERIAL
16	3	03-2-22	NUT, HEX HEAD, serrated FLANGE, .2610-20 UNC-.25	STAINLESS STEEL, TYPE 303
15	4	EH3-135	STUD, 1/4-20 X 1.0 MTG	STAINLESS STEEL, TYPE 303
14	1	EH-104	RETAINER, PUSH ON 5/16" SHAFT	STAINLESS STEEL, TYPE 304
13	1	494-0100	CAM ASSY, EXTD LOD FOR EH3S EQUIP	NO MATERIAL
12	1	EH-502	LABEL, EH ACTUATOR, 2.8" X 1.5", THERMAL TRANSFER, WHITE	SILICONE, RED, 0.5 DURAMETER
11	1	EH-139	O-RING, DOME	POLYURETHANE,
10	1	EH3-114	DOME, CLEAR	
9	14	EHPT-1103	SCREW, PAN, PHILLIPS, HIGH-LOW, 5-2.0 X .562	STAINLESS STEEL, TYPE, A4
8	1	EH3-100-14	LID, CASE, EH3, DOME	NYLON DPC, 6033L, BLACK
7	4	EH3-100	SCREW, 8-32 X 1.25 PHRMS SS	STAINLESS STEEL, TYPE, 18-8
6	1	EH-107	SCREW, 8-18 X.98" T58 PH155	STAINLESS STEEL, TYPE, 18-8
5	1	EH3-1030	O-RING, EH3, CASE LID, # 00	SILICONE, RED, 0.5 DURAMETER
4	1	EH-139	O-RING, 80R, PRESSURE TEST PORT	FLUOROCARBON/BLACK, DURAMETER
3	1	EHPT-140	O-RING, #12, MOTOR SHAFT, VITON	FLUOROCARBON/BLACK, DURAMETER
2	1	EH3-10034H	LOWER CASE - EH3 INTERNAL MTG	NYLON DPC, 6033-LBLACK
1	1	498-0002	CASE KIT, EH3 IM DOME NYLON MC MTR	NYLON

REVISED BY: EAS
 DATE: 06/14/07
 REVISED BY: TED
 DATE: 02/11/11

MAX500
 PART NO: 1002(P01)
 SCALE: 500
 MATERIAL: NYLON

DESIGNER: A. KOTTAS
 CHECKED: J. B. BROWN
 APPROVED: J. B. BROWN

DATE: 2008-05-29
 DESIGNED: GERRILL, ERIC/CAMP
 DRAWN: PEDDE
 PART NO: 1002(P01)
 SCALE: 500
 MATERIAL: NYLON

MAX500
 PART NO: 1002(P01)
 SCALE: 500
 MATERIAL: NYLON

REVISIONS			
LTR	DESCRIPTION	DATE	CHG NO. APPR'D

60AD WIRING
Standard On/Off applications, SPST Switch
24 VDC

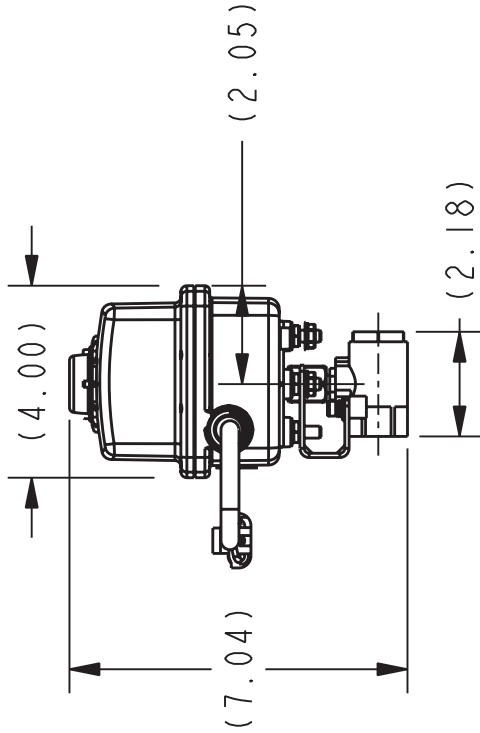
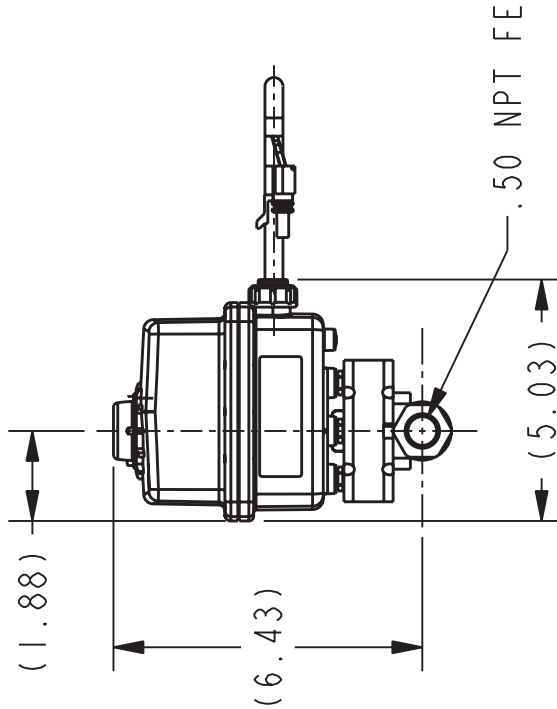
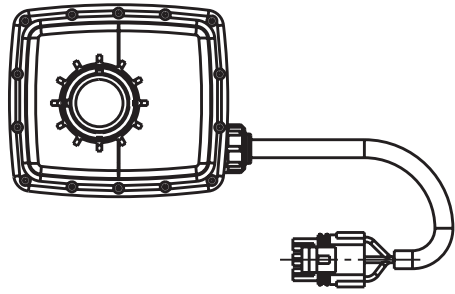
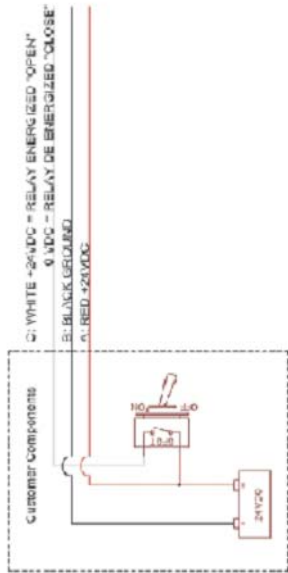

MODEL NAME		MDL CREATED		SHEET	
5209402		11/13/08		1/3 A	
W.S. Darley & Co. ITASCA, IL - CHIPPEWA FALLS, WI					
VALVE - ACTUATED, 24VDC, .50NPT FE KZCO 84D23-60AD-M					
TOLERANCE EXCEPT AS NOTED		DR 'N		R/JG	
.00 ±.03		CHKD		DWS	
.000 ±.010		TRCD		1/4	
ANGLES ±1°		DATE		13-NOV-08	
OLD PART NO.		PATTERN NO.		SCALE	
-		-		1/4	
THIRD ANGLE PROJECTION		MATERIAL NO.		DO NOT SCALE PRINT	
		-		-	
INCH [MILLIMETER]		MATERIAL DESCRIPTION:		ALL DIMENSIONS IN INCHES UNLESS NOTED	
-		KZCO 84D23-60AD-M		-	
REMOVE SHARP EDGES		THIS DESIGN IS THE PROPERTY OF W.S. DARLEY AND CO. - UNAUTHORIZED REPRODUCTION IS PROHIBITED		5209402	

REVISION	REVISION ECO	REVISION/REVISION DATE	REVISION/REVISION BY
001	.1	3/28/2008 1:49:38 PM	wfcedde

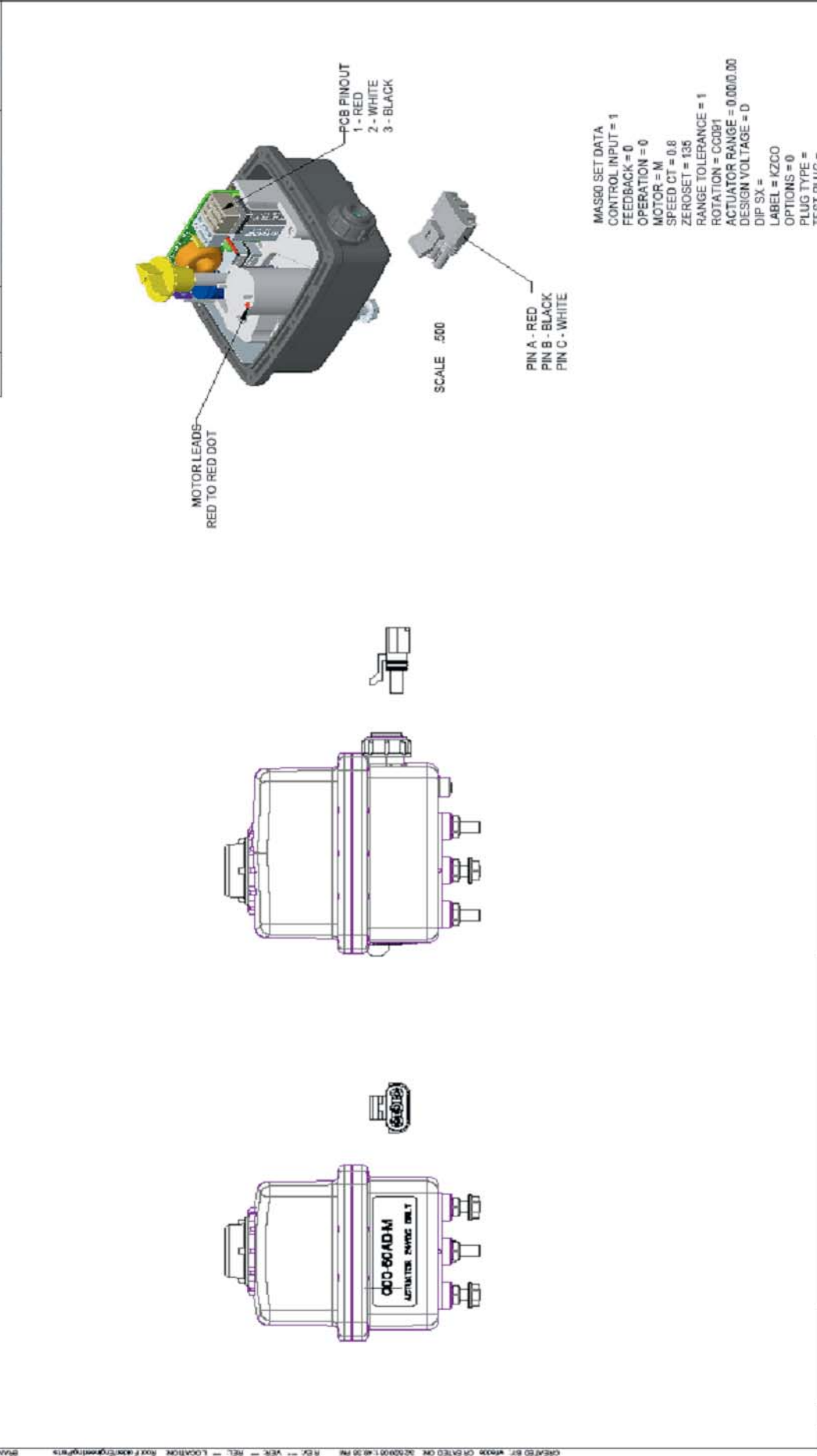

8	1	EH-502	LABEL, EH ACTUATOR, 2.5" X 1", THERMAL TRANSFER, WHITE	NO MATERIAL
7	2	QX-222	NUT, HEX HEAD, SERRATED FLANGE, .256-28 UNC-2B	STAINLESS STEEL, TYPE 303
6	4	EH3-135	STUD, 1/4-20 X 1/2 MTG	STAINLESS STEEL, TYPE 303
5	1	800018	HARNES, 60A, 3ST, WPST, 22.5"	
4	1	EH3-115-Y	FLAG, YELLOW	POLYPROPYLENE, TALC_20
3	1	800468	PCB ASSY, EH3 24VDC 60AD/60DF	
2	1	EH3-110	GEAR ASSY, EH3 SERIES M1 18 RPM @ 12VDC	
1	1	495-0005	CASE KIT, EH3 IM DOME NYLON M1 & N1 MTR	
DET 001			DESCRIPTION	MATERIAL

DATE:	2007-04-10
DESIGNED:	L. ERDKAMP
DRAWN:	W. FEDDE
APPROVED:	A. KOTTAS
SCALE:	.500
SIZE:	B
MATERIAL:	

STANDARD TOLERANCES:	
- ALL DIMENSIONS IN INCHES UNLESS NOTED	
TOTAL FINISH	300.75
DRILL	300.75
SURFACE FINISH	300.75
3X .125	300.75
3X .125	300.75
DENSITY:	ANY DIMENSION
SUPPLY:	ANY DIMENSION
MASS:	300.75
VOLUME:	1200.00

KZCO inc.
2380 W PARKWAY
GREENWOOD, NC 28036 USA
TEL: 704.834.2222 FAX: 704.834.2222

TITLE: ACTUATOR EH3 .8S @24VDC

REF: PART NO: 000-60AD-M

REVISION: 001

DRAWING NO: 000-60AD-M

SHEET: 1 OF 1

Prepared By: EAS
Revised By: EAS
Approved By: TED

REVISED BY	REVISION DATE	REVISION DESCRIPTION	REVISED BY
-6+	8/12/2008 9:18:50 AM		kgotschal

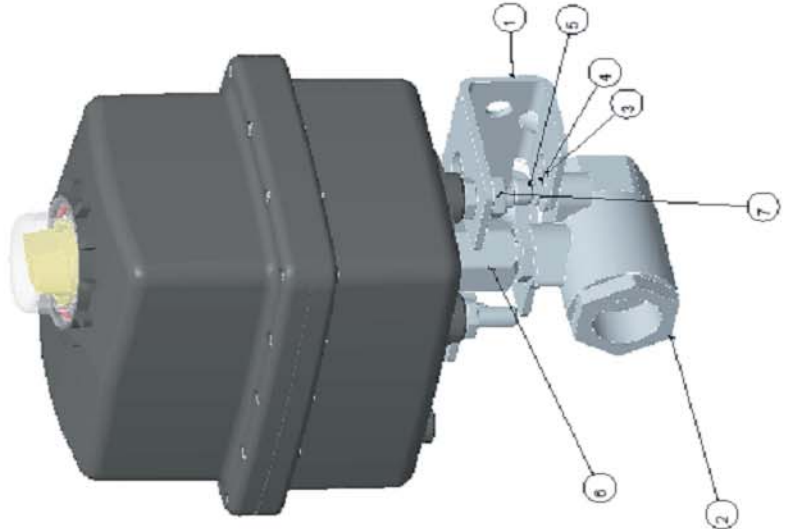
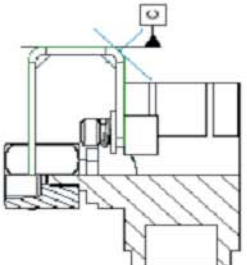
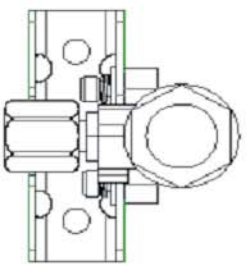
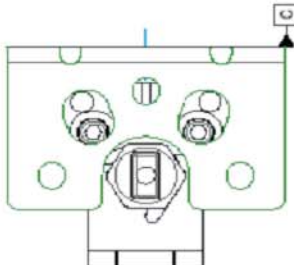

ACTUATOR SHOWN IS REPRESENTATIVE USED
 ONLY TO SHOW PROPER ORIENTATION TO VALVE.

7	3	QK-222	NUT, HEX HEAD, SERRATED FLANGE, 250-20 UNC-2B	STAINLESS STEEL TYPE 303
6	1	BH-146	COUPLER, 1/4" - 1/2" APOLLO	STAINLESS STEEL TYPE 316
5	2	BH-158	SCREW, #10-24 X 3/8" SS SOCKET HEAD	STAINLESS STEEL TYPE 303 OR 316
4	2	BHPT-153	WASHER, LOCK, 197 ID X .334 OD X .047 T	STAINLESS STEEL TYPE 316
3	2	BHPT-150	WASHER, FLAT, #10 18-8 SS	STAINLESS STEEL TYPE 316
2	1	EHS-540	VALVE, 1/2" 2-WAY APOLLO 7D-102-01 BRONZE BALL VALVE	BRONZE
1	1	BSP-174	BRACKET, MOUNTING EHS SERIES	STAINLESS STEEL TYPE 304
DET QTY		PART NUMBER	DESCRIPTION	MATERIAL

DESIGNER	DATE	DESIGNED BY	DATE	DESIGNED BY	DATE
APPROVED	2007-06-08	L. ERDKAMP	2007-06-08	L. ERDKAMP	2007-06-08
		C. HOWARD		C. HOWARD	
		L. ERDKAMP		L. ERDKAMP	
		SCALE: T50		SCALE: T50	
		SIZE: B		SIZE: B	
		MATERIAL: AS NOTED		MATERIAL: AS NOTED	

STANDARD TOLERANCES - ALL DIMENSIONS IN INCHES UNLESS NOTED:	FINISHES:
FRACTIONS: 1/32, 1/16, 1/8, 1/4, 1/2, 3/4, 1, 2, 3, 4, 6, 8, 12, 16, 24, 36, 48	INTERNAL: 125 RA
DECIMALS: .005, .010, .015, .020, .030, .040, .050, .060, .070, .080, .090, .100, .125, .150, .175, .200, .250, .300, .375, .400, .500, .625, .750, .875, 1.000, 1.250, 1.500, 1.750, 2.000, 2.500, 3.000, 3.750, 4.000, 5.000, 6.000, 7.500, 8.000, 10.000, 12.000, 15.000, 20.000, 25.000, 30.000, 36.000, 45.000, 60.000, 75.000, 90.000, 100.000, 120.000, 150.000, 180.000, 200.000, 240.000, 300.000, 360.000, 450.000, 600.000, 750.000, 900.000, 1000.000	EXTERNAL: 125 RA
	THREADS: 2-6 UNF-2A, 1/2-20 UNF-2A, 1/4-20 UNF-2A, 3/16-32 UNF-2A, 1/8-32 UNF-2A, 1/4-28 UNF-2A, 3/8-32 UNF-2A, 1/2-28 UNF-2A, 3/4-24 UNF-2A, 1-1/2-12 UNF-2A, 2-1/2-12 UNF-2A, 3-1/2-12 UNF-2A, 4-1/2-12 UNF-2A, 6-1/2-12 UNF-2A, 8-1/2-12 UNF-2A, 10-1/2-12 UNF-2A, 12-1/2-12 UNF-2A, 14-1/2-12 UNF-2A, 16-1/2-12 UNF-2A, 18-1/2-12 UNF-2A, 20-1/2-12 UNF-2A, 22-1/2-12 UNF-2A, 24-1/2-12 UNF-2A, 26-1/2-12 UNF-2A, 28-1/2-12 UNF-2A, 30-1/2-12 UNF-2A, 32-1/2-12 UNF-2A, 34-1/2-12 UNF-2A, 36-1/2-12 UNF-2A, 38-1/2-12 UNF-2A, 40-1/2-12 UNF-2A, 42-1/2-12 UNF-2A, 44-1/2-12 UNF-2A, 46-1/2-12 UNF-2A, 48-1/2-12 UNF-2A, 50-1/2-12 UNF-2A, 52-1/2-12 UNF-2A, 54-1/2-12 UNF-2A, 56-1/2-12 UNF-2A, 58-1/2-12 UNF-2A, 60-1/2-12 UNF-2A, 62-1/2-12 UNF-2A, 64-1/2-12 UNF-2A, 66-1/2-12 UNF-2A, 68-1/2-12 UNF-2A, 70-1/2-12 UNF-2A, 72-1/2-12 UNF-2A, 74-1/2-12 UNF-2A, 76-1/2-12 UNF-2A, 78-1/2-12 UNF-2A, 80-1/2-12 UNF-2A, 82-1/2-12 UNF-2A, 84-1/2-12 UNF-2A, 86-1/2-12 UNF-2A, 88-1/2-12 UNF-2A, 90-1/2-12 UNF-2A, 92-1/2-12 UNF-2A, 94-1/2-12 UNF-2A, 96-1/2-12 UNF-2A, 98-1/2-12 UNF-2A, 100-1/2-12 UNF-2A, 102-1/2-12 UNF-2A, 104-1/2-12 UNF-2A, 106-1/2-12 UNF-2A, 108-1/2-12 UNF-2A, 110-1/2-12 UNF-2A, 112-1/2-12 UNF-2A, 114-1/2-12 UNF-2A, 116-1/2-12 UNF-2A, 118-1/2-12 UNF-2A, 120-1/2-12 UNF-2A, 122-1/2-12 UNF-2A, 124-1/2-12 UNF-2A, 126-1/2-12 UNF-2A, 128-1/2-12 UNF-2A, 130-1/2-12 UNF-2A, 132-1/2-12 UNF-2A, 134-1/2-12 UNF-2A, 136-1/2-12 UNF-2A, 138-1/2-12 UNF-2A, 140-1/2-12 UNF-2A, 142-1/2-12 UNF-2A, 144-1/2-12 UNF-2A, 146-1/2-12 UNF-2A, 148-1/2-12 UNF-2A, 150-1/2-12 UNF-2A, 152-1/2-12 UNF-2A, 154-1/2-12 UNF-2A, 156-1/2-12 UNF-2A, 158-1/2-12 UNF-2A, 160-1/2-12 UNF-2A, 162-1/2-12 UNF-2A, 164-1/2-12 UNF-2A, 166-1/2-12 UNF-2A, 168-1/2-12 UNF-2A, 170-1/2-12 UNF-2A, 172-1/2-12 UNF-2A, 174-1/2-12 UNF-2A, 176-1/2-12 UNF-2A, 178-1/2-12 UNF-2A, 180-1/2-12 UNF-2A, 182-1/2-12 UNF-2A, 184-1/2-12 UNF-2A, 186-1/2-12 UNF-2A, 188-1/2-12 UNF-2A, 190-1/2-12 UNF-2A, 192-1/2-12 UNF-2A, 194-1/2-12 UNF-2A, 196-1/2-12 UNF-2A, 198-1/2-12 UNF-2A, 200-1/2-12 UNF-2A, 202-1/2-12 UNF-2A, 204-1/2-12 UNF-2A, 206-1/2-12 UNF-2A, 208-1/2-12 UNF-2A, 210-1/2-12 UNF-2A, 212-1/2-12 UNF-2A, 214-1/2-12 UNF-2A, 216-1/2-12 UNF-2A, 218-1/2-12 UNF-2A, 220-1/2-12 UNF-2A, 222-1/2-12 UNF-2A, 224-1/2-12 UNF-2A, 226-1/2-12 UNF-2A, 228-1/2-12 UNF-2A, 230-1/2-12 UNF-2A, 232-1/2-12 UNF-2A, 234-1/2-12 UNF-2A, 236-1/2-12 UNF-2A, 238-1/2-12 UNF-2A, 240-1/2-12 UNF-2A, 242-1/2-12 UNF-2A, 244-1/2-12 UNF-2A, 246-1/2-12 UNF-2A, 248-1/2-12 UNF-2A, 250-1/2-12 UNF-2A, 252-1/2-12 UNF-2A, 254-1/2-12 UNF-2A, 256-1/2-12 UNF-2A, 258-1/2-12 UNF-2A, 260-1/2-12 UNF-2A, 262-1/2-12 UNF-2A, 264-1/2-12 UNF-2A, 266-1/2-12 UNF-2A, 268-1/2-12 UNF-2A, 270-1/2-12 UNF-2A, 272-1/2-12 UNF-2A, 274-1/2-12 UNF-2A, 276-1/2-12 UNF-2A, 278-1/2-12 UNF-2A, 280-1/2-12 UNF-2A, 282-1/2-12 UNF-2A, 284-1/2-12 UNF-2A, 286-1/2-12 UNF-2A, 288-1/2-12 UNF-2A, 290-1/2-12 UNF-2A, 292-1/2-12 UNF-2A, 294-1/2-12 UNF-2A, 296-1/2-12 UNF-2A, 298-1/2-12 UNF-2A, 300-1/2-12 UNF-2A, 302-1/2-12 UNF-2A, 304-1/2-12 UNF-2A, 306-1/2-12 UNF-2A, 308-1/2-12 UNF-2A, 310-1/2-12 UNF-2A, 312-1/2-12 UNF-2A, 314-1/2-12 UNF-2A, 316-1/2-12 UNF-2A, 318-1/2-12 UNF-2A, 320-1/2-12 UNF-2A, 322-1/2-12 UNF-2A, 324-1/2-12 UNF-2A, 326-1/2-12 UNF-2A, 328-1/2-12 UNF-2A, 330-1/2-12 UNF-2A, 332-1/2-12 UNF-2A, 334-1/2-12 UNF-2A, 336-1/2-12 UNF-2A, 338-1/2-12 UNF-2A, 340-1/2-12 UNF-2A, 342-1/2-12 UNF-2A, 344-1/2-12 UNF-2A, 346-1/2-12 UNF-2A, 348-1/2-12 UNF-2A, 350-1/2-12 UNF-2A, 352-1/2-12 UNF-2A, 354-1/2-12 UNF-2A, 356-1/2-12 UNF-2A, 358-1/2-12 UNF-2A, 360-1/2-12 UNF-2A, 362-1/2-12 UNF-2A, 364-1/2-12 UNF-2A, 366-1/2-12 UNF-2A, 368-1/2-12 UNF-2A, 370-1/2-12 UNF-2A, 372-1/2-12 UNF-2A, 374-1/2-12 UNF-2A, 376-1/2-12 UNF-2A, 378-1/2-12 UNF-2A, 380-1/2-12 UNF-2A, 382-1/2-12 UNF-2A, 384-1/2-12 UNF-2A, 386-1/2-12 UNF-2A, 388-1/2-12 UNF-2A, 390-1/2-12 UNF-2A, 392-1/2-12 UNF-2A, 394-1/2-12 UNF-2A, 396-1/2-12 UNF-2A, 398-1/2-12 UNF-2A, 400-1/2-12 UNF-2A, 402-1/2-12 UNF-2A, 404-1/2-12 UNF-2A, 406-1/2-12 UNF-2A, 408-1/2-12 UNF-2A, 410-1/2-12 UNF-2A, 412-1/2-12 UNF-2A, 414-1/2-12 UNF-2A, 416-1/2-12 UNF-2A, 418-1/2-12 UNF-2A, 420-1/2-12 UNF-2A, 422-1/2-12 UNF-2A, 424-1/2-12 UNF-2A, 426-1/2-12 UNF-2A, 428-1/2-12 UNF-2A, 430-1/2-12 UNF-2A, 432-1/2-12 UNF-2A, 434-1/2-12 UNF-2A, 436-1/2-12 UNF-2A, 438-1/2-12 UNF-2A, 440-1/2-12 UNF-2A, 442-1/2-12 UNF-2A, 444-1/2-12 UNF-2A, 446-1/2-12 UNF-2A, 448-1/2-12 UNF-2A, 450-1/2-12 UNF-2A, 452-1/2-12 UNF-2A, 454-1/2-12 UNF-2A, 456-1/2-12 UNF-2A, 458-1/2-12 UNF-2A, 460-1/2-12 UNF-2A, 462-1/2-12 UNF-2A, 464-1/2-12 UNF-2A, 466-1/2-12 UNF-2A, 468-1/2-12 UNF-2A, 470-1/2-12 UNF-2A, 472-1/2-12 UNF-2A, 474-1/2-12 UNF-2A, 476-1/2-12 UNF-2A, 478-1/2-12 UNF-2A, 480-1/2-12 UNF-2A, 482-1/2-12 UNF-2A, 484-1/2-12 UNF-2A, 486-1/2-12 UNF-2A, 488-1/2-12 UNF-2A, 490-1/2-12 UNF-2A, 492-1/2-12 UNF-2A, 494-1/2-12 UNF-2A, 496-1/2-12 UNF-2A, 498-1/2-12 UNF-2A, 500-1/2-12 UNF-2A, 502-1/2-12 UNF-2A, 504-1/2-12 UNF-2A, 506-1/2-12 UNF-2A, 508-1/2-12 UNF-2A, 510-1/2-12 UNF-2A, 512-1/2-12 UNF-2A, 514-1/2-12 UNF-2A, 516-1/2-12 UNF-2A, 518-1/2-12 UNF-2A, 520-1/2-12 UNF-2A, 522-1/2-12 UNF-2A, 524-1/2-12 UNF-2A, 526-1/2-12 UNF-2A, 528-1/2-12 UNF-2A, 530-1/2-12 UNF-2A, 532-1/2-12 UNF-2A, 534-1/2-12 UNF-2A, 536-1/2-12 UNF-2A, 538-1/2-12 UNF-2A, 540-1/2-12 UNF-2A, 542-1/2-12 UNF-2A, 544-1/2-12 UNF-2A, 546-1/2-12 UNF-2A, 548-1/2-12 UNF-2A, 550-1/2-12 UNF-2A, 552-1/2-12 UNF-2A, 554-1/2-12 UNF-2A, 556-1/2-12 UNF-2A, 558-1/2-12 UNF-2A, 560-1/2-12 UNF-2A, 562-1/2-12 UNF-2A, 564-1/2-12 UNF-2A, 566-1/2-12 UNF-2A, 568-1/2-12 UNF-2A, 570-1/2-12 UNF-2A, 572-1/2-12 UNF-2A, 574-1/2-12 UNF-2A, 576-1/2-12 UNF-2A, 578-1/2-12 UNF-2A, 580-1/2-12 UNF-2A, 582-1/2-12 UNF-2A, 584-1/2-12 UNF-2A, 586-1/2-12 UNF-2A, 588-1/2-12 UNF-2A, 590-1/2-12 UNF-2A, 592-1/2-12 UNF-2A, 594-1/2-12 UNF-2A, 596-1/2-12 UNF-2A, 598-1/2-12 UNF-2A, 600-1/2-12 UNF-2A, 602-1/2-12 UNF-2A, 604-1/2-12 UNF-2A, 606-1/2-12 UNF-2A, 608-1/2-12 UNF-2A, 610-1/2-12 UNF-2A, 612-1/2-12 UNF-2A, 614-1/2-12 UNF-2A, 616-1/2-12 UNF-2A, 618-1/2-12 UNF-2A, 620-1/2-12 UNF-2A, 622-1/2-12 UNF-2A, 624-1/2-12 UNF-2A, 626-1/2-12 UNF-2A, 628-1/2-12 UNF-2A, 630-1/2-12 UNF-2A, 632-1/2-12 UNF-2A, 634-1/2-12 UNF-2A, 636-1/2-12 UNF-2A, 638-1/2-12 UNF-2A, 640-1/2-12 UNF-2A, 642-1/2-12 UNF-2A, 644-1/2-12 UNF-2A, 646-1/2-12 UNF-2A, 648-1/2-12 UNF-2A, 650-1/2-12 UNF-2A, 652-1/2-12 UNF-2A, 654-1/2-12 UNF-2A, 656-1/2-12 UNF-2A, 658-1/2-12 UNF-2A, 660-1/2-12 UNF-2A, 662-1/2-12 UNF-2A, 664-1/2-12 UNF-2A, 666-1/2-12 UNF-2A, 668-1/2-12 UNF-2A, 670-1/2-12 UNF-2A, 672-1/2-12 UNF-2A, 674-1/2-12 UNF-2A, 676-1/2-12 UNF-2A, 678-1/2-12 UNF-2A, 680-1/2-12 UNF-2A, 682-1/2-12 UNF-2A, 684-1/2-12 UNF-2A, 686-1/2-12 UNF-2A, 688-1/2-12 UNF-2A, 690-1/2-12 UNF-2A, 692-1/2-12 UNF-2A, 694-1/2-12 UNF-2A, 696-1/2-12 UNF-2A, 698-1/2-12 UNF-2A, 700-1/2-12 UNF-2A, 702-1/2-12 UNF-2A, 704-1/2-12 UNF-2A, 706-1/2-12 UNF-2A, 708-1/2-12 UNF-2A, 710-1/2-12 UNF-2A, 712-1/2-12 UNF-2A, 714-1/2-12 UNF-2A, 716-1/2-12 UNF-2A, 718-1/2-12 UNF-2A, 720-1/2-12 UNF-2A, 722-1/2-12 UNF-2A, 724-1/2-12 UNF-2A, 726-1/2-12 UNF-2A, 728-1/2-12 UNF-2A, 730-1/2-12 UNF-2A, 732-1/2-12 UNF-2A, 734-1/2-12 UNF-2A, 736-1/2-12 UNF-2A, 738-1/2-12 UNF-2A, 740-1/2-12 UNF-2A, 742-1/2-12 UNF-2A, 744-1/2-12 UNF-2A, 746-1/2-12 UNF-2A, 748-1/2-12 UNF-2A, 750-1/2-12 UNF-2A, 752-1/2-12 UNF-2A, 754-1/2-12 UNF-2A, 756-1/2-12 UNF-2A, 758-1/2-12 UNF-2A, 760-1/2-12 UNF-2A, 762-1/2-12 UNF-2A, 764-1/2-12 UNF-2A, 766-1/2-12 UNF-2A, 768-1/2-12 UNF-2A, 770-1/2-12 UNF-2A, 772-1/2-12 UNF-2A, 774-1/2-12 UNF-2A, 776-1/2-12 UNF-2A, 778-1/2-12 UNF-2A, 780-1/2-12 UNF-2A, 782-1/2-12 UNF-2A, 784-1/2-12 UNF-2A, 786-1/2-12 UNF-2A, 788-1/2-12 UNF-2A, 790-1/2-12 UNF-2A, 792-1/2-12 UNF-2A, 794-1/2-12 UNF-2A, 796-1/2-12 UNF-2A, 798-1/2-12 UNF-2A, 800-1/2-12 UNF-2A, 802-1/2-12 UNF-2A, 804-1/2-12 UNF-2A, 806-1/2-12 UNF-2A, 808-1/2-12 UNF-2A, 810-1/2-12 UNF-2A, 812-1/2-12 UNF-2A, 814-1/2-12 UNF-2A, 816-1/2-12 UNF-2A, 818-1/2-12 UNF-2A, 820-1/2-12 UNF-2A, 822-1/2-12 UNF-2A, 824-1/2-12 UNF-2A, 826-1/2-12 UNF-2A, 828-1/2-12 UNF-2A, 830-1/2-12 UNF-2A, 832-1/2-12 UNF-2A, 834-1/2-12 UNF-2A, 836-1/2-12 UNF-2A, 838-1/2-12 UNF-2A, 840-1/2-12 UNF-2A, 842-1/2-12 UNF-2A, 844-1/2-12 UNF-2A, 846-1/2-12 UNF-2A, 848-1/2-12 UNF-2A, 850-1/2-12 UNF-2A, 852-1/2-12 UNF-2A, 854-1/2-12 UNF-2A, 856-1/2-12 UNF-2A, 858-1/2-12 UNF-2A, 860-1/2-12 UNF-2A, 862-1/2-12 UNF-2A, 864-1/2-12 UNF-2A, 866-1/2-12 UNF-2A, 868-1/2-12 UNF-2A, 870-1/2-12 UNF-2A, 872-1/2-12 UNF-2A, 874-1/2-12 UNF-2A, 876-1/2-12 UNF-2A, 878-1/2-12 UNF-2A, 880-1/2-12 UNF-2A, 882-1/2-12 UNF-2A, 884-1/2-12 UNF-2A, 886-1/2-12 UNF-2A, 888-1/2-12 UNF-2A, 890-1/2-12 UNF-2A, 892-1/2-12 UNF-2A, 894-1/2-12 UNF-2A, 896-1/2-12 UNF-2A, 898-1/2-12 UNF-2A, 900-1/2-12 UNF-2A, 902-1/2-12 UNF-2A, 904-1/2-12 UNF-2A, 906-1/2-12 UNF-2A, 908-1/2-12 UNF-2A, 910-1/2-12 UNF-2A, 912-1/2-12 UNF-2A, 914-1/2-12 UNF-2A, 916-1/2-12 UNF-2A, 918-1/2-12 UNF-2A, 920-1/2-12 UNF-2A, 922-1/2-12 UNF-2A, 924-1/2-12 UNF-2A, 926-1/2-12 UNF-2A, 928-1/2-12 UNF-2A, 930-1/2-12 UNF-2A, 932-1/2-12 UNF-2A, 934-1/2-12 UNF-2A, 936-1/2-12 UNF-2A, 938-1/2-12 UNF-2A, 940-1/2-12 UNF-2A, 942-1/2-12 UNF-2A, 944-1/2-12 UNF-2A, 946-1/2-12 UNF-2A, 948-1/2-12 UNF-2A, 950-1/2-12 UNF-2A, 952-1/2-12 UNF-2A, 954-1/2-12 UNF-2A, 956-1/2-12 UNF-2A, 958-1/2-12 UNF-2A, 960-1/2-12 UNF-2A, 962-1/2-12 UNF-2A, 964-1/2-12 UNF-2A, 966-1/2-12 UNF-2A, 968-1/2-12 UNF-2A, 970-1/2-12 UNF-2A, 972-1/2-12 UNF-2A, 974-1/2-12 UNF-2A, 976-1/2-12 UNF-2A, 978-1/2-12 UNF-2A, 980-1/2-12 UNF-2A, 982-1/2-12 UNF-2A, 984-1/2-12 UNF-2A, 986-1/2-12 UNF-2A, 988-1/2-12 UNF-2A, 990-1/2-12 UNF-2A, 992-1/2-12 UNF-2A, 994-1/2-12 UNF-2A, 996-1/2-12 UNF-2A, 998-1/2-12 UNF-2A, 1000-1/2-12 UNF-2A

SHIFT SAFETY INTERLOCK SCHEMATIC MID-SHIP GEAR CASE

The safety interlock prevents the main pump shift from actuating while the automatic truck transmission is in drive gear. This eliminates clashing and possible damage of the pump gear set.

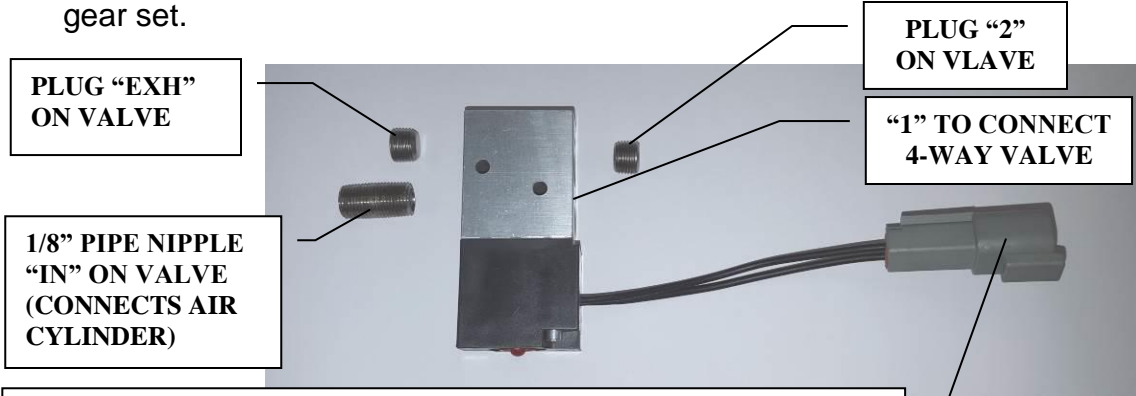

-DEUTSCH 2-WAY RECEPTACLE DT04-2P.
-SUPPLY VOLTAGE AND GROUND TO CLOSE VALVE WHEN MAIN CHASSIS TRANSMISSION IS IN PUMP GEAR (POLARITY IS NOT IMPORTANT)
-THIS WILL PREVENT THE PUMP FROM SHIFTING WHEN THE MAIN CHASSIS TRANSMISSION IS IN PUMP GEAR

Assembly Notes:

- 1) Use Loctite 565 PST or equivalent pipe sealant on tapered pipe joints. (DO NOT USE TEFLON TAPE)
- 2) DO NOT over tighten fittings, doing so may damage thread.

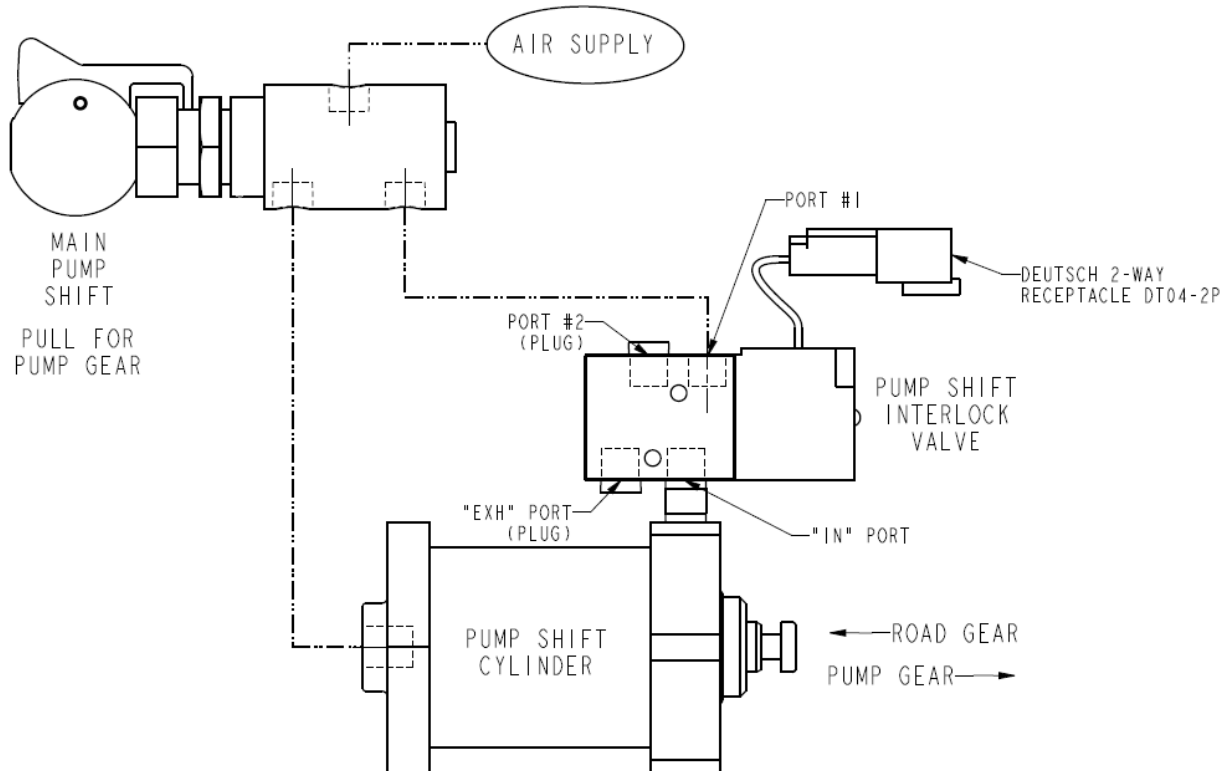

Prepared by: TED
 Approved by: DJF

Date: Dec 07, 2015
 Revision Date: Dec 07, 2015 - TED

Rev. #: 0
 Page: 1 of 1

1205562.doc

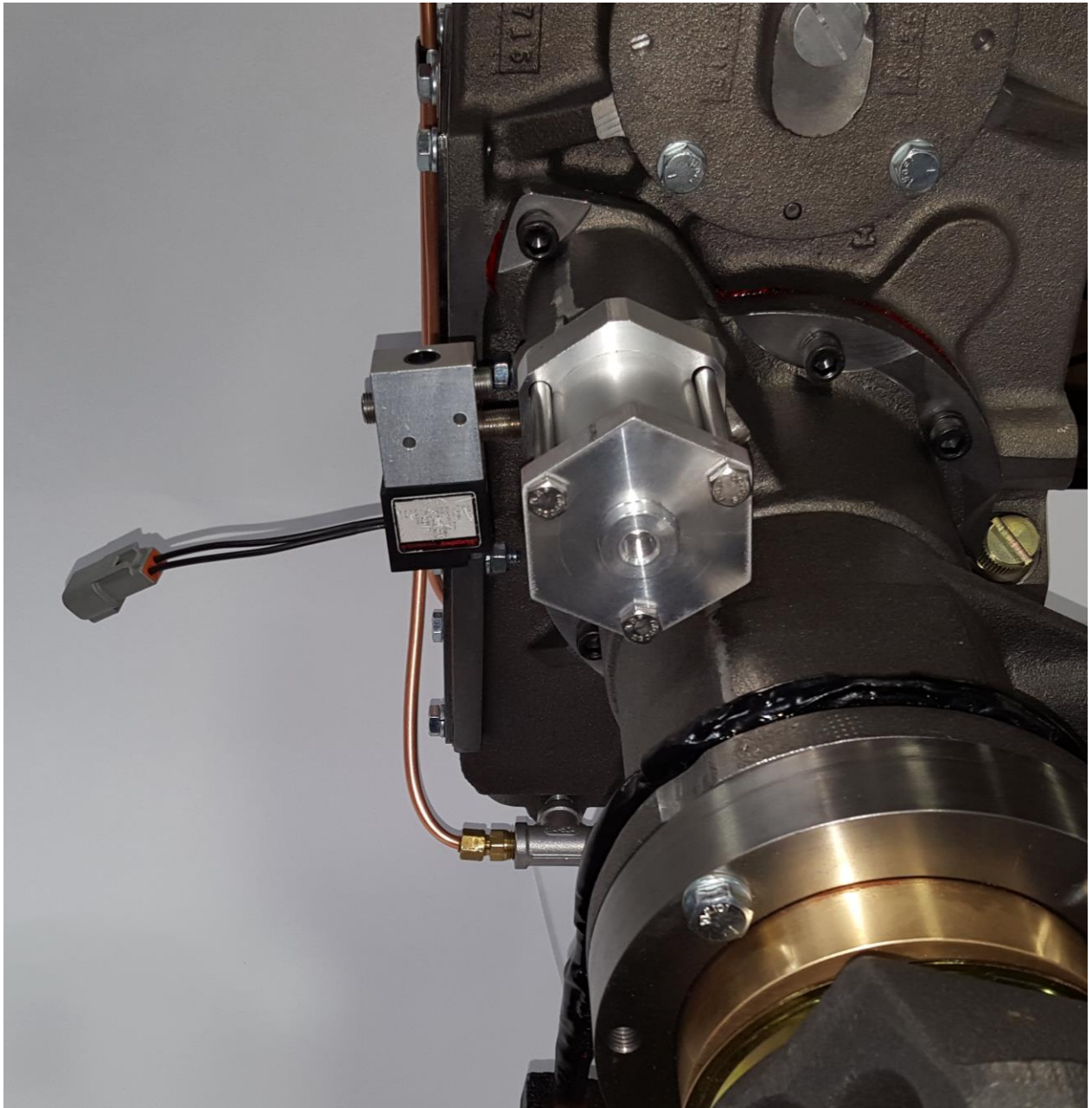

REVISIONS

LTR	DESCRIPTION	DATE	CHG NO.	APPR'D

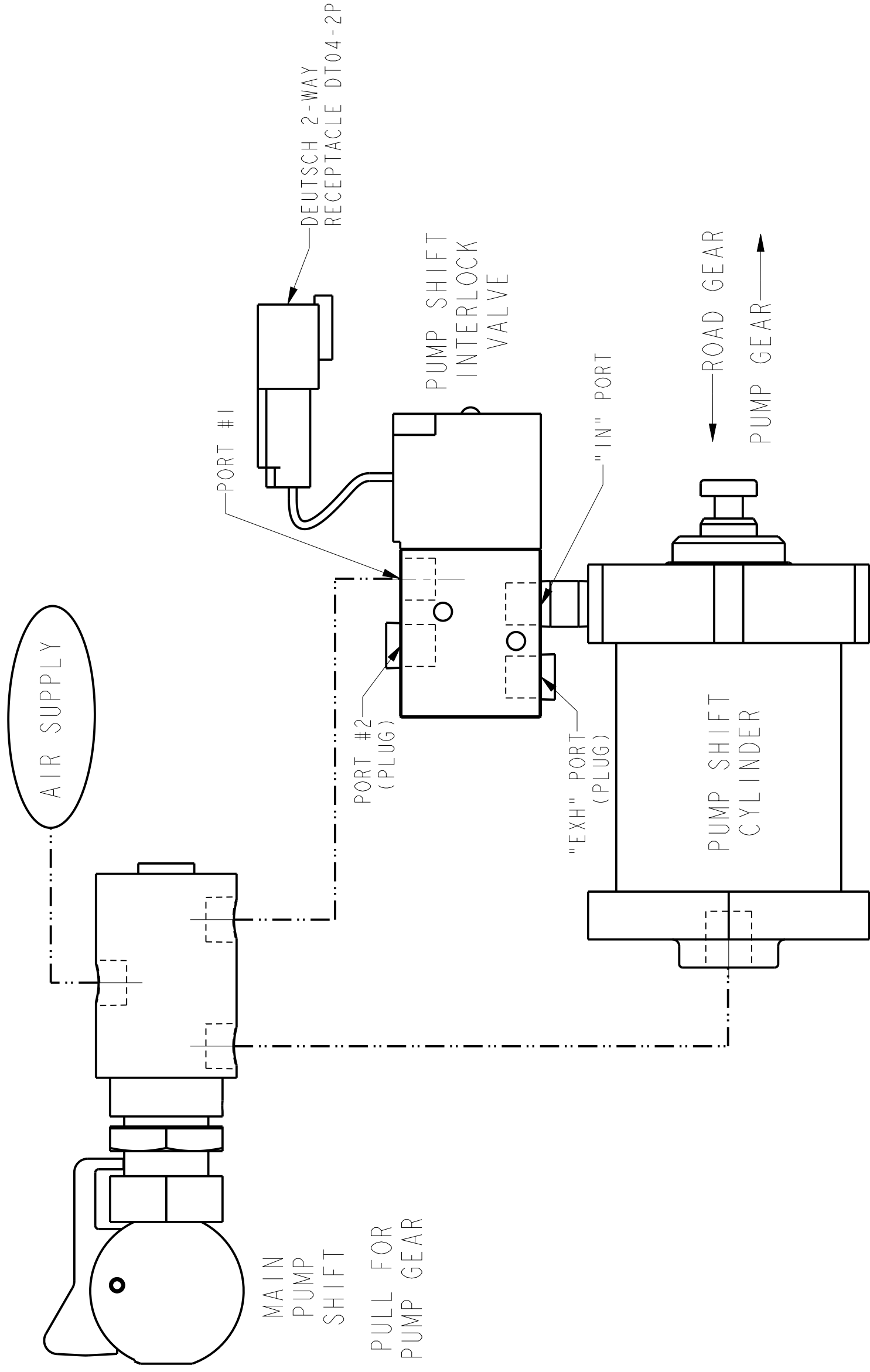

THIRD ANGLE PROJECTION
INCH [MILLIMETER]

REMOVE SHARP EDGES

MATERIAL DESCRIPTION:

THIS DESIGN IS THE PROPERTY OF
W.S. DARLEY AND CO. - UNAUTHORIZED
REPRODUCTION IS PROHIBITED

OLD PART NO.	PATTERN NO.

TOLERANCE EXCEPT AS NOTED	DR'N TED
.00 ±.03	CHKD WAH
.000 ±.010	TRCD
ANGLES ±1°	

MODEL	MDL CREATED	SHEET
1205562		1/1
W.S. Darley & Co. ITASCA, IL - CHIPPEWA FALLS, WI		
INSTR - SHIFT SAFETY INTERLOCK PUMP SHIFT IN DRIVE		
DATE	SCALE	
08-Dec-15	1/1	
1205562		