

# Operator's Manual Table of Contents For Darley Engine Driven HE Fire Pump

		<u>Page #</u>
Description, Operation & Maintenance, Lubrication-----	1200519	1
Related Drawings-----	DHD0103	2
	DHC0600	3
	DHC0601	4
Mechanical Seal -----	1200583	5-6
Seal Installation Instructions -----	1201040	7-8
Packing Adjustment-----	1200504	9-10
	1200514	11
High Pressure Stage-----	1200511	12
	DLC0104	13
General Operation-----	1200509	14-18
	1200510	19-20
	1201500-1201502	21-31
Electric Primer -----	1200512	32-33
	DVC0207	34
	DVC0209	35
Multiple Drain Valve -----	1204506	36
	DGC0903	37
Ball Valve-----	1200000	38
	DGC0100	39
Relief Valve "Suction / Discharge Valve"-----	1200508	40-41
	DGC0115	42
	1200503	43-44
	DGC0141	45-46
	DGD0800	47
Butterfly Valve -----	1201002	48
	DGD0104	49
Pump Overheat Protection -----	DGD0101	50
	DGM0117	51
	5209401	52-53
	5209402	54-56

**IF FURTHER INFORMATION IS NEEDED, CALL W.S. DARLEY & CO. AT  
CHIPPEWA FALLS, WI. AT 800-634-7812 or 715-726-2650**

## **This manual is for DARLEY FIRE PUMP:**

Model: HE Pump Serial Number: \_\_\_\_\_

### **Description of Pump Type**

The **Type HE** pump is a high speed, single stage, centrifugal pump.

The pump is mounted to the engine SAE housing and directly driven by a flywheel drive plate.

### **OPERATION AND MAINTENANCE OF TYPE HE FIRE PUMP**

Right and left, and front and rear locations are referred to from a position facing the pump suction inlet.

#### **Lubrication**

Keep the gear case filled with oil to the level of the oil level plug, which is marked on the pump gear case.

Check the oil level every 25 hours or every 3 month, and change it every 50 hours or 6 months.

Use 80W/90 gear lube oil - not grease - in the pump transmission.

**CAUTION: Do not overfill.**

#### **Operation of Pump**

The pump is directly coupled to the engine through a step up gear box. Prepare the pump for operation before starting the engine. Prime the pump system, then start the engine.

**Never run the pump dry except momentarily and at low speeds.**

Never start the engine with a wide open throttle.

Never run the pump at high speed at any time unless it is discharging water.

**WARNING: Do not use this pump for hose testing.**



**Pump Division  
1051 Palmer St.  
Chippewa Falls, WI 54729  
715-726-2650**

## **Technical Bulletin on Diesel-driven Engine-mounted Pumps**

1202516

May 9, 2015

Pumps mounted to diesel engines should not be run at a low idle for extended periods. This can cause damage to the engine through incomplete fuel burn at low temperatures, a process known as wet-stacking. Additionally, operation at low idle generally results in rougher engine operation, which can cause damage to the pump due to the uneven vibrations. Such damage can occur to drive disks, shafts, impeller nuts and other components, and ensuing damage may then result.

Most diesel engine manufacturers recommend that the engine should be operated no lower than 1000 to 1200 RPM if being idled for more than a few minutes. Operation at low idle during start-up should not cause damage.

Any questions regarding proper engine operation should be directed to the engine manufacturer. Darley recommends a minimum idle speed of 1200 RPM for our pumps.

Questions can also be directed to our Customer Service Department at 800-634-7812 or 715-726-2650.

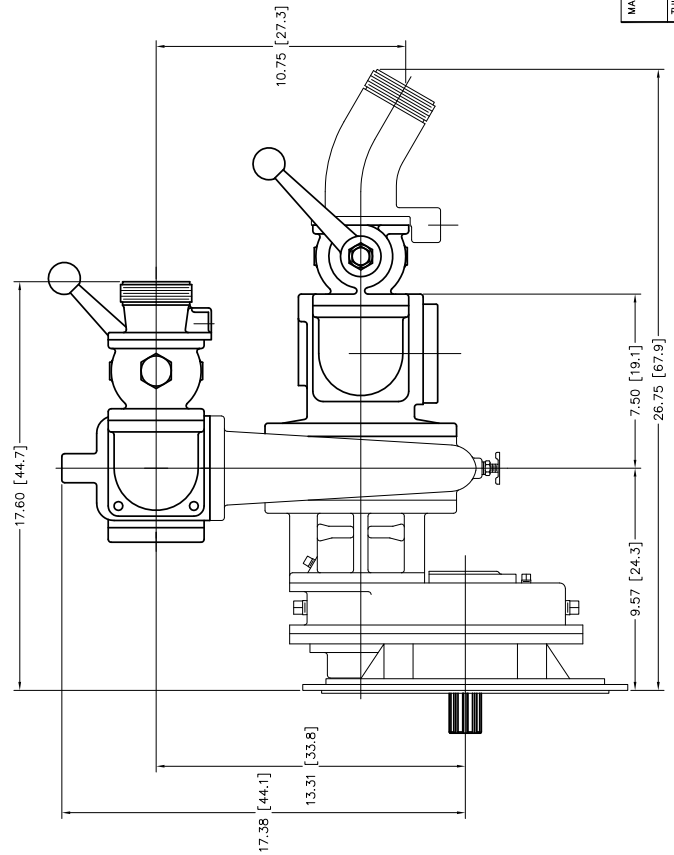
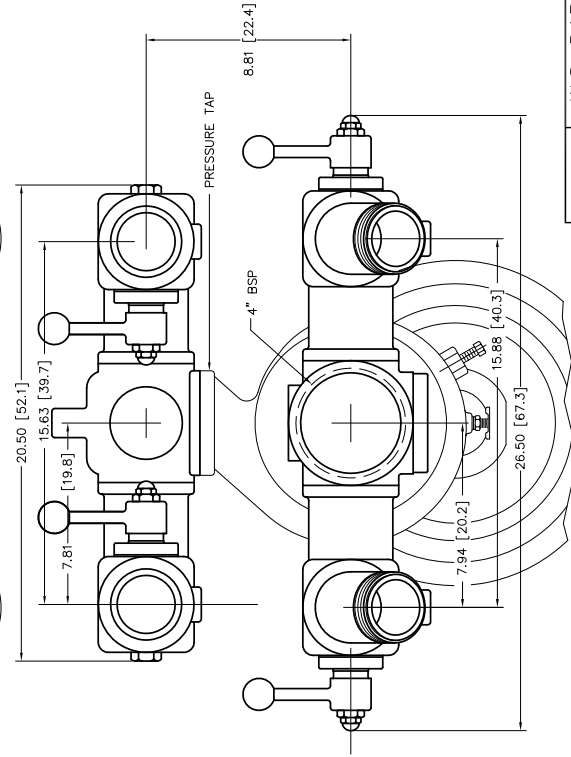
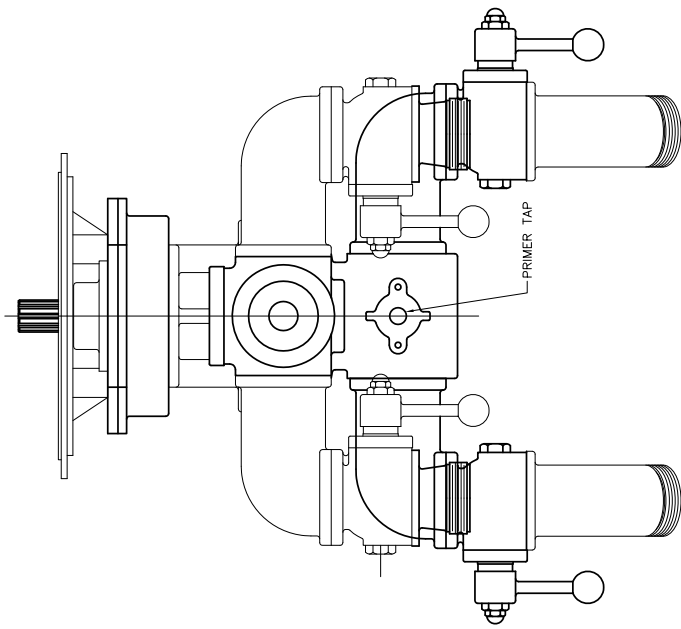

		<b>W.S. DARLEY &amp; CO.</b> MELROSE PARK, IL - CHIPPewa FALLS, WI	
<b>DWG - HES00 DIMENSIONAL</b> <b>SAE #5</b>		<b>DATE APR15.94</b> <b>SCALE 1/4</b>	
<b>DESIGNER</b> S. LEE	<b>CHKD.</b> (blank)	<b>DATE</b> APR15.94	<b>SCALE</b> 1/4
<b>PATTERN NO.</b> H448-3	<b>DO NOT SCALE PRINT</b>	<b>ALL DIMENSIONS IN INCHES UNLESS NOTED</b>	<b>REPRODUCTION IS PROHIBITED</b>
<b>MATERIAL:</b>	<b>THIS DESIGN IS THE PROPERTY OF W.S. DARLEY AND CO. UNAUTHORIZED REPRODUCTION IS PROHIBITED.</b>	<b>DO NOT SCALE PRINT</b>	<b>REPRODUCTION IS PROHIBITED</b>

REP #	NAME OF PART	QTY
1	OIL SEAL	1
2	INBOARD HEAD	1
3	ENGINE ADAPTER	1
4	WATER SLINGER	1
6	DRIVE FLANGE	1
7	OIL FILL PLUG-3/8 NPT	1
8	OIL DRAIN PLUG-3/8 NPT - MAGNETIC	1
12	PACKING PLUNGER	1
14	VENT PLUG-1/8 NPT	1
16	OIL SEAL - PUMP SHAFT	1
18	VOLUTE	1
19	PUMP CASING GASKET	2
21	IMPELLER	1
22A	SEAL RING OUTBOARD	1
22B	SEAL RING INBOARD	1
24	IMPELLER SHAFT	1
25	IMPELLER NUT	1
26	COTTER KEY	1
27	IMPELLER WASHER	1
28	WASHER	1
29	DISCHARGE FLANGE	1
30	GASKET-DISCHARGE FLANGE	1
33	BEARING	1
35	BEARING CAP	1
36	BEARING	2
37	BEARING CAP GASKET	2
38	SPACER BUSHING	1
40	GEAR CASE	1
41	GEAR CASE GASKET	1
42	GEAR CASE COVER	1
43	DRIVE GEAR	1
44	DRAIN COCK-1/4 NPT	1
45	GEAR KEY	1
49	DRIVE SHAFT	1
50	PINION KEY	1
52	BEARING	1
53	BEARING LOCKWASHER	1
54	BEARING LOCKNUT	1
55	BEARING CAP	1
57	DRIVEN PINION	1
73	OUTBOARD HEAD	1
82	SPACER BUSHING	1
84	GLAND NUT	1
85	PACKING PLUNGER STUD	1
86	PACKING PLUNGER GUIDE	1
87	STUFFING BOX	1
90	PACKING	1

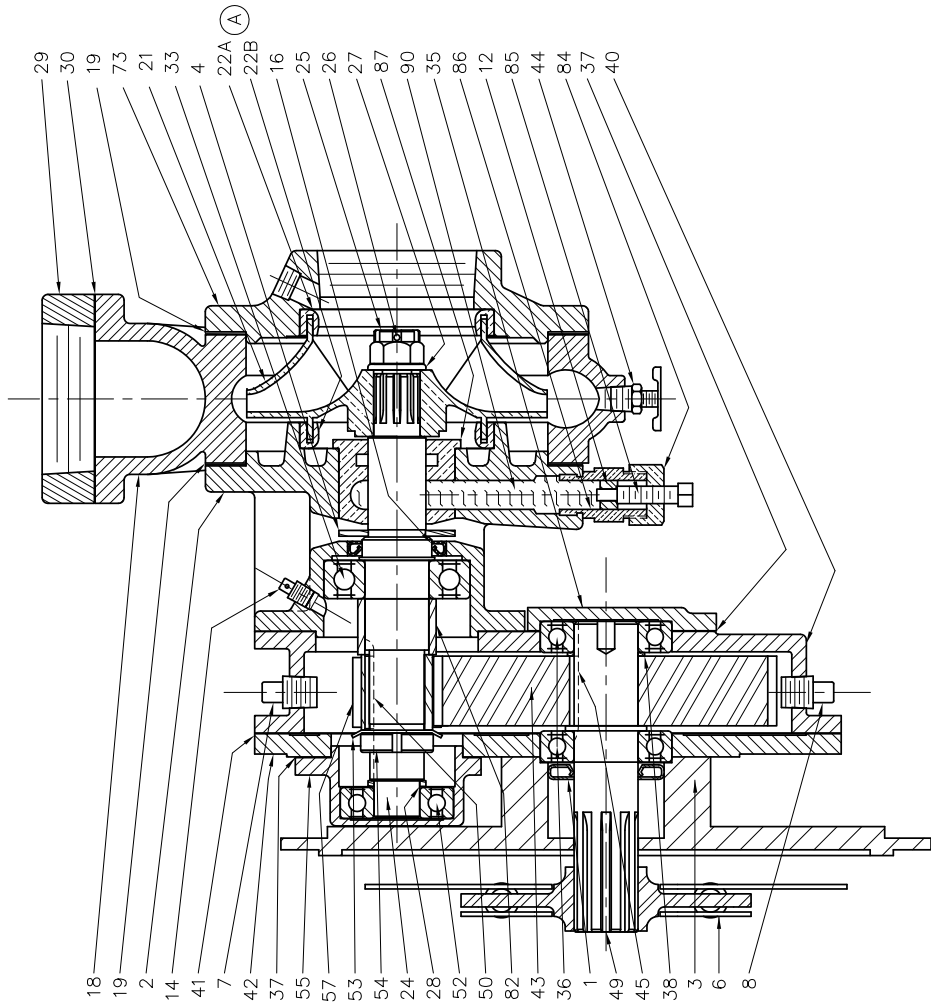

REV	DESCRIPTION	DATE	ENG. NO.	APPROV
1	CHANGED REF. NO. FROM 22 TO 22A AND 22B TO 22B TO DIFFERENTIATE BETWEEN SEAL RINGS IF NECESSARY	17MAY2002	2002-84	DMG

**W.S. DARLEY & CO.**  
 MELROSE PARK, IL. - GRIFFITH, ILL., IN.  
 DWG - HES00 CROSS SECTION  
 PACKING

OLD PART NO. H450-2	DATE JAN24,94	SCALE 1/2
THIS DESIGN IS THE PROPERTY OF W.S. DARLEY & CO. UNAUTHORIZED REPRODUCTION IS PROHIBITED.	DO NOT SCALE PRINT	
ALL DIMENSIONS IN INCHES UNLESS NOTED		
REP'D	TED/RJC	CHKD
RCB01101950CKE		

REP#	NAME OF PART	QTY
2	INBOARD HEAD	1
3	ENGINE ADAPTER	1
4	WATER SLINGER	1
5	CABLE DRIVE NUT	1
6	DRIVE FLANGE	1
7	OIL FILL PLUG-3/8 NPT	1
8	OIL DRAIN PLUG-3/8 NPT - MAGNETIC	1
14	VENT PLUG-1/8 NPT	1
16	OIL SEAL - PUMP SHAFT	1
18	VOLUTE	1
19	PUMP CASING GASKET	2
21	IMPELLER	2
22	SEAL RING	2
24	IMPELLER SHAFT	1
25	IMPELLER NUT	1
26	COTTER KEY - S.S.	1
27	IMPELLER WASHER	1
28	BEARING BACKUP WASHER	1
29	DISCHARGE (REF)	1
30	GASKET-DISCHARGE (REF)	1
33	BEARING	1
35	BEARING CAP	1
36	BEARING	2
37	BEARING CAP GASKET	2
38	SPACER BUSHING	1
40	GEAR CASE	1
41	GEAR CASE GASKET	1
42	GEAR CASE COVER	1
43	DRIVE GEAR	1
44	DRAIN COCK-1/4 NPT	1
45	GEAR KEY	1
46	OIL SEAL-TACH	1
48	OIL SEAL	1
49	DRIVE SHAFT	1
50	PINION KEY	1
52	BEARING	1
53	BEARING LOCKWASHER	1
54	BEARING LOCKNUT	1
55	BEARING CAP	1
57	PINION GEAR	1
73	OUTBOARD HEAD	1
82	SPACER BUSHING	1
86	PLASTIC PLUG - PACKING GLAND OPENING	1
87	STUFFING BOX	1
90	MECHANICAL SEAL	1
91	PLASTIC DUST PLUG - TACH.	1
92	O'RING - SUCTION HEAD	1

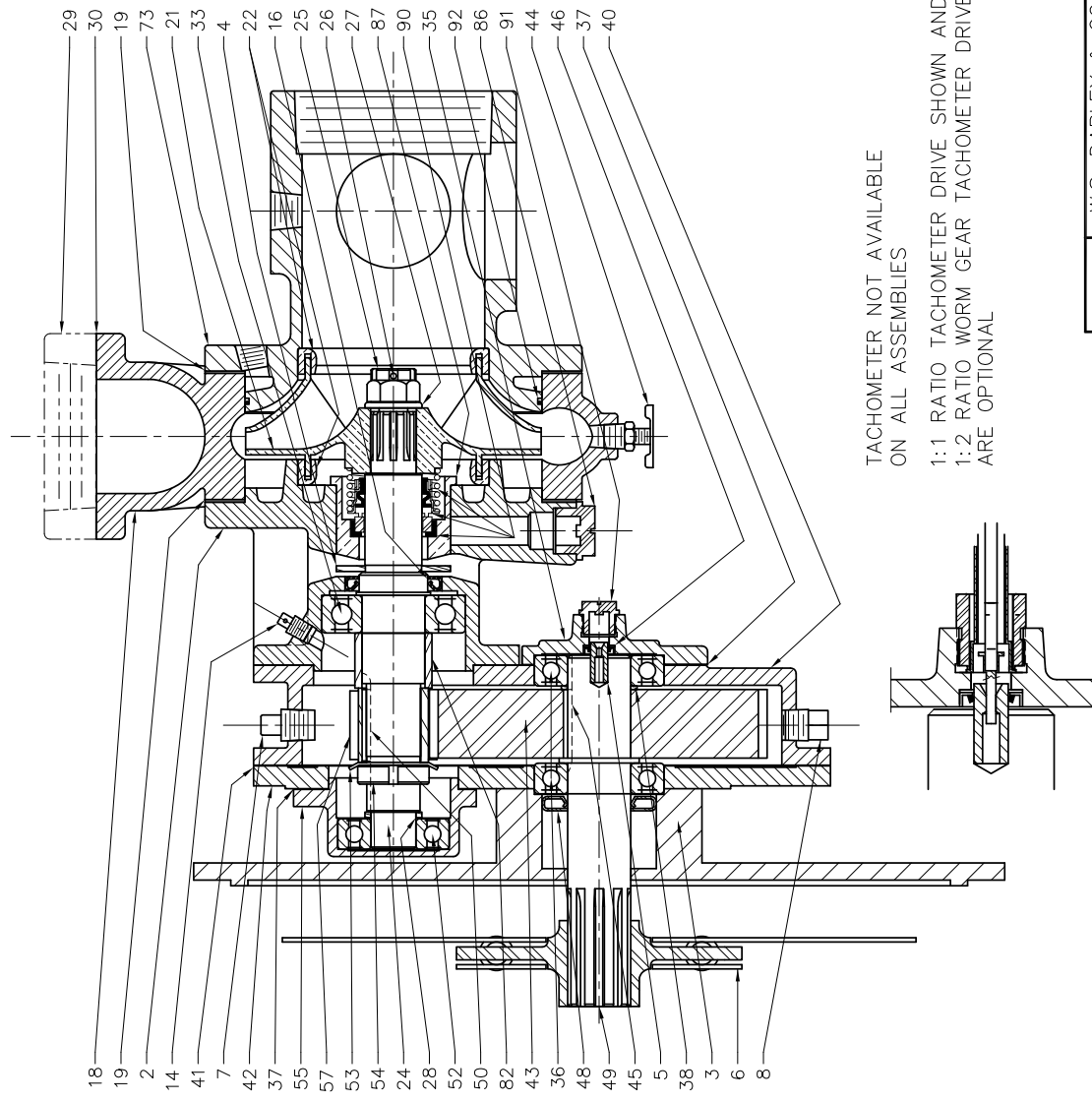

TACHOMETER NOT AVAILABLE  
ON ALL ASSEMBLIES

1:1 RATIO TACHOMETER DRIVE SHOWN AND  
1:2 RATIO WORM GEAR TACHOMETER DRIVE  
ARE OPTIONAL

TACHOMETER DRIVE DETAIL

W.S. DARLEY & CO. MELROSE PARK, IL. - GRIFFIN FALLS, WI. DWG - HE500 CROSS SECTION MECHANICAL SEAL	
DRN TED CHKD TRCD	DATE FEB 7, 94 SCALE 1/2

OLD PART NO. H452	DO NOT SCALE PRINT
THIS DESIGN IS THE PROPERTY OF W.S. DARLEY & CO. UNLESS OTHERWISE AUTHORIZED REPRODUCTION IS PROHIBITED	
ALL DIMENSIONS IN INCHES UNLESS NOTED	

## **Mechanical Shaft Seal**

This pump assembly incorporates high quality mechanical shaft seal(s) separating the pump housing components from atmosphere. Depending on the pump design, there may be one or two seals on each impeller shaft.

The seal size, design type, component materials, and housing configuration have been specifically designed for this pump application and rated operating parameters.

## **Mechanical Seal Basics**

A mechanical seal is a device that houses two highly polished components (known as faces). One face rotates, the other is stationary. A secondary elastomer bellows seals the primary ring to the shaft. An o-ring or cup seal seals the mating ring in the housing. The polished seal faces of the primary and mating rings are pressed together by a spring mechanism to provide adequate force to affect a seal. The force acting between the seal faces increases in direct proportion to product pressure.

The elastomer bellows seal utilized in this pump has the following design features:

- Mechanical drive of the primary seal ring. The drive band's notch design eliminates overstressing the elastomer sealing bellows.
- Bellows design provides automatic compensation for shaft endplay, run out, and primary ring wear.
- Seal face contact pressure is controlled by a single, non-clogging coil spring. This coil spring has been custom welded per Darley specifications to eliminate high-speed spring distortion.

The seal housing is designed and ported to provide optimal water flow and pressure assuring proper cooling and flushing of the seal components.

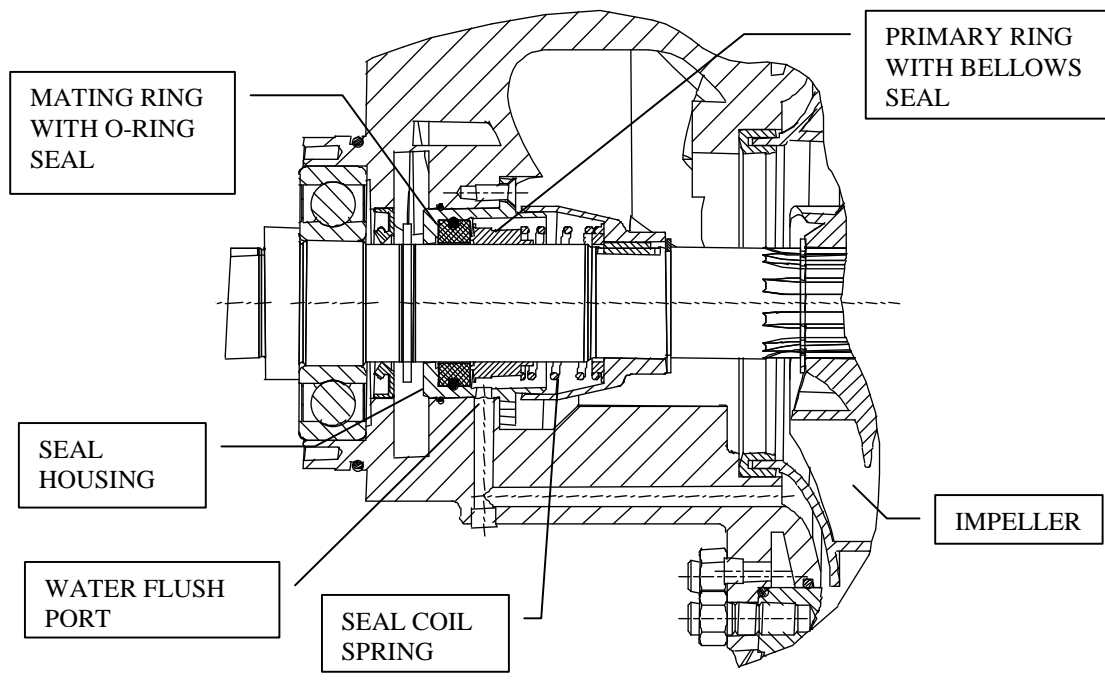

## **Operation and Maintenance**

When operated within rated operating conditions of this pump, these seals will provide trouble free service for extended periods.

Properly selected and applied mechanical shaft seals are leak free and require no adjustment. Should the seal area develop a leak, investigate the cause as soon as possible. Seal failure, leakage, may be the result of; worn seal faces, leaking bellows, or damaged o-rings. These failures may be attributed to bearing failure, impeller blockage, impeller imbalance, seal housing contamination, operating beyond pump design rating, or dry running,

Mechanical shaft seal design relies on the sealed media, in this case, water, to cool and lubricate the sealing surfaces. Therefore, extended dry operation may cause overheating and scoring or damage to the sealing surfaces, resulting in excessive leakage or a much shortened seal life.

To maximize seal life, minimize operation at pump pressures higher than pump rating. While operating at pressures beyond rating will not immediately damage the seal, it will increase sealing surface wear rate.



**CAUTION:** DO NOT RUN THE PUMP DRY EXCEPT MOMENTARILY AND AT LOW SPEEDS



**CAUTION:** DO NOT USE THIS PUMP FOR HOSE TESTING



**CAUTION:** THE MECHANICAL SEAL SHOULD NOT BE RUN DRY, WHILE THE PUMP IS NOT ENTRAINED WITH WATER, FOR A PERIOD LONGER THAN 2 MINUTES. FAILURE TO FOLLOW THIS RECOMMENDATION WILL LEAD TO PREMATURE WEAR AND FAILURE OF YOUR MECHANICAL SHAFT SEAL.





# DARLEY

## INSTALLATION OF MECHANICAL FACE SEAL WITH O’RING

### SPECIAL HANDLING

Study the engineering layout before installing the seal. This shaft seal is a precision product and should be handled and treated with care. Take special care to prevent scratches on the lapped faces of the primary and mating ring. Provide a very clean work area where the assembly will take place. Clean hands prior to assembly.

### INSTRUCTION STEPS:

#### Instructions for Installing a Mechanical Shaft Seal

1. Inspect mating ring pocket in seal housing ensuring it is clean, free of chips, and nick free, to provide a proper sealing surface. Isopropyl alcohol may be used to clean the surfaces if required.

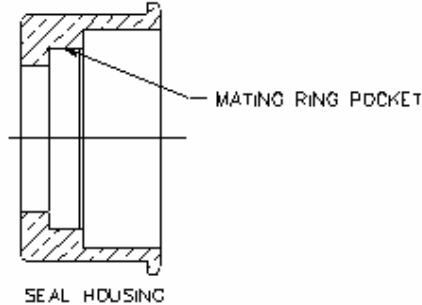

2. Inspect the pump shaft surface under the bellows, ensuring it is clean and nick free to provide a proper sealing surface. Isopropyl alcohol may be used to clean surface if required.

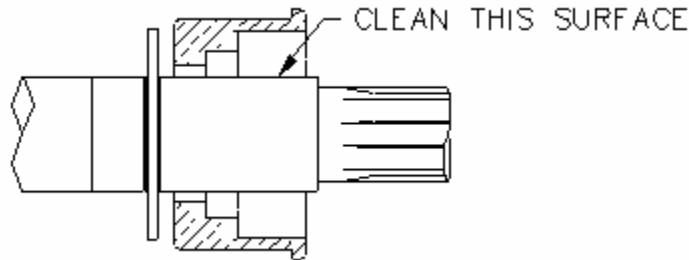

3. Lightly lubricate the o-ring on the mating ring with a single drop of P-80 water soluble rubber lubricant (do not over lubricate) and push it into the cavity using the recommended installation tool or other suitable plastic tube free of contaminants, firmly seating the mating ring square.

Note: The polished face of the mating ring must face out – away from the pump’s gear case. Try to not touch the polished sealing face with your fingers; the oils from your fingerprint can cause the seal to leak. Remove any P-80 from the sealing face after installation.

The approximate size of a drop should be between the sizes of these two circles.

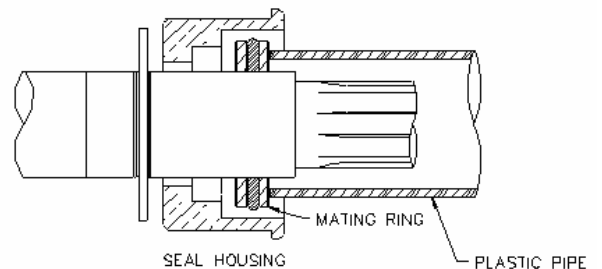
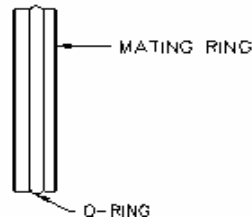

4. Clean the mating ring surface with isopropyl alcohol to remove any fingerprints and any other contaminants left on mating ring.

Note: Steps 5 – 9 need to all be completed with in 15 minutes or less.

5. Apply a small drop of P-80 rubber lubricant or water-soluble lubricant (not soapy water) to the inside diameter of the bellows assembly allowing it to be pushed easily into position.
6. Clean the polished sealing face of the primary ring with a clean lint free rag with isopropyl alcohol to remove all fingerprints and other contaminants.
7. Slide a seal save, similar to X6550, over the shaft splines to ensure that the seal is not damaged during installation. Place the primary ring and lubricated bellows assembly (without the spring) on the shaft, using a proper pusher - push the assembly into position so that the seal surfaces are in contact. Remove the seal save from the shaft.

The approximate size of a drop should be between the sizes of these two circles.

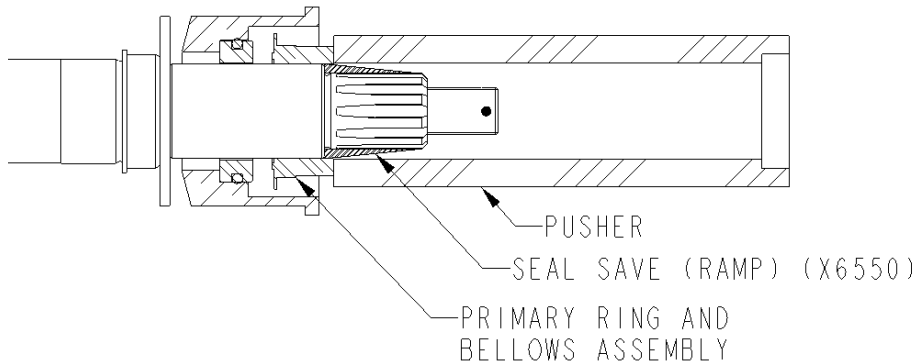
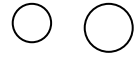

8. Put the spring in place, seated tight against the spring retainer on the primary ring.  
Note: Some springs may be slightly tapered, so one end fits the seal better than the other. The end of the spring that best fits the seal should go towards the seal to ensure even spring pressure all the way around.
9. Slide impeller onto impeller shaft, engage the spring into the groove of the impeller hub and install impeller washer, impeller nut, and stainless steel cotter key.

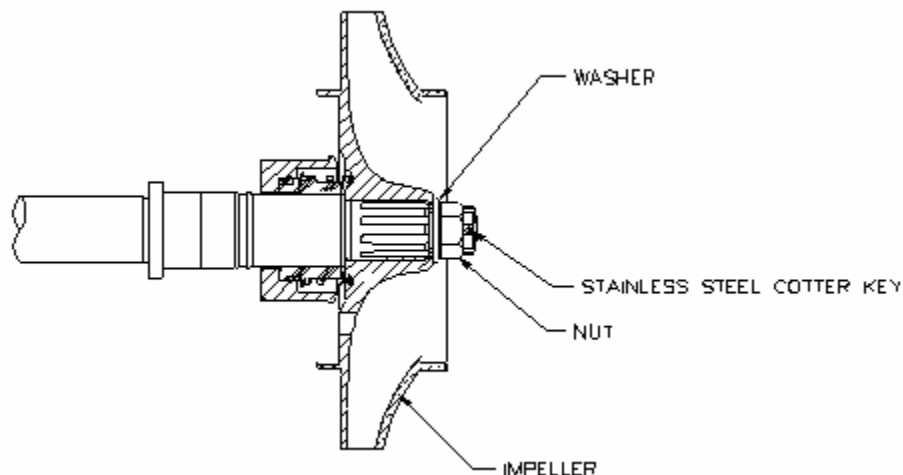

*\*\* Reference pump configuration for individual mechanical seal instructions.*

*\*\* Reference pump assembly drawings and pump assembly tips for further assembly.*

Note: If the seal leaks slightly after assembly, it may be necessary to run the pump for approximately 30 minutes at 50-60 psi to rinse out excess lubricant and other contaminants.

Once a mechanical seal has been installed, it is recommended that it not be reused.

If further information is needed, call **DARLEY** in Chippewa Falls, WI. at 800-634-7812 or 715-726-2650



## W. S. DARLEY & CO.

### DARLEY INJECTION TYPE STUFFING BOX ADJUSTMENT

**⚠ Prop 65 Warning:** This product contains lead, a chemical known to the State of California to cause cancer, birth defects, and other reproductive harm. Wash hands after handling.

**⚠ Caution:** Do not attempt to use anything but Darley injection packing. Using the wrong packing material in your pump may cause catastrophic failure of the pump shaft sealing components.

Only use W.S. Darley & Co.'s plastallic injection packing material. It is made of a special composition of shredded fibers, and a special bonding and lubricating compound.

It is important that the stuffing box is completely filled solid with packing and compressed firm during adjustment to prevent formation of voids and excessive leakage.

To pack the stuffing box when empty and assembled in the pump, remove the packing screw and nut assembly, and insert pellet form packing into the packing plunger guide. Replace the packing screw assembly and use a hand speed wrench to force the pellets into the gland. **DO NOT USE A POWER TOOL!** Repeat pellet additions while turning the impeller shaft by hand until resistance to turning is felt when the stuffing box is almost full. Continue turning packing screw by hand using a standard 6" long 9/16" end wrench until 4 lb. of force is felt at the end of the wrench. This is equivalent to 2 ft-lb or 24 in-lb torque. Continue turning until a few flakes of packing are extruded out the opening between the impeller shaft and the stuffing box hole. The gland is now ready for pressure testing or pumping.

After priming the pump with water, start the pump and raise the discharge pressure to 50 psi. Tighten the packing screw using a 6" long 9/16" end wrench until 4 lb. force is felt at the end of the wrench (24 in-lb torque). Continue operating the pump at 50 psi for 5 minutes to dissipate packing pressure against the shaft and permit cooling water to flow between the shaft and stuffing box hole. Make sure that water actually does come through before operating pump at any higher pressure. The normal drip rate may vary between 5 and 60 drops per minute.

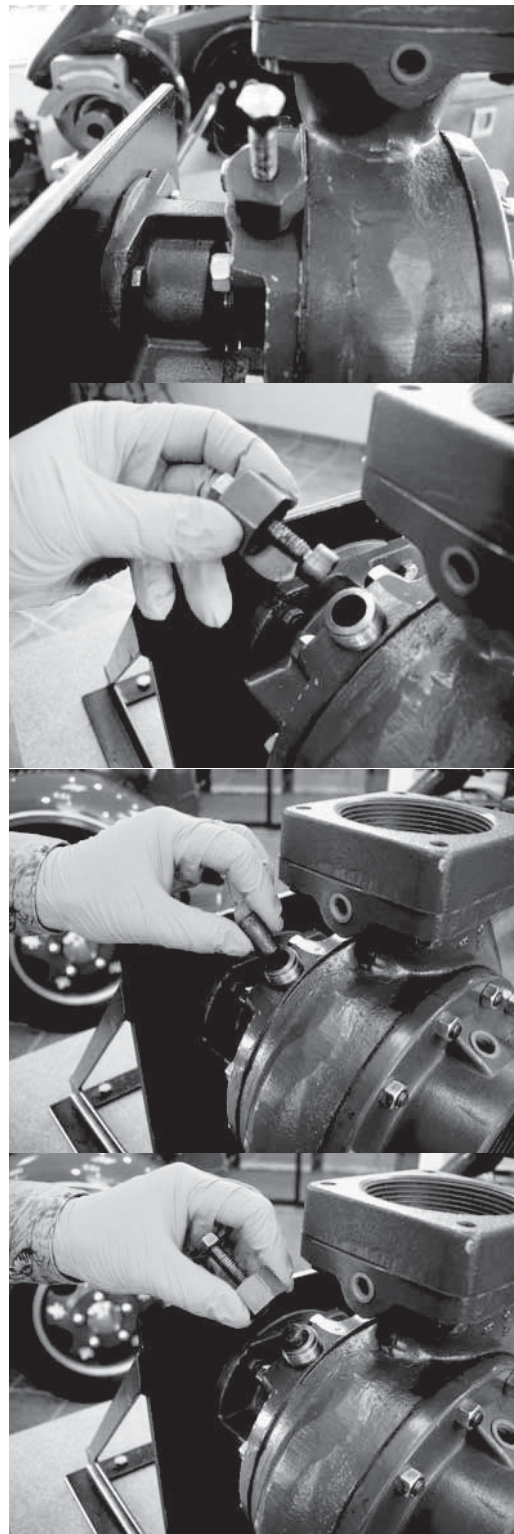

Operate the pump for 10 minutes at the highest normal operating pressure flowing sufficient water to prevent overheating. Do not run the pump blocked tight. Lower discharge pressure to 50 psi and repeat the packing screw tightening procedure outlined above.

The pump may now be operated for any time period required within its rated capacity. However, the drip rate should be monitored more frequently during the first few hours, and adjusted if necessary to achieve a stable flow rate. Several more adjustments may be required.



For a list of approximate quantity of packing pellets required by model (completely repacked), see below:

Model	Approximate # Packing Pellets
A	6
2BE	6
EM	15
H	8
JM	8
KD	10
KS	8
LD	15
LS	9
P	10
U2	5
U4	10

If further information is needed, call **W.S. DARLEY & CO.**  
at Chippewa Falls, WI. at 800-634-7812 or 715-726-2650

## SUMMARY OF THINGS TO REMEMBER

1. Always shift pump clutches with engine clutch disengaged.
2. Do not clash clutch gears when shifting.
3. Close booster valves, drain valves, cooling line and third stage discharge valve before attempting to prime the pump.
4. Always keep primer shut-off valve closed, except while priming.
5. Re-open and close primer valve to re-prime or eliminate trapped air from suction line.
6. Always drive a midship mounted split-shaft pump with truck transmission in the gear recommended by the chassis manufacturer.
7. Never run the pump without water in it except momentarily while priming.
8. Accelerate and retard speed of engine gradually.
9. Watch the engine temperature, and start the cooling water at the first signs of overheating.
10. Keep good gaskets in suction hoses, and handle carefully to avoid damage to coupling threads.
11. Air leakage into suction lines is the most frequent source of trouble when pumping from a suction lift (draft).
12. Always use a suction strainer when pumping from draft, and a hydrant strainer when pumping from a hydrant.
13. Foreign matter in impellers is a result of failure to use adequate strainers and is a common source of trouble.
14. Drain pump immediately after each run. This is especially critical in freezing conditions.
15. Do not run the pump long with discharge completely shut off.
16. Do not close a "Shutoff" nozzle when pumping with motor throttle wide open, unless relief valve or pressure regulator is set for the correct pressure.
17. Keep the pump gear case filled with oil to the level of the oil level plug/dipstick.
18. Check oil level in the pump transmission after every 25 hours of operation or 3 months, and changed it after every 50 hours of operation or 6 months.
19. In such equipped transmissions, once the oil is drained, remove the strainer screen oil sump fitting and thoroughly cleanse in a parts washer or with isopropyl alcohol, ensuring any debris is washed away.
20. If pump is equipped with a Darley plastallic (injection) packing shaft seal, check the drip rate frequently, and adjust according to the packing adjustment instruction, as required. The drip rate may vary between 5 and 60 drops per minute.
21. Work all suction and discharge valves often to ensure free and easy operation.

## OPERATION OF OPTIONAL HIGH PRESSURE STAGE

The sliding gear clutch which drives the optional high pressure stage is operated by a shift lever marked "FOG" for pumping position, and "OUT" for disengaged position. The shift lever must be locked in one or the other of these positions before the pump can be started.

The high pressure stage clutch must not be shifted while the main pump is running.

When the main pump is in operation, it must always be stopped (engine clutch disengaged) for shifting of the high pressure stage clutch either in or out.

The high pressure stage is always primed by pressure from the main pump.

The high pressure stage has a small by-pass line with a valve to the booster tank. Open the by-pass valve when running with the high pressure stage discharge lines completely shut off.

### HIGH PRESSURE BOOSTER PUMP DRAWING DLC0104

Rep. No.	Name of Part	Qty	Rep. No.	Name of Part	Qty
1	Inlet Pipe	1	26	Pipe Plug	1
2	Cotter Pin	1	27	Strainer Fitting	1
3	Impeller Pin	1	28	Inlet Tee	1
4	Flange O-ring	1	29	Close Nipple	1
5	Impeller Washer	1	30	Inlet Flange	1
6	Impeller Spacer	1	31	Seal Ring	1
7	Stuffing Box Head	1	32	Pump Casing	1
8	Pump Packing	10	33	Impeller	1
9	Water Slinger	1	34	Pump Casing Gasket	1
10	Impeller Shaft Oil Seal	1	35	Stuffing Box Gasket	1
11	Packing Cylinder	1	36	Idler Shaft Bearing	2
12	Gland Stud Piston	1	37	Shift Bar Oil Seal	1
13	Gland Nut	1	38	Gearcase Gasket	2
14	Packing Screw	1	39	Idler Shaft Spacer	1
15	Impeller Shaft Bearing	1	40	Idler Shaft	1
16	Impeller Shaft	1	41	Alignment Pin	2
17	Shift Collar	1	42	Idler Gear	1
18	Pump Drive Pinion	1	43	Gearcase Spacer	1
19	Gear Case	1	44	Idler Gear Key	1
20	Pinion Spacer	1	45	Oil Level & Fill plug	1
21	Impeller Shaft Bearing	1	46	Bearing Cap	1
22	Bearing Cap Gasket	2	47	Shift Bar O-ring	1
23	Bearing Cap	1	48	Shift Bar	1
24	Retaining Ring	2	49	Retaining Ring	2
25	Strainer Sleeve	1			

**IF FURTHER INFORMATION IS NEEDED, CALL W.S. DARLEY & CO. AT  
CHIPPEWA FALLS, WI. AT 800-634-7812 or 715-726-2650**

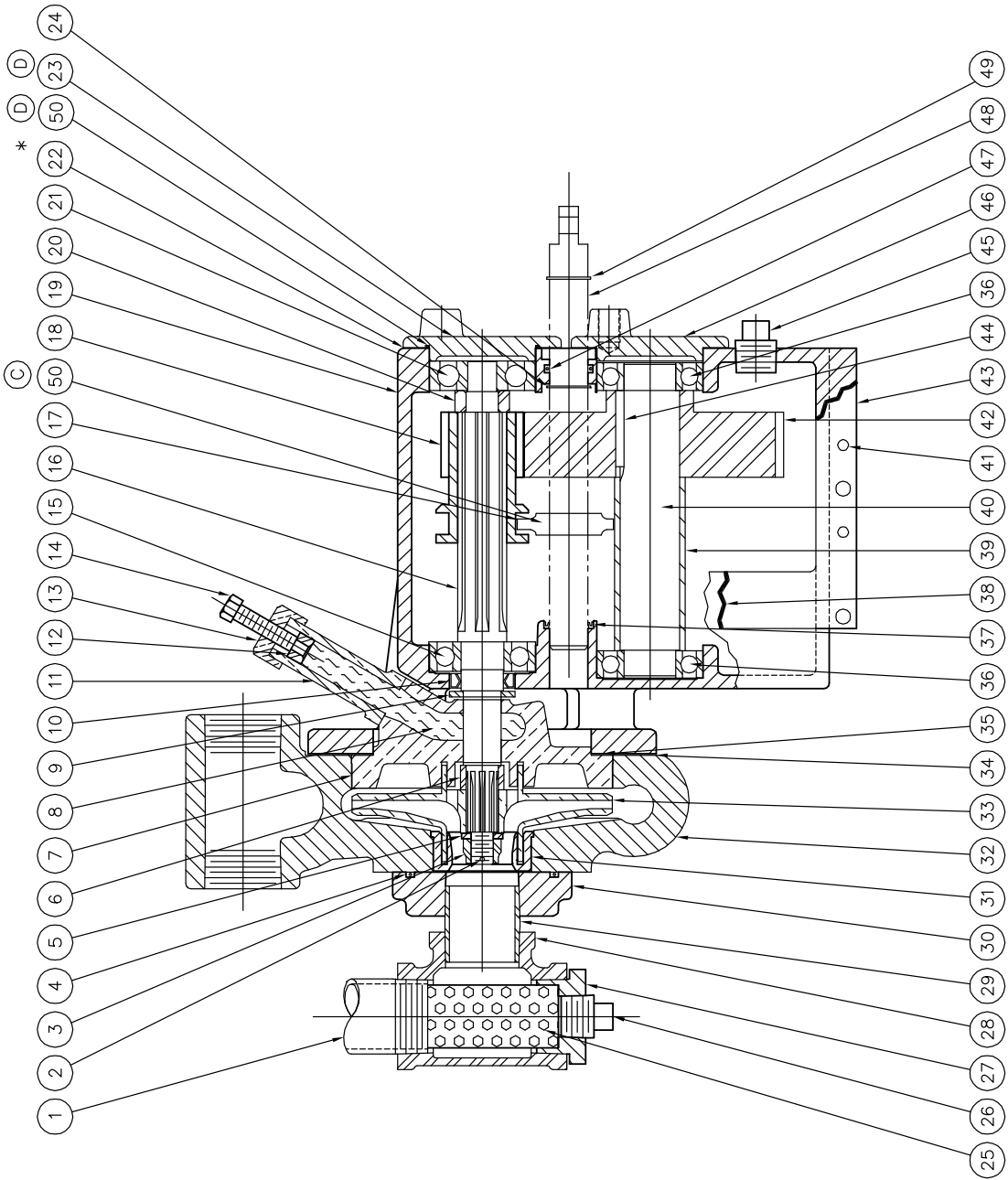

(D) REPL 2302600 W/ 2302604 AND 3601007 23SEP05 2005-285 CKE  
 (C) 2002-134 SHCS ADDED 09SEP02 JSS  
 \* GASKET REMOVED 5/94  
 (49) ADDED 3-23-90

TOLERANCE	W.S. DARLEY & CO.
EXCEPT	MELROSE PARK, IL - CHIPPewa FALLS, WI
FRAC DIM ±.01	
OD ±.01	
ANGLES ±1°	
DRN S. LEE	
CHKD	DATE AUG28,89
TROD	SCALE 1/2



OLD PART NO.  
 L88

THIS DESIGN IS THE PROPERTY OF W.S. DARLEY & CO. UNLESS AUTHORIZED REPRODUCTION IS PROHIBITED.  
 ALL DIMENSIONS IN INCHES UNLESS NOTED  
 DO NOT SCALE PRINT

DLC0104

# **WARNING: DO NOT USE THIS PUMP FOR HOSE TESTING**

## **OPERATING THE ENGINE**

After the pump has been primed, the engine speed should be increased gradually -- never jerk throttle wide open. Likewise, the engine speed should be decreased gradually when shutting down.

Watch the pump pressure gage and open throttle only enough to give the desired pressure. The pressure may rise high enough to burst the discharge hose, when using small nozzles, if the engine is given full throttle (except pumps equipped with pressure regulators set for desired pressure).

Never run engine at high speeds except when pump is primed and ready to discharge water.

## **COOLING THE ENGINE**

NFPA 1901 requires that a supplementary heat exchanger cooling system be provided. On most models, this heat exchanger is an integral part of the pump, and the installation of two hoses from the engine cooling system to the pump is all that is required.

On some models an external heat exchanger must be used. In that case two hoses from the engine cooling system and two lines from the pump will run to the heat exchanger.

The cooling line should not be opened until pressure develops in the pump, and pump should never be operated under heavy loads prolonged without an adequate supply of cooling water flowing.

Coolant temperatures should never be allowed to exceed 200° F while pumping and 180° F is usually taken as a safe operating temperature.

Always shut off cooling line when through pumping.

## **SUCTION STRAINERS**

A large suction strainer, which will prevent the passage of a body larger than the pump impeller ports, must always be used on the free end of the suction line when pumping from draft.

The small hydrant strainer must always be inserted in the suction manifold of pump, when pumping from hydrants and at all other times except when maximum capacity is required from draft.

Failure to use a strainer at all times when pumping will cause serious trouble by clogging the pump because, even in water mains, foreign matter is invariably present, and will be drawn into pump by the high velocity of the water entering.

## **SUCTION LINE**

The suction line of a fire pump can be the source of more operating difficulties than all the rest of the pump when working with a suction lift. Faults in the suction line which cause trouble in operation are as follows:

### **AIR LEAKS:**

A small amount of air, expanding in the vacuum of the suction line, displaces a considerable volume of water which subtracts from the capacity that the pump is able to deliver, making the priming difficult or causing the pump to lose its prime. Therefore, it is absolutely essential to keep the suction line and the suction side of pump casing air tight at all time when drafting water.



Air leakage into pump while operating is usually indicated by a rattling sound in pump casing, miniature explosions in stream issuing from the nozzle, or by losing of prime when operating at very low capacities.

The usual cause of leaky suction lines is carelessness in handling of suction hose. Bruising of hose threads by bumping against hard surfaces or sand in the coupling often prevents tightening of the joints up against the gaskets. The hose gaskets are often defective and are sometimes lost without being noticed by the operator.

### **INSUFFICIENT SUBMERGENCE:**

The free end of suction hose must be submerged to a sufficient depth to prevent the entrance of air that may be sucked down from the surface of the water to a considerable depth when operating at large capacities.

Entrance of air into suction lines in this manner is indicated by a small whirlpool, or vortex, on the surface of the water over the end of the hose.

A minimum submergence of 4 times the hose diameter to the upper holes in suction strainer is recommended where full capacity of pump is required. Where sufficient submergence is not possible, a board or sheet of metal laid over end of suction line will keep air from entering.

### **SUCTION LINE ENTRANCE TOO CLOSE TO BOTTOM:**

If the end of suction line is laid on the bottom of the source of supply, a part of the suction opening will be shut off; and if the bottom is soft, the hose will suck itself down into the earth closing more of the opening and loosening sand and mud to be carried into the pump.

The suction entrance should be suspended a foot or more above the bottom, or if this is not possible, it should be laid on a board or piece of sheet metal. A rope tied to the suction strainer is a convenient means of holding it off the bottom.

### **OBSTRUCTION OF SUCTION STRAINER BY FOREIGN MATTER:**

The high velocity of water entering the suction line will carry loose foreign bodies in against the strainer from a considerable distance. Therefore, all weeds and refuse should be removed from close proximity of the suction entrance.

### **SUCTION LINE TOO SMALL OR TOO LONG:**

The flow of water into the pump is opposed by the frictional resistance in the suction line. This friction loss must be added to the height of the pump above the water (static lift) to determine the "total lift" of the pump. When all of the vacuum in the pump (atmospheric pressure) is consumed in raising water through this total lift, then the limit of capacity has been reached. This capacity can be increased only by decreasing total lift. If the static lift cannot be reduced, then the friction loss must be reduced by using a shorter or larger suction hose.

The rated capacity of the pump is guaranteed for a static lift of 10 feet for ratings up to 1500 gpm, with 20 feet of recommended suction hose at 2000 feet. To increase the capacity without reducing the static lift, or to increase lift without sacrificing capacity, requires larger suction hose.

An excessively long suction line is a handicap to any pump, for besides reducing capacity through the added friction loss, it retards priming and it produces a detrimental effect known as "cavitation". This means a separation of the water column in the pump suction, or void spaces, produced by the inertia of the heavy mass of water in the line resisting sudden change in the velocity when the pump starts to deliver or when discharge valves are opened or closed. This phenomenon reduces

capacity further, and usually sets up a vibratory motion and “water hammer” as the water surges in and out of the void spaces.

When operating with a long suction line, the driving engine should be accelerated gradually, the discharge gates opened gradually, and the capacities of the pump should be held down to within the range of smooth performance.

**AIR TRAP IN SUCTION LINE:**

If the suction line is laid so that part of it is higher than any other part that is nearer to the pump, as when hose is laid over a high bridge rail, an air trap is formed at the highest part of the hose from which the air cannot be sucked out by the primer. This trapped air is expanded and carried into the pump with the first rush of water causing the pump to immediately lose its prime.

If suction line cannot be laid so that it slopes all the way from pump to water, it can still be primed easily by simply allowing the primer to continue to function until all the trapped air in the hose has been carried into the pump and picked up by the primer.

## TESTING FOR AIR LEAKS

Tests for leakage should be made with the suction hose attached and capped, discharge gate open, and all other openings closed tightly.

Run electric priming pump with primer shut-off valve open, until 22" of Hg is shown on the gage. The vacuum should hold for no more than 10" of drop in 5 minutes before satisfactory performance of pump can be expected.

If excessive leakage of air occurs, the source of leaks can be located by shutting off primer motor, with vacuum at its highest point, and listening for the hiss of air.

In the absence of a vacuum gage, the vacuum in pump may be judged by closing suction opening with the flat of hand or a rubber pad.

Water or air pressure may be applied to pump casing to test for air leakage if more convenient. DO NOT pressurize with air beyond 10 PSI

## SOURCE OF WATER SUPPLY

Water may be drafted from a pond, lake, stream, cistern, stock tank, or well; but whatever the source, the static lift must not exceed 20 feet from the center of the pump to the surface of the water and a lift not exceeding 10 feet is recommended. The source of supply should be reasonably clear and free from foreign matter. It is recommended that all water holes, which may be needed for fire protection, be deepened if necessary and kept free from weeds and refuse. In many fire protection areas, cisterns or reservoirs are built and allowed to fill up with rain water to be used in emergencies.

## PUMPING IN COLD WEATHER

The first insurance against cold weather trouble is to keep fire apparatus stored in heated quarters. All water must be eliminated from pump casing and primer line between periods of operations.

When setting up for pumping, unnecessary delays should be avoided by having thoroughly trained pump operators. Be sure that primer and booster lines are kept closed until ready for use. Having discharge lines ready so that pump may be started as soon as it have become primed. Do not stop flow of water through the pump until ready to drain and return to the station.

Engine Coolant from the engine circulated through the heater jacket in pump casing prevents all ordinary freezing troubles.

## WHEN FINISHED PUMPING

Drain water out of pump casing immediately. (Drain valve is located at lowest point in pump casing, and usually accessible from underneath operators panel.)

Don't forget to close all drain cocks after all water has been drained out. Trouble in priming will follow on the next run if this is forgotten.

Shut off cooling line to make pump ready for priming again.

If pump transmission is equipped with a transmission cooler it must be drained also. If the master drain is located below the cooler outlets it can be connected to the master drain, if not, two separate drains must be connected to the transmission cooler. **Failure to drain transmission cooler may result in water in the gearcase if water in the cooling coil freezes.**

If pump is equipped with a heat exchanger, drain heat exchanger using gravity and vacuum drain on all trucks as follows: Close all open lines and drain cocks. Open cooler valve and open air vent at top or drain cock at bottom of heat exchanger depending on model. With the pump air-tight, open primer with engine running for about a minute and then close primer. Drain pump of water which was deposited when heat exchanger and lines were being drained.

Pump not often used for fire service should be inspected and run periodically to ensure that they will be in readiness for an emergency.

## **PUMPING SALT WATER**

The pump should be flushed out with fresh water immediately after pumping salt water to prevent excessive rusting. (Except pumps which are built of special materials, such as bronze, to resist the corrosive action of the brine.)

When measuring sea water with a Pitot Gage, capacities shown in Table No. 2 should be discounted approximately 1 1/2% to determine the correct capacity.

A centrifugal pump will show 3% higher pressure and require 3% more power when handling sea water than when handling fresh water if operated at the same speed and capacity.

## **TESTING OF EQUIPMENT FOR PRACTICE**

It frequently happens that operators of fire apparatus, who are not thoroughly familiar with its operations, become confused under the stress of emergency and neglect some little detail that may cause trouble or delay in getting the equipment into operation. Therefore, we urge that practice tests be conducted repeatedly until operators are thoroughly trained. More than one person in the department should be a competent operator.

Practice should include pumping from low lifts, high lifts with short and long suction lines, with suction line elevated to form an air trap, and from hydrants, at large and small capacities.

It is important to note the effects of air leaks in hose, insufficient submergence and restriction of suction line. (Suction line can be restricted by placing a can or other strong closure around the suction strainer).

**NEVER BREAK OR RESTRICT SUCTION OR ALLOW AIR TO ENTER SUCTION LINE WHILE ENGINE IS OPERATING WITH THROTTLE OPEN.** This will release the load and allow engine to run away.

Do not allow personnel to hold a large nozzle while working at high pressures for serious accidents may result if hose breaks loose.

## **MEASURING PUMP PERFORMANCE**

Pump performance is measured by the quantity of water it can deliver per minute against a certain pressure called "Total Head" or "Net Pump Pressure", as it is usually termed in fire pump testing.

The net pump pressure is the sum of the pump discharge pressure, as shown on the pressure gage with which the pump is regularly equipped, and the total suction lift converted to equivalent pounds per square inch. If pump is operating from a hydrant, the net pump pressure is the discharge pressure less the incoming pressure from hydrant measured at the suction entrance of pump.

Capacity of fire pump is measured in gallons per minute. The usual method of measurement is to determine the pressure of the jet of water leaving a given size of nozzle by means of a "Pitot Gage" from which the capacity is computed mathematically.

A Pitot Gage consists of a small tube adapted to a point directly into the hose nozzle from the center of the issuing stream, the other end of the tube being connected to an accurate pressure gage.

The nozzle jet drives straight into the Pitot tube and converts the velocity of the jet to pressure which is an accurate measure of velocity of the water as it leaves the nozzle. The tip of the Pitot tube should be one-half the diameter of the nozzle away from nozzle tip while taking reading. Table No. 2 gives nozzle capacities for various Pitot Gage readings.

If a Pilot gage is not available approximate pump capacities can be determined by reference to Table No.3

## ACCEPTANCE TESTS

Acceptance tests require continuous tests of three hours duration: 2 hours at 100% rated capacity and 150 PSI net pump pressure; one-half hour at 70% capacity and 200 PSI; one-half hour at 50% capacity and 250 PSI; and a spurt test at 100% capacity and 165 PSI.

Table No. 1 shows recommended set-ups and gage readings for rating tests.

To adjust nozzle pressure for the correct capacity, while maintaining the correct pump pressure, it is necessary to make simultaneous adjustments of engine throttle and the discharge gate valve, partially closing the latter until just the right discharge resistance is built up.

## ENGINES

A fire pump imposes heavy loads on the engine that drives it, sometimes absorbing all of the power the engine is capable of delivering at full throttle. Continuous pumping gives the engine no time to rest. Therefore, a new engine and pump unit must be thoroughly broken-in before it is required to deliver prolonged maximum pump performance.

We recommend a minimum break in period of 20 hours at light pumping loads, with occasional spurt tests and interruptions. Temperature and lubrication should be checked during this period.

Engine manufacturers' power ratings usually show maximum performance of a selected, factory adjusted engine, operating without fan, generator, muffler or other accessories, and corrected for "ideal" conditions, i.e. sea level barometer (29.92" of mercury) 60°F and high humidity. Therefore, the actual power delivered by an average truck mounted engine is considerably lower than the manufacturers' rating, and allowances must be made in predicting pump performance.

## EFFECTS OF ATMOSPHERIC CONDITIONS ON ENGINE AND PUMP PERFORMANCE

Each one inch of drop in Barometric pressure or each 1000 feet of elevation of the pumping site reduces engine power approximately 3 1/2% for engines not equipped with a turbo charger.

Each 12° rise in temperature above 60° F of carburetor intake air reduces engine power approximately 1%.

Lowering of humidity reduces power slightly.

Each one inch drop in Barometric pressure or each 1000 feet of elevation reduces the maximum possible static lift of a pump approximately one foot.

Temperature of the water supply affects the attainable suction lift of a pump. The effect is slight at low water temperatures but becomes increasingly detrimental as the temperature rises.

A 10° rise from 70°F will subtract about 1/2 foot from the maximum attainable suction lift, while an equal rise from 100°F will reduce the lift at least 1 1/2 feet.

Temperature is an important consideration when pumping from a test pit where the water is heated by recirculation.

**IF FURTHER INFORMATION IS NEEDED, CALL W.S. DARLEY & CO. AT  
CHIPPEWA FALLS, WI. AT 800-634-7812 or 715-726-2650**

## DEFINITIONS

HEAD OF WATER -- vertical depth of water measured in feet or in pressure per unit or area. In hydraulics, head always represents pressure and it is expressed interchangeably in feet of water or pounds per square inch and sometimes in inches of depth of mercury.

STATIC HEAD -- the pressure that is exerted by a stationary column of water of a given height or depth.

TOTAL HEAD OR TOTAL DYNAMIC HEAD -- the maximum height above the source of supply to which the pump would elevate the water plus all the resistance to flow in the pipe or hose line.

DISCHARGE HEAD -- the pressure measured at the discharge outlet of a pump.

SUCTION HEAD -- the positive pressure measured at the suction entrance of a pump (when pumping from an elevated tank or hydrant).

VELOCITY HEAD -- the equivalent pressure represented by fluid in motion as measured by means of a Pitot Gage.

STATIC LIFT -- the vertical height of the center of the pump above the source of supply (when pump from draft).

TOTAL SUCTION LIFT -- the static lift plus the friction in suction line plus entrance losses.

NET PUMP PRESSURE -- the total dynamic head of the pump.

EFFECTIVE NOZZLE PRESSURE -- the pump discharge pressure minus hose friction plus or minus the difference in elevation above or below pump.

WATER HORSEPOWER - the theoretical power required to deliver a given quantity of water per minute against a given head.

BRAKE HORSEPOWER -- Actual power as delivered by a motor or engine to a driven machine.

PUMP EFFICIENCY -- The quotient of the water horsepower divided by brake horsepower required to produce it.

WATER HAMMER -- a series of shock waves produced in a pipeline or pump by a sudden change in water velocity. A sudden change in flow velocity can result from rapid closure of valves. A pressure wave is set up which travels back and forth in the water column at extremely high speed producing rapid vibrations that may be violent and destructive if the water column is long.

THE MAXIMUM THEORETICAL LIFT of a pump is 34 feet, which is the pressure of the atmosphere at sea level. The maximum practical total lift at sea level is 20 to 25 feet (depending on the type and condition of the pump) and this decreases with drops in barometric pressure.

## **OPERATING CHARACTERISTICS OF PUMPS**

**CENTRIFUGAL PUMPS:** A centrifugal pump develops pressure by centrifugal force of the liquid rotating in the impeller wheel. The pressure developed depends upon the peripheral speed of the impeller (increasing as the square of the speed) and it remains fairly constant over a wide range of capacities up to the maximum output of the pump, if speed remains constant.

If the discharge outlet of a centrifugal pump is entirely shut off, with speed kept constant, there is a small rise in pressure, the water churns in the pump casing and the power drops to a low value. If the discharge is opened wide, with little resistance to flow the pressure drops while the capacity and power both increase to their maximum.

A centrifugal pump is an extremely simple mechanism mechanically, but rather complex hydraulically; in that many factors enter into the design of the impeller and water ways which will affect the pump's efficiency.

**DISPLACEMENT PUMPS:** Rotary and piston pumps are termed "Positive Displacement" pumps because each revolution displaces or discharge (theoretically) an exact amount of liquid, regardless of the resistance. The capacity is, therefore, proportional to the number of revolutions of the pump per minute and independent of the discharge pressure except as it is reduced by "slip" (leakage past the pistons or rotors). For a given speed the power is directly proportional to the head. If the discharge is completely shut off, the pressure, power, and torque climb indefinitely until the drive power is stalled or breakage occurs.

Slip is the greatest factor affecting efficiency of a displacement pump, and this factor is greatly influenced by the condition of and wears on the working parts.

**IF FURTHER INFORMATION IS NEEDED, CALL W.S. DARLEY & CO. AT  
CHIPPEWA FALLS, WI. AT 800-634-7812 or 715-726-2650**



## CONVERSION FACTORS

One pound per square inch	=	2.31 feet of water
	=	2.04 inches of mercury
	=	27.7 inches of water
One foot of water	=	0.43 pounds per square inch
One inch of mercury	=	1.13 feet of water
	=	0.49 pounds per square inch
One cubic foot of water	=	62.4 pounds
	=	7.5 gallons
One gallon of water	=	231 cubic inches
	=	0.13 cubic feet
	=	8.34 pounds
	=	3.8 liters
One Imperial Gallon	=	1.2 U.S. gallons
Atmospheric Pressure (Sea Level)	=	14.8 pounds per square inch
	=	29.9 inches of mercury
	=	34 feet of water

**TABLE NO. 1  
NFPA 1901 TEST**

Class A							
TEST No.	GPM	Recom- mended Nozzles	Min. Nozzle Press. PSI	Min. Disch. Press. PSI	Min. Net Pump Press. PSI	Disch. Lines	Suction Hose
250 GPM Fire Pump							
1	250	(1), 1"	72	143	150		
2	175	(1), 7/8"	62	194	200	(1), 50'	20' of 3"
3	125	(1), 3/4"	56	244	250		
4	250	(1), 1"	72	158	165		
350 GPM Fire Pump							
1	350	(1), 1-1/4"	58	144	150		
2	245	(1), 1"	69	195	200	(1), 50'	20' of 4"
3	175	(1), 7/8"	62	245	250		
4	350	(1), 1-1/4"	58	159	165		
500 GPM Fire Pump							
1	500	(1), 1-1/2"	57	143	150	(1), 50'	
2	350	(1), 1-1/4"	58	194	200		20' of 4"
3	250	(1), 1"	72	245	250		
4	500	(1), 1-1/2"	57	158	165		
750 GPM Fire Pump							
1	750	(1), 1-3/4" or (2), 1-1/4"	68 66	142	150	(2), 50'	
2	525	(1), 1-1/2"	62	193	200	or	20' of 4-1/2"
3	375	(1), 1-1/4"	66	244	250	(2), 100'	
4	750	(1), 1-3/4" or (2), 1-1/4"	68 66	157	165	Siamesed	
1000 GPM Fire Pump							
1	1000	(1), 2" or (2), 1-1/2"	71 57	142	150	(2), 50'	
2	700	(1), 1-3/4" or (2), 1-1/4"	60 58	193	200	or	20' of 5"
3	500	(1), 1-1/2"	57	244	250	(3), 100'	
4	1000	(1), 2" or (2), 1-1/2"	71 57	157	165	Siamesed	

Min. discharge pressures listed above are for pumps operating with full 10' static suction lift. These pressures must be increased by 1 PSI for each 2.3 ft. less than 10' of lift.

**TABLE NO. 1**  
**NFPA 1901 TEST**

Class A							
TEST No.	GPM	Recommended Nozzles	Min. Nozzle Press. PSI	Min. Disch. Press. PSI	Min. Net Pump Press. PSI	Disch. Lines	Suction Hose
1250 GPM Fire Pump							
1	1250	(1), 2-1/4" or (2), 1-1/2"	69 88	143	150	(3), 50'	20' of 6"
2	875	(1), 2" or (2), 1-3/8"	55 61	194	200	or (3), 100'	
3	625	(1), 1-1/2" 2-1/4"	88	245	250	and (1), 50'	
4	1250	or (2), 1-1/2"	69 88	158	165	Siamesed	
1500 GPM Fire Pump							
1	1500	(2), 1-3/4" or (3), 1-1/2"	68 57	142	150	(3), 50'	20' of
2	1050	(1), 2" or (2), 1-1/2"	78 62	194	200	or (3), 100'	6" Min or
3	750	(1), 1-3/4" or (2), 1-1/4"	68 66	245	250	and (1), 50'	(2) 20' of
4	1500	(2), 1-3/4" or (3), 1-1/2"	68 57	157	165	Siamesed	6" Max

Min. discharge pressures listed above are for pumps operating with full 10' static suction lift. These pressures must be increased by 1 PSI for each 2.3 ft. less than 10' of lift.

**TABLE NO. 2**  
**DISCHARGE FROM SMOOTH BORE NOZZLE**  
**Pressures measured by Pitot gage.**

Nozzle Pressure PSI	1/4	3/8	1/2	5/8	3/4	7/8	1	1 1/8	1 1/4	1 3/8	1 1/2	1 5/8	1 3/4	2	2 1/4	2 1/2
	GALLONS PER MINUTE DELIVERED															
5	4	9	16	26	37	50	66	84	103	125	149	175	203	266	337	415
6	4	10	18	28	41	55	72	92	113	137	163	192	223	292	369	455
7	4	11	19	30	44	59	78	99	122	148	176	207	241	315	399	491
8	5	11	21	32	47	64	84	106	131	158	188	222	257	336	427	525
9	5	12	22	34	50	67	89	112	139	168	200	235	273	357	452	557
10	6	13	23	36	53	71	93	118	146	177	211	248	288	376	477	587
12	6	15	25	40	58	78	102	130	160	194	231	271	315	412	522	643
14	7	15	27	43	63	84	110	140	173	210	249	293	340	445	564	695
16	7	16	29	46	67	90	118	150	185	224	267	313	364	475	603	743
18	7	17	31	49	71	95	125	159	196	237	283	332	386	504	640	788
20	8	18	33	51	75	101	132	167	206	250	298	350	407	532	674	830
22	8	19	34	54	79	105	139	175	216	263	313	367	427	557	707	871
24	8	20	36	56	82	110	145	183	226	275	327	384	446	582	739	909
26	9	21	37	59	85	115	151	191	235	286	340	400	464	606	769	947
28	9	21	39	61	89	119	157	198	244	297	353	415	481	629	799	982
30	10	22	40	63	92	123	162	205	253	307	365	429	498	651	826	1017
32	10	23	41	65	95	127	167	212	261	317	377	443	514	673	854	1050
34	11	23	43	67	98	131	172	218	269	327	389	457	530	693	880	1082
36	11	24	44	69	100	135	177	224	277	336	400	470	546	713	905	1114
38	11	25	45	71	103	138	182	231	285	345	411	483	561	733	930	1144
40	11	26	46	73	106	142	187	237	292	354	422	496	575	752	954	1174
42	11	26	47	74	109	146	192	243	299	363	432	508	589	770	978	1203
44	12	27	49	76	111	149	196	248	306	372	442	520	603	788	1000	1231
46	12	28	50	78	114	152	200	254	313	380	452	531	617	806	1021	1259
48	12	28	51	80	116	156	205	259	320	388	462	543	630	824	1043	1286
50	13	29	52	81	118	159	209	265	326	396	472	554	643	841	1065	1313
52	13	29	53	83	121	162	213	270	333	404	481	565	656	857	1087	1339
54	13	30	54	84	123	165	217	275	339	412	490	576	668	873	1108	1364
56	13	30	56	86	125	168	221	280	345	419	499	586	680	889	1129	1389
58	13	31	56	87	128	171	225	285	351	426	508	596	692	905	1149	1414
60	14	31	57	89	130	174	229	290	357	434	517	607	704	920	1168	1437
62	14	32	58	90	132	177	233	295	363	441	525	617	716	936	1187	1462
64	14	32	59	92	134	180	237	299	369	448	533	627	727	951	1206	1485
66	14	33	60	93	136	182	240	304	375	455	542	636	738	965	1224	1508
68	14	33	60	95	138	185	244	308	381	462	550	646	750	980	1242	1531
70	15	34	61	96	140	188	247	313	386	469	558	655	761	994	1260	1553
72	15	34	62	97	142	191	251	318	391	475	566	665	771	1008	1278	1575
74	15	35	63	99	144	193	254	322	397	482	574	674	782	1023	1296	1597
76	15	35	64	100	146	196	258	326	402	488	582	683	792	1036	1313	1618
78	15	36	65	101	148	198	261	330	407	494	589	692	803	1050	1330	1639

**TABLE NO. 2**  
**DISCHARGE FROM SMOOTH BORE NOZZLE**  
**Pressures measured by Pitot gage.**

Nozzle Pressure PSI	1/4	3/8	1/2	5/8	3/4	7/8	1	1 1/8	1 1/4	1 3/8	1 1/2	1 5/8	1 3/4	2	2 1/4	2 1/2
	GALLONS PER MINUTE DELIVERED															
80	16	36	66	103	150	201	264	335	413	500	596	700	813	1063	1347	1660
82	16	37	66	104	152	204	268	339	418	507	604	709	823	1076	1364	1681
84	16	37	67	105	154	206	271	343	423	513	611	718	833	1089	1380	1701
86	16	37	68	107	155	208	274	347	428	519	618	726	843	1102	1396	1721
88	16	38	69	108	157	211	277	351	433	525	626	735	853	1115	1412	1741
90	17	39	70	109	159	213	280	355	438	531	633	743	862	1128	1429	1761
92	17	39	70	110	161	215	283	359	443	537	640	751	872	1140	1445	1780
94	17	39	71	111	162	218	286	363	447	543	647	759	881	1152	1460	1800
96	17	40	72	113	164	220	289	367	452	549	654	767	890	1164	1476	1819
98	17	40	73	114	166	223	292	370	456	554	660	775	900	1176	1491	1838
100	18	41	73	115	168	225	295	374	461	560	667	783	909	1189	1506	1856
105	18	42	75	118	172	230	303	383	473	574	683	803	932	1218	1542	1902
110	19	43	77	121	176	236	310	392	484	588	699	822	954	1247	1579	1947
115	19	43	79	123	180	241	317	401	495	600	715	840	975	1275	1615	1991
120	19	44	80	126	183	246	324	410	505	613	730	858	996	1303	1649	2033
125	20	45	82	129	187	251	331	418	516	626	745	876	1016	1329	1683	2075
130	20	46	84	131	191	256	337	427	526	638	760	893	1036	1356	1717	2116
135	21	47	85	134	195	262	343	435	536	650	775	910	1056	1382	1750	2157
140	21	48	87	136	198	266	350	443	546	662	789	927	1076	1407	1780	2196
145	21	49	88	139	202	271	356	450	556	674	803	944	1095	1432	1812	2235
150	22	50	90	141	205	275	362	458	565	686	817	960	1114	1456	1843	2273

**TABLE NO. 3**  
**Approximate Discharge Flow From Different Nozzles**  
**At the end of Fifty Feet of Average, 2 1/2”**  
**Rubber Lined Fire Hose, for Various**  
**Pump Pressures with Discharge**  
**Valve Wide Open**

PUMP PRESSURE LBS	SIZE OF NOZZLE & GALLONS PER MINUTE						
	3/4	7/8	1	1 1/8	1 1/4	1 3/8	1 1/2
30	90	119	153	187	217	250	282
40	103	137	177	216	253	290	327
50	115	153	198	242	284	325	367
60	126	168	216	265	311	357	402
70	136	182	234	287	337	385	435
80	145	194	250	308	361	414	465
90	154	206	265	325	383	437	492
100	162	217	280	343	405	462	520
110	171	228	295	360	425	485	549
120	179	239	307	377	444	510	572
130	186	249	318	392	462	530	596
140	193	258	330	407	480	549	618
150	200	267	341	421	497	567	
175	215	288	374	455	538		
200	230	309	395	486			
225	243	328	420				
250	257	345					

This table is offered as an aide in testing pump performance where facilities for accurate measurement of capacity are not available. The capacities given above are conservative, and will not vary more than 5% from actual capacities with any of the standard hose that might be used.

**TABLE NO. 4**

**Pump or Hydrant Pressure required to give  
Effective Nozzle Pressure through various  
Lengths of Rubber Lined Hose.**

Size of Hose		1 1/2				2		2 1/2				3		
Size of Nozzle		1/4	3/8	1/2	5/8	5/8	3/4	3/4	7/8	1	1 1/4	1 1/2	1 1/4	1 1/2
Nozzle Press PSI	Length of Hose Feet	PUMP OR HYDRANT PRESSURE - PSI												
40	100	45	43	48	60	42	50	44	46	51	64	88	51	62
	200	49	46	56	79	43	60	47	52	60	86	130	59	78
	400	58	51	73	118	46	79	53	62	79	129	212	75	110
	600	67	57	89	158	50	99	59	74	97	172		92	143
	800	76	62	106	196	53	119	65	85	116	215		108	176
	1000	85	68	122	235	56	138	72	96	134	258		124	208
	1500	108	72	142		64	187	87	118	181			165	
	2000	130	96	204		72	226	103	151	227			205	
60	100	67	64	72	89	63	73	65	69	75	95	132	76	92
	200	74	68	84	117	65	86	70	78	89	126	196	88	115
	400	87	76	107	173	69	112	79	94	116	188		111	161
	600	101	85	131	231	74	138	88	111	143	250		135	208
	800	114	93	153		79	164	98	127	170			158	
	1000	127	101	178		83	190	107	143	197			182	
	1500	161	122	237		95	155	130	184	264				
	2000	195	142			106		153	225					
80	100	88	85	96	117	83	99	87	92	99	126	175	101	103
	200	97	91	112	154	86	117	93	103	115	167		116	154
	400	115	102	143	228	92	154	105	125	148	249		147	
	600	132	112	174		98	191	117	147	181			178	
	800	150	123	206		104	228	129	167	214			209	
	1000	167	134	238		110		141	191	247				
	1500	211	161			125		171	245					
	2000	254	188			140		201						
100	100	111	107	120	146	104	123	108	115	125	157		126	152
	200	122	113	139	192	108	145	116	128	150	209		146	190
	400	143	127	177	284	115	190	130	154	200			184	
	600	165	140	217		123	235	145	180	250			223	
	800	186	154	256		131		159	206					
	1000	208	167			138		174	232					
	1500	262	200			157		211						
	2000		234			175		253						

**TABLE NO. 1  
NFPA 1901 TEST**

Class A							
TEST No.	GPM	Recom- mended Nozzles	Min. Nozzle Press. PSI	Min. Disch. Press. PSI	Min. Net Pump Press. PSI	Disch. Lines	Suction Hose
1750 GPM Fire Pump							
1	1750	(2), 2" or (3), 1-1/2"	55 76	143	150	(4), 50'	(2) 20' of 6"
2	1225	(2), 1-1/2" or (3), 1-1/4"	61 84 79	194	200	or	
3	875	(1), 2" or (2), 1-3/8"	55 61	245	250	(4), 100'	
4	1750	(2), 2" or (3), 1-1/2"	55 76	158	165		
2000 GPM Fire Pump							
1	2000	(2), 2" or (4), 1-1/2"	71 57	147	150	(4), 50'	(2) 20' of 6"
2	1400	(2), 1-3/4" or (3), 1-1/2"	60 49	199	200	or	
3	1000	(1), 2" or (2), 1-1/2"	71 57	249	250	(4), 100'	
4	2000	(2), 2" or (4), 1-1/2"	71 57	163	165		
2250 GPM Fire Pump							
1	2250	(2), 2-1/4"	56	144	150	(2 Groups) (3), 100'	20' of 8"
2	1575	(2), 1-3/4"	76	196	200	Siamesed	
3	1125	(2), 1-1/2"	72	246	250		
4	2250	(2), 2-1/4"	56	153	165		

Min. discharge pressures listed above are for pumps operating with full 10' static suction lift. These pressures must be increased by 1 PSI for each 2.3 ft. less than 10' of lift.



**TABLE NO. 1  
NFPA 1901 TEST**

Class A							
TEST No.	GPM	Recom- mended Nozzles	Min. Nozzle Press. PSI	Min. Disch. Press. PSI	Min. Net Pump Press. PSI	Disch. Lines	Suction Hose
2500 GPM Fire Pump							
1	2500	(2), 2-1/4"	69	144	150	(2 Groups) (3), 100'	20' of 8"
2	1750	(2), 2"	55	195	200	Siamesed	
3	1250	(2), 1-1/2"	88	246	250		
4	2500	(2), 2-1/4"	69	159	165		
3000 GPM Fire Pump							
1	3000	(2), 2-1/2"	65	146	150	(2 Groups) (3), 100'	(2) 20' of 8"
2	2100	(2), 2"	78	196	200	Siamesed	
3	1500	(2), 1-3/4"	68	247	250		
4	3000	(2), 2-1/2"	65	161	165		
3500 GPM Industrial Fire Pump							
1	3500	(2), 2-1/2" and (1), 2-1/4"	45 44	95	100	(2 Groups) (3), 100' Siamesed	(2) 20' of 8"
2	2450	(2), 2-1/4"	67	146	150	& (2)-50'	
3	1750	(2), 2"	55	197	200	Siamesed	

Min. discharge pressures listed above are for pumps operating with full 10' static suction lift. These pressures must be increased by 1 PSI for each 2.3 ft. less than 10' of lift.

**IF FURTHER INFORMATION IS NEEDED, CALL W.S. DARLEY & CO. AT  
CHIPPEWA FALLS, WI. AT 800-634-7812 or 715-726-2650**

**TABLE NO. 5  
REACH OF FIRE STREAMS**

<b>Size of Nozzle</b>	<b>1/4"</b>	<b>3/8"</b>	<b>1/2"</b>	<b>5/8"</b>	<b>3/4"</b>	<b>7/8"</b>	<b>1"</b>	<b>1-1/4"</b>	<b>1-1/2"</b>
-----------------------	-------------	-------------	-------------	-------------	-------------	-------------	-----------	---------------	---------------

**NOZZLE  
PRESSURE      EFFECTIVE VERTICAL REACH - Feet**

40	30	35	40	50	59	62	64	65	69
60	35	40	45	60	74	77	79	84	87
80	38	42	48	65	81	85	89	94	96
100	40	44	50	68	84	89	94	100	102

**NOZZLE  
PRESSURE      MAXIMUM VERTICAL REACH - Feet**

40	60	65	70	75	78	79	80	80	80
60	70	75	85	95	105	106	108	110	110
80	78	83	95	105	117	125	132	140	140
100	80	88	100	110	122	135	145	155	155

**NOZZLE  
PRESSURE      EFFECTIVE HORIZONTAL REACH - Feet**

40	20	25	30	40	44	50	55	62	66
60	25	32	37	50	54	61	67	75	80
80	28	35	40	57	62	70	76	84	88
100	30	37	42	60	66	76	84	93	95

**NOZZLE  
PRESSURE      MAXIMUM HORIZONTAL REACH - Feet**

40	65	80	90	100	108	120	125	138	140
60	80	95	95	120	127	142	156	176	183
80	90	105	105	135	143	160	175	201	210
100	95	110	110	140	153	180	205	215	223

**TABLE NO. 6**  
**Friction Loss in Fire Hose**  
 Loss in PSI per 100 Feet of Hose

SIZE HOSE G.P.M.	LINEN HOSE			BEST RUBER LINED HOSE							
	1 1/2	2	2 1/2	3/4	1	1 1/2	2	2 1/2	3	3 1/2	(2)-2 1/2
10	1.0			13.5	3.5	0.5	.1				
15	2.2			29.0	7.2	1.0	0.3				
20	3.6			50.0	12.3	1.7	0.4				
25	5.5			75.0	18.5	2.6	0.6				
30	8.0	1.9		105.0	26.0	3.6	0.9				
40	13.0	3.2		180.0	44.0	6.1	1.5				
50	20.0	4.9	1.6		67.0	9.3	2.3				
60	28.0	7.0	2.2		96.0	13.5	3.3				
70	37.0	9.0	3.1		131.0	17.0	4.3				
80	47.0	11.5	3.8		171.0	23.0	5.6				
90	59.0	14.5	5.0		217.0	29.0	7.0				
100	72.0	17.5	5.9		268.0	33.0	8.4				
120		25.0	8.3		386.0	47.0	11.7				
140		34.0	11.0			62.0	16.0	5.2	2.0	0.9	1.4
160		43.0	14.0			78.0	20.0	6.6	2.6	1.2	1.9
180		53.0	17.7			97.0	25.0	8.3	3.2	1.5	2.3
200		63.0	21.5			121.0	30.6	10.1	3.9	1.8	2.8
220						146.0		12.0	4.6	2.1	3.3
240						173.0		14.1	5.4	2.5	3.9
260						204.0		16.4	6.3	2.9	4.5
280						237.0		18.7	7.2	3.3	5.2
300						272.0		21.2	8.2	3.7	5.9
320								23.8	9.3	4.2	6.6
340								26.9	10.5	4.7	7.4
360								30.0	11.5	5.2	8.3
380								33.0	12.8	5.8	9.2
400								36.2	14.1	6.3	10.1
425								40.8	15.7	7.0	11.3
450								45.2	17.5	7.9	12.5
475								50.0	19.3	8.7	13.8
500								55.0	21.2	9.5	15.2
525									23.2	10.5	16.6
550									25.2	11.4	18.1
575									27.5	12.4	19.6
600									29.9	13.4	21.2
650									34.5	15.5	24.8
700									39.5	17.7	28.3
750									45.0	20.1	32.2
800									50.5	22.7	36.2
850									56.5	25.4	40.7
900									63.0	28.2	45.2
1000									76.5	34.3	55.0

Losses in rough walled, rubber hose may be 50% higher than values given above.

**TABLE NO. 7**  
**Friction Loss in 15-year-old Steel Pipe**  
 Loss in PSI per 100 Feet of Pipe

PIPE SIZE G.P.M.	1/8	1/4	3/8	1/2	3/4	1	1 1/4	1 1/2	2	2 1/2	3	4	6	8
1	52.0	12.0	2.8	0.9										
2		45.0	10.0	3.2	4.0									
5			55.0	18.0	4.5	1.4	0.4							
10				64.0	16.0	5.0	1.3	0.6						
15				135.0	34.0	11.0	2.7	1.3	0.5					
20					59.0	18.0	4.7	2.2	0.8					
25					89.0	27.0	7.1	3.4	1.2					
30					125.0	39.0	10.0	4.7	1.7	0.6				
35						51.0	13.0	6.3	2.2	0.7				
40						66.0	17.0	8.0	2.9	0.9				
45						82.0	21.0	10.0	3.6	1.2				
50						99.0	26.0	12.0	4.3	1.4	0.6			
60						140.0	38.0	17.0	6.1	2.0	0.8			
70							49.0	23.0	8.0	2.7	1.1			
80							63.0	29.0	10.0	3.4	1.5			
90							78.0	36.0	13.0	4.3	1.8			
100							96.0	44.0	15.0	5.1	2.2	0.5		
125							144.0	66.0	24.0	7.8	3.3	0.8		
150								93.0	33.0	11.0	4.6	1.1		
175								125.0	44.0	15.0	6.1	1.5		
200									56.0	19.0	7.8	1.9		
250									84.0	28.0	12.0	2.9		
300									114.0	40.0	16.0	4.0	0.6	
350										53.0	22.0	5.4	0.8	
400										68.0	28.0	6.9	1.0	
450										84.0	35.0	8.6	1.2	
500										102.0	42.0	10.0	1.4	0.4
600											60.0	15.0	2.1	0.6
800												25.0	3.5	1
1000												37.0	5.2	1.3
1500													11.0	2.7
2000													19.0	4.7
2500													29.0	7.1
3000														10

**TABLE NO. 8**  
**Resistance of Fittings**  
**Equivalent Lengths of Straight Pipe - Feet**

PIPE SIZE	1/2	3/4	1	1 1/4	1 1/2	2	2 1/2	3	4	5	6	8
Gate Valve	0.4	0.6	0.8	1.1	1.4	1.8	2.2	2.8	4.1	5.3	6.7	9.4
Global Valve	3.0	4.5	6.0	8.5	10.5	14.0	17.0	22.0	32.0	42.0	53.0	75.0
Angle Valve	1.4	2.0	2.7	3.8	4.8	6.3	7.9	10.5	14.5	18.5	23.0	33.0
Std. Elbow	1.1	1.5	2.0	2.8	3.5	4.7	5.8	7.5	11.0	14.0	18.0	24.0
45 Elbow	0.6	0.8	1.0	1.4	1.6	2.1	2.5	3.1	4.2	5.2	6.3	8.5
Long Sweep EI Str Run Tee	0.5	0.8	1.0	1.4	1.7	2.3	2.8	3.7	5.3	7.0	9.0	12.5
Std. Tee Thru Side Outlet	2.1	2.9	3.9	5.5	6.9	9.1	11.6	14.8	21.0	27.0	34.0	49.0
Sudden Enlarg or contraction	1.8	2.5	3.2	4.2	5.0	6.5	7.5	9.5	13.0	16.0	19.0	25.0
Entrance to Pipe	1.0	1.3	1.6	2.2	2.6	3.3	3.9	4.9	6.5	8.2	10.0	13.0

**TABLE NO. 9**  
**To Convert Pounds per Square Inch to**  
**Feet Elevation of Water**

**2.308ft head = 1.0 psi**  
**1ft head = .433psi**

Feet	5	10	15	20	25	30	35	40	45	50	60	70	80	90
Pounds	2.2	4.3	6.5	8.7	11	13	15	17	20	22	26	30	35	39
<b>Feet</b>	<b>100</b>	<b>120</b>	<b>130</b>	<b>140</b>	<b>150</b>	<b>160</b>	<b>170</b>	<b>180</b>	<b>190</b>	<b>200</b>	<b>220</b>	<b>240</b>	<b>260</b>	<b>280</b>
<b>Pounds</b>	<b>43</b>	<b>52</b>	<b>56</b>	<b>61</b>	<b>65</b>	<b>69</b>	<b>74</b>	<b>78</b>	<b>82</b>	<b>87</b>	<b>95</b>	<b>104</b>	<b>113</b>	<b>121</b>
Feet	300	320	340	360	380	400	425	450	475	500	525	550	600	700
Pounds	130	139	147	156	165	173	184	195	206	217	227	238	260	303

**Table NO. 10**  
**American National Fire Hose Connection Screw Thread - NH**

Size of Hose	4-Mar	1	1 1/2	2 1/2	3	3 1/2	4	4 1/2	5	6	8
Thr'ds per inch	8	8	9	7.5	6	6	4	4	4	4	4
Thread Designation	0.75-8 NH	1-8 NH	1.5-9 NH	2.5-7.5 NH	3-6 NH	3.5-6 NH	4-4 NH	4.5-4 NH	5-4 NH	6-4 NH	8-4 NH
Max. O.D. Male	1.375	1.375	1.99	3.0686	3.6239	4.2439	5.0109	5.7609	6.26	7.025	9.05

Ref. NFPA 1963

Underwriters Nozzle Tip Thread: 2.1875 O.D. - 12 threads per inch.

**IF FURTHER INFORMATION IS NEEDED, CALL W.S. DARLEY & CO. AT**  
**CHIPPEWA FALLS, WI. AT 800-634-7812 or 715-726-2650**

# W.S. DARLEY & CO.

## OPERATING INSTRUCTIONS - ELECTRIC PRIMING PUMP

The Darley electric primer will develop up to 25 in. Hg. in an air tight pumping system.

The Primer is activated by a combination spring return on-off valve and electric switch. Pulling the valve out opens the valve and closes the electrical circuit to start the motor.

Before the pump can be primed, booster line valves, drain valves, cooling line valve, and all other openings into the pump must be closed and absolutely air tight. The discharge side of the pump is sealed by a check valve, therefore the main discharge valves need not be closed.

When operating from draft, suction hose connections must be tight and free of air leaks.

Make certain the suction hose strainer is properly submerged and free of foreign material.

The main pump drive should remain disengaged until priming is complete to prevent possible damage to impeller seal rings by running "dry".

Pull the primer shutoff valve all the way out to start priming and hold open until water discharges from primer pump exhaust port. Push valve all the way in to shut off primer motor and seal tight.



### **CAUTION:** FOR PRIMING UP TO 10' OF LIFT:

If water does not discharge from the primer exhaust within about 30 seconds (45 seconds with 2 – 20' lengths of hose) stop the primer pump, check for air leaks and make sure primer pump is receiving lubricant from its reservoir, if one is present. **MAX PRIMER OPERATION TIME = 90 seconds every 5 minutes. DO NOT EXCEED 90 SECONDS OF PRIMER OPERATION.**



### **CAUTION:** FOR PRIMING 10' OF LIFT AND HIGHER:

If water does not discharge from the primer exhaust within 90 seconds stop the primer pump, check for air leaks and make sure primer pump is receiving lubricant from its reservoir, if one is present. **DO NOT EXCEED 90 SECONDS OF PRIMER OPERATION.**



**CAUTION:** The primer pump and motor will begin to generate heat as soon as operation begins. Extended run times (up to 90 seconds) and repeating priming cycles consecutively or within short time periods may lead to premature failure of the primer pump assembly: such failures include but are not limited to: overheating of the motor, seizure of the rotor, and cracking of primer vanes. To avoid this, after your first priming attempt, thoroughly inspect the pump system for air leaks, check that the primer is

**receiving lubricant from its reservoir if such is present, and resolve the issue before attempting re-prime.**

Engage “Pump” shift to start pumping water.

When pumping from hydrants, the primer is not needed and must be kept closed.

It may be necessary to use the primer momentarily when pumping from a booster tank when the suction head is insufficient to force all the air out of the pump.

## **LUBRICATING SYSTEM - ELECTRIC PRIMING PUMPS WITH FLUID RESERVOIR**

The electric motor rotary van primer pump creates a high vacuum by continuous lubrication of rotor and vanes. Therefore the primer lubricant supply tanks (4 quarts) should be kept full at all times. Recommended primer system lubricant is Darley PRIME GREEN. PRIME GREEN is an environmentally safe, non-toxic, biodegradable lubricant. Its use assures proper primer vane lubricant while minimizing environmental effects.

After the main pump is drained, run the primer motor to drain primer lines and re-lubricate the primer pump.

The vent hole on the lubricant tank cap should be kept open at all times to prevent siphoning lubricant from the tank after the pump is stopped. Do not increase the size of the hole.

Locate the lubricant tank where it may be conveniently inspected and filled.

Should water appear in the lubricant supply tank, the primer valve is leaking. Check and replace valve plug seal o-ring if necessary.

## **ELECTRIC PRIMING PUMPS WITHOUT FLUID RESERVOIR**

The fluidless electric-motor rotary-vane primer pump creates a high vacuum by using a special material for the vanes and an initial factory applied lubricant film. This film must be present in order for the primer to operate properly and to provide maximum life for the primer components.

This film should not wash away completely if the pump is used to pump clean water. If the priming pump is disassembled for any reason, all internal surfaces of the housing and end caps must be cleaned and coated completely with Dow Corning #111 Silicone valve lubricant prior to operating the primer. If a degradation of performance is noticed, performance may be restored by re-applying the film in this manner. It is recommended to service the primer annually to clean and re-apply the silicone film to the inside of the primer housing and end caps. Do not apply grease to the rotor slots, or the sides of the vanes.

After the main pump is drained, run the primer motor to drain primer lines.

AN	DESCRIPTION	PART NO.	QTY.
1	ASSEMBLY - PRIMER, MOTOR	4220105	1
2	BEARING - OILITE, 0.625 ID	1760023	2
3	COUPLING - 844093	2404500	1
4	CTL PRIMER - VACUUM PUMP	020800	1
5	HEAD - CYLINDER INBOARD	200800	1
6	HEAD - CYLINDER, OUTBOARD	200800	1
7	SHCS - 313-18 X 1.00, SST	540610	4
8	WET - SO., 0.19 X 0.62, GR2	3602425	1
9	WET - WOODRUFF, 606	3602200	1
10	MOTOR - PRIMER, 12V	4223400	1
11	NUT - HEL., 313-15, SST	5403024	2
12	O-RING - 3.50 X 3.69 X 0.69	3801101	2
13	OIL SEAL - 0.625 ID X 1.128 OD	3800305	1
14	PLUG - PIPE, 0.250, BR, 50, 10	080204	1
15	STRAP - GROUND, 12V PRIMER	0805116	1
16	WASHER - FLAT, 5/16, STEEL	3403802	2
17	WASHER - LOCK, 0.313 ID	3403502	6

REV.	DESCRIPTION	DATE	BY	CHKD.	APP.
1	REVISED FOR USER				

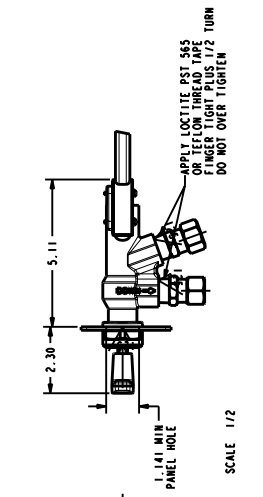
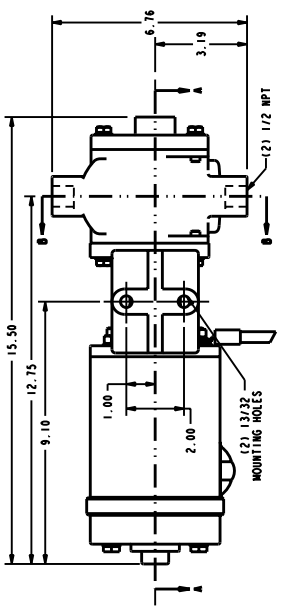
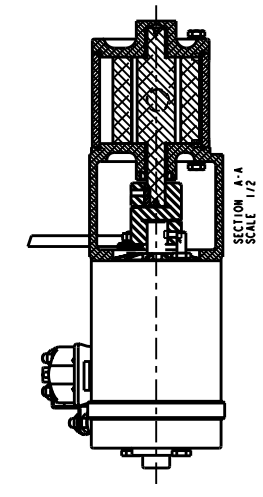
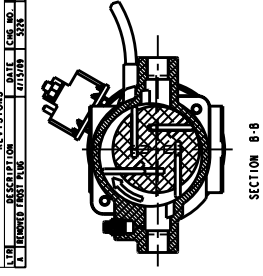

NOTE:  
FOR CROSS SECTION AND EXPLODED VIEW DRAWING  
SEE OVERALL DIMENSIONS & DIMENSIONS OF THIS VALVE WITH  
THIS NEW VERSION. BUSHING 7162500 CAN BE USED TO RETROFIT IT  
TO THE EXISTING PANEL.

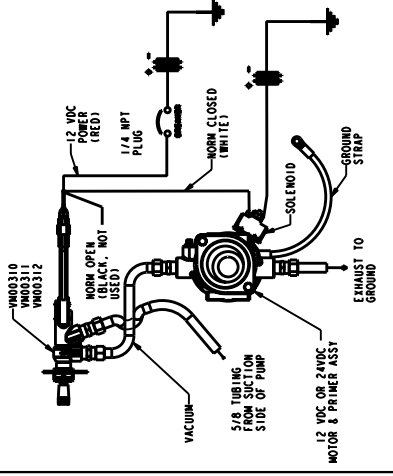
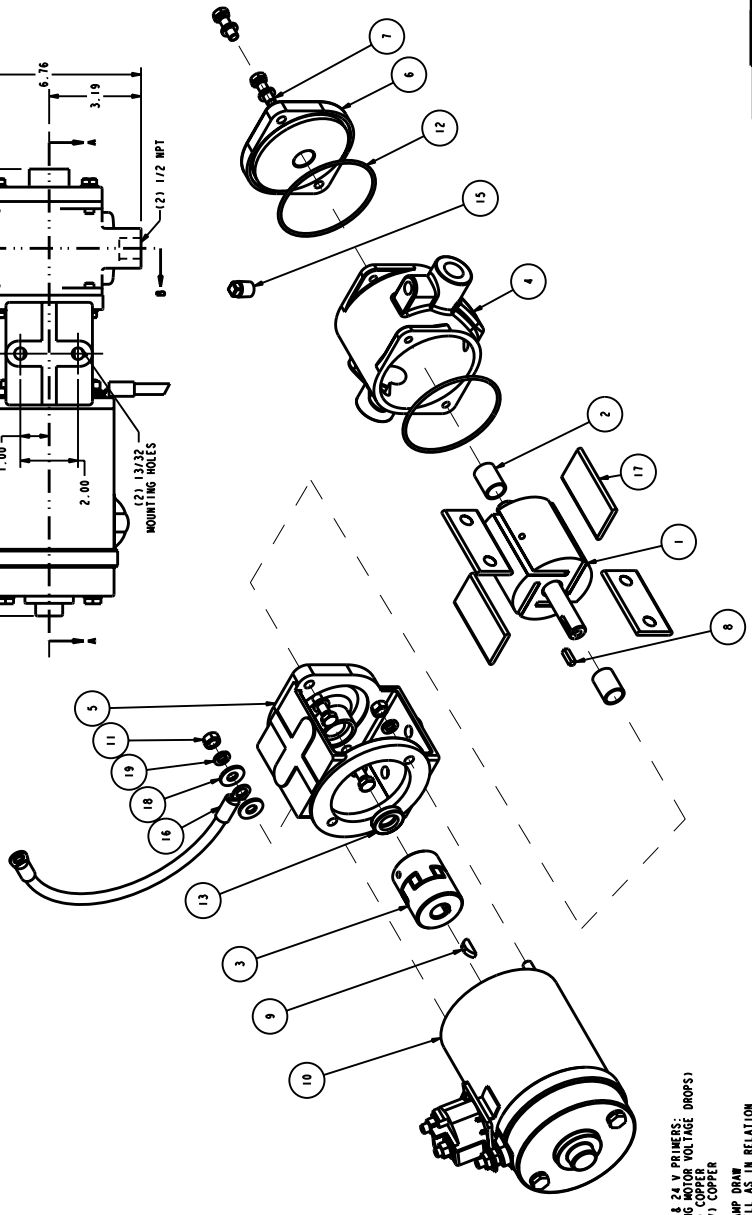

NOTE:  
MOUNT WITH EXHAUST OUTLET DOWN  
TO CLEAN, PAINT FREE GROUNDING SURFACE  
IF SUPPLIED GROUND STRAP IS REMOVED FROM ASSEMBLY, RETAINING CYLINDER HEAD ADAPTER TO 90 IN. L.B.

POSITIVE LEAD WIRE SIZES FOR 12 V & 24 V PRIMERS:  
0 - 10 AMP STANDARD (12V), 0.125 (24V) COPPER  
0 - 10 25' ..... 000 (12V), #2 (24V) COPPER

THESE GAGE WIRES CORRESPOND WITH AMP DRAW REQUIREMENTS FOR EACH WIRE AS WELL AS IN RELATION TO RESISTANCE OVER GIVEN LENGTH.  
12 V = 240 AMP  
24 V = 140 AMP

WEIGHT = 27 LB. (12.1 KG)

REV.	DESCRIPTION	DATE	BY	CHKD.	APP.
1	REVISED FOR USER				

REV.	DESCRIPTION	DATE	BY	CHKD.	APP.
1	REVISED FOR USER				

REV.	DESCRIPTION	DATE	BY	CHKD.	APP.
1	REVISED FOR USER				

REV.	DESCRIPTION	DATE	BY	CHKD.	APP.
1	REVISED FOR USER				

REV.	DESCRIPTION	DATE	BY	CHKD.	APP.
1	REVISED FOR USER				

REV.	DESCRIPTION	DATE	BY	CHKD.	APP.
1	REVISED FOR USER				

REV.	DESCRIPTION	DATE	BY	CHKD.	APP.
1	REVISED FOR USER				

REV.	DESCRIPTION	DATE	BY	CHKD.	APP.
1	REVISED FOR USER				

DVC0207



NO.	DESCRIPTION	PART NO.	QTY.
1	ASSEMBLY - PRIMER, MOTOR	425105	1
2	BEARING - OILITE, 0.625 ID	176023	2
3	COUPLING - 844093	240450	1
4	CYLINDER - VACUUM PUMP	1024800	1
5	HEAD - CYLINDER, IMBOARD	200904	1
6	HEAD - CYLINDER, OUTBOARD	200900	1
7	PISTON - 313-18 X 1.00, SST	5408610	4
8	KEY - SO., 0.19 X 0.62 GR2	3602425	1
9	KEY - WOODRUFF, 608	3602200	1
10	MOTOR - PRIMER, 24V	4225500	1
11	MUT. - MET., 313-15, SST	5403024	2
12	O-RING - 3.50 X 3.69 X 0.09	3601101	2
13	OIL SEAL - 0.625 ID X 1.128 OD	3600905	1
14	TUBE FITTING - STR., .25 X .19	3300021	1
15	STRAP - GROUND, 12V PRIMER	2600516	1
16	WASHER - FLAT, .5716, STEEL	4407640	4
17	WASHER - LOCK, 0.313 ID	3603502	2
18	WASHER - LOCK, 0.313 ID	3603502	2
19	WASHER - LOCK, 0.313 ID	3603502	2

REVISIONS	
NO.	DESCRIPTION
1	REVISED - FIRST ISSUE
2	REVISED - REVISED
3	REVISED - REVISED
4	REVISED - REVISED
5	REVISED - REVISED
6	REVISED - REVISED
7	REVISED - REVISED
8	REVISED - REVISED
9	REVISED - REVISED
10	REVISED - REVISED
11	REVISED - REVISED
12	REVISED - REVISED
13	REVISED - REVISED
14	REVISED - REVISED
15	REVISED - REVISED
16	REVISED - REVISED
17	REVISED - REVISED
18	REVISED - REVISED
19	REVISED - REVISED
20	REVISED - REVISED
21	REVISED - REVISED
22	REVISED - REVISED
23	REVISED - REVISED
24	REVISED - REVISED
25	REVISED - REVISED
26	REVISED - REVISED
27	REVISED - REVISED
28	REVISED - REVISED
29	REVISED - REVISED
30	REVISED - REVISED

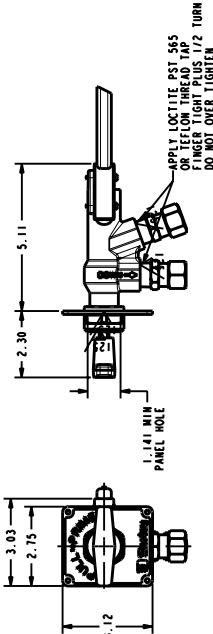
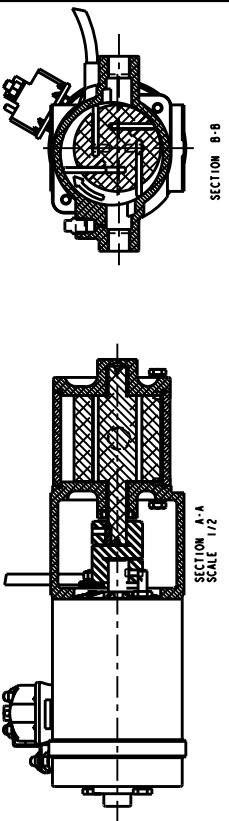

NOTE:  
FOR CROSS SECTION AND EXPLODED VIEW DRAWING  
SEE DRAWING DVC0203  
ALSO, WHEN REPLACING THE OLD VERSION OF THIS VALVE WITH THE NEW VERSION, PART NUMBER 1762300 CAN BE USED TO RETROFIT IT TO THE EXISTING PANEL.

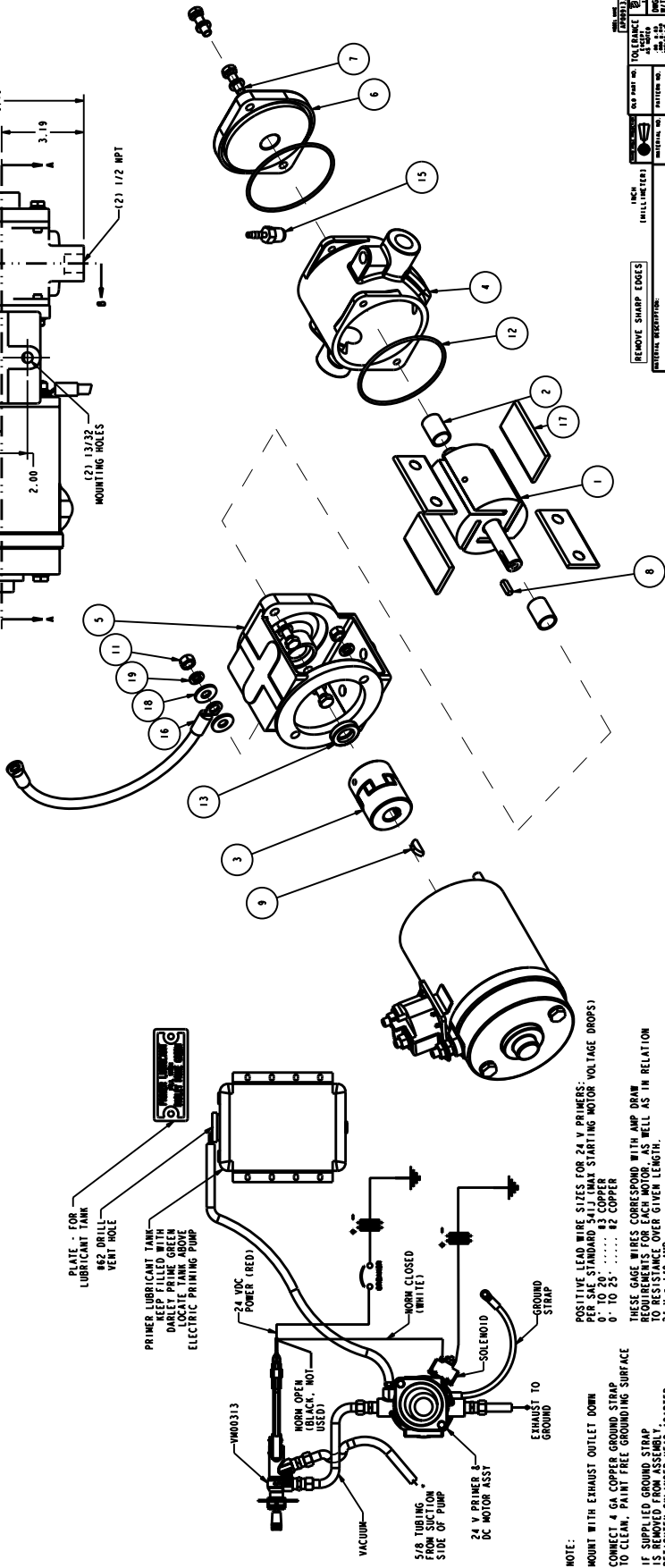

NOTE:  
MOUNT WITH EXHAUST OUTLET DOWN  
CONNECT 4 GA COPPER GROUND STRAP TO CLEAN, PAINT FREE GROUNDING SURFACE  
IF SUPPLIED GROUND STRAP  
RETIGHTEN CYLINDER HEAD ADAPTER  
RETAINING NUTS EQUALLY  
TO 90 IN. LB.

POSITIVE LEAD WIRE SIZES FOR 24 V PRIMERS:  
PER SAE STANDARD 541J (MAX STARTING MOTOR VOLTAGE DROPS)  
0 TO 20' ..... #3 COPPER  
0 TO 25' ..... #2 COPPER

THESE GAGE WIRES CORRESPOND WITH AMP DRAW REQUIREMENTS FOR EACH MOTOR, AS WELL AS IN RELATION TO 24 V = 140 AMP

WEIGHT : 27 LB (12.1 KG)

REVISIONS	
NO.	DESCRIPTION
1	REVISED - FIRST ISSUE
2	REVISED - REVISED
3	REVISED - REVISED
4	REVISED - REVISED
5	REVISED - REVISED
6	REVISED - REVISED
7	REVISED - REVISED
8	REVISED - REVISED
9	REVISED - REVISED
10	REVISED - REVISED
11	REVISED - REVISED
12	REVISED - REVISED
13	REVISED - REVISED
14	REVISED - REVISED
15	REVISED - REVISED
16	REVISED - REVISED
17	REVISED - REVISED
18	REVISED - REVISED
19	REVISED - REVISED
20	REVISED - REVISED
21	REVISED - REVISED
22	REVISED - REVISED
23	REVISED - REVISED
24	REVISED - REVISED
25	REVISED - REVISED
26	REVISED - REVISED
27	REVISED - REVISED
28	REVISED - REVISED
29	REVISED - REVISED
30	REVISED - REVISED

# W.S. DARLEY & CO.

## OPERATING INSTRUCTIONS - ELECTRIC PRIMING PUMP

### PUSH BUTTON ELECTRIC ACTUATED VALVE

The Darley electric primer will develop up to 25 in. Hg. in an air tight pumping system.

The Primer is activated by a push button, 0.8 second cycle time, electric-actuated valve. This valve has three wires: ground (black), +12 or +24 VDC constant power (red), and +12 or +24 VDC energizing power (white). The valve has two internal micro-switches that cut the power to the valve when it is either fully closed or fully open. The push button is a simple SPST switch, that bypasses the red (constant power) wire with the white wire and energizes the valve to the open position when it is pushed; and cuts power to the white wire and resumes power to the red wire, closing the valve when it is released. When the button is pushed, the circuit for the primer motor is also completed, priming will begin instantaneously, and likewise when the button is released, the primer motor will shut off instantaneously.

Before the pump can be primed, booster line valves, drain valves, cooling line valve, and all other openings into the pump must be closed and absolutely air tight. The discharge side of the pump is sealed by a check valve; therefore the main discharge valves need not be closed.

When operating from draft, suction hose connections must be tight and free of air leaks.

Make certain the suction hose strainer is properly submerged and free of foreign material.

The main pump drive should remain disengaged until priming is complete to prevent possible damage to impeller seal rings by running "dry".

Push the primer/valve activation button, located on your control panel, and hold until water discharges from primer pump exhaust port.

If water does not discharge from primer exhaust within about 30 seconds (45 seconds with 2-20' lengths) stop primer pump, check for air leaks and make sure primer pump is receiving lubricant from its reservoir.

**NOTE: Do not run the primer for more than one minute; it will burn up the motor, if prime is not reached within one minute, repeat the steps above.**

Engage "Pump" shift to start pumping water.

When pumping from hydrants, the primer is not needed and must be kept closed.

It may be necessary to use the primer momentarily when pumping from a booster tank when the suction head is insufficient to force all the air out of the pump.

### LUBRICATING SYSTEM - ELECTRIC PRIMING PUMPS WITH FLUID RESERVOIR

The electric motor rotary van primer pump creates a high vacuum by continuous lubrication of rotor and vanes. Therefore the primer lubricant supply tanks (4 quarts) should be kept full at all times. Recommended primer system lubricant is Darley PRIME GREEN. PRIME GREEN is an environmentally safe, non-toxic, biodegradable lubricant. Its use assures proper primer vane lubricant while minimizing environmental effects.

After the main pump is drained, run the primer motor to drain primer lines and re-lubricate the primer pump.

The vent hole on the lubricant tank cap should be kept open at all times to prevent siphoning lubricant from the tank after the pump is stopped. Do not increase the size of the hole.

Locate the lubricant tank where it may be conveniently inspected and filled.

Should water appear in the lubricant supply tank, the primer valve is leaking. Check and replace valve plug seal o-ring if necessary.

## **ELECTRIC PRIMING PUMPS WITHOUT FLUID RESERVOIR**

The fluidless electric-motor rotary-vane primer pump creates a high vacuum by using a special material for the vanes and an initial factory applied lubricant film. This film must be present in order for the primer to operate properly and to provide maximum life for the primer components.

This film will not wash away completely if the pump is used to pump water. If the priming pump is disassembled for any reason, all internal surfaces of the housing and end caps must be coated completely with Dow Corning #111 Silicone valve lubricant prior to operating the primer. If after several years, a degradation of performance is noticed, performance may be restored by re-applying the film in this manner.

After the main pump is drained, run the primer motor to drain primer lines.

REVISIONS			
LTR	DESCRIPTION	DATE	CHG NO. APPR'D

SUPPLIED BY KZCO

White: Switched 12 VDC (+) = Relay Energized "OPEN"  
 Black: Constant 12 VDC (-)  
 Red: Constant 12 VDC (+)

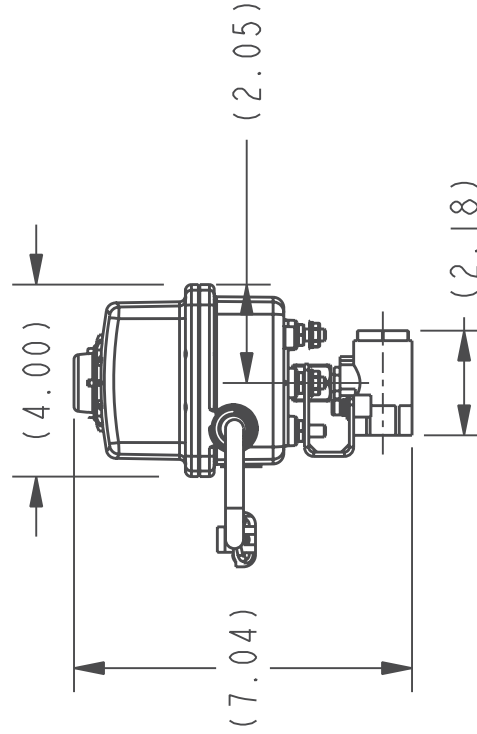
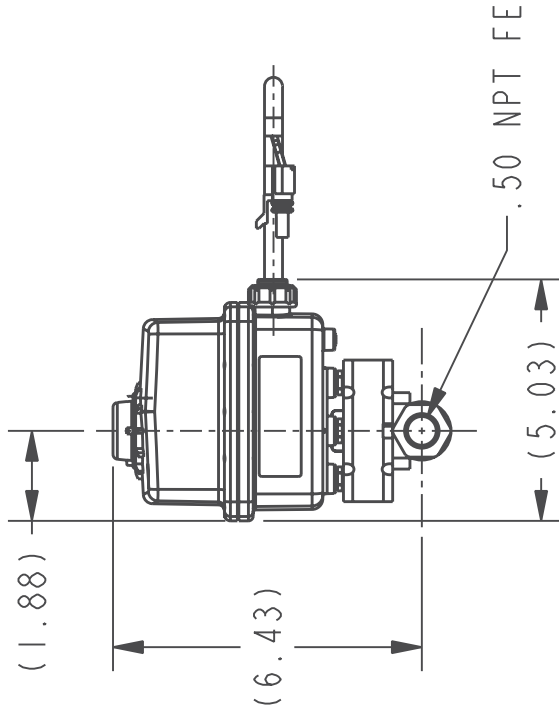
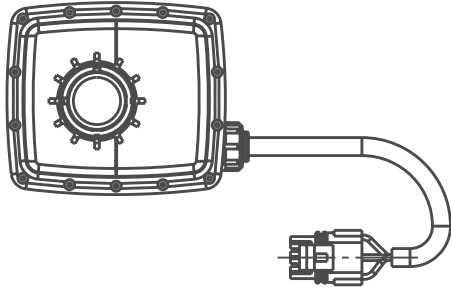
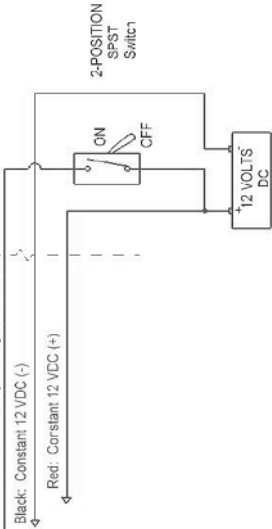

MODEL NAME 5209401 MDL CREATED 11/13/08 SHEET 1/2 A

**W.S. Darley & Co.**  
 ITASCA, IL - CHIPPEWA FALLS, WI

TOLERANCE EXCEPT AS NOTED  
 .00 ±.03  
 .000 ±.010  
 ANGLES ±1°

VALVE - ACTUATED, 12VDC, .50NPT FE  
 KZCO 84D23-10D20-PO1

THIRD ANGLE PROJECTION

OLD PART NO.  
 MATERIAL NO.  
 PATTERN NO.

DO NOT SCALE PRINT

REMOVE SHARP EDGES

MATERIAL DESCRIPTION: KZCO 84D23-10D20-PO1

ALL DIMENSIONS IN INCHES UNLESS NOTED  
 THIS DESIGN IS THE PROPERTY OF W.S. DARLEY AND CO. - UNAUTHORIZED REPRODUCTION IS PROHIBITED

DATE 13-Nov-08  
 SCALE 1/4

**5209401**

REVISED -24	REVISIONS 7/15/2008 9:41:57 AM	REVISIONS BY dsw/rlm	
----------------	-----------------------------------	----------------------------	--

ACTUATOR LABEL  
MA200 LABEL DESCRIPTION  
ACTUATOR, EH3 12/24 VDC

RED MOTOR LEAD  
TO RED DOT

DIP SW 4 ON

**INPUT/OUTPUT POWER - 120V VDC**  
 1 - BLACK - POWER (-) NEGATIVE  
 2 - RED - POWER (+) POSITIVE  
 3 - WHITE - SIGNAL (+) POSITIVE TO OPEN  
 4 - -

**PROGRAM NOTE**

MA200 SET DATA  
 CONTROL INPUT = 1  
 FEEDBACK = 0  
 OPERATION = 0  
 MOTOR = M2  
 SPEED CT = 0.8  
 ZEROSET = 135  
 RANGE TOLERANCE = 1  
 ROTATION = CCW  
 ACTUATOR RANGE = 0.00/0.00  
 DESIGN VOLTAGE = E  
 DIP SW = 3  
 LABEL = K200  
 OPTIONS = 0  
 PLUS TYPE = P  
 TEST PLUG =

**SCALE .500**

**STANDARD MATERIALS**  
 ALL DIMENSIONS IN INCHES UNLESS NOTED OTHERWISE

TOP PLUG - 2017 PM  
 2017  
 SLIP OFF BUSH - 2017  
 2017

LENGTH: 21  
 WIDTH: 21  
 HEIGHT: 21  
 MOUNTING HOLE DIA: 0.125  
 MOUNTING HOLE PITCH: 0.125

QTY	PART NUMBER	DESCRIPTION	MATERIAL
21	EH-502	LABEL, EH ACTUATOR, 2.8" X 1", THERMAL TRANSFER, WHITE	NO MATERIAL
20	800019	HARNESSES, BMA 357, WY9122.5"	POLYPROPYLENE TAIC 20
19	EH3-15-Y	FLAG, YELLOW	
18	309-0029	PCB ASSY, EH3 LT SOLID STATE 12 VDC	NO MATERIAL
17	100-001	GEAR MOTOR, M2 18 RPM/CLON	STAINLESS STEEL TYPE 303
16	03X-22	NUT, HEX HEAD, SEPARATED FLANGE, .250-20 UNC-2B	STAINLESS STEEL TYPE 303
15	EH3-136	STUD, 1/4-20 X 1/2 MTG	STAINLESS STEEL TYPE 303
14	EH-104	RETAINER, PUSH ON 5/16" SHAFT	NO MATERIAL
13	494-0109	CAM ASSY, EXTD LOBE FOR EH3 E-OMP	SILICONE RED, 75 DUROMETER
12	EH-502	LABEL, EH ACTUATOR, 2.8" X 1", THERMAL TRANSFER, WHITE	POLYCARBONATE
11	EH-130	O-RING, DOME	STAINLESS STEEL TYPE 16-8
10	EH3-114	DOME CLEAR	NYLON DPC BK/SHL BLACK
9	EHPT-1103	SCREW PAN PHILLIPS, HIGH-LOW, 5-20 X .502	STAINLESS STEEL TYPE 16-8
8	EH3-1001-N	LID, CASE, EH3, DOME	STAINLESS STEEL TYPE 16-8
7	EH3-100	SCREW, 8-32 X 1.25 PPHAS SS	STAINLESS STEEL TYPE 16-8
6	EH-157	SCREW, 8-18 X .987 158 PPH SS	SILICONE RED, 75 DUROMETER
5	EH3-1030	O-RING, EH3, CASE LD, # 120	FLUOROCARBON (BLACK), 75 DUROMETER
4	EH-130	O-RING, 40/06, PRESSURE TEST PORT	FLUOROCARBON (BLACK), 75 DUROMETER
3	EHPT-540	O-RING, #112, MOTOR SHAFT, VITON	NYLON DPC BK/SHL BLACK
2	EH3-1003H	LOWER CASE - EH3 INTERNAL MTG	
1	408-0012	CASE KIT, EH3 IM DOME NYLON MO MTR	MATERIAL



DATE: 2008-05-23	SCALE: .500	REV: B
DESIGNED: L. EPOCHAMP	DRAWN: W. FIEDICE	
APPROVED: A. KORTAS		
PART NO: 100004-P01	REV: -24	REV: 1 OF 1

REVISIONS

LTR	DESCRIPTION	DATE	CHG NO.	APPR'D

**60AD WIRING**  
Standard On/Off applications, SPST Switch  
24 VDC

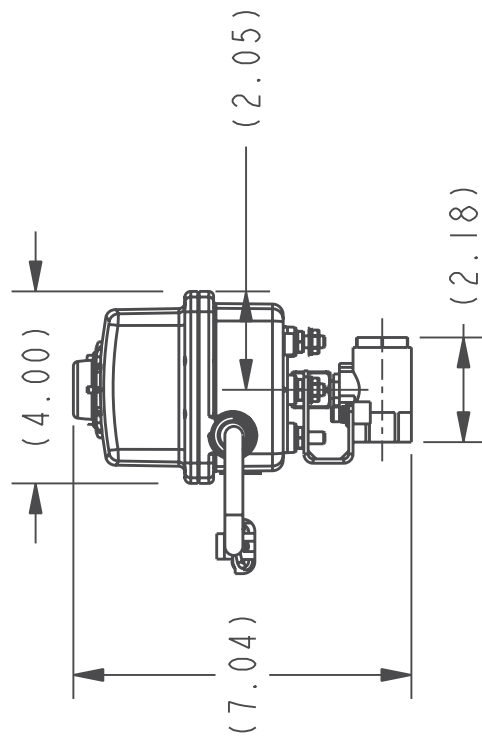
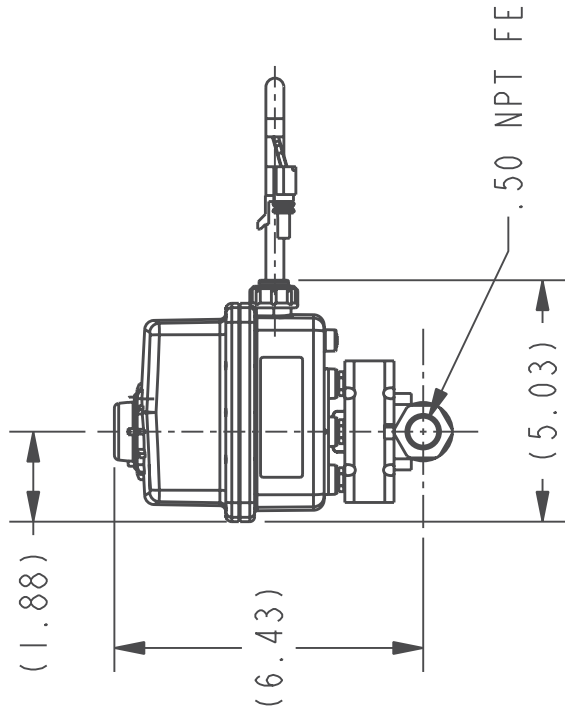
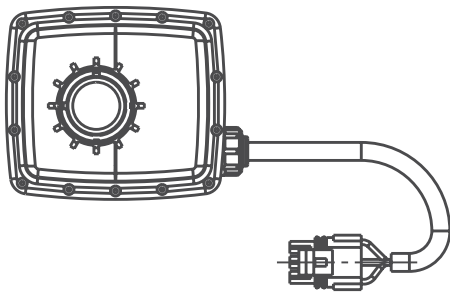
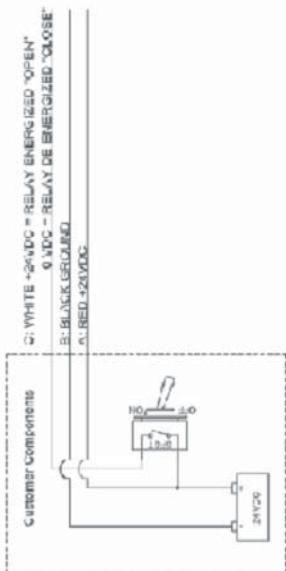

**REMOVE SHARP EDGES**

INCH  
[ MILLIMETER ]



OLD PART NO.

PATTERN NO.

MATERIAL DESCRIPTION:  
KZCO 84D23-60AD-M

THIS DESIGN IS THE PROPERTY OF  
W.S. DARLEY AND CO. - UNAUTHORIZED  
REPRODUCTION IS PROHIBITED

ALL DIMENSIONS IN  
INCHES UNLESS NOTED

DO NOT SCALE PRINT

MODEL NAME 5209402 MDL CREATED 11/13/08 SHEET 1/3 A

**W.S. Darley & Co.**  
ITASCA, IL - CHIPPEWA FALLS, WI

VALVE - ACTUATED, 24VDC, .50NPT FE  
KZCO 84D23-60AD-M

DATE 13-Nov-08  
SCALE 1/4

**5209402**

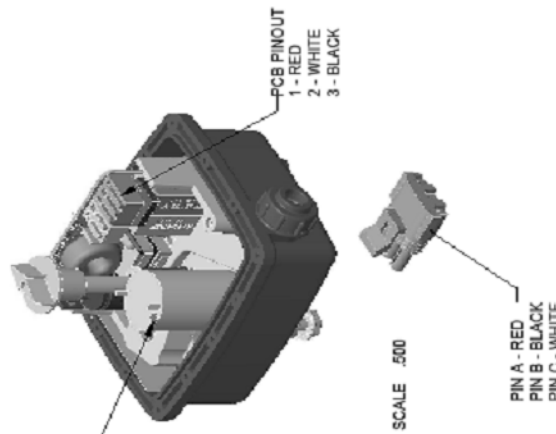

MAS80 SET DATA  
 CONTROL INPUT = 1  
 FEEDBACK = 0  
 OPERATION = 0  
 MOTOR = M  
 SPEED CT = 0.8  
 ZEROSET = 135  
 RANGE TOLERANCE = 1  
 ROTATION = CC081  
 ACTUATOR RANGE = 0.0010.00  
 DESIGN VOLTAGE = D  
 DIP SX =  
 LABEL = KZCO  
 OPTIONS = 0  
 PLUG TYPE =  
 TEST PLUG =

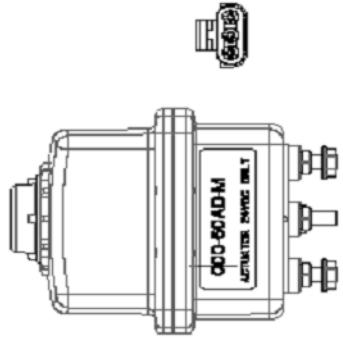
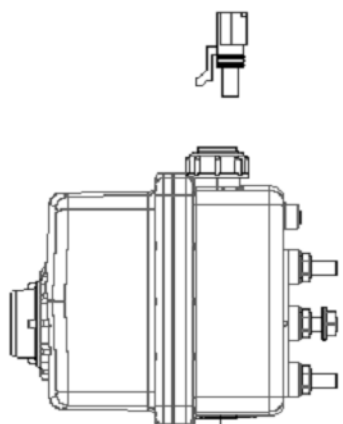

**KZCO inc.**  
 2180 KZ PARKWAY  
 GREENWOOD, NE 68308 USA  
 TEL: 402.294.2020  
 FAX: 402.294.2022

DATE: 2007-04-10  
 DESIGNED: L. ERDKAMP  
 DRAWN: W. FEDDE  
 APPROVED: A. KOTTAS

TITLE: ACTUATOR, EH3, .8S @24VDC  
 REF:  
 PART NO: 000-60AD-M  
 DRAWING NO: 000-60AD-M

REVISION: 001  
 SHEET: 1 OF 1

STANDARD TOLERANCES - ALL DIMENSIONS IN UNLESS SHOWN:	DATE: 2007-04-10
TOTAL FINISH: .005 FIM	DESIGNED: L. ERDKAMP
CHAMFER: .015 X 45°	DRAWN: W. FEDDE
SURFACE FINISH: 12.5 μIN	APPROVED: A. KOTTAS
XX.1	SCALE: .500
XX.2	SIZE: B
XX.3	MATERIAL:
XX.4	
XX.5	
XX.6	
XX.7	
XX.8	
XX.9	
XX.10	
XX.11	
XX.12	
XX.13	
XX.14	
XX.15	
XX.16	
XX.17	
XX.18	
XX.19	
XX.20	
XX.21	
XX.22	
XX.23	
XX.24	
XX.25	
XX.26	
XX.27	
XX.28	
XX.29	
XX.30	
XX.31	
XX.32	
XX.33	
XX.34	
XX.35	
XX.36	
XX.37	
XX.38	
XX.39	
XX.40	
XX.41	
XX.42	
XX.43	
XX.44	
XX.45	
XX.46	
XX.47	
XX.48	
XX.49	
XX.50	

QTY	PART NUMBER	DESCRIPTION	MATERIAL	NO. MATERIAL
1	EH-502	LABEL, EH ACTUATOR, 2.5" X 1", THERMAL TRANSFER, WHITE		
2	QX-222	NUT, HEX HEAD, SERRATED FLANGE, .250-28 UNC-2B	STAINLESS STEEL, TYPE 303	
4	EH3-135	STUD, 1/4-20 X 1/2 MTG	STAINLESS STEEL, TYPE 303	
5	800018	HARNES, 60A, 3ST, WPST, 22.5"		
4	EH3-115-Y	FLAG, YELLOW	POLYPROPYLENE, TALC, 20	
3	800468	PCB ASSY, EH3 24VDC 60AD/60DF		
2	EH3-110	GEAR MOTOR, EH3 SERIES M1 18 RPM @ 12VDC		
1	488-0005	CASE KIT, EH3 IM DOME NYLON M1 & N1 MTR		

REVISION	REVISION DATE	REVISION BY
-6+	8/12/2008 9:18:50 AM	bgotschal

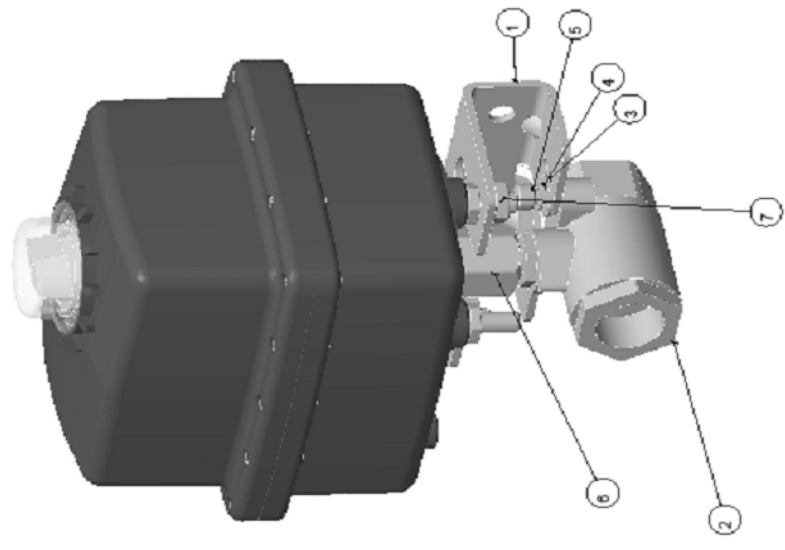
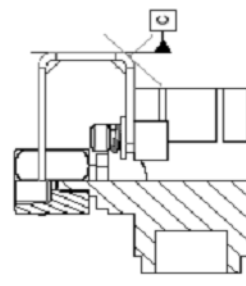
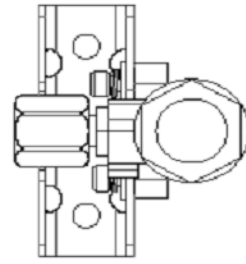
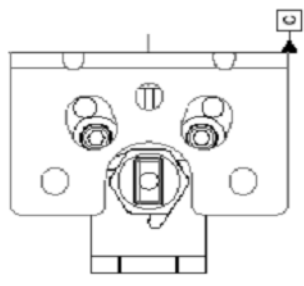

ACTUATOR SHOWN IS REPRESENTATIVE USED ONLY TO SHOW PROPER ORIENTATION TO VALVE.

DET	QTY	PART NUMBER	DESCRIPTION	MATERIAL
7	3	QK-222	NUT, HEX HEAD, SERRATED FLANGE, .250-20 UNC-2B	STAINLESS STEEL TYPE 303
6	1	EH-146	COUPLER, 1/4" ~ 1/2" APOLLO	STAINLESS STEEL TYPE 316
5	2	EH-158	SCREW, #10-24 X 3/8" SS SOCKET HEAD	STAINLESS STEEL TYPE 303 OR 316
4	2	EHPT-105	WASHER, LOCK, .197 ID X .334 OD X .047 T	STAINLESS STEEL TYPE 316
3	2	EHPT-110	WASHER, FLAT, #10 18-8 SS	STAINLESS STEEL TYPE 316
2	1	EH3-54D	VALVE, 1/2" 2-WAY APOLLO 70-03-01 BRONZE BALL VALVE	BRONZE
1	1	EH3-174	BRACKET, MOUNTING EH3 SERIES	STAINLESS STEEL TYPE 304

DESIGNED BY: LERDKAMP	DATE: 2007-08-08
DRAWN BY: C. HOWARD	DESIGNED BY: LERDKAMP
APPROVED BY: LERDKAMP	SCALE: .750
PART NO: 84D23	SIZE: B
DRAWING NO: 84D23	MATERIAL: AS NOTED

STANDARD TOLERANCES - ALL DIMENSIONS IN INCHES UNLESS SHOWN OTHERWISE
TOTAL FINISH: .005 IN
CORNER BREAK: .015 IN
SURFACE FINISH: 125 IN
MAX. SURF. AREA: .0005 IN <sup>2</sup>
DESIGN: .005 IN
MATERIAL: 303 SS
SURF. AREA: 142.871 SQ IN
VOLUME: 12.142 CU IN

DATE: 2007-08-08	DESIGNED BY: LERDKAMP
DRAWN BY: C. HOWARD	APPROVED BY: LERDKAMP
SCALE: .750	SIZE: B
MATERIAL: AS NOTED	

  

2080 ICE PARWAY GREENHAWK, NE 83388 USA PHONE: 714.824.1217 FAX: 714.824.1212	
TITLE: VALVE KIT, EH3 OFFSET MTG 1/2" 2-PC BRZ	
REF:	
PART NO: 84D23	
DRAWING NO: 84D23	



REV.	DESCRIPTION	DATE	CHK. NO.	APP. NO.

NO.	DESCRIPTION	PART NO.	QTY.
1	ASSEMBLY - PRIMER, ROTOR	4420105	1
2	BEARING - OILITE, 0.626 ID	1760023	2
3	COUPLING - #44093	2404500	1
4	CYLINDER - VACUUM PUMP	1020600	1
5	HEAD - CYLINDER INBOARD	2808904	1
6	HEAD - CYLINDER OUTBOARD	2808800	1
7	WCS - 3/13" ID x 1.00" SST	5400510	4
8	HEAT - .50" x 0.19 x 0.82 BRZ.	3602325	1
9	HEAT - WOODRUFF, 606	3602200	1
10	MOTOR - PRIMER, 12V	4223400	1
11	NUT - HEX., 3/13" x 15, SST	5403824	2
12	O-RING - 3.50 x 3.69 x 0.09	3601101	2
13	OIL SEAL - 0.625 ID x 1.128 OD	3600505	1
14	PLUG - 0.75" FREEZE	4402500	1
15	PIPE - PIPE, 0.750, BR SO HD	1080504	1
16	STRAP - GROUND, 12V PRIMER	2600516	1
17	WASHER - ROTOR, ELEC PRIMER	4407601	4
18	WASHER - FLAT, 3/16, STEEL	3603802	2
19	WASHER - LOCK, 0.313 ID	3603302	6

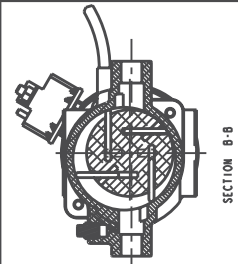
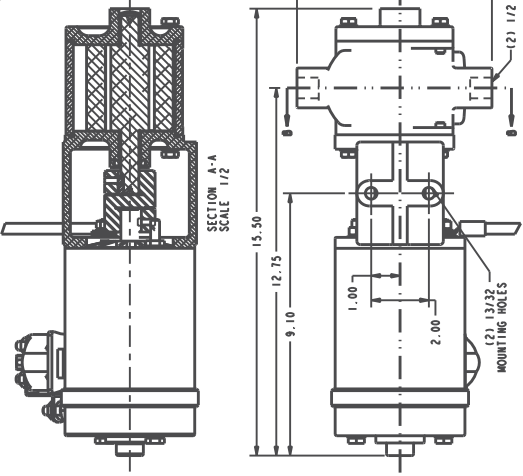
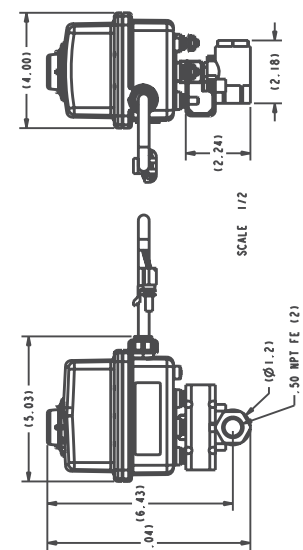

5209401 - RZCO VALVE - ACTUATED.  
12 VDC, .50NPT FE  
RZCO MOL 86023-10020-POI

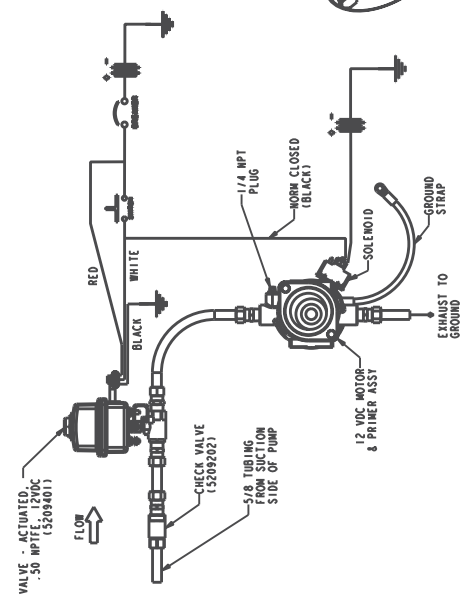
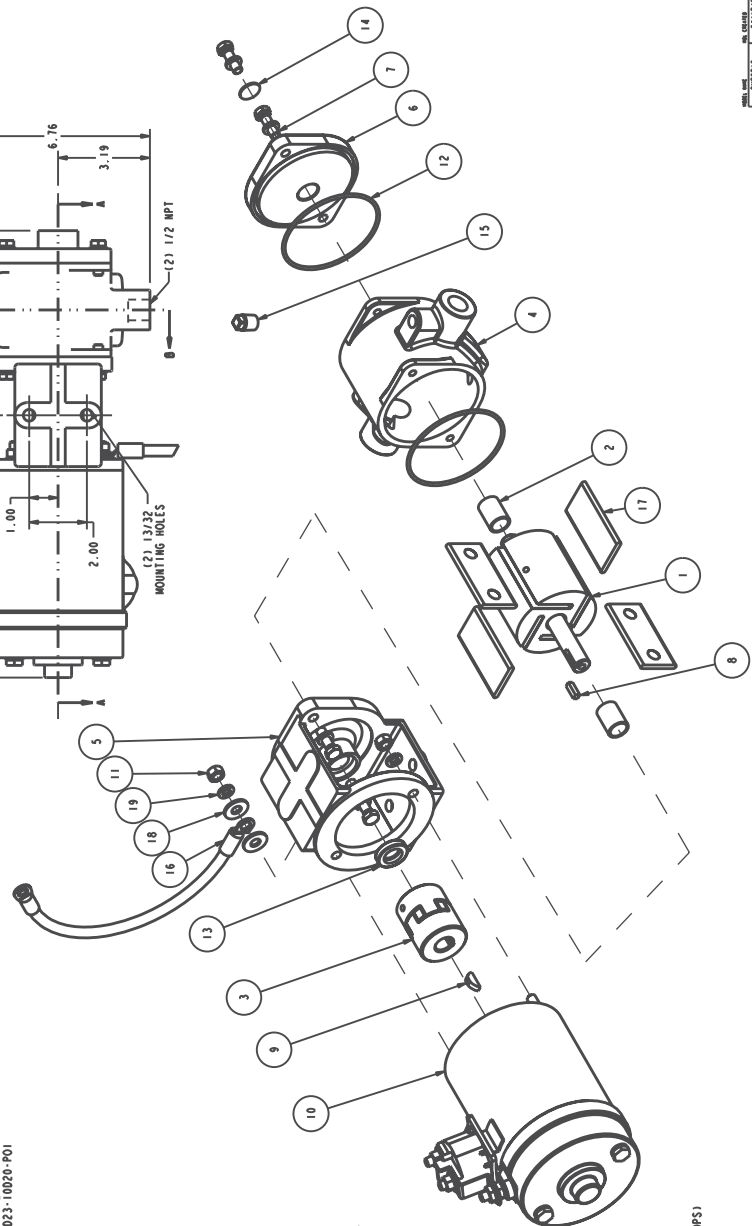

NOTE:  
MOUNT WITH EXHAUST OUTLET DOWN  
CONNECT 4 GA COPPER GROUND STRAP TO CLEAN, PAINT FREE GROUNDING SURFACE IF SUPPLIED GROUND STRAP IS REMOVED FROM ASSEMBLY. RETIGHTEN CYLINDER HEAD ADAPTER REMAINING NUTS EQUALLY TO 90 IN.LB.

POSITIVE LEAD WIRE SIZES FOR 12 V PRIMER:  
PER SAE STANDARD S-1112 (MAX STARTING MOTOR VOLTAGE DROPS)  
0 - TO 25' ..... 800 (12V)  
0 - TO 25' ..... 800 (12V)

THESE GAUGE WIRES CORRESPOND WITH AMP DRAW TO RESISTANCE OVER GIVEN LENGTH.  
12 V : 240 AMP

WEIGHT - 27 LB (12.1 KG)

REV.	DESCRIPTION	DATE	CHK. NO.	APP. NO.

SCALE	1/2"
SCALE	1/2"
SCALE	1/2"
SCALE	1/2"

OLD PART NO.	10L GRABER
NEW PART NO.	47500
DATE	12-29-88
DESIGNED BY	W. J. ...
CHECKED BY	...
DATE	12-29-88
SCALE	1/2"

REMOVE SHARP EDGES  
ALL DIMENSIONS IN INCH UNLESS OTHERWISE SPECIFIED  
DO NOT SCALE PRINT

THIS DRAWING IS THE PROPERTY OF  
W. J. ...  
ALL RIGHTS RESERVED

DATE 12-29-88  
SCALE 1/2"

W. J. ...  
DATE 12-29-88  
SCALE 1/2"

W. J. ...  
DATE 12-29-88  
SCALE 1/2"

W. J. ...  
DATE 12-29-88  
SCALE 1/2"

W. J. ...  
DATE 12-29-88  
SCALE 1/2"

NO.	DESCRIPTION	PART NO.	QTY.
1	ASSEMBLY - PRIMER, ROTOR	4420105	1
2	BEARING - OILITE, 0.626 ID	1760023	2
3	COUPLING - #44093	2404500	1
4	CYLINDER - VACUUM PUMP	1020000	1
5	HEAD - CYLINDER, INBOARD	2808904	1
6	HEAD - CYLINDER, OUTBOARD	2808900	1
7	WASHER - 3/16 X 1.00, SST	5400510	4
8	WASHER - 5/16 X 0.82 GR2	3602425	1
9	WASHER - WOODRUFF, 606	3602500	1
10	WASHER - PRIMER, 24V	4423500	1
11	WASHER - HEX., 3/16 X 1.00, SST	5403024	2
12	O-RING - 3.50 X 3.69 X 0.09	3601101	2
13	OIL SEAL - 0.625 ID X 1.128 OD	3600505	1
14	PLUG - 0.75" FREEZE	4402500	1
15	PLUG - PIPE, 0.250, BR 50 HD	1080504	1
16	STRAP - GROUND, 12V PRIMER	2600516	1
17	WASHER - ROTOR, ELEC PRIMER	4407601	4
18	WASHER - FLAT, 5/16, STEEL	3603802	2
19	WASHER - LOCK, 0.313 ID	3603502	6

REVISIONS

DATE	DESCRIPTION	BY	CHKD	APP'D

5209402 - RZCO VALVE - ACTUATED,  
 24 VDC, .50NPT FE  
 RZCO MDL 864023-60AD-M

NOTE:

1. MOUNT WITH EXHAUST OUTLET DOWN

2. CONNECT 4 GA COPPER GROUND STRAP TO CLEAN, PAINT FREE GROUNDING SURFACE

3. IF SUPPLIED GROUND STRAP IS REMOVED FROM ASSEMBLY, RETIGHTEN CYLINDER HEAD ADAPTER REMAINING NUTS EQUALLY TO 90 IN.LB.

4. POSITIVE LEAD WIRE SIZES FOR 24 V PRIMER:  
 PER SAE STANDARD S410 MAX STARTING MOTOR VOLTAGE DROPS)  
 0' TO 25' ..... 42 COPPER (24V)  
 25' TO 50' ..... 42 COPPER (24V)

5. THESE GAGE WIRES CORRESPOND WITH AMP DRAW TO RESISTANCE OVER GIVEN LENGTH.  
 24 V = 140 AMP

REMOVE SHARP EDGES

INCH (MILLIMETERS)

DATE: 10-APR-08

SCALE: 1/2

DO NOT SCALE PRINT

REV. 0

DATE: 12-02-08

1200617

DVC0211



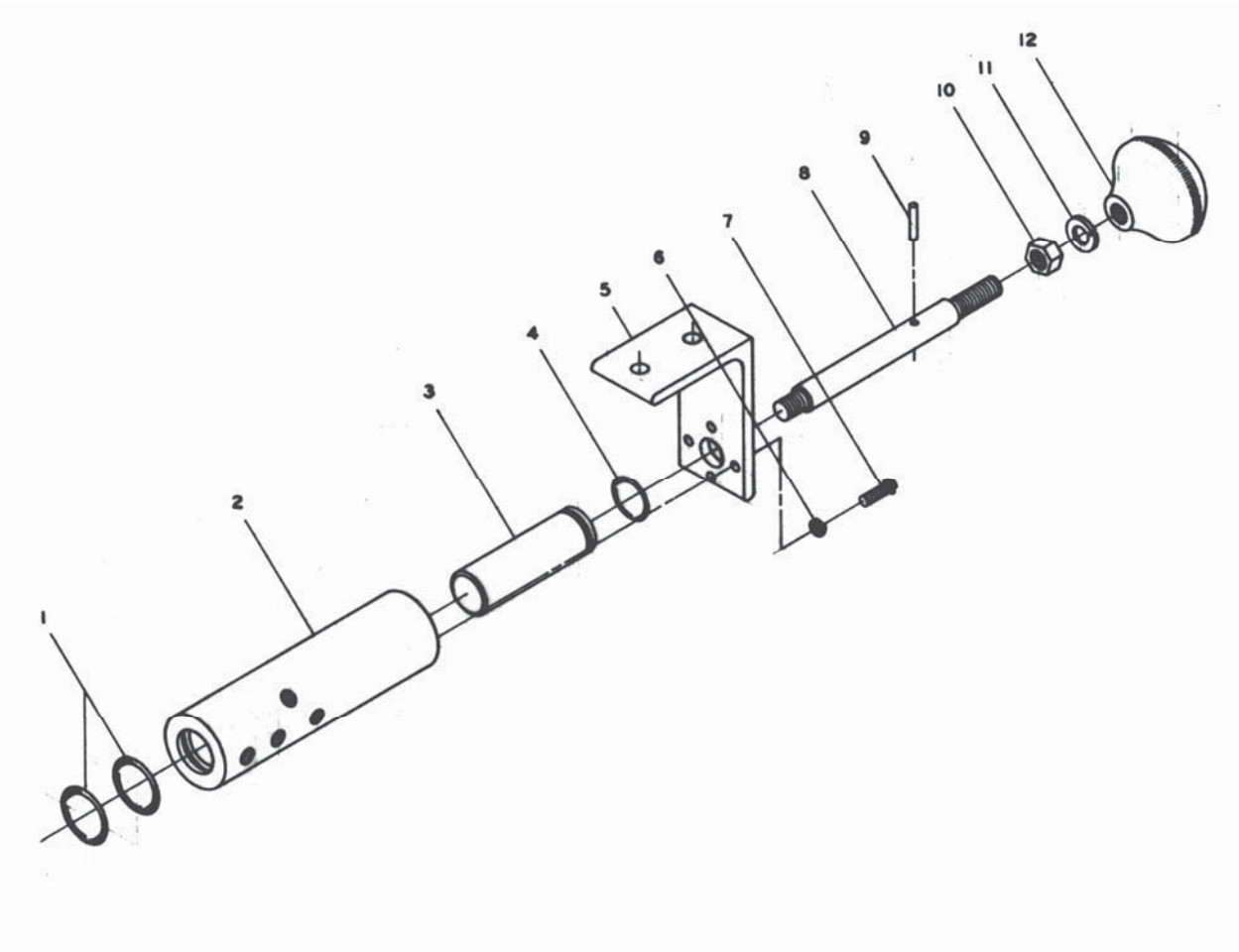

## PARTS LIST FOR MULTIPLE DRAIN VALVE

### DRAWING NO. DGC0112

Rep. No.	Name of Part	Qty	Rep. No.	Name of Part	Qty
1	O-ring – Body	2	7	Round Head Cap Screw	4
2	Drain Valve Body	1	8	Drain Valve Stem	1
3	Drain Valve Plug	1	9	Pin	1
4	O-ring – Plug	1	10	Hex Nut	1
5	Drain Valve Mounting Bracket	1	11	Lock Washer	1
6	Lock Washer	4	12	Knob	1

LT#	DESCRIPTION	DATE	CHG. NO.	APPR'D
A	ADDED ASSEMBLY NOTE	29SEP2005	2005-287	EWH
B	WAS 4031300	03APR2006	2006-110	SMS
C	WAS RETAINER RING 3600435	28NOV2007	2007-456	SMS
D	WAS 5400003	30JAN2008	2008-042	SMS
E	ADDED 5403027	15FEB2008	2008-061	SMS

NO.	DESCRIPTION	PART NO.	QTY.
1	BEARING - OILITE, 0.500 ID	1760024	1
2	BODY - MULTI DRAIN VALVE	5329401	1
3	BRACKET - MULTI DRAIN VALVE	4031300	1
4	CAP - MULTI DRAIN VALVE	5323802	1
5	DECAL - DRAIN VALVE	1963200	1
6	GREASE ZERK - .25-28	4403200	1
7	HANDWHEEL	3001800	1
8	HHCS - .250-20 x 0.88, 18-8	5400658	2
9	O-RING - 0.38 x 0.50 x 0.06	3601000	1
10	O-RING - 1.62 x 2.00 x 0.19	3601305	1
11	RHMS - NO.10-24 x 0.50, SST	5402046	3
12	RING - RETAINER, 68011	3600435	1
13	SEAL - MULTI DRAIN VALVE	3802602	1
14	SSS - 1/4-20 x 0.38, SST	5402603	1
15	STEM - MULTIPLE DRAIN VALVE	5241302	1
16	WASHER - .52 X 1.12 X .12	3603319	1
17	NUT - JAM, .500-20, 18-8 SST	5403219	1
18	NUT - HEX, .250-20, 18-8 SST	5403027	2

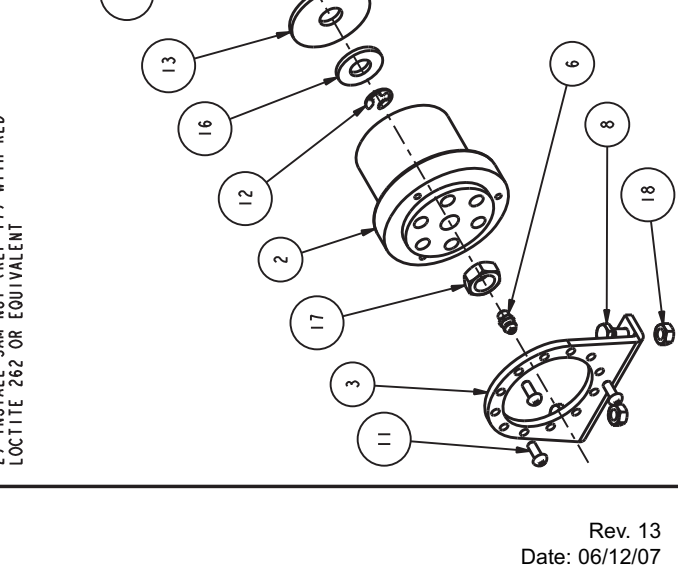
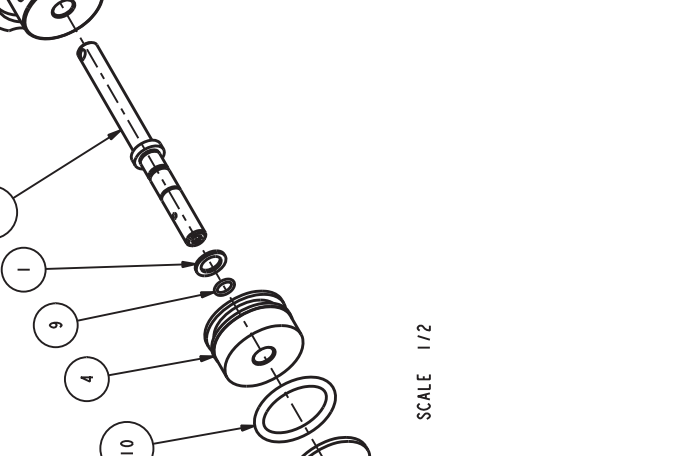
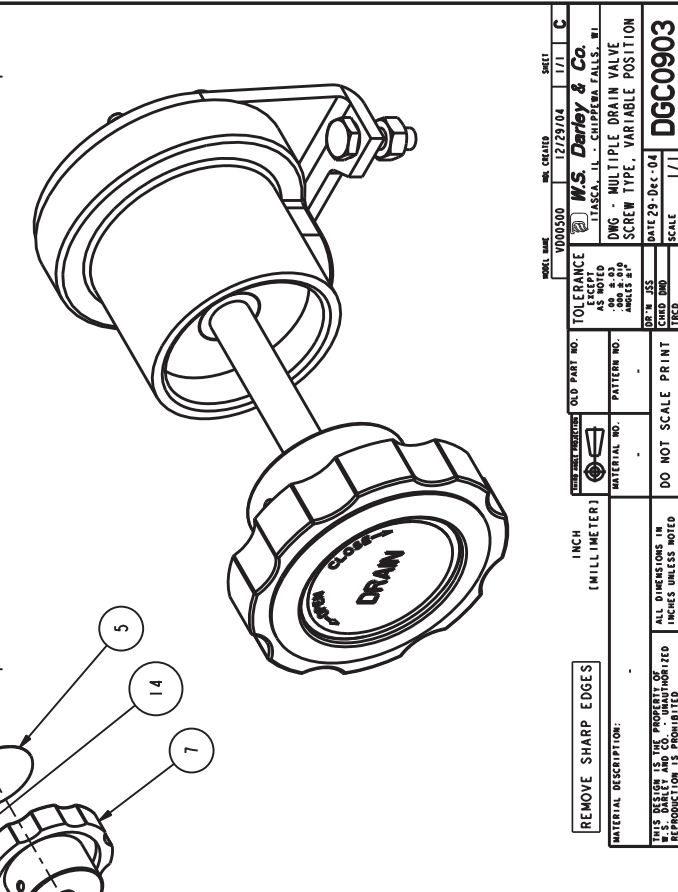
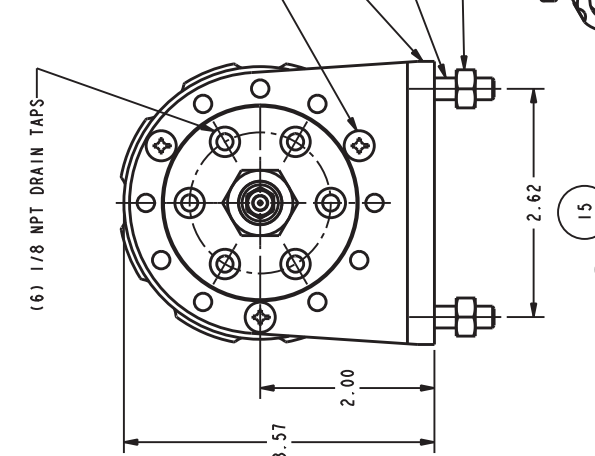
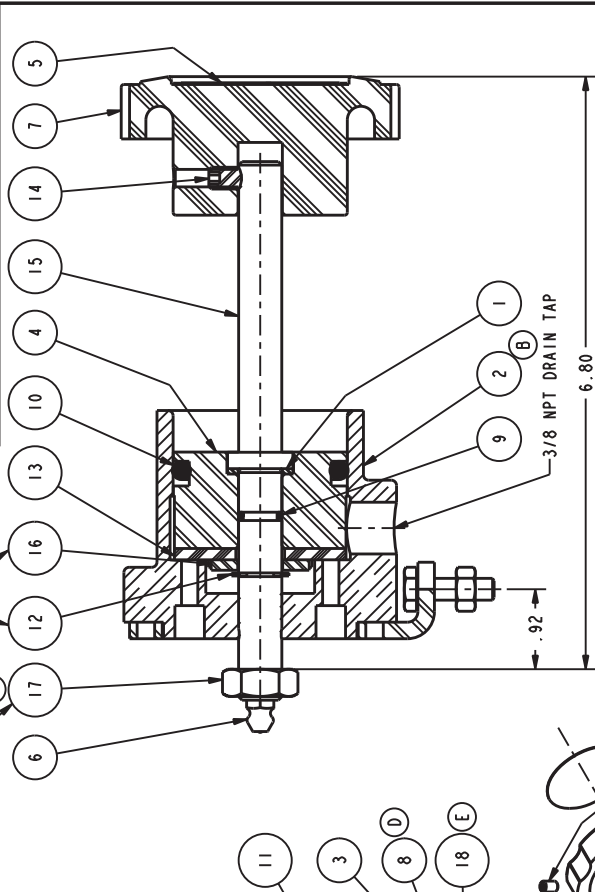

NOTE:  
 1) ASSEMBLE WASHER (REF 16) AND MATING RETAINING RING (REF 12) WITH SHARP EDGES FACING AWAY FROM SEAL (REF 13)  
 2) INSTALL JAM NUT (REF 17) WITH RED LOCTITE 262 OR EQUIVALENT

MODEL NAME	V000500	REV. CREATED	12/29/04	1/1	C
TOLERANCE	EXCEPT AS NOTED				
EXCEPT	AS SHOWN				
APPLICABLE TO	DWG - MULTIPLE DRAIN VALVE				
SCREW TYPE	VARIABLE POSITION				
DATE	29-Dec-04	SCALE	1/1	DGC0903	

REMOVE SHARP EDGES  
 INCH [MILLIMETER]  
 MATERIAL DESCRIPTION:  
 ALL DIMENSIONS IN INCHES UNLESS NOTED  
 THIS DESIGN IS THE PROPERTY OF WISCONSIN  
 REPRODUCTION IS PROHIBITED

## **BALL VALVE QUARTER TURN - SELF LOCKING**

The Darley Ball Valve is a quarter turn, all bronze valve designed for the fire service.

The ball is cast bronze, precision machined *stainless steel ball* for long trouble free service. It is easily serviced in the field.

The lever is self locking and easily adjusted, even under extreme high pressure.

### **TO DISASSEMBLE AND REPAIR THE BALL VALVE ILLUSTRATION DGC0100**

#### **TOOLS REQUIRED:**

- 3/16" Allen Wrench
  - 1-1/8" Wrench
  - 3/4" & 1" Wrench
  - Vise Grips or Pliers
1. Remove cap nut (20) and adjusting nut (16).
  2. Lever Assembly (11) pulls straight up. Watch for 2 cam balls (12).
  3. Unbolt and remove clutch ring (9), clutch sleeve (8), valve stem (7), spring (14), and valve stem washer (15). Check clutch ring (9) and sleeve (8) for scoring or excessive wear. Check o-ring (26). Replace if necessary.
  4. Remove nipple (2). Check Quad Ring (25). Replace if necessary.
  5. Unscrew ball guide screw (6). Check o-ring (23). Replace if necessary.
  6. Remove valve ball (3). Check for scratches, corrosion, and wear. Replace if necessary.
  7. Remove seat assembly (4). Check condition of rubber seat. Replace seat assembly if necessary.

### **REASSEMBLY OF BALL VALVE ILLUSTRATION DGC0100**

1. Position ball (3) in body so ball guide screw (6) engages bottom of ball as it is screwed into position.
2. Put valve stem (7) into position. Make certain stem engages slot on top of ball.
3. Slip washer (15), spring (14), and clutch sleeve (8) over the stem. Place clutch ring (9) over the sleeve and secure with the four (4) 1/4" NC x 5/8" socket head cap screws.
4. Set the two cam balls (12) into the V grooves in the clutch sleeve (8) and drop lever assembly over them. Tighten the adjusting nut (16) so that approximately 1/8" play is left at the end of a 6" lever. Over tightening this nut will make the clutch lock inoperative. Lock adjusting nut (16) with cap nut (20). Recheck this adjustment after valve is placed in service.
5. Place seat assembly (4), seat o-ring (5), and quad ring (25) into position.
6. Secure nipple (2) to valve body with eight (8) 1/4" NC x 5/8" socket head cap screws.

**If more information is needed, call W.S. DARLEY & CO. at  
Chippewa Falls, WI at 800-634-7812 or 715-726-2650**

LETTER	CHANGE NO.	DATE
(A)	96-53	5/15/96

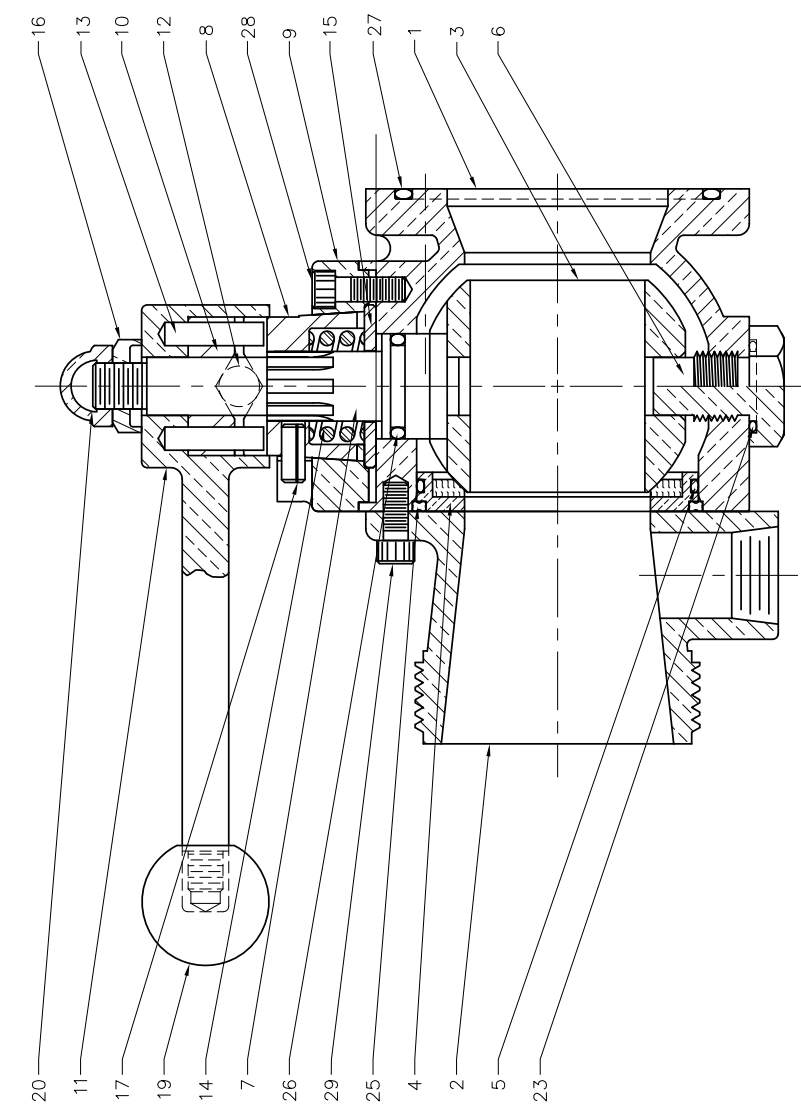

REP. NO.	NAME OF PART	QTY.
1	DISCHARGE VALVE BODY	1
2	VALVE NIPPLE	1
3	VALVE BALL	1
4	VALVE SEAT	1
5	O-RING	1
6	BALL GUIDE SCREW	1
7	VALVE STEM	1
8	CLUTCH SLEEVE	1
9	CLUTCH RING	1
10	LEVER CAM	1
11	FRONT MOUNT LEVER	1
12	CAM BALL	2
13	VALVE PIN	2
14	VALVE SPRING	1
15	VALVE STEM WASHER	1
16	ADJUSTING NUT	1
17	SPRING PIN-STL (A)	1
19	CONTROL LEVER BALL	1
20	CAP NUT	1
23	O-RING	1
25	QUAD RING	1
26	O-RING	1
27	O-RING	1
28	SOCKET HEAD CAP SCREW	4
29	SOCKET HEAD CAP SCREW	8

THIRD ANGLE PROJECTION

INCH  
[MILLIMETER]

**W.S. DARLEY & Co.**  
MELROSE PARK, IL - CHIPPEWA FALLS, WI

DWG - BALL VALVE ASSEMBLY  
CROSS SECTION

DATE NOV12.65  
SCALE 1/1

**DGC0100**

TOLERANCE  
EXCEPT AS NOTED  
FRACTIONS ±0.005  
DECIMALS ±0.010  
ANGLES 31'

OLD PART NO. G1200

DO NOT SCALE PRINT

ALL DIMENSIONS IN PROPS UNLESS NOTED

THIS DESIGN IS THE PROPERTY OF W.S. DARLEY AND CO. - UNAUTHORIZED REPRODUCTION IS PROHIBITED

## **REMOTE CONTROL SUCTION RELIEF VALVE DRAWING DGC0115**

The suction relief valve bypasses water from the pump suction extension to the ground at a set pressure, preventing excessive rise of supply pressure when relay hose lines are shut off.

Turning pressure setting hand wheel (14) clockwise raises the relief pressure, and counterclockwise lowers it.

The self cleaning fine mesh strainer will prevent entry of solids that could cause the relief valve to malfunction. Open the strainer flush valve to remove small accumulations. This is accomplished by turning the strainer flush valve knob (6) counterclockwise 2 to 3 full turns. Strainer trapped debris will be flushed to the ground. Pump supply pressure should be 50-100 PSI when performing this procedure.

### **TO SET SUCTION RELIEF VALVE**

1. Connect a discharge line from an auxiliary pump to the pump suction containing the suction relief valve. The auxiliary pump must be able to supply a pressure greater than the desired pressure setting of the suction relief valve.
2. Close all other discharge and suction valves.
3. Increase auxiliary pump engine throttle setting until pressure gage indicates the pressure that suction relief valve is open.
4. If suction relief valve opens to bypass excessive pressure, slowly turn hand wheel (14) clockwise until valve closes.
5. If suction relief valve does not open, turn hand wheel (14) counterclockwise until valve opens and begins bypassing water. Continue to turn hand wheel (14) counterclockwise 2 more complete turns. Now slowly turn hand wheel clockwise until valve closes and stops bypassing water.

The suction relief valve will now prevent damage to the pump from a pressure surge (water hammer) which is the result of rapid closing or opening of relay line valves.

Should a higher or lower relief pressure be desired, repeat the above procedure.

**CAUTION:** With all discharge valves closed, the water in auxiliary pump casing will heat up rapidly. Avoid damage by allowing a very low flow of water to discharge when pump is running.

## **REMOTE CONTROL SUCTION RELIEF VALVE WITH MECHANICAL SHUTOFF DRAWING DGC0115**

### **MAINTENANCE**

Open the relief valve strainer flush valve (6) during every operation at 50-100 PSI supply pressure to insure against foreign material blocking the screen.

The relief valve, pilot unit, and strainer assemblies should be taken apart for inspection and cleaning at least annually, or as often as found necessary to insure trouble free performance.

To disassemble pilot head, first turn hand wheel (14) counterclockwise to remove spring compression. Remove the four 1/4" screws holding regulator spring housing (18). Lift out diaphragm (23) and pilot valve (51) assembly. Clean and make certain 3/32" diameter orifice hole is free of obstruction.

When reassembling pilot head, turn hand wheel (14) a few times clockwise to compress spring before tightening four screws holding spring housing. This will properly center valve seat and diaphragm.

The valve piston (40) and spring (44) chamber should be inspected and cleaned.

Replace diaphragm and o-rings if damaged or deteriorated.



Apply a thin coating of waterproof grease lubricant: to spring housing counterbore that guides pilot valve (51) and ball (52), to end of tension screw (17), and between piston (40) and center post

Self cleaning strainer (63) can be removed for inspection or replacement by alternately turning valve knob (6) and stop nut (7) counterclockwise until stem is free for removal. To avoid discharging water through opening created by stem (62) removal, pump should be completely shut down before stem (62) is removed. Inspect and clean screen (63) if required. Check quad ring (64) for damage or deterioration. Reverse procedure to reassemble valve. Use care when initially inserting screen into body to avoid damaging quad ring (64) or valve seat.

To replace flush valve seat (69), remove stem/screen assembly. Disconnect tubing lines attached to (61) body half, unscrew (61) body half from (70) body half. Replace (69) valve seat. Reverse procedure to reassemble valve.

### SUCTION RELIEF VALVE PARTS LIST DRAWING DGC0115

REP NO.	DESCRIPTION	REP NO.	DESCRIPTION
3	Decal - RV Flush	41	Relief Valve Body
4	Panel Nut	42	O-ring Flange
5	Socket Set Screw	43	Spring Centering Plug
6	Flush Valve Knob	44	Spring
7	Stop Nut	45	O-ring Body Flange
11	Panel Valve Nut	46	O-ring Piston
12	Decal - Pressure Hi-Lo	50	O-ring, Bleed Port
13	Trim Plate	51	Pilot Valve
14	Hand wheel	52	Ball
16	Socket Set Screw	53	Pilot Valve Body
17	Spring Tension Screw	61	Body Half, Flush Valve
18	Spring Housing	62	Stem
19	Spring Retainer	63	Screen
20	Regulator Spring	64	Quad Ring
21	Pilot Valve Nut	66	O-ring Valve Seat
22	Housing Pilot Ring	67	Valve Seat Ring
23	Diaphragm	68	O-ring Flush Valve Body
37	O-ring, Relief Valve Head	69	Flush Valve Seat
38	Relief Valve Head	70	Body Half, Flush Valve
40	Relief Valve Piston	84	Flange
		86	Lock Washer Internal

**IF FURTHER INFORMATION IS NEEDED, CALL W.S. DARLEY & CO. AT  
CHIPPEWA FALLS, WI. AT 800-634-7812 or 715-726-2650**

REVISIONS

LTR	DESCRIPTION	DATE	CHG NO.	APPROV
A	ADDED LOCTITING NOTE	4NOV2002	2002-175	TED

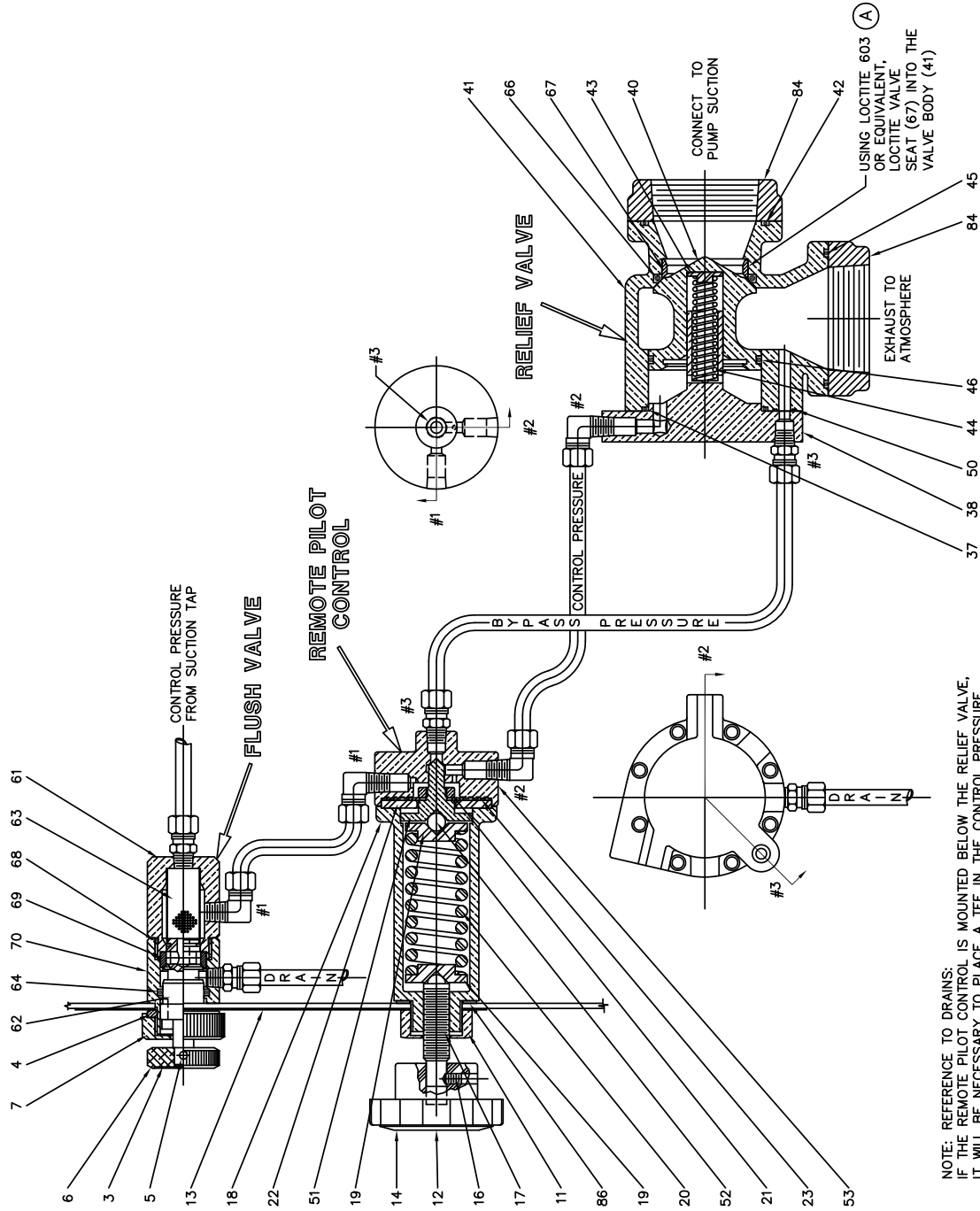

NOTE: REFERENCE TO DRAINS:  
 IF THE REMOTE PILOT CONTROL IS MOUNTED BELOW THE RELIEF VALVE, IT WILL BE NECESSARY TO PLACE A TEE IN THE CONTROL PRESSURE LINE AND BYPASS PRESSURE LINE, AT THE LOWEST POINT, TO PROVIDE DRAINING. SUCH A DRAIN, IF INSTALLED, SHOULD NOT BE CONNECTED TOGETHER WITH THE RELIEF VALVE DRAIN. CONNECT DRAIN LINES TO SEPARATE INLET TAPS OF MULTIPLE DRAIN VALVE. DRAINS MUST BE CLOSED DURING OPERATION.

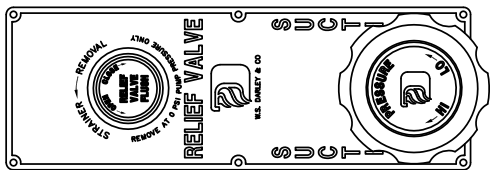

TOLERANCE FRAC IN AS NOTED DECIMAL ANGLES 21°		OLD PART NO. G2453		DATE DEC17,91	
MATERIAL NO.		PATTERN NO.		SCALE 1/2	
ALL DIMENSIONS IN INCHES UNLESS NOTED		DO NOT SCALE PRINT		DWG -- SUCTION RELIEF VALVE	
MATERIAL DESCRIPTION: THIS DESIGN IS THE PROPERTY OF W.S. DARLEY AND CO. UNAUTHORIZED REPRODUCTION IS PROHIBITED		DRN S. LEE		DATE DEC17,91	
		CHD		SCALE 1/2	
		TRCD		DGC0115	

W.S. DARLEY & CO.  
 MELROSE PARK, ILL. - CHIPPEVA FALLS, WI

# **W.S. DARLEY & CO.**

## **REMOTE CONTROL PRESSURE RELIEF VALVE WITH MECHANICAL SHUTOFF**

### **Refer to Drawing DGC0141**

The relief valve bypasses water from the pump discharge manifold to the suction chamber at a set pump pressure, preventing excessive rise of discharge pressure when hose lines are shut off.

Turning pressure setting hand wheel (14) clockwise raises the relief pressure, and counter clockwise lowers it.

The self-cleaning fine mesh strainer will prevent the entry of solids that could cause the relief valve to malfunction. Open the strainer flush valve to remove small accumulations. This is accomplished by turning the strainer flush valve knob (6) counter clockwise 2 to 3 full turns. Strainer trapped debris will be flushed to the ground. Pump supply pressure should be 50-100 PSI when performing this procedure.

### **TO SET RELIEF VALVE**

- 1.** Turn four-way valve OFF.
- 2.** Open at least one discharge valve and increase engine throttle setting until pressure gage indicates the pressure at which relief valve is to open.
- 3.** Turn four-way valve ON.
- 4.** If gage reading drops below pressure set in step 2, turn hand wheel (14) clockwise until pressure returns to set point.
- 5.** If gage reading does not drop, turn hand wheel (14) counter clockwise until pressure drops 5 to 10 PSI below set point. Then slowly turn hand wheel clockwise until pressure returns to pressure set in step 2.

The relief valve will now prevent the discharge pressure from rising above that for which it is set, and requires no further attention.

Should a higher or lower relief pressure be desired, repeat above procedure.

### **CAUTION**

With all discharge valves closed, water in the auxiliary pump casing will heat up rapidly. To avoid possible damage, allow a very small stream of water to discharge when the pump is running.

# REMOTE CONTROL PRESSURE RELIEF VALVE WITH MECHANICAL SHUTOFF

## MAINTENANCE DRAWING DGC0141

Open the relief valve strainer flush valve (6) during every operation at 50-100 PSI supply pressure to insure foreign material is not blocking the screen.

The 3/32" diameter metering orifice and diaphragm chamber at (21) may be back-flushed if necessary while the pump is delivering water by opening the pilot head drain and placing valve handle (9) midway between ON and OFF position.

The relief valve, pilot unit, and strainer assemblies should be taken apart for inspection and cleaning at least annually, or as often as found necessary to insure trouble free performance.

To disassemble pilot head, first turn hand wheel (14) counter clockwise to remove spring compression. Remove the four 1/4" screws holding regulator spring housing (18). Lift out diaphragm (23) and pilot valve (51) assembly. Clean and make certain 3/32" diameter orifice hole is free of obstruction.

When reassembling pilot head, turn hand wheel (14) a few times clockwise to compress spring before tightening four screws holding spring housing. This will properly center valve seat and diaphragm.

The valve piston (40) and spring (44) chamber should be inspected and cleaned.

Replace diaphragm and o-rings if damaged or deteriorated.

Apply a thin coating of waterproof grease lubricant: to spring housing counterbore that guides the pilot valve (51) and ball (52), to end of tension screw (17), and between piston (40) and center post.

Self-cleaning strainer (63) can be removed for inspection or replacement by alternately turning valve knob (6) and stop nut (7) counter clockwise until stem is free for removal. To avoid discharging water through opening created by stem (62) removal, pump should be completely shut down before stem (62) is removed. Inspect and clean screen (63) if required. Check quad ring (64) for damage or deterioration. Reverse procedure to reassemble valve. Use care when initially inserting screen into body to avoid damaging quad ring (64) or valve seat.

To replace flush valve seat (69), remove stem/screen assembly, disconnect tubing lines attached to (61) body half and unscrew (61) body half from (70) body half. Replace (69) valve seat. Reverse procedure to reassemble valve.

All Darley relief valves can be provided with a micro switch and either one or two pilot lights to indicate when the valve is open or closed.

**IF FURTHER INFORMATION IS NEEDED, CALL W.S. DARLEY & CO. AT  
CHIPPEWA FALLS, WI. AT 800-634-7812 or 715-726-2650**

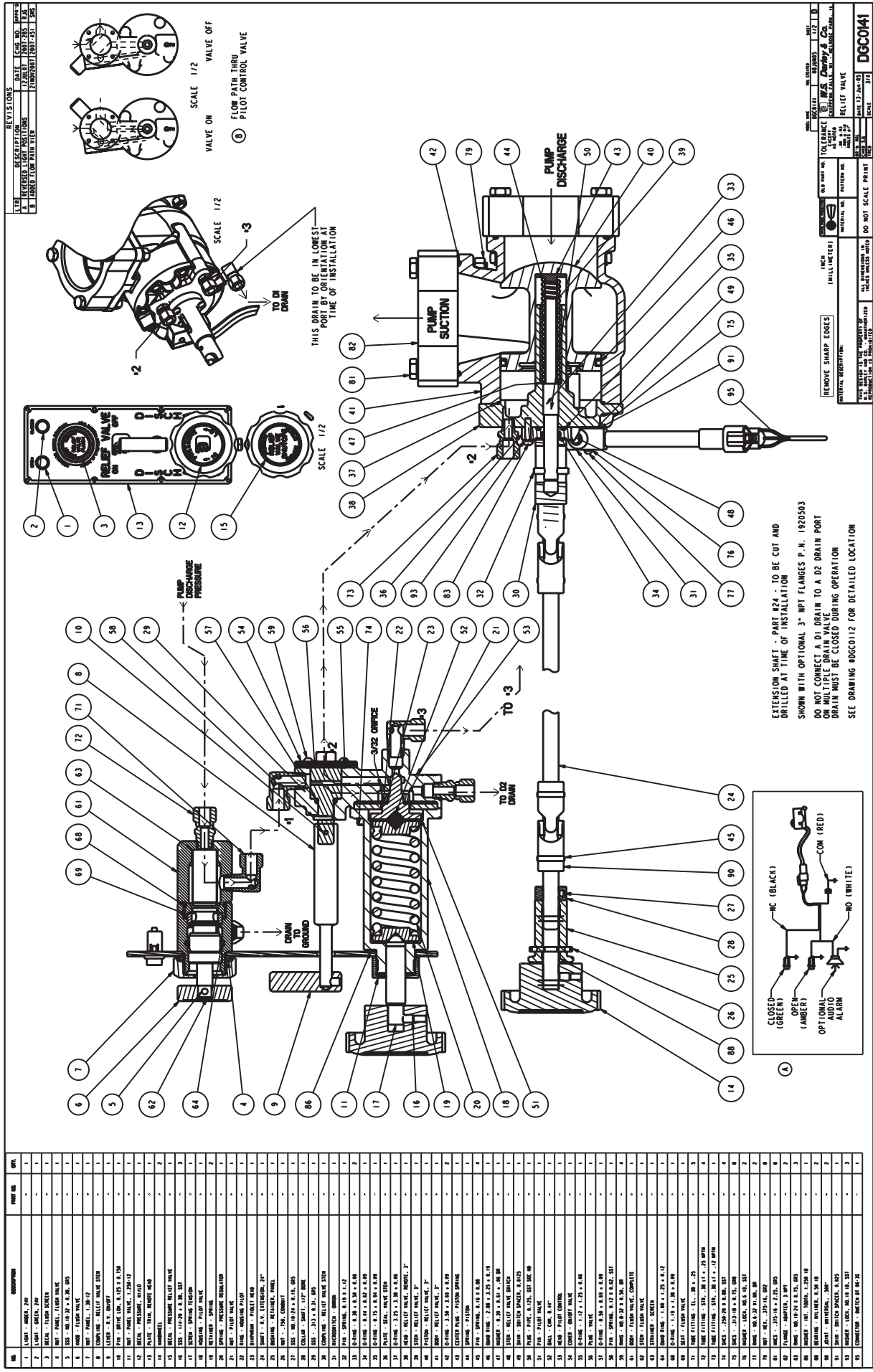

NO.	DESCRIPTION	QTY	UNIT
1	SCREW - 1/4" X 1/2"	1	
2	SCREW - 1/4" X 1/2"	1	
3	SCREW - 1/4" X 1/2"	1	
4	SCREW - 1/4" X 1/2"	1	
5	SCREW - 1/4" X 1/2"	1	
6	SCREW - 1/4" X 1/2"	1	
7	SCREW - 1/4" X 1/2"	1	
8	SCREW - 1/4" X 1/2"	1	
9	SCREW - 1/4" X 1/2"	1	
10	SCREW - 1/4" X 1/2"	1	
11	SCREW - 1/4" X 1/2"	1	
12	SCREW - 1/4" X 1/2"	1	
13	SCREW - 1/4" X 1/2"	1	
14	SCREW - 1/4" X 1/2"	1	
15	SCREW - 1/4" X 1/2"	1	
16	SCREW - 1/4" X 1/2"	1	
17	SCREW - 1/4" X 1/2"	1	
18	SCREW - 1/4" X 1/2"	1	
19	SCREW - 1/4" X 1/2"	1	
20	SCREW - 1/4" X 1/2"	1	
21	SCREW - 1/4" X 1/2"	1	
22	SCREW - 1/4" X 1/2"	1	
23	SCREW - 1/4" X 1/2"	1	
24	SCREW - 1/4" X 1/2"	1	
25	SCREW - 1/4" X 1/2"	1	
26	SCREW - 1/4" X 1/2"	1	
27	SCREW - 1/4" X 1/2"	1	
28	SCREW - 1/4" X 1/2"	1	
29	SCREW - 1/4" X 1/2"	1	
30	SCREW - 1/4" X 1/2"	1	
31	SCREW - 1/4" X 1/2"	1	
32	SCREW - 1/4" X 1/2"	1	
33	SCREW - 1/4" X 1/2"	1	
34	SCREW - 1/4" X 1/2"	1	
35	SCREW - 1/4" X 1/2"	1	
36	SCREW - 1/4" X 1/2"	1	
37	SCREW - 1/4" X 1/2"	1	
38	SCREW - 1/4" X 1/2"	1	
39	SCREW - 1/4" X 1/2"	1	
40	SCREW - 1/4" X 1/2"	1	
41	SCREW - 1/4" X 1/2"	1	
42	SCREW - 1/4" X 1/2"	1	
43	SCREW - 1/4" X 1/2"	1	
44	SCREW - 1/4" X 1/2"	1	
45	SCREW - 1/4" X 1/2"	1	
46	SCREW - 1/4" X 1/2"	1	
47	SCREW - 1/4" X 1/2"	1	
48	SCREW - 1/4" X 1/2"	1	
49	SCREW - 1/4" X 1/2"	1	
50	SCREW - 1/4" X 1/2"	1	
51	SCREW - 1/4" X 1/2"	1	
52	SCREW - 1/4" X 1/2"	1	
53	SCREW - 1/4" X 1/2"	1	
54	SCREW - 1/4" X 1/2"	1	
55	SCREW - 1/4" X 1/2"	1	
56	SCREW - 1/4" X 1/2"	1	
57	SCREW - 1/4" X 1/2"	1	
58	SCREW - 1/4" X 1/2"	1	
59	SCREW - 1/4" X 1/2"	1	
60	SCREW - 1/4" X 1/2"	1	
61	SCREW - 1/4" X 1/2"	1	
62	SCREW - 1/4" X 1/2"	1	
63	SCREW - 1/4" X 1/2"	1	
64	SCREW - 1/4" X 1/2"	1	
65	SCREW - 1/4" X 1/2"	1	
66	SCREW - 1/4" X 1/2"	1	
67	SCREW - 1/4" X 1/2"	1	
68	SCREW - 1/4" X 1/2"	1	
69	SCREW - 1/4" X 1/2"	1	
70	SCREW - 1/4" X 1/2"	1	
71	SCREW - 1/4" X 1/2"	1	
72	SCREW - 1/4" X 1/2"	1	
73	SCREW - 1/4" X 1/2"	1	
74	SCREW - 1/4" X 1/2"	1	
75	SCREW - 1/4" X 1/2"	1	
76	SCREW - 1/4" X 1/2"	1	
77	SCREW - 1/4" X 1/2"	1	
78	SCREW - 1/4" X 1/2"	1	
79	SCREW - 1/4" X 1/2"	1	
80	SCREW - 1/4" X 1/2"	1	
81	SCREW - 1/4" X 1/2"	1	
82	SCREW - 1/4" X 1/2"	1	
83	SCREW - 1/4" X 1/2"	1	
84	SCREW - 1/4" X 1/2"	1	
85	SCREW - 1/4" X 1/2"	1	
86	SCREW - 1/4" X 1/2"	1	
87	SCREW - 1/4" X 1/2"	1	
88	SCREW - 1/4" X 1/2"	1	
89	SCREW - 1/4" X 1/2"	1	
90	SCREW - 1/4" X 1/2"	1	
91	SCREW - 1/4" X 1/2"	1	
92	SCREW - 1/4" X 1/2"	1	
93	SCREW - 1/4" X 1/2"	1	
94	SCREW - 1/4" X 1/2"	1	
95	SCREW - 1/4" X 1/2"	1	

REV.	DESCRIPTION	DATE	SCALE	NO.	BY
1	REVISED LIGHT POSITIONS	12/08/03	1:2	125	EAP
2	ADDED FLOW PATH VIEW	12/08/03	1:2	126	EAP

REV.	DESCRIPTION	DATE	SCALE	NO.	BY
1	REVISED LIGHT POSITIONS	12/08/03	1:2	125	EAP
2	ADDED FLOW PATH VIEW	12/08/03	1:2	126	EAP

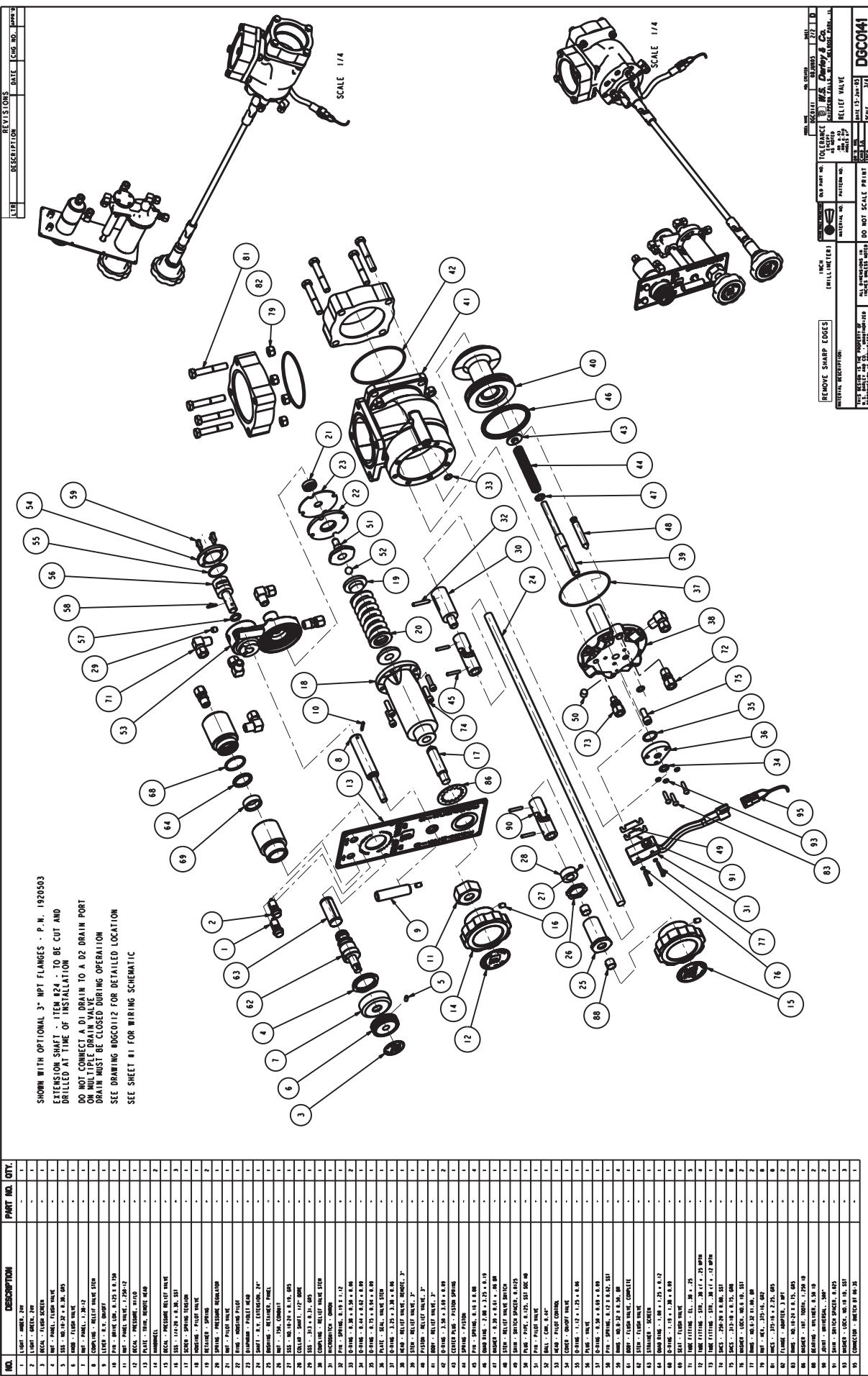

SHOWN WITH OPTIONAL 3" MPT FLANGES - P. H. 1920503  
 EXTENSION SHAFT - ITEM #24 - TO BE CUT AND  
 DRILLED AT TIME OF INSTALLATION  
 DO NOT CONNECT A D1 DRAIN TO A D2 DRAIN PORT  
 ON MULTIPLE DRAIN VALVE  
 DRAIN MUST BE CLOSED DURING OPERATION  
 SEE DRAWING #DGC0112 FOR DETAILED SCHEMATIC  
 SEE SHEET #1 FOR WIRING SCHEMATIC

NO.	DESCRIPTION	PART NO.	QTY.
1	WASHER - 1/4" X 1/8"	1	1
2	WASHER - 1/4" X 1/8"	2	1
3	WASHER - 1/4" X 1/8"	3	1
4	WASHER - 1/4" X 1/8"	4	1
5	WASHER - 1/4" X 1/8"	5	1
6	WASHER - 1/4" X 1/8"	6	1
7	WASHER - 1/4" X 1/8"	7	1
8	WASHER - 1/4" X 1/8"	8	1
9	WASHER - 1/4" X 1/8"	9	1
10	WASHER - 1/4" X 1/8"	10	1
11	WASHER - 1/4" X 1/8"	11	1
12	WASHER - 1/4" X 1/8"	12	1
13	WASHER - 1/4" X 1/8"	13	1
14	WASHER - 1/4" X 1/8"	14	1
15	WASHER - 1/4" X 1/8"	15	1
16	WASHER - 1/4" X 1/8"	16	1
17	WASHER - 1/4" X 1/8"	17	1
18	WASHER - 1/4" X 1/8"	18	1
19	WASHER - 1/4" X 1/8"	19	1
20	WASHER - 1/4" X 1/8"	20	1
21	WASHER - 1/4" X 1/8"	21	1
22	WASHER - 1/4" X 1/8"	22	1
23	WASHER - 1/4" X 1/8"	23	1
24	WASHER - 1/4" X 1/8"	24	1
25	WASHER - 1/4" X 1/8"	25	1
26	WASHER - 1/4" X 1/8"	26	1
27	WASHER - 1/4" X 1/8"	27	1
28	WASHER - 1/4" X 1/8"	28	1
29	WASHER - 1/4" X 1/8"	29	1
30	WASHER - 1/4" X 1/8"	30	1
31	WASHER - 1/4" X 1/8"	31	1
32	WASHER - 1/4" X 1/8"	32	1
33	WASHER - 1/4" X 1/8"	33	1
34	WASHER - 1/4" X 1/8"	34	1
35	WASHER - 1/4" X 1/8"	35	1
36	WASHER - 1/4" X 1/8"	36	1
37	WASHER - 1/4" X 1/8"	37	1
38	WASHER - 1/4" X 1/8"	38	1
39	WASHER - 1/4" X 1/8"	39	1
40	WASHER - 1/4" X 1/8"	40	1
41	WASHER - 1/4" X 1/8"	41	1
42	WASHER - 1/4" X 1/8"	42	1
43	WASHER - 1/4" X 1/8"	43	1
44	WASHER - 1/4" X 1/8"	44	1
45	WASHER - 1/4" X 1/8"	45	1
46	WASHER - 1/4" X 1/8"	46	1
47	WASHER - 1/4" X 1/8"	47	1
48	WASHER - 1/4" X 1/8"	48	1
49	WASHER - 1/4" X 1/8"	49	1
50	WASHER - 1/4" X 1/8"	50	1
51	WASHER - 1/4" X 1/8"	51	1
52	WASHER - 1/4" X 1/8"	52	1
53	WASHER - 1/4" X 1/8"	53	1
54	WASHER - 1/4" X 1/8"	54	1
55	WASHER - 1/4" X 1/8"	55	1
56	WASHER - 1/4" X 1/8"	56	1
57	WASHER - 1/4" X 1/8"	57	1
58	WASHER - 1/4" X 1/8"	58	1
59	WASHER - 1/4" X 1/8"	59	1
60	WASHER - 1/4" X 1/8"	60	1
61	WASHER - 1/4" X 1/8"	61	1
62	WASHER - 1/4" X 1/8"	62	1
63	WASHER - 1/4" X 1/8"	63	1
64	WASHER - 1/4" X 1/8"	64	1
65	WASHER - 1/4" X 1/8"	65	1
66	WASHER - 1/4" X 1/8"	66	1
67	WASHER - 1/4" X 1/8"	67	1
68	WASHER - 1/4" X 1/8"	68	1
69	WASHER - 1/4" X 1/8"	69	1
70	WASHER - 1/4" X 1/8"	70	1
71	WASHER - 1/4" X 1/8"	71	1
72	WASHER - 1/4" X 1/8"	72	1
73	WASHER - 1/4" X 1/8"	73	1
74	WASHER - 1/4" X 1/8"	74	1
75	WASHER - 1/4" X 1/8"	75	1
76	WASHER - 1/4" X 1/8"	76	1
77	WASHER - 1/4" X 1/8"	77	1
78	WASHER - 1/4" X 1/8"	78	1
79	WASHER - 1/4" X 1/8"	79	1
80	WASHER - 1/4" X 1/8"	80	1
81	WASHER - 1/4" X 1/8"	81	1
82	WASHER - 1/4" X 1/8"	82	1
83	WASHER - 1/4" X 1/8"	83	1
84	WASHER - 1/4" X 1/8"	84	1
85	WASHER - 1/4" X 1/8"	85	1
86	WASHER - 1/4" X 1/8"	86	1
87	WASHER - 1/4" X 1/8"	87	1
88	WASHER - 1/4" X 1/8"	88	1
89	WASHER - 1/4" X 1/8"	89	1
90	WASHER - 1/4" X 1/8"	90	1
91	WASHER - 1/4" X 1/8"	91	1
92	WASHER - 1/4" X 1/8"	92	1
93	WASHER - 1/4" X 1/8"	93	1
94	WASHER - 1/4" X 1/8"	94	1
95	WASHER - 1/4" X 1/8"	95	1

REV. NO.	REV. DATE	REV. BY	REV. FOR
1	05/20/10	EAP	ISSUE FOR PRODUCTION
2	06/12/07	EAP	ISSUE FOR PRODUCTION
3	05/20/10	EAP	ISSUE FOR PRODUCTION

NO. 1	NO. 2	NO. 3	NO. 4
1	2	3	4
5	6	7	8
9	10	11	12

NO. 13	NO. 14	NO. 15	NO. 16
13	14	15	16
17	18	19	20
21	22	23	24

NO. 25	NO. 26	NO. 27	NO. 28
25	26	27	28
29	30	31	32
33	34	35	36

NO. 37	NO. 38	NO. 39	NO. 40
37	38	39	40
41	42	43	44
45	46	47	48

NO. 49	NO. 50	NO. 51	NO. 52
49	50	51	52
53	54	55	56
57	58	59	60

REVOLUTIONS	
DATE	REV. NO.
DESCRIPTION	BY
1.1	1
1.2	2

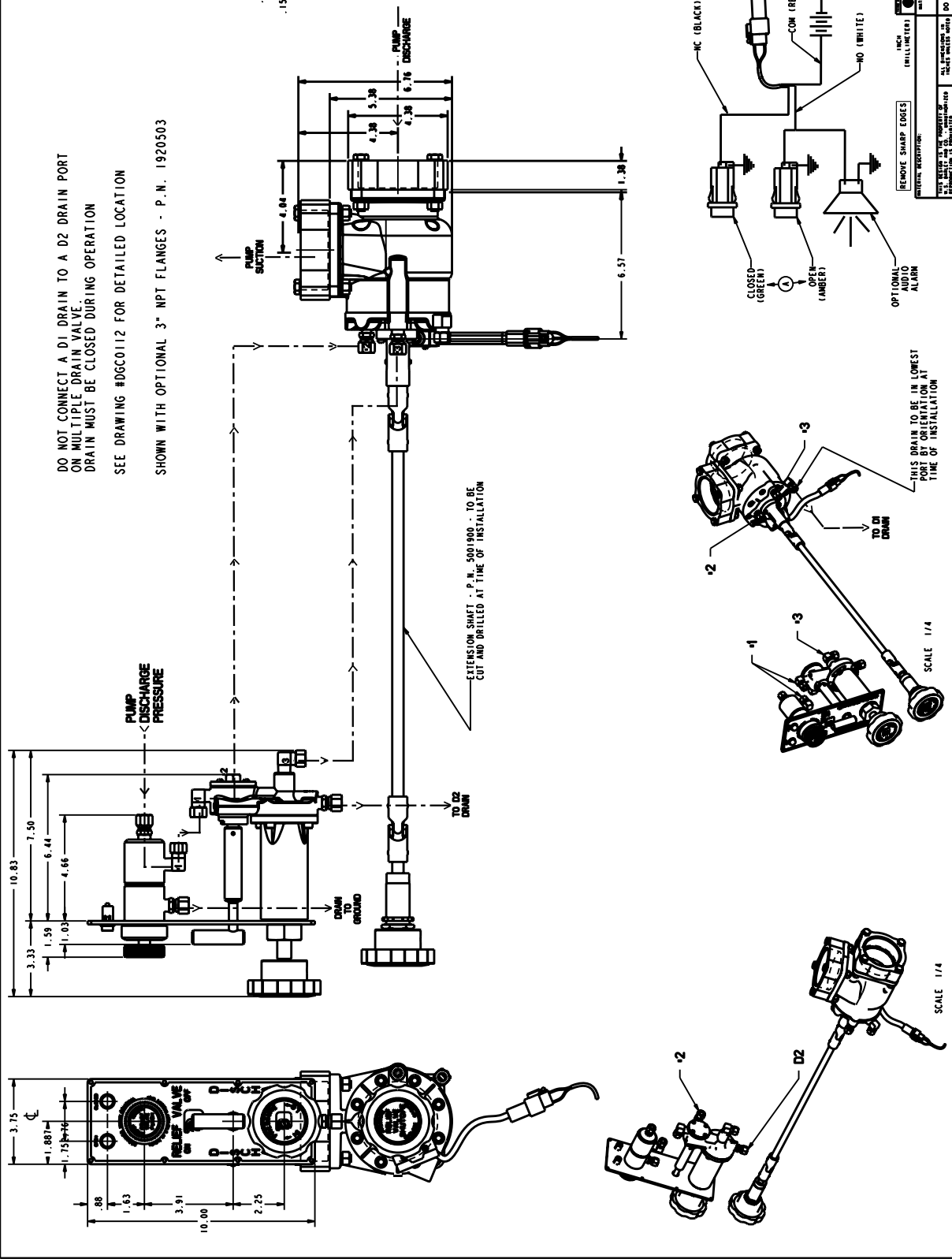

Prepared By: EAP  
 Revised By: EAP  
 Approved By: TED

# W.S. DARLEY & CO.

## Relief Valve Alarm Installation Instruction

**This Alarm is designed to concentrate audible sound in the operator zone only. For optimum Performance, position alarm sound opening so it is facing the operator at a distance of 24 - 36 inches.**

Mount unit in 1.12 diameter panel hole. If panel is thicker than .09 inches, invert nut.

Do not mount with sound opening in an upward position. Do not obstruct opening.

Connect to 12 VDC only.

Two (2) wires are required to complete the circuit. The alarm is sensitive to polarity and will not operate if connected with polarity reversed.

### Relief Valve Alarm Installation Instructions

THIS ALARM IS DESIGNED TO CONCENTRATE AUDIBLE SOUND IN THE OPERATOR ZONE ONLY. FOR OPTIMUM PERFORMANCE, POSITION ALARM SOUND OPENING SO IT IS FACING THE OPERATOR AT A DISTANCE OF 24-36 INCHES.

MOUNT UNIT IN 1.12 DIAMETER PANEL HOLE. IF PANEL IS THICKER THAN .09 IN., INVERT NUT.

DO NOT MOUNT WITH SOUND OPENING IN AN UPWARD POSITION. DO NOT OBSTRUCT OPENING.

CONNECT TO 12 VDC ONLY.

TWO (2) WIRES ARE REQUIRED TO COMPLETE THE CIRCUIT. THE ALARM IS SENSITIVE TO POLARITY AND WILL NOT OPERATE IF CONNECTED WITH POLARITY REVERSED.

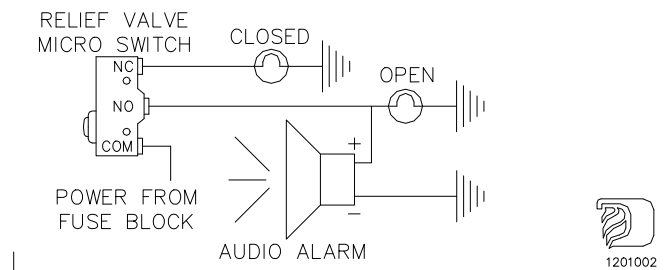

**IF FURTHER INFORMATION IS NEEDED, CALL W.S. DARLEY & CO. AT  
CHIPPEWA FALLS, WI. AT 800-634-7812 or 715-726-2650**





ATTACH WARNING PLATE  
(ASSY AM00700) TO  
CONTROL PANEL VIA  
REV. NO. 96-115 (REF). ©

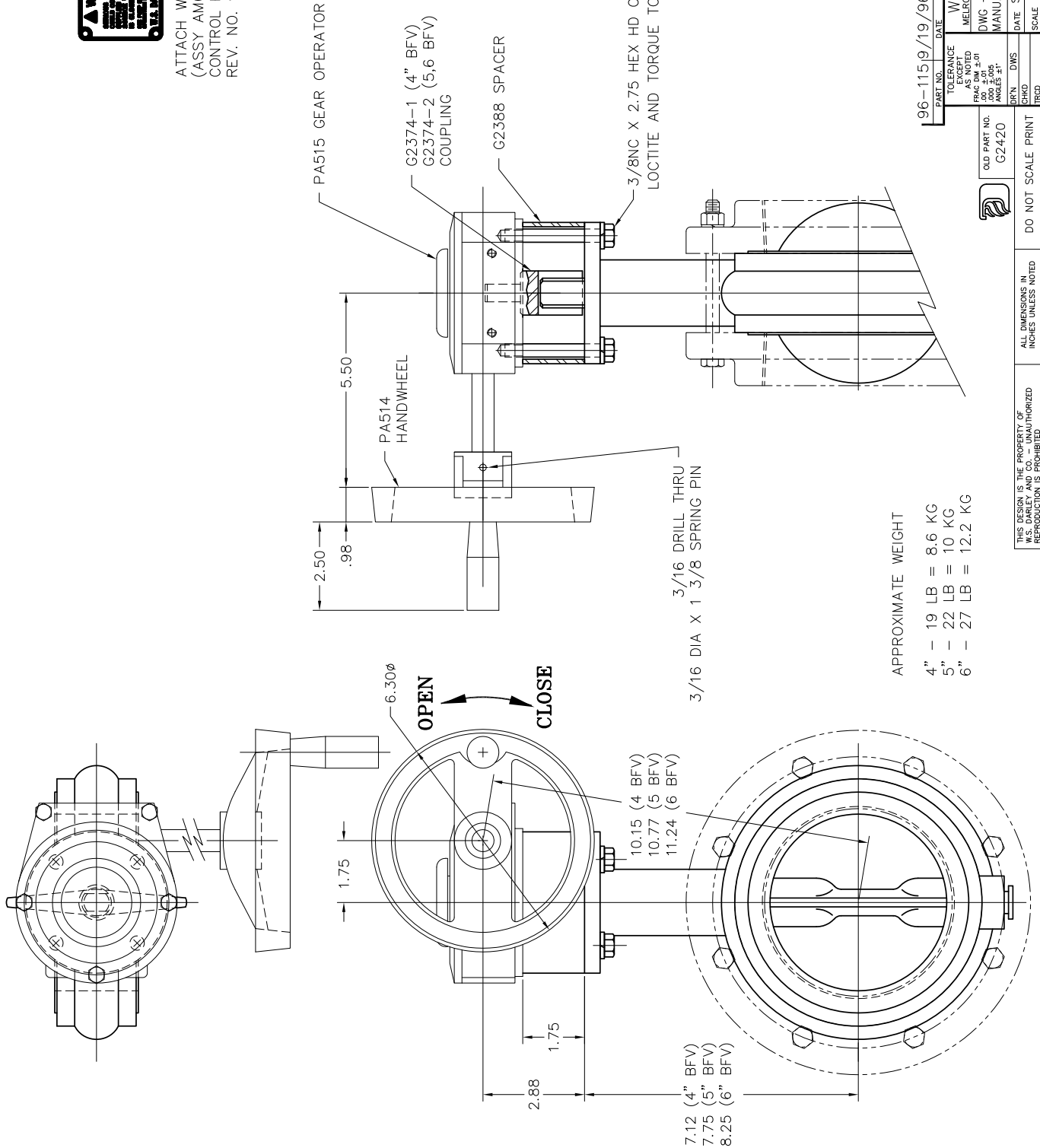

APPROXIMATE WEIGHT  
 4" - 19 LB = 8.6 KG  
 5" - 22 LB = 10 KG  
 6" - 27 LB = 12.2 KG

96-115	9/19/96	ADDED PLATE LMH
CHANGE		
TITLE	DATE	CHANGE
W.S. DARLEY & CO.		
MELROSE PARK, IL - CHIPPEWA FALLS, WI		
DWG - BTRFLY VALVE ASSY		
MANUAL CONTROLLED		
DATE	SEP 25, 91	
DRN	DWS	
CHD		
TRCD		
SCALE	1/2	

THIS DESIGN IS THE PROPERTY OF  
W.S. DARLEY AND CO. - UNAUTHORIZED  
REPRODUCTION IS PROHIBITED

ALL DIMENSIONS IN  
INCHES UNLESS NOTED

DO NOT SCALE PRINT

OLD PART NO.  
G2420

W.S. DARLEY & CO.  
MELROSE PARK, IL - CHIPPEWA FALLS, WI  
DWG - BTRFLY VALVE ASSY  
MANUAL CONTROLLED  
DATE SEP 25, 91  
DRN DWS  
CHD  
TRCD  
SCALE 1/2

DGD0104



ATTACH WARNING PLATE  
(ASSY AM00700) TO  
CONTROL PANEL VIA  
REV. NO. 96-115 (REF). ©

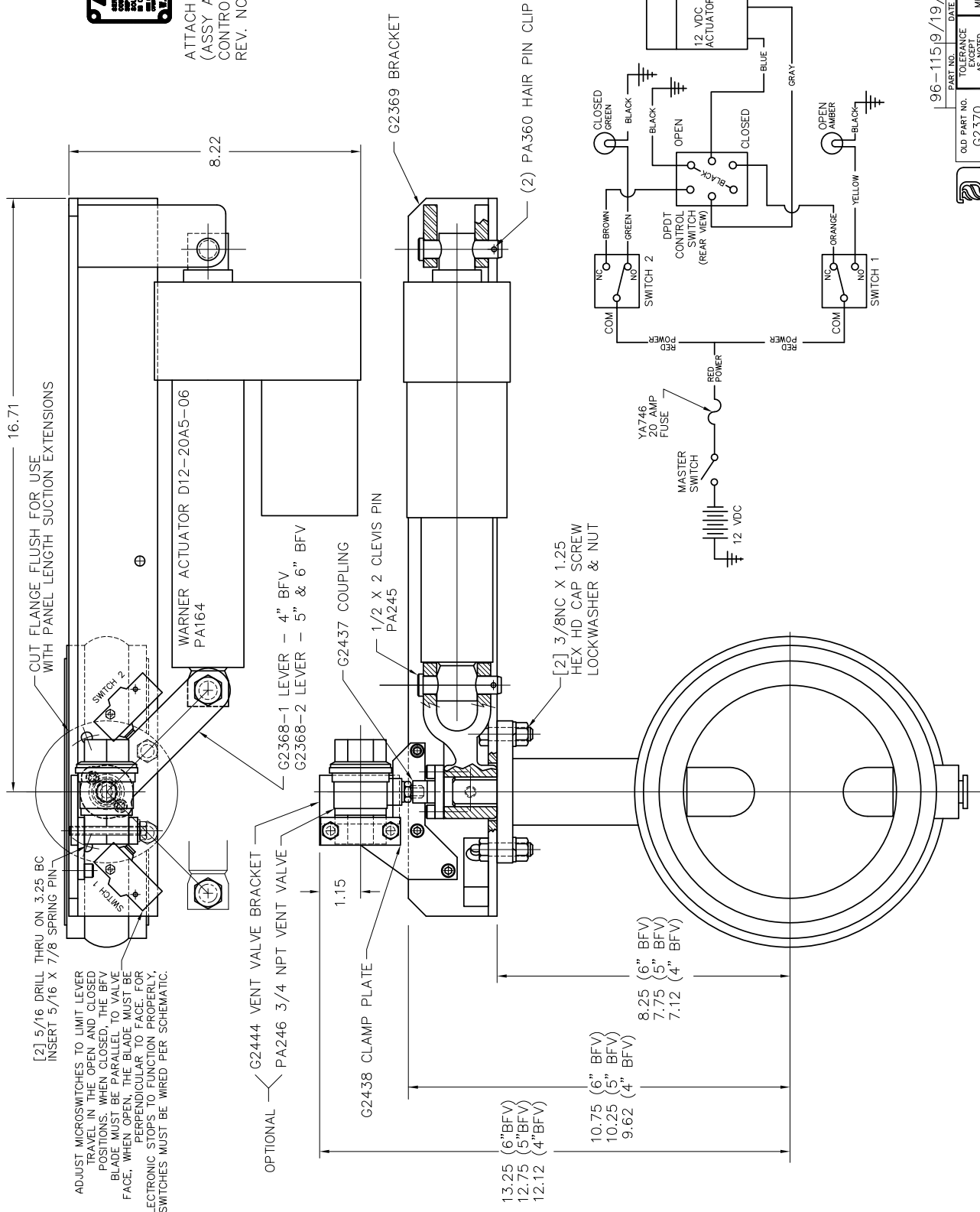

[2] 5/16 DRILL THRU ON 3.25 BC  
INSERT 5/16 X 7/8 SPRING PIN -  
CUT FLANGE FLUSH FOR USE  
WITH PANEL LENGTH SUCTION EXTENSIONS

ADJUST MICROSWITCHES TO LIMIT LEVER  
TRAVEL IN THE OPEN AND CLOSE  
POSITIONS. WHEN CLOSED, THE BEV  
BLADE MUST BE PARALLEL TO VALVE  
FACE. WHEN OPEN, THE BLADE MUST BE  
PERPENDICULAR TO FACE FOR  
ELECTRONIC STOPS TO FUNCTION PROPERLY.  
SWITCHES MUST BE WIRED PER SCHEMATIC.

OPTIONAL G2444 VENT VALVE BRACKET  
PA246 3/4 NPT VENT VALVE

13.25 (6" BFV)  
12.75 (5" BFV)  
12.12 (4" BFV)

10.75 (6" BFV)  
10.25 (5" BFV)  
9.62 (4" BFV)

8.25 (6" BFV)  
7.75 (5" BFV)  
7.12 (4" BFV)

APPROXIMATE WEIGHT = 35 LB = 15.9 KG (6" BFV)  
30 LB = 13.6 KG (5" BFV)  
27 LB = 12.2 KG (4" BFV)

96-115/9/96 © ADDED PLATE LMH

PART NO.	DATE	CHANGE
G2370		

OLD PART NO. G2370  
TOLERANCE UNLESS NOTED AS NOTED  
FRAC DIM ±.01  
DIM ±.005  
ANGLE ±1°

W.S. DARLEY & CO.  
MELROSE PARK, IL - CHIPPewa FALLS, WI  
DWG - BUTTERFLY VALVE ASSEMBLY  
ELECTRIC ACTUATED

DATE NOV20,91  
DRN SEITZ  
CHD TRCD  
SCALE 1/2

MATERIAL: DO NOT SCALE PRINT  
ALL DIMENSIONS IN INCHES UNLESS NOTED  
THIS DESIGN IS THE PROPERTY OF W.S. DARLEY AND CO. UNAUTHORIZED REPRODUCTION IS PROHIBITED

DGD0101

REVISIONS				
LTR	DESCRIPTION	DATE	CHG NO.	APPR'D
A	REVISED WIRING TO REFLECT HRNESS25FEB2009	06/22/10	5236	SMS
B	ADDED BUSHING, CLOSE NIPPLE, CHECK VALVE, AND NOTES TO MODEL AND DRAWING	06/22/10	6482	RJG

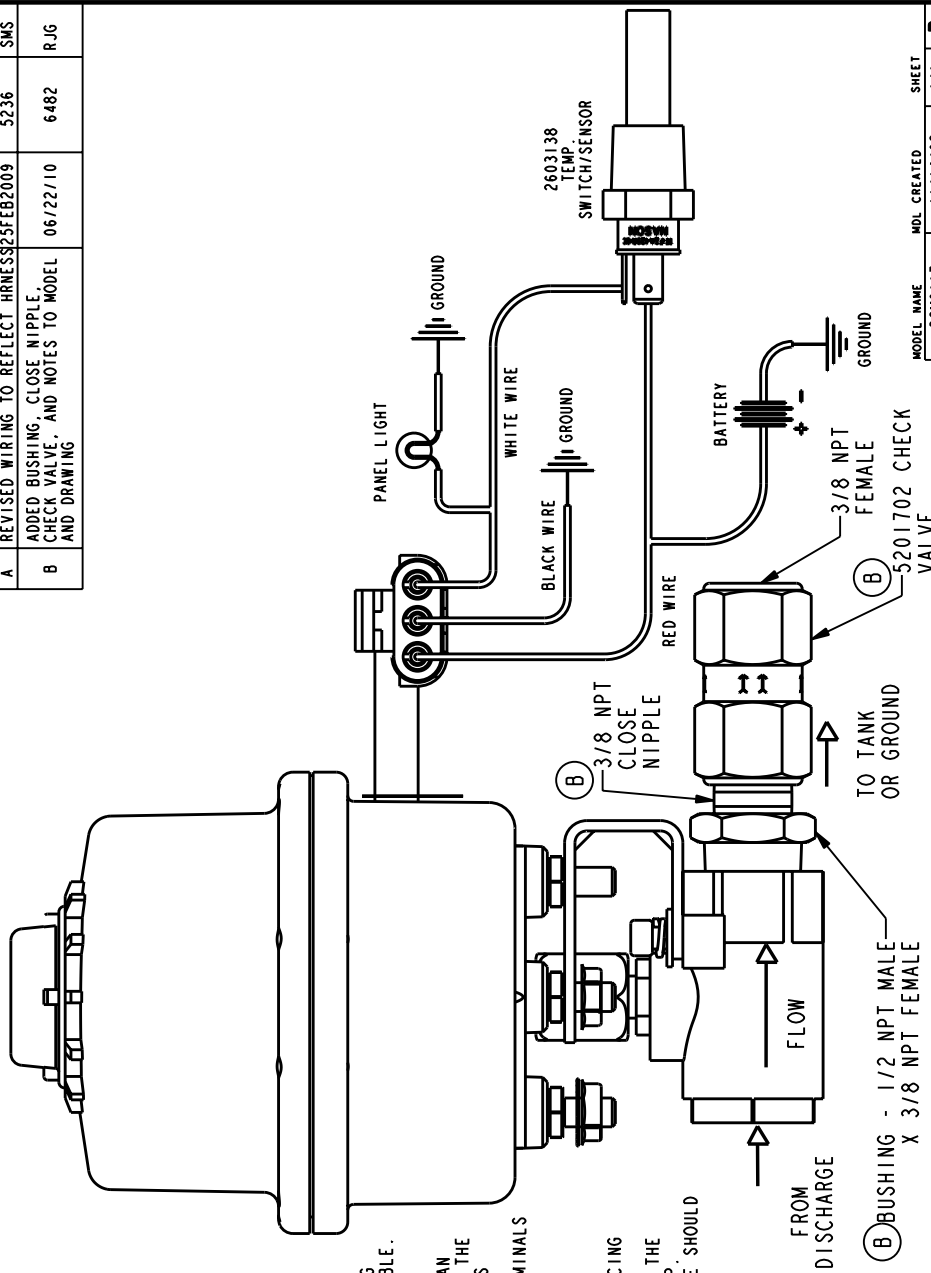

**INSTALLATION INSTRUCTIONS:**

- 1) INSTALL TEMPERATURE SWITCH ON SUCTION SIDE OF PUMP, AS NEAR TO IMPELLER AS POSSIBLE, PREFERABLY BETWEEN THE IMPELLER AND THE RELIEF VALVE.
  - 2) INSTALL THE ACTUATOR VALVE ON THE DISCHARGE SIDE OF THE PUMP. ITS LOCATION IS NOT CRITICAL. IT CAN BE MOUNTED DIRECTLY TO THE PUMP OR POSITIONED REMOTELY AND CONNECTED WITH A 3/8 OD MINIMUM LINE.
  - 3) VALVE DOES NOT NEED TO BE MOUNTED VERTICALLY AS SHOWN.
  - 4) \*PLUMB THE VALVE OUTLET TO TANK, IF DESIRED, USING 3/8 OD MINIMUM LINE. KEEP ALL LINES AS SHORT AS POSSIBLE.
  - 5) ATTACH ONE LEAD OF VALVE TO THE TERMINAL ON THE TEMPERATURE SWITCH. ATTACH THE OTHER LEAD TO A FUSED VOLTAGE SOURCE. IF DESIRED, THE TEMPERATURE SWITCH CAN ALSO BE USED TO CONTROL A LIGHT ON THE PANEL NOTIFYING THE OPERATOR THAT OVERHEATING IS OCCURRING AND THE UNIT HAS BEEN ACTIVATED.
  - 6) TO TEST THE VALVE: WITH PUMP RUNNING, JUMP THE TERMINALS ON THE TEMPERATURE SWITCH. IF THE VALVE DOES NOT DISCHARGE, IT MAY BE INSTALLED BACKWARDS OR WIRING CONNECTIONS MAY BE INCORRECT.
- \* CONNECTION TO TANK MAY CAUSE TANK TO OVERHEAT, REDUCING THE EFFECTIVENESS OF THIS DEVICE TO PREVENT FREEZING DAMAGE. WHEN CONNECTING TO TANK, THE VALVE SHOULD BE MOUNTED ON THE TANK, BUT ABOVE THE PUMP. IF THE VALVE IS TO DISCHARGE TO ATMOSPHERE, THE VALVE SHOULD BE MOUNTED ON, OR AS CLOSE TO THE PUMP AS POSSIBLE.

(B) BUSHING - 1/2 NPT MALE X 3/8 NPT FEMALE

REMOVE SHARP EDGES		INCH (MILLIMETER)		SHEET	
MATERIAL DESCRIPTION:		ALL DIMENSIONS IN INCHES UNLESS NOTED		SCALE	
THIS DESIGN IS THE PROPERTY OF W.S. DARLEY AND CO. UNAUTHORIZED REPRODUCTION IS PROHIBITED		DO NOT SCALE PRINT		DATE 14-NOV-08	
MATERIAL NO.		PATTERN NO.		DR'N: RJG	
TEMPERATURE SENSITIVE		OLD PART NO.		CHGD: DMS	
TOLERANCE EXCEPT AS NOTED .00 ± .03 ANGLES ±1°		5201702 CHECK VALVE		1/1	
W.S. Darley & Co. ITASCA, IL - CHIPPEWA FALLS, WI		MODEL NAME DGM0117		MDL CREATED 11/14/08	
DWG - THERMAL RELIEF SYSTEM KZCO VALVE, 2603138 TEMP. SENSOR		DGM0117		1/1	
DGM0117		11/14/08		1/1	
DGM0117		11/14/08		1/1	

REVISIONS

LTR	DESCRIPTION	DATE	CHG NO.	APPR'D

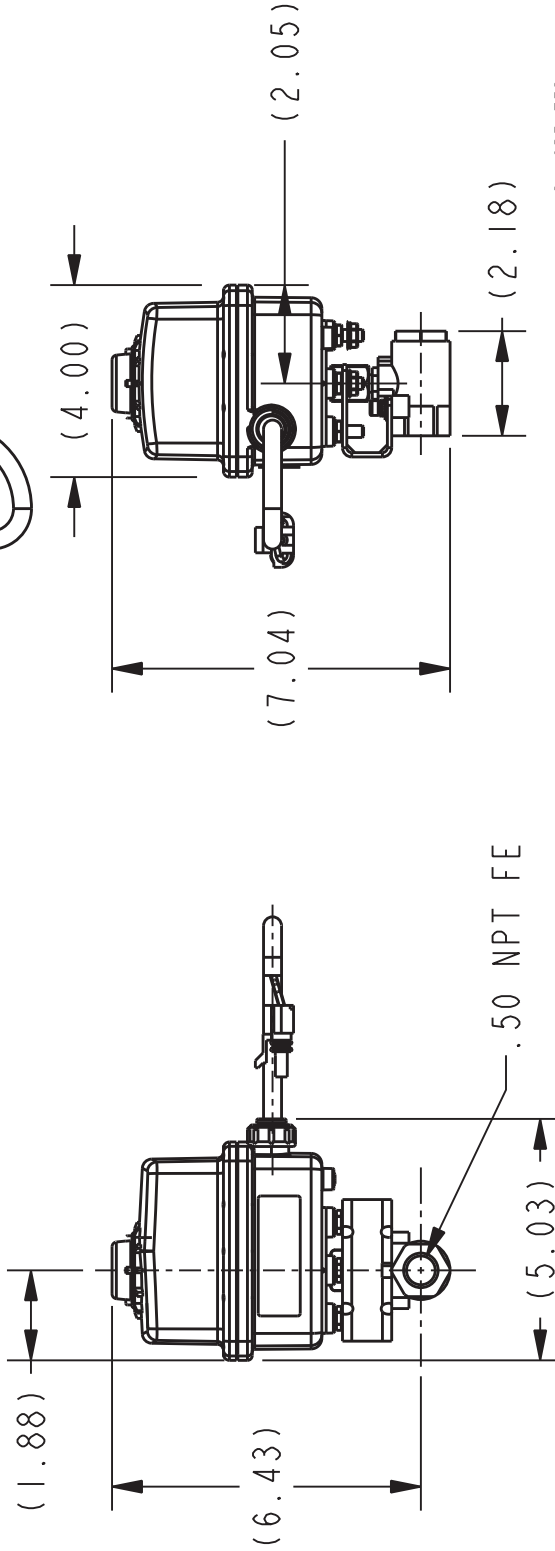
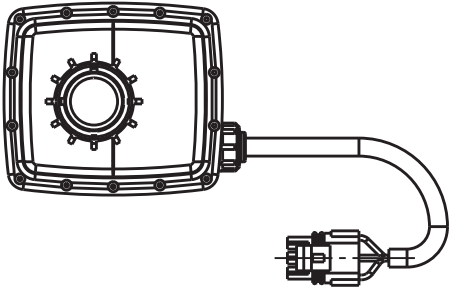
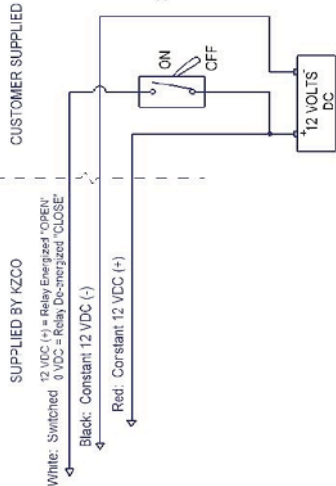

REMOVE SHARP EDGES		INCH [MILLIMETER]		THIRD ANGLE PROJECTION		OLD PART NO.		MODEL NAME		MDL CREATED		SHEET	
MATERIAL DESCRIPTION: KZCO 84D23-10D20-PO1								5209401		11/13/08		1/2	
THIS DESIGN IS THE PROPERTY OF W.S. DARLEY AND CO. - UNAUTHORIZED REPRODUCTION IS PROHIBITED		DO NOT SCALE PRINT		MATERIAL NO.		PATTERN NO.		TOLERANCE EXCEPT AS NOTED .00 ±.03 .000 ±.010 ANGLES ±°		W.S. Darley & Co. ITASCA, IL - CHIPPEWA FALLS, WI		VALVE - ACTUATED, 12VDC, .50NPT FE KZCO 84D23-10D20-PO1	
								DR 'N		R/JG		DATE 13-Nov-08	
								CHKD		DWS		SCALE 1/4	
								TRCD				5209401	

REVISED	RETURNED	REWORKED	7/7/5/2009 9:4 5:57 AM	REWORKED
-2-				by (initial)

INPUT/OUTPUT  
POWER = 1224 VDC  
1 - BLACK - POWER (-) NEGATIVE  
2 - RED - POWER (+) POSITIVE  
3 - WHITE - SIGNAL (+) POSITIVE TO OPEN  
4 -

DIP SWITCH



RED MOTOR LEAD  
TO RED DOT

PIN A - RED  
PIN B - BLACK  
PIN C - WHITE

SCALE .500

PROGRAM NOTE:

MAX30 SET DATA  
CONTROL INPUT = 1  
FEEDBACK = 0  
OPERATION = 0  
MOTOR = 0  
SPEED CT = 0.8  
ZEROCSET = 0.5  
RANGE TOLERANCE = 1  
ROTATION = 0032  
ACTUATOR RANGE = 0.00/0.00  
DESIGN VOLTAGE = E  
DIP SW = 3  
LABEL = K200  
OPTIONS = 0  
PLUS TYPE = P  
TEST PLUS =

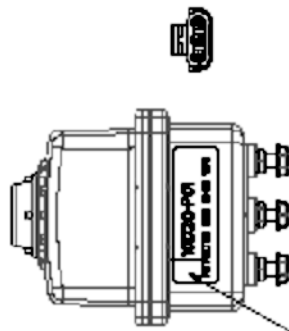
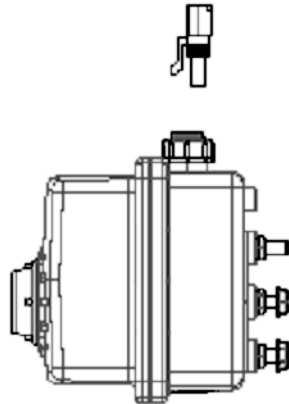

ACTUATOR LABEL  
MAX30 LABEL DESCRIPTION  
ACTUATOR, EHS 12/24 VDC

21	1	EH-502	LABEL, EH ACTUATOR, 2.9" X 1.1", THERMAL TRANSFER, WHITE	NO MATERIAL
20	1	800018	HARNESSES, BBA, 38T, WPS122.5"	
19	1	EH3-118-Y	PLUG, YELLOW	POLYPROPYLENE, IALC, 20
18	1	339-0079	PCB ASSY, EHS L1 SOLID STATE I2 VDC	
17	1	100-901	GEAR MOTOR, M2, 18 RPM/MIN/CM	NO MATERIAL
16	3	07-222	NUT, HEX HEAD, SEPARATED FLANGE, .250-20 UNC, .28	STAINLESS STEEL TYPE 300
15	4	EH3-136	STUD, 1/4-20 X 1/2 MTG	STAINLESS STEEL TYPE 300
14	1	EH-104	RETAINER, PUSH ON 5/16" SHAFT	STAINLESS STEEL TYPE 304
13	1	49-8100	CAM ASSY, EXTD LOBE FOR EHS E-OPT	NO MATERIAL
12	1	EH-502	LABEL, EH ACTUATOR, 2.9" X 1.1", THERMAL TRANSFER, WHITE	NO MATERIAL
11	1	EH-130	O-RING, DOME	POLYCARBONATE
10	1	EH3-114	DOME, CLEAR	STAINLESS STEEL TYPE 410
9	14	EHPT-1103	SCREW PAN, PHILLIPS, HIGH-LOW, 5-10 X .982	STAINLESS STEEL TYPE 18-8
8	1	EH3-100-1N	LID, CASE, EHS, DOME	FLUOROCARBON BLACK, 75 DURCOMETER
7	4	EH3-130	SCREW 4-22 X 1.24 PPHMS SS	STAINLESS STEEL TYPE 18-8
6	1	EH-137	SCREW 1/8-18 X .367 108 PPH SS	STAINLESS STEEL TYPE 18-8
5	1	EH3-1030	O-RING, EHS, CASE, I.D. # 120	FLUOROCARBON BLACK, 75 DURCOMETER
4	1	EHPT-1108	O-RING, #108, PRESSURE TEST POINT	FLUOROCARBON BLACK, 75 DURCOMETER
3	1	EHPT-140	O-RING, #112, MOTOR SHAFT, VITON	FLUOROCARBON BLACK, 75 DURCOMETER
2	1	EH3-10034N	LOWER CASE - EHS INTERNAL, MTG	NYLON 6/6, 100-1 BLACK
1	1	419-0012	CASE KIT, EHS IM DOME NYLON M2 MTR	NYLON 6/6, 100-1 BLACK
EH101		PART NUMBER		USP3AL

**KZCO INC.**  
2008 STANLEY  
2000 WOODMAN RD  
P.O. BOX 100  
MARIETTA, GA 30067

REV: 2.008-05-29  
DESIGNED: EROKAMP  
DRAWN: F.EDGE  
REVISED: A. KOTTAS  
SCALE: 500  
PART NO: 100204P01  
DATE: 10/22/09

FIGURE 1  
TOP VIEW  
LEFT SIDE VIEW  
RIGHT SIDE VIEW  
FRONT VIEW  
REAR VIEW  
ISOMETRIC VIEW

REV: 2.008-05-29  
DESIGNED: EROKAMP  
DRAWN: F.EDGE  
REVISED: A. KOTTAS  
SCALE: 500  
PART NO: 100204P01  
DATE: 10/22/09

REVISIONS

LTR	DESCRIPTION	DATE	CHG NO.	APPR'D

**60AD WIRING**  
Standard On/Off applications, SPST Switch  
24 VDC

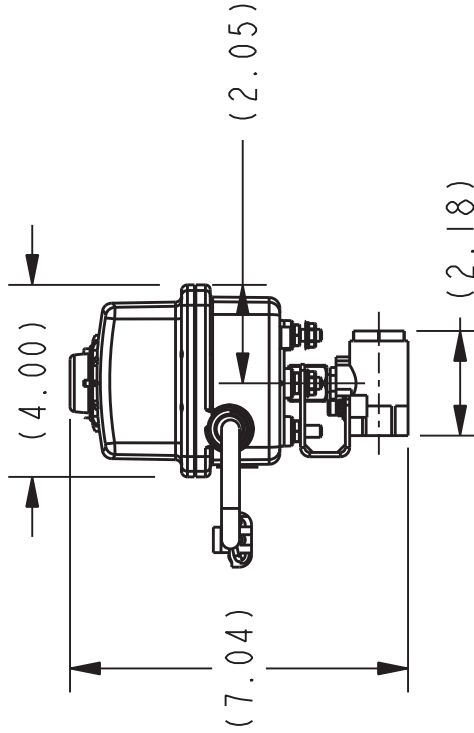
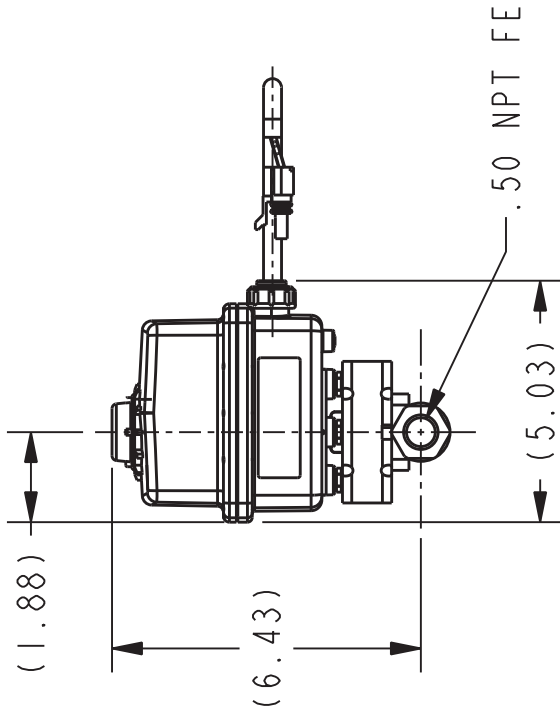
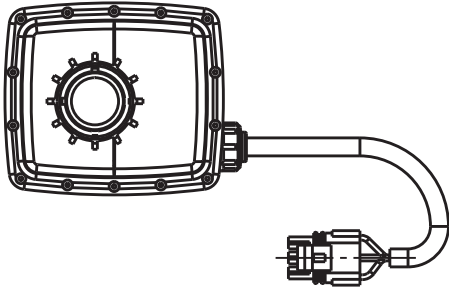
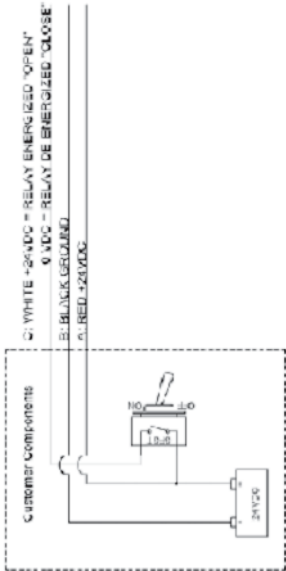

**REMOVE SHARP EDGES**

INCH  
[MILLIMETER]



OLD PART NO.

TOLERANCE  
EXCEPT  
AS NOTED

MODEL NAME 5209402 MDL CREATED 11/13/08 SHEET 1/3 A

MATERIAL DESCRIPTION:  
KZCO 84D23-60AD-M

MATERIAL NO.

DR 'N RUG  
CHKD DWS  
TRCD

**W.S. Darley & Co.**  
ITASCA, IL - CHIPPEWA FALLS, WI  
VALVE - ACTUATED, 24VDC, .50NPT FE  
KZCO 84D23-60AD-M

THIS DESIGN IS THE PROPERTY OF  
W.S. DARLEY AND CO. - UNAUTHORIZED  
REPRODUCTION IS PROHIBITED

DO NOT SCALE PRINT

DATE 13-Nov-08  
SCALE 1/4

**5209402**

REVISION REV. 1	REVISION ECD:	REVISION/REVISION DATE 3/28/2008 1:49:38 PM	REVISION/REVISION BY wFedde
--------------------	---------------	--	--------------------------------

MOTOR LEADS  
RED TO RED DOT

PCB PINOUT  
1 - RED  
2 - WHITE  
3 - BLACK

PIN A - RED  
PIN B - BLACK  
PIN C - WHITE

SCALE .500

MAS60 SET DATA  
 CONTROL INPUT = 1  
 FEEDBACK = 0  
 OPERATION = 0  
 MOTOR = M  
 SPEED CT = 0.8  
 ZEROSET = 136  
 RANGE TOLERANCE = 1  
 ROTATION = C0081  
 ACTUATOR RANGE = 0.000.00  
 DESIGN VOLTAGE = D  
 DIP SX =  
 LABEL = KZCO  
 OPTIONS = 0  
 PLUG TYPE =  
 TEST PLUG =

  

-ALL DIMENSIONS IN INCHES UNLESS OTHERWISE SPECIFIED-	DATE: 2007-04-16	DESIGNED: L. ERDKAMP	DRAWN: W. FEDDE	APPROVED: A. KOTTAS	TITLE: ACTUATOR, EH3_3S@24VDC
TOTAL HOLE DIA. 0.05 IN CORNER BREAK: 0.010 IN SURFACE FINISH: RA0.8	DIMENSIONS: 0.125 IN X 0.125 IN X 0.125 IN	DIMENSIONS: 0.125 IN X 0.125 IN X 0.125 IN	DIMENSIONS: 0.125 IN X 0.125 IN X 0.125 IN	DIMENSIONS: 0.125 IN X 0.125 IN X 0.125 IN	DIMENSIONS: 0.125 IN X 0.125 IN X 0.125 IN
SURF AREA: 93.793 SQ IN VOLUME: 12.500 CU IN	SCALE: .500	SIZE: B	PART NO: 000-60AD-M	MATERIAL:	SHEET: 1 OF 1

  

QTY	PART NUMBER	DESCRIPTION	MATERIAL
8	1	EH-502	NO_MATERIAL
7	2	QX-222	STAINLESS_STEEL_TYPE_303
6	4	EH3-135	STAINLESS_STEEL_TYPE_303
5	1	800018	POLYPROPYLENE_TALC_20
4	1	EH3-115-Y	FLAG_YELLOW
3	1	800488	PCB ASSY_EH3 24VDC 60AD/60DF
2	1	EH3-110	GEAR MOTOR_EH3 SERIES M1 18 RPM @ 12VDC
1	1	498-0005	CASE KIT_EH3 M DOME NYLON M1 & M1 MTR

REVISION	REVISED BY	REVISION/REVISION DATE	REVISION/REVISION BY
-6-	REVISED BY	8/12/2008 9:18:50 AM	egotschal

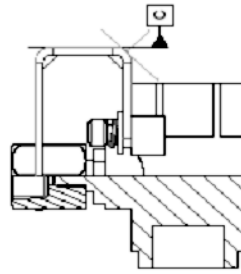
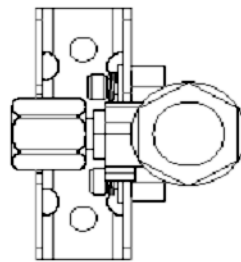
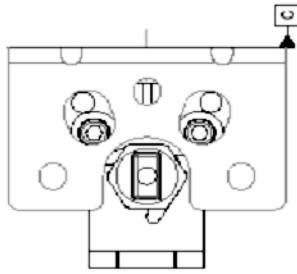

SECTION A-A

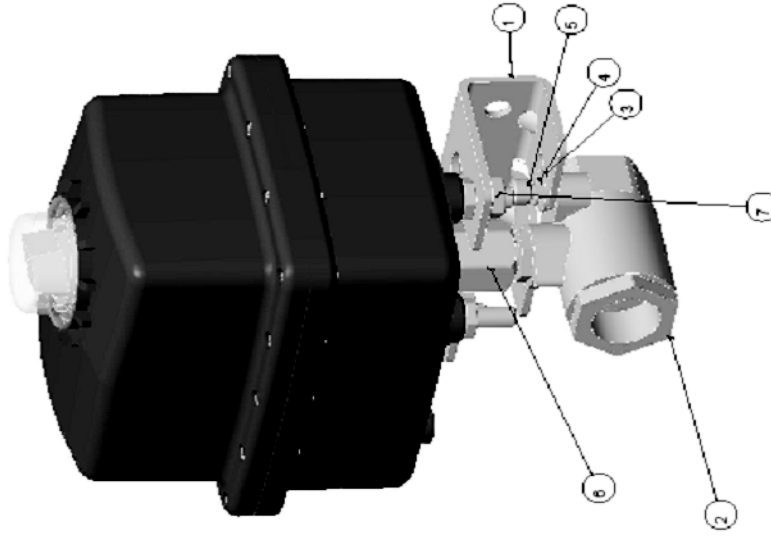

ACTUATOR SHOWN IS REPRESENTATIVE USED  
 ONLY TO SHOW PROPER ORIENTATION TO VALVE.

QTY	PART NUMBER	DESCRIPTION	MATERIAL
7	QK-222	NUT, HEX HEAD, SERRATED FLANGE, .250-20 UNC-2B	STAINLESS STEEL TYPE 303
6	EH-145	COUPLER, 1/4" ~ 1/2" APOLLO	STAINLESS STEEL TYPE 316
5	EH-158	SCREW, #10-24 X 3/8" SS SOCKET HEAD	STAINLESS STEEL TYPE 303 OR 316
4	BHPT-103	WASHER, LOCK, 1/16" ID X .334 OD X .047 T	STAINLESS STEEL TYPE 316
3	BHPT-150	WASHER, FLAT, #10 19-8 SS	STAINLESS STEEL TYPE 316
2	EH3-040	VALVE, 1/2" 2 WAY APOLLO 70-103-01 BRONZE BALL VALVE	BRONZE
1	EH3-174	BRACKET, MOUNTING EH3 SERIES	STAINLESS STEEL TYPE 304
DET	QTY	PART NUMBER	DESCRIPTION

STANDARD TOLERANCES - ALL DIMENSIONS IN INCHES UNLESS NOTED	DATE: 2007-09-08	DESIGNED: L. ERDKAMP	2180 1/2 PARKWAY GREENHACK, NE 8338 USA TEL: 407-334-1200 FAX: 407-334-1202
TOTAL POINTS FOR SURFACE FINISH: 30X.01 30X.05 30X.11	DESIGNED: L. ERDKAMP	DRAWN: C. HOWARD	KZCO INC.
APPROVED: L. ERDKAMP	APPROVED: L. ERDKAMP	APPROVED: L. ERDKAMP	
DENSITY: 260 LBS/CU IN SURF AREA: 42.83 SQ IN VOLUME: 12.15 CU IN	SCALE: .750	SIZE: B	TITLE: VALVE KIT, EH3 OFFSET MTG 1/2" 2-PC BRZ
			REV: 1
			PART NO: 84D23
			DRAWING NO: 84D23