

# W.S. DARLEY & CO.

## REPAIR SERVICE INSTRUCTIONS TYPE 1 1/4 AGE PORTABLE PUMP

### PUMP DISASSEMBLY FOR OVERHAUL Refer to Drawing DAC0300

1. Remove four 3/5" NC nuts and remove discharge heard (48) from pump casing (40). Discard gasket (49).
2. Remove eight 5/16" NC nuts and remove outboard head (59) from pump casing. Discard gasket (51).
3. Remove cotter key (53), impeller nut (41), and impeller washer (20).
4. Slide impeller (54) off impeller shaft (45). (It may be necessary to complete Step 5 and tap impeller and pump casing (40) off impeller shaft together.)
5. Remove four 5/16" NC nuts and slide pump casing (40) off impeller shaft (45) and away from gear case (21).
6. Slide water slinger (69) off impeller shaft (45).
7. Remove gland yoke (63) from pump casing (40).
8. If necessary to replace, press seal ring (52) out of outboard head (59).
9. If necessary to replace, press stuffing box (66) out of pump casing (40).
10. Remove nine 1/4" NC cap screws and separate gear case (21) and motor adapter (57). Slide gear case off impeller shaft (45). It may be necessary to tap impeller shaft out of gear case.
11. Press oil seal (27) out of gear case (21).
12. Remove gear retaining screw (50) and gear retaining washer (55).
13. Pull drive gear (26) off drive shaft with a suitable puller.
14. Pull impeller shaft (45) assembly out of motor adapter (57).
15. Press bearing (24) and pinion gear (25) off the impeller shaft (45) together.
16. Press bearing (24) off the impeller shaft (45).
17. Remove socket head cap screws and remove motor adapter (57) from engine flange.
18. Press oil seal (70) out of the motor adapter (57). Some models do not have an oil seal in the motor adapter.

### PARTS INSPECTION AND MEASUREMENT

1. Clean all parts and examine carefully for wear or deterioration. Replace any questionable parts.
2. Measure the impeller seal rings, seal ring for wear. Use the following table for comparison:

Impeller Seal Ring O.D.	1.3050 - 1.3070"
Seal Ring	1.3140 - 1.3160"
Clearance - original	0.0070 - 0.0110"

3. If clearance exceeds 0.025" on diameter, impeller seal rings can be restored to original size by soldering a ring over trued surface which retains at least 0.090" wall thickness. Stationary seal rings should also be replaced.

/

4. Measure impeller shaft and stuffing boxes for wear. Use the following table for comparison.

Impeller Shaft diameter at packing area	0.748 - 0.749"
Stuffing Box bore - new	0.753 - 0.754"
Stuffing Box bore - maximum	0.759"
Clearance - original	0.004 - 0.006"
Clearance - maximum allowable	0.011"

5. Measure bearing housing bores for proper size. Use the following table for comparison. If any bore exceeds the high limit by 0.0005", the part should be replaced.

<b>PART</b>	<b>REP NO.</b>	<b>ORIGINAL BORE DIA.</b>
Gear Case	21	2.0472 - 2.0479"
Motor Adapter	57	2.0472 - 2.0479"

6. Measure shaft bearing journals for proper size. Use the following table for comparison. The low limit under bearing is required to ensure a press fit with inner bearing race.

<b>PART</b>	<b>REP NO.</b>	<b>ORIGINAL JOURNAL DIA.</b>
Impeller Shaft	45	0.7875 - 0.7879"
	center end	0.7875 - 0.7879"

7. The original impeller shaft diameter under the pinion gear is 0.8123 to 0.8128". The original pinion gear bore is 0.8123 to 0.8128" providing 0.0005" press fit to 0.0005" clearance. The parts are still serviceable up to 0.0010" clearance. The pinion gear may be reversed to work the other side of the gear teeth.

### **ASSEMBLY OF TYPE 1 1/4 AGE PUMP AND TRANSMISSION**

**Refer to Drawing DAC0300**

1. Press oil seal (70) into motor adapter (57) with lip spring of seal facing toward gear. Some models do not have oil seal (70).
2. Slide motor adapter (57) over drive shaft. Apply Loctite 243 or equivalent to the threads of the socket head cap screws used to attach motor adapter to engine flange.
3. Apply light coating of grease to impeller shaft (45). Place the pinion gear key (22) in the impeller shaft keyway, align with key slot in pinion gear (25) and press shaft evenly into pinion gear bore until shaft shoulder is tight against side of gear.
4. Apply a thin coating of grease to bore of bearing (24) and press bearing onto impeller shaft (45) until inner race is tight against shaft shoulder.
5. Apply a thin coating of grease to bore of bearing (24) and press bearing onto impeller shaft (45) until bearing and pinion gear are tight together.
6. Tap drive gear (26) onto drive shaft half-way. Apply grease to bearing bore of motor adapter (57) and slide impeller shaft (45) assembly into position in motor adapter (57), making sure bearing (24) is in its pocket. Finish tapping drive gear onto shaft.
7. Attach gear retaining washer (55) to engine shaft with gear retaining screw (50) and lock washer (19).
8. Place gasket (44) into position on motor adapter (57).

/

9. Slide gear case (21) over impeller shaft (45) and tap into position on bearing (24). Attach to motor adapter (57) with nine 1/4" NC x 3/4" hex head cap screws with red Loctite and flat washers. Torque to 72 in-lbs.
10. Apply oil to impeller shaft (45) and slide oil seal (27) over impeller shaft with lip spring of seal facing toward gear. Tap into gear case (21) with a driver sleeve.
11. Slide water slinger (69) onto impeller shaft (45) until metal is just visible between water slinger and packing area of shaft.
12. Apply a coating of Loctite 603 (or equivalent) to the outer surface of the stuffing box (66). Align packing holes in stuffing box (66) with holes in pump casing (40) and press stuffing box into pump casing until seated.
13. Slide pump casing (40) onto impeller shaft (45), and attach with four 5/16" NC nuts and lock washers on studs.
14. Slide impeller (54) and impeller washer (20) onto impeller shaft (45).
15. Clean and dry shaft thread and impeller nut (41), removing dirt, grease, and oil. (Loctite Klean N' Prime Part No. 2556 (or equivalent) should be used.)
16. Apply Loctite 243 Threadlocker (or equivalent) to impeller shaft and nut threads.
17. Tighten impeller nut (41) until it contacts impeller washer (20), then turn to next cotter key hole. DO NOT OVER TIGHTEN.
18. Open a 3/32" x 3/4" STAINLESS STEEL cotter key and insert one leg into impeller shaft cotter key hole. Bend around end of shaft and cut off the extra.
19. Press seal ring (52) into outboard head (59) with bevel edge inserted first.
20. Place gasket (51) on outboard head (59). Tap outboard head into place on pump casing (40). Attach outboard head to pump casing with eight 5/16" NC nuts on studs.
21. Fill stuffing box with packing and replace gland yoke (63).
22. Place discharge head gasket (49) into position on discharge head (48). Attach discharge head to pump casing (40) with four 3/8" NC nuts on studs.
23. Fill gear case with SAE80W/90 gear lube oil - NOT GREASE - to the level of the 1/8" oil level plug.

## **LUBRICATION**

Check the pump oil level every 25 hours, and keep the gear case filled with oil to the level of the oil-level plug.

Drain the oil every 50 hours or every 6 month, which ever comes first. Refill the gear case with SAE80W/90 gear lube oil.

Check and change the engine oil and filter according to the engine manufacturers recommendations.

IF FURTHER INFORMATION IS NEEDED, CALL **W.S. DARLEY & CO.** AT CHIPPEWA  
FALLS, WI. AT 800-634-7812 or 715-726-2650

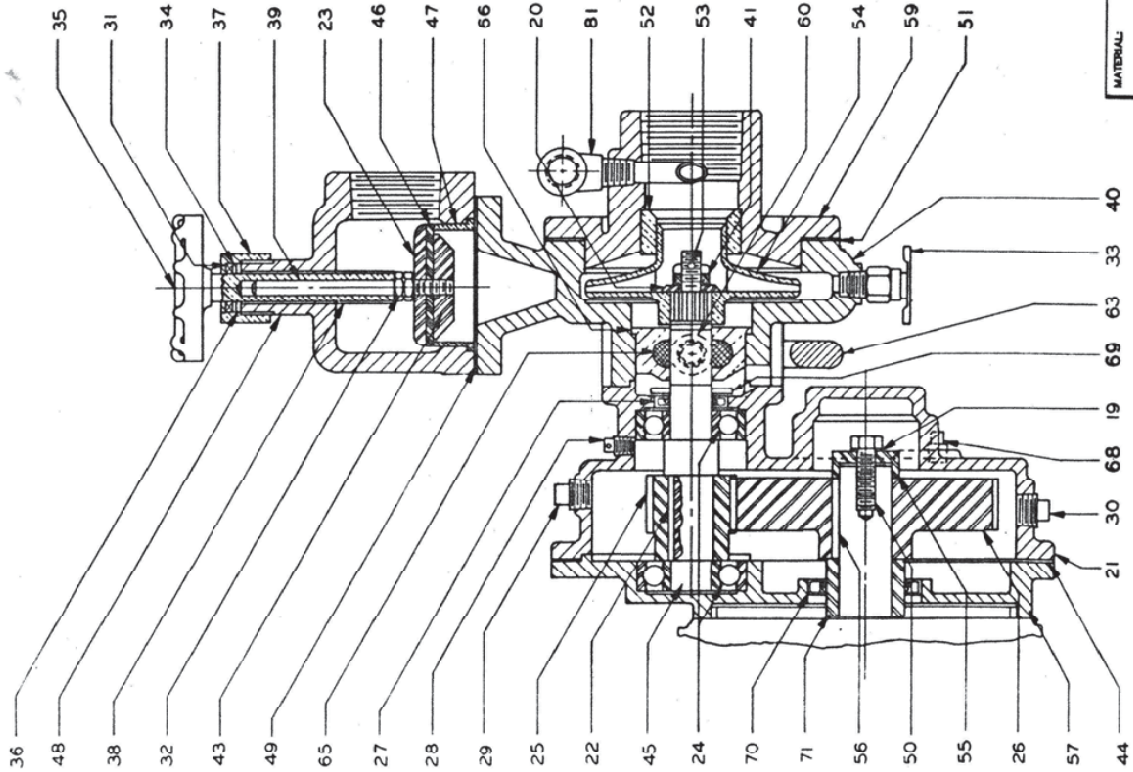

NO.	NAME OF PART	NO.	NAME OF PART
19	LOCKWASHER	44	GEAR CASE GASKET
20	IMPELLER WASHER	45	IMPELLER SHAFT
21	GEARCASE	46	CHECK VALVE RUBBER
22	PINION KEY	47	CHECK VALVE SEAT
23	CHECK VALVE PLATE	48	DISCHARGE HEAD
24	BEARINGS	49	DISCHARGE HEAD GASKET
25	PINION GEAR	50	GEAR RETAINING SCREW
26	DRIVE GEAR	51	PUMP CASING GASKET
27	OIL SEAL	52	IMPELLER SEAL RING
28	VENT PLUG	53	COTTER KEY
29	OIL FILL PLUG	54	IMPELLER
30	OIL DRAIN PLUG	55	GEAR RETAINING WASHER
31	VALVE STEM PACKING	56	DRIVE GEAR KEY
32	JAM NUTS	57	MOTOR ADAPTER
33	DRAIN COCK	59	OUTBOARD HEAD
34	STUFFING BOX WASHER	60	PACKING PLUNGER SCREW
35	HANDWHEEL	63	GLAND YOKE
36	STUFFING BOX GASKET	65	PACKING
37	GLAND NUT	66	PACKING BOX
38	VALVE STEM	68	OIL LEVEL PLUG
39	CHECK VALVE STEM	69	WATER SLINGER
40	PUMP CASING	70	OIL SEAL
41	IMPELLER NUT	71	GEAR SPACER
43	CHECK VALVE DIFFUSER	81	PRIMER SUCTION FITTING

OK



OLD PART NO.  
A598

PART NO.	DATE	CHANGE
TOLERANCE FINISH AS NOTED	W.S. DARLEY & CO.	
FRAC 0M 2-01	MELROSE PARK, IL - CHIPPEWA FALLS, W	
000 2-08	DWG - 1-1/4 AGE ASSEMBLY	
ANGLES 31°	CROSS SECTION	
DRN S. LEE	DATE JAN05,89	SCALE 1/2
CHKD		DAC0300
TRCD		

MATERIAL

THIS DESIGN IS THE PROPERTY OF  
W.S. DARLEY & CO. - UNAUTHORIZED  
REPRODUCTION IS PROHIBITED

ALL DIMENSIONS IN  
INCHES UNLESS NOTED

DO NOT SCALE PRINT



## W. S. DARLEY & CO.

### DARLEY INJECTION TYPE STUFFING BOX ADJUSTMENT

**⚠ Prop 65 Warning:** This product contains lead, a chemical known to the State of California to cause cancer, birth defects, and other reproductive harm. Wash hands after handling.

**⚠ Caution:** Do not attempt to use anything but Darley injection packing. Using the wrong packing material in your pump may cause catastrophic failure of the pump shaft sealing components.

Only use W.S. Darley & Co.'s plastallic injection packing material. It is made of a special composition of shredded fibers, and a special bonding and lubricating compound.

It is important that the stuffing box is completely filled solid with packing and compressed firm during adjustment to prevent formation of voids and excessive leakage.

To pack the stuffing box when empty and assembled in the pump, remove the packing screw and nut assembly, and insert pellet form packing into the packing plunger guide. Replace the packing screw assembly and use a hand speed wrench to force the pellets into the gland. **DO NOT USE A POWER TOOL!** Repeat pellet additions while turning the impeller shaft by hand until resistance to turning is felt when the stuffing box is almost full. Continue turning packing screw by hand using a standard 6" long 9/16" end wrench until 4 lb. of force is felt at the end of the wrench. This is equivalent to 2 ft-lb or 24 in-lb torque. Continue turning until a few flakes of packing are extruded out the opening between the impeller shaft and the stuffing box hole. The gland is now ready for pressure testing or pumping.

After priming the pump with water, start the pump and raise the discharge pressure to 50 psi. Tighten the packing screw using a 6" long 9/16" end wrench until 4 lb. force is felt at the end of the wrench (24 in-lb torque). Continue operating the pump at 50 psi for 5 minutes to dissipate packing pressure against the shaft and permit cooling water to flow between the shaft and stuffing box hole. Make sure that water actually does come through before operating pump at any higher pressure. The normal drip rate may vary between 5 and 60 drops per minute.

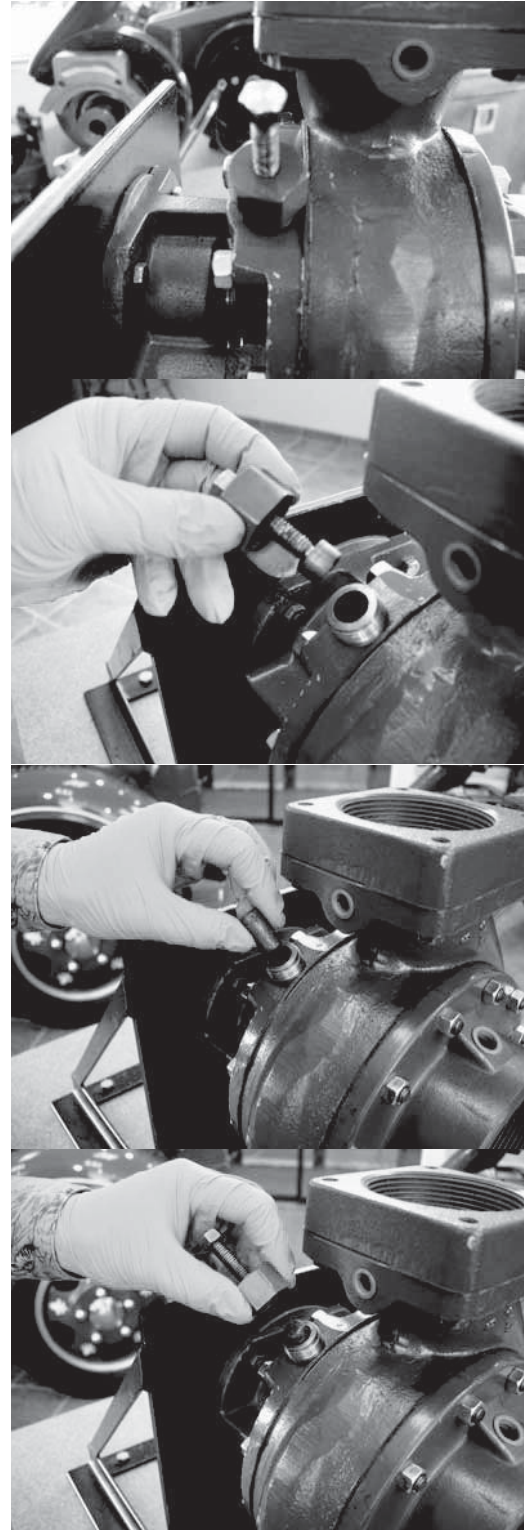

Operate the pump for 10 minutes at the highest normal operating pressure flowing sufficient water to prevent overheating. Do not run the pump blocked tight. Lower discharge pressure to 50 psi and repeat the packing screw tightening procedure outlined above.

The pump may now be operated for any time period required within its rated capacity. However, the drip rate should be monitored more frequently during the first few hours, and adjusted if necessary to achieve a stable flow rate. Several more adjustments may be required.



For a list of approximate quantity of packing pellets required by model (completely repacked), see below:

Model	Approximate # Packing Pellets
A	6
2BE	6
EM	15
H	8
JM	8
KD	10
KS	8
LD	15
LS	9
P	10
U2	5
U4	10

If further information is needed, call **W.S. DARLEY & CO.**  
at Chippewa Falls, WI. at 800-634-7812 or 715-726-2650



## **W. S. DARLEY & CO.**

### **DARLEY INJECTION TYPE STUFFING BOX ADJUSTMENT AGE, YOKE STYLE**

Only use Garlock style #926-AFP plastallic packing material. It is made of shredded composition lead foil, non-asbestos fibers, and a special bonding compound containing lubricant and graphite. W. S. Darley compresses this material into 5/8" dia. x 1" long pellets which are packed 23 to a box. It is Darley part no. 3817101. (Note: For this style of injection packing, the packing pellets must be rolled between your fingers to make them fit the 1/2" diameter holes.)

It is important that the stuffing box is completely filled solid with packing and compressed firm during adjustment to prevent formation of voids and excessive leakage.

To pack the stuffing box when empty and assembled in the pump, remove the packing screw and yoke assembly. Insert pellet form packing into the packing plunger guide hole, and force into the packing chamber with a 7/16" diameter rod. Repeat this in the same packing plunger guide hole until packing starts coming out the packing plunger guide hole on the side opposite the hole the packing is being forced in through. Place enough packing in each plunger guide hole to fill it to the top of the hole. Replace the packing screw assembly and force the pellets into the gland by turning the two thumb knobs with equal force while turning the impeller shaft by hand until resistance to turning is felt when the stuffing box is almost full. Continue turning packing screws until a few flakes of packing are extruded out the opening between the impeller shaft and the stuffing box hole. The gland is now ready for pressure testing or pumping.

After priming the pump with water, start the pump and raise the discharge pressure to 50 psi. Tighten the packing screw while operating the pump at 50 psi for 5 minutes to dissipate packing pressure against the shaft and permit cooling water to flow between the shaft and stuffing box hole. Make sure that water actually does come through before operating pump at any higher pressure. The normal drip rate may vary between 5 and 60 drops per minute.

Operate the pump for 10 minutes at the highest normal operating pressure flowing sufficient water to prevent overheating. Do not run pump blocked tight. Lower discharge pressure to 50 psi. and repeat the packing screw tightening procedure outlined above.

The pump may now be operated for any time period required within its rated capacity. However, the drip rate should be monitored more frequently during the first few hours, and adjusted if necessary to achieve a stable flow rate. Several more adjustments may be required.

**IF FURTHER INFORMATION IS NEEDED, CALL W.S. DARLEY & CO.**  
AT CHIPPEWA FALLS, WI. AT 800-634-7812 or 715-726-2650

## **Mechanical Shaft Seal**

This pump assembly incorporates high quality mechanical shaft seal(s) separating the pump housing components from atmosphere. Depending on the pump design, there may be one or two seals on each impeller shaft.

The seal size, design type, component materials, and housing configuration have been specifically designed for this pump application and rated operating parameters.

## **Mechanical Seal Basics**

A mechanical seal is a device that houses two highly polished components (known as faces). One face rotates, the other is stationary. A secondary elastomer bellows seals the primary ring to the shaft. An o-ring or cup seal seals the mating ring in the housing. The polished seal faces of the primary and mating rings are pressed together by a spring mechanism to provide adequate force to affect a seal. The force acting between the seal faces increases in direct proportion to product pressure.

The elastomer bellows seal utilized in this pump has the following design features:

- Mechanical drive of the primary seal ring. The drive band's notch design eliminates overstressing the elastomer sealing bellows.
- Bellows design provides automatic compensation for shaft endplay, run out, and primary ring wear.
- Seal face contact pressure is controlled by a single, non-clogging coil spring. This coil spring has been custom welded per Darley specifications to eliminate high-speed spring distortion.

The seal housing is designed and ported to provide optimal water flow and pressure assuring proper cooling and flushing of the seal components.

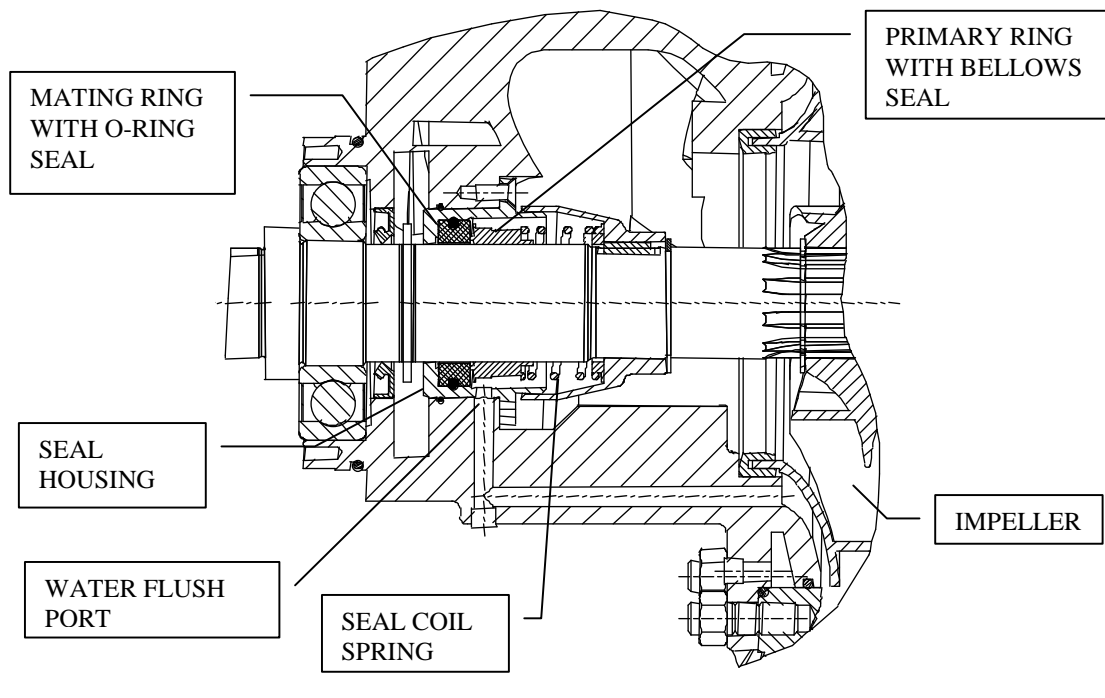



## **Operation and Maintenance**

When operated within rated operating conditions of this pump, these seals will provide trouble free service for extended periods.

Properly selected and applied mechanical shaft seals are leak free and require no adjustment. Should the seal area develop a leak, investigate the cause as soon as possible. Seal failure, leakage, may be the result of; worn seal faces, leaking bellows, or damaged o-rings. These failures may be attributed to bearing failure, impeller blockage, impeller imbalance, seal housing contamination, operating beyond pump design rating, or dry running,

Mechanical shaft seal design relies on the sealed media, in this case, water, to cool and lubricate the sealing surfaces. Therefore, extended dry operation may cause overheating and scoring or damage to the sealing surfaces, resulting in excessive leakage or a much shortened seal life.

To maximize seal life, minimize operation at pump pressures higher than pump rating. While operating at pressures beyond rating will not immediately damage the seal, it will increase sealing surface wear rate.



**CAUTION:** DO NOT RUN THE PUMP DRY EXCEPT MOMENTARILY AND AT LOW SPEEDS



**CAUTION:** DO NOT USE THIS PUMP FOR HOSE TESTING



**CAUTION:** THE MECHANICAL SEAL SHOULD NOT BE RUN DRY, WHILE THE PUMP IS NOT ENTRAINED WITH WATER, FOR A PERIOD LONGER THAN 2 MINUTES. FAILURE TO FOLLOW THIS RECOMMENDATION WILL LEAD TO PREMATURE WEAR AND FAILURE OF YOUR MECHANICAL SHAFT SEAL.



# DARLEY

## INSTALLATION OF MECHANICAL FACE SEAL WITH O’RING

### SPECIAL HANDLING

Study the engineering layout before installing the seal. This shaft seal is a precision product and should be handled and treated with care. Take special care to prevent scratches on the lapped faces of the primary and mating ring. Provide a very clean work area where the assembly will take place. Clean hands prior to assembly.

### INSTRUCTION STEPS:

#### Instructions for Installing a Mechanical Shaft Seal

1. Inspect mating ring pocket in seal housing ensuring it is clean, free of chips, and nick free, to provide a proper sealing surface. Isopropyl alcohol may be used to clean the surfaces if required.

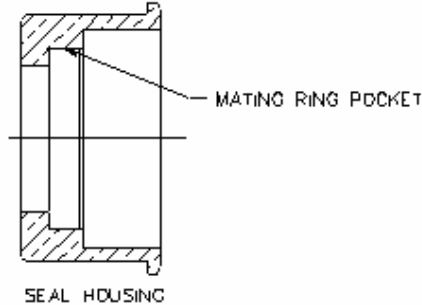

2. Inspect the pump shaft surface under the bellows, ensuring it is clean and nick free to provide a proper sealing surface. Isopropyl alcohol may be used to clean surface if required.

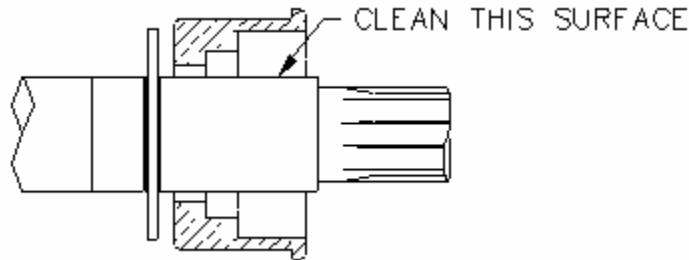

3. Lightly lubricate the o-ring on the mating ring with a single drop of P-80 water soluble rubber lubricant (do not over lubricate) and push it into the cavity using the recommended installation tool or other suitable plastic tube free of contaminants, firmly seating the mating ring square.

Note: The polished face of the mating ring must face out – away from the pump’s gear case. Try to not touch the polished sealing face with your fingers; the oils from your fingerprint can cause the seal to leak. Remove any P-80 from the sealing face after installation.

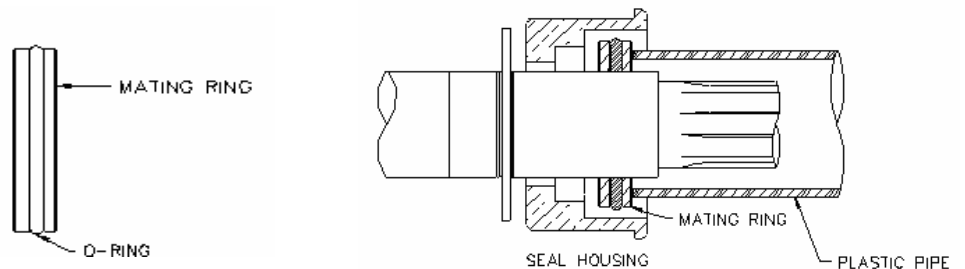
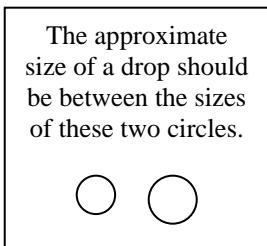

4. Clean the mating ring surface with isopropyl alcohol to remove any fingerprints and any other contaminants left on mating ring.

Note: Steps 5 – 9 need to all be completed with in 15 minutes or less.

5. Apply a small drop of P-80 rubber lubricant or water-soluble lubricant (not soapy water) to the inside diameter of the bellows assembly allowing it to be pushed easily into position.
6. Clean the polished sealing face of the primary ring with a clean lint free rag with isopropyl alcohol to remove all fingerprints and other contaminants.
7. Slide a seal save, similar to X6550, over the shaft splines to ensure that the seal is not damaged during installation. Place the primary ring and lubricated bellows assembly (without the spring) on the shaft, using a proper pusher - push the assembly into position so that the seal surfaces are in contact. Remove the seal save from the shaft.

The approximate size of a drop should be between the sizes of these two circles.

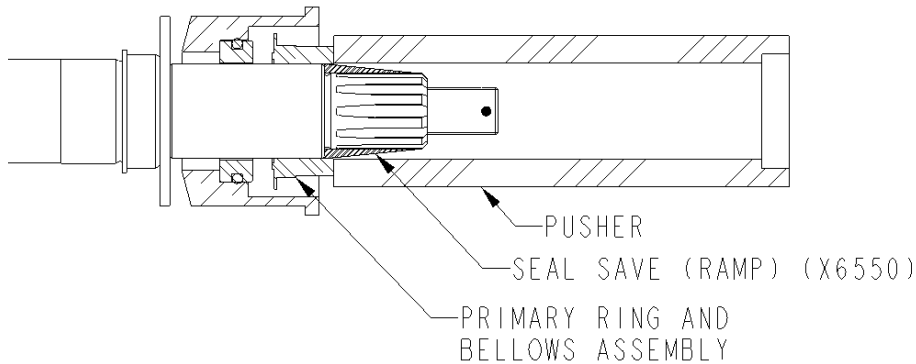
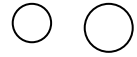

8. Put the spring in place, seated tight against the spring retainer on the primary ring.  
Note: Some springs may be slightly tapered, so one end fits the seal better than the other. The end of the spring that best fits the seal should go towards the seal to ensure even spring pressure all the way around.
9. Slide impeller onto impeller shaft, engage the spring into the groove of the impeller hub and install impeller washer, impeller nut, and stainless steel cotter key.

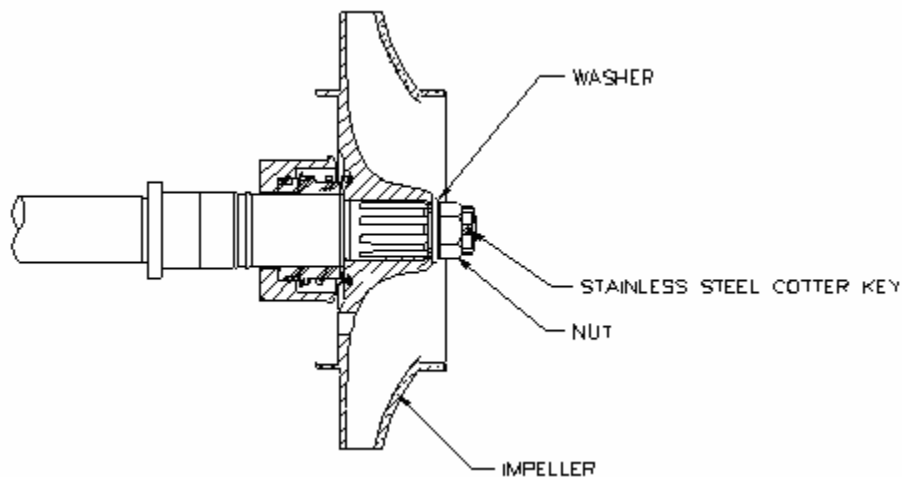

*\*\* Reference pump configuration for individual mechanical seal instructions.*

*\*\* Reference pump assembly drawings and pump assembly tips for further assembly.*

Note: If the seal leaks slightly after assembly, it may be necessary to run the pump for approximately 30 minutes at 50-60 psi to rinse out excess lubricant and other contaminants.

Once a mechanical seal has been installed, it is recommended that it not be reused.

If further information is needed, call **DARLEY** in Chippewa Falls, WI. at 800-634-7812 or 715-726-2650



## W. S. DARLEY & CO.

### SOME CARE AND HANDLING INSTRUCTIONS

1. **DO NOT USE THIS PUMP FOR HOSE TESTING!**
2. Avoid unnecessary force and rough handling of parts during disassembly and reassembly.
3. Clean parts thoroughly and maintain free from abrasive foreign matter.
4. Keep bearings in original containers until ready to install.
5. Work with clean tools in clean surroundings during reassembly.
6. Do not bump or abrade machined surfaces, giving special care to wearing surfaces, shaft shoulders, gear and impeller hub faces, gear teeth, etc.
7. Use an arbor press for forcing press fits whenever possible. If necessary to use a hammer, use one having soft plastic heads.
8. Use suitable machined and fitted sleeves or bars for forcing or pressing ball bearings and other parts having press fits.
9. Do not press a ball bearing onto a shaft by forcing against the outer race. Heavy pressure or impact against bearing balls will damage the bearing and cause premature failure.
10. If necessary to remove a ball bearing from a shaft by forcing against the outer race, the bearing should be discarded and replaced.
11. When forcing or pressing a bearing or other part onto a tight fitting shaft, the part must be started square with the shaft and forced on squarely all the way.
12. Clean and oil bearing seats and other parts having press fits to prevent galling.
13. Keep loose parts marked or otherwise identified to avoid errors in assembly.
14. When filling the gearcase with oil, fill it with SAE80W/90 gear lube oil to the bottom of the oil level plug located on the gear case.
15. Maintain the gearcase oil level every 25 hours, or every 3 months which ever comes first, and change the oil every 50 hours, or every 6 months, which ever comes first.

IF FURTHER INFORMATION IS NEEDED, CALL **W.S. DARLEY & CO.** AT  
CHIPPEWA FALLS, WI. AT 800-634-7812 or 715-726-2650



**DARLEY**

## BASIC ASSEMBLING TECHNIQUES

- Work with clean tools in clean surroundings during assembly.
- Clean parts thoroughly and keep free from nicks and abrasions.
- Keep loose parts marked otherwise identified to avoid error in assembly.
- **Bearings:** Keep bearings in original containers until ready to install.
- **Bearings/Press fits:** Clean and oil bearing seats and other parts having press fits to prevent galling.
- **Bearings:** When pressing a bearing onto a shaft, the bearing must be started perpendicular (square) to the shaft.



- **Bearings:** When pressing bearings onto a shaft all forces applied to the bearing need to be applied to the inner race.
- **Bearings:** When pressing bearings into a pocket all forces applied to the bearing need to be applied to the outer race.
- **Bearings:** When installing a bearing with one shield, the open side goes toward the oil cavity/gear case. Typically the single shield will be next to an oil seal.

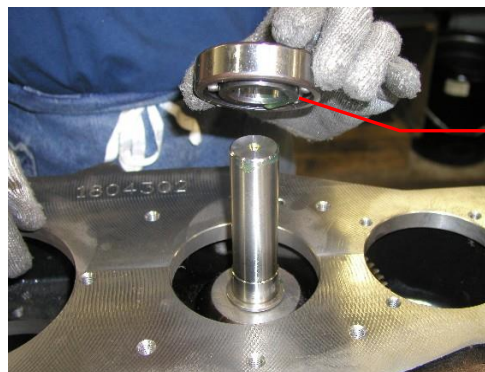

**OPEN SIDE  
OF BEARING**

- **Bearings:** When pressing a bearing onto a shaft, lightly lube the bore of the bearing and the shaft journal for the bearing with oil. Also when installing bearings into bearing pockets, lightly lube the OD of the bearing and the bore of the bearing pocket with oil.



- **Bearings:** If necessary to remove a ball bearing from a shaft by forcing against the outer race, the bearing should be discarded and replaced.
- **Press fits:** Use suitable machined pushers (The end faces of the pusher should be flat, parallel and burr free) for pressing operations.



**SUITABLE  
PUSHERS**



- **Press fits:** When pressing a part into housing (ex. Stuffing box, seal ring, etc.), the part needs to be started perpendicular to the housing.



- **Tail Shaft Oil Seals:** All 3 tail shaft oil seals should be filled with a multi-purpose grease as shown below. Also apply a thin layer of grease to the inner lip of the oil seal.

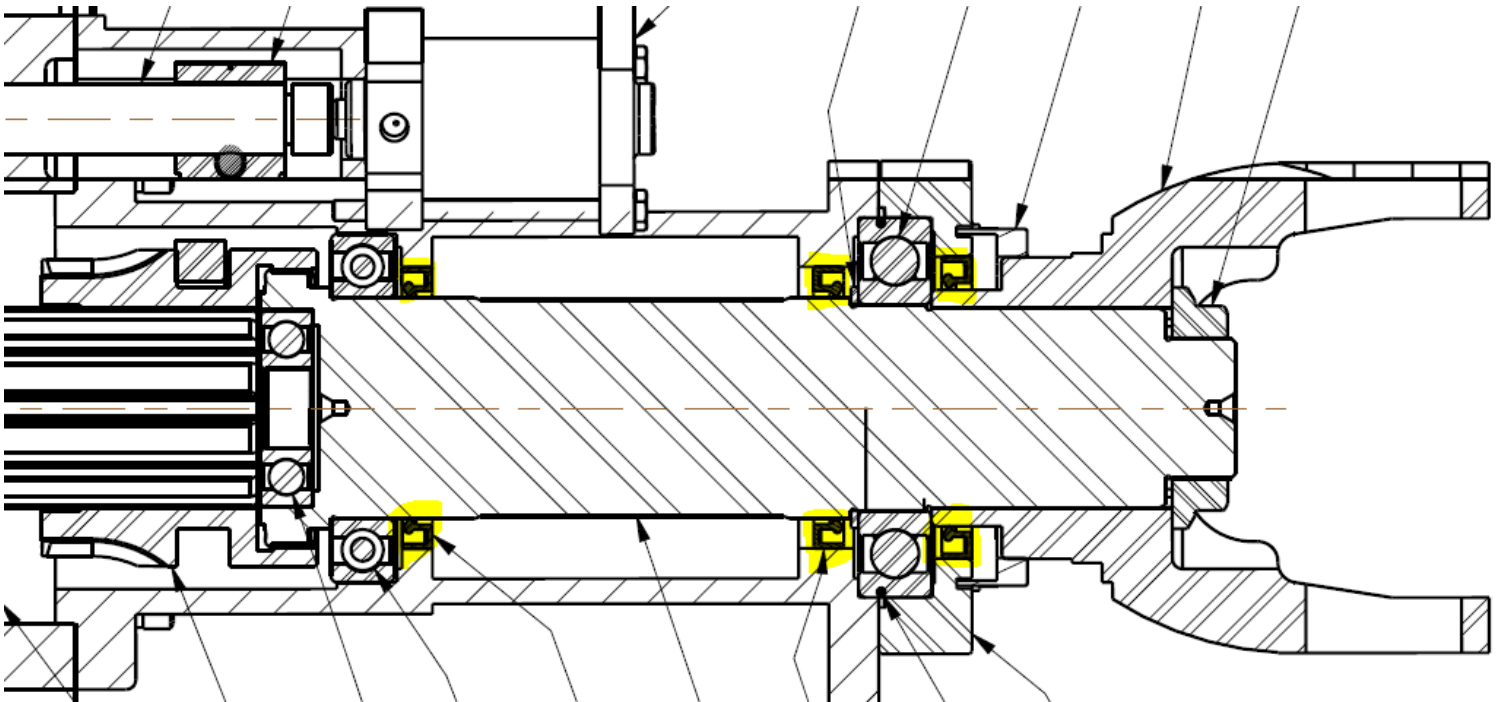

- **Press fits:** Use a press for forcing press fits whenever possible. If necessary to use a hammer, use one having soft plastic heads. Do not use brass or lead hammers, for the face of the hammer may easily chip or flake, contaminating the assembly, which can cause severe damage to bearings and other precision components.
- **Impeller Nuts:** When installing impeller nuts, DO NOT use an impact wrench. Use of impact wrenches has proven to damage the impeller washers, impellers, and impeller shafts. Proper tightening procedure is to bring it snug tight, and then tighten it to the next available cotter pin hole in shaft and notch in the castle nut. Then install stainless steel cotter pin.

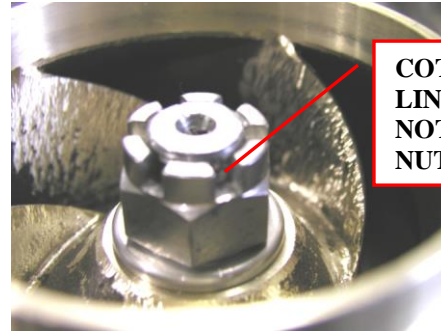

**COTTER PIN HOLE  
LINED UP WITH  
NOTCH IN CASTLE  
NUT**

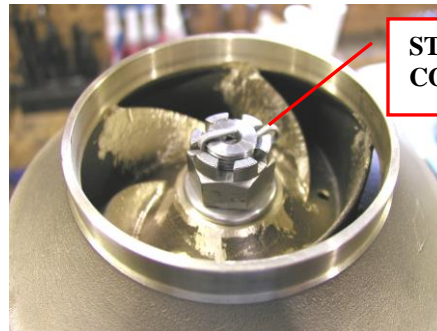
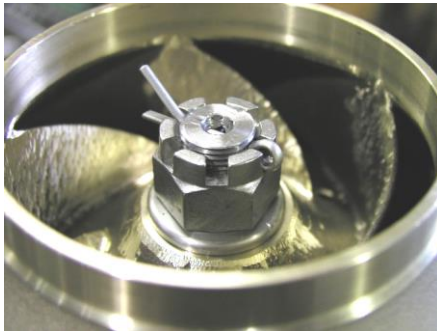

**STAINLESS STEEL  
COTTER PIN**



- **Lock Washer/Lock Nut:** Secure shaft so that it doesn't rotate when tightening lock nut. Line up tab on lock washer with keyway slot in shaft and slide washer onto shaft. Screw lock nut onto shaft until snug, then turn until a tab and slot line up. Using a punch, tap tab from lock washer into slot on lock nut.

**PROPER  
FIXTURE TO  
HOLD SHAFT**

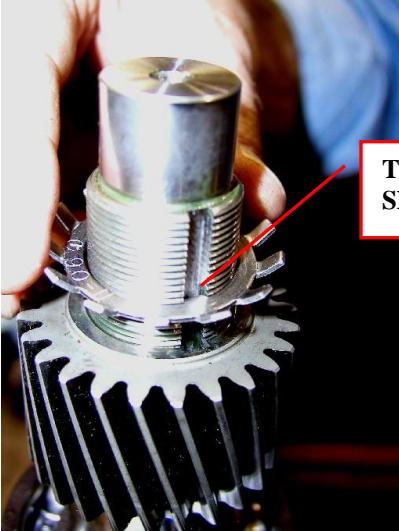
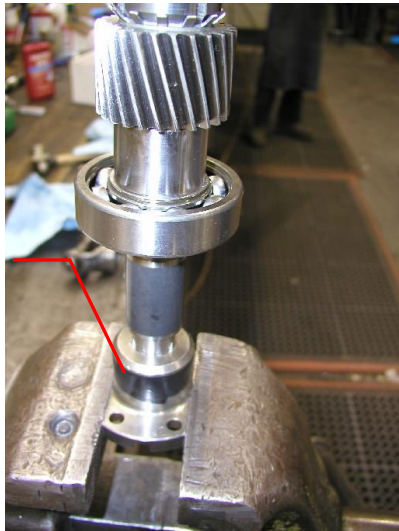

**TAB IN KEYWAY  
SLOT**



**TAB IN  
SLOT ON  
LOCK NUT**

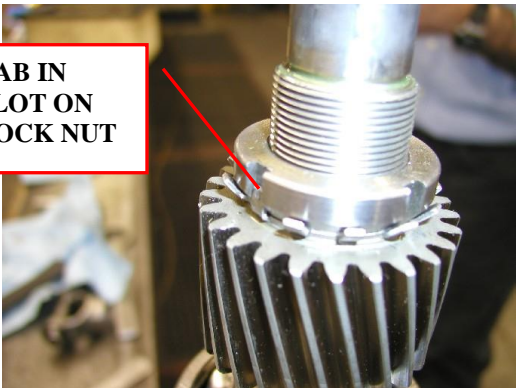

- **Loctite/thread locker:** When applying Loctite/thread lockers, only use one small drop per hole, unless explicitly told differently by engineering, a WI, or assembly/repair instruction or assembly supervisor.
- **Loctite/thread locker:** When applying Loctite/thread lockers to lock fasteners going into captive holes (a hole that is only open on one end), apply the thread locker to the threads of the hole.



- **Loctite/thread locker:** When applying Loctite/thread lockers, to lock fasteners that are going to be installed with a pneumatic/power wrench, apply the thread locker to the female threads.
- **Transmission Threads:** Use only lock washers on captive holes. The only exception is if it is an aluminum gear case, then use Loctite 243, or equivalent, and no lock washers.
- **Transmission Threads:** Use lock washers and Loctite 243, or equivalent, if holes are tapped thru.
- **Inspection Plate Fasteners:** Use Loctite 243, or equivalent, on the fasteners that hold the rectangular inspection plate to the side of the transmissions gear case. When installing these fasteners, install all of the fasteners to finger tight, then torque them to a final torque of 72 in.-lbs. in an alternating crossover pattern.

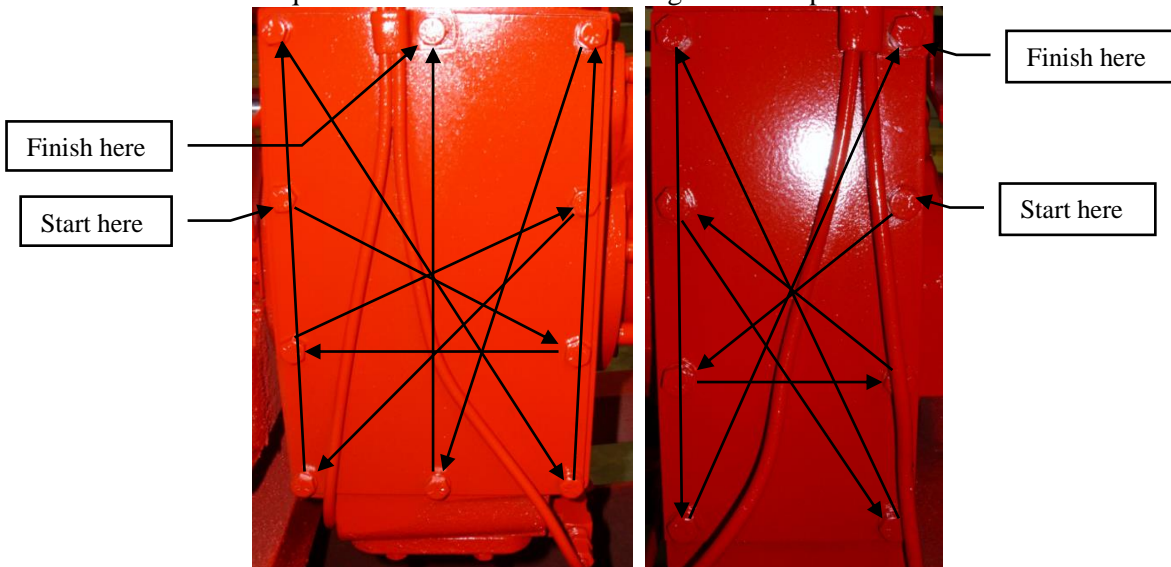

- **Fastener Lock Washers and Aluminum:** Do not use lock washers against aluminum. Use the appropriate thread locker instead.

- **O-rings/Quad rings:** When installing o-rings and quad rings LIGHTLY lube with oil or silicon grease (Dow Corning 111). Be careful not to apply too thick of a film of lubricant when using the silicone grease because over application of the grease can cause the o-ring/quad ring to bridge and leak.



- **Gear Lube:** When filling the gear case with oil, fill with SAE80W/90 gear lube oil to the bottom of the oil level plug on the gear case, or the oil level mark on the dipstick. Maintain the gear case oil level every 25 hours or 3 months, which ever comes first, and change the oil every 50 hours or 6 months.
- **Oil Seal lubrication:** When lubricating oil seals prior to installation, apply a minimal amount of SAE 80/W90 oil on the outside diameter of the seal and the sealing lip on the inside diameter of the seal. Do not use any lubricant other than SAE 80W/90 oil unless a Darley document dated after February 14, 2012 specifically calls it out.

- **Yoke nut installation torque for PUC and PUC-3G pumps:** Torque PUC and PUC-3G yoke nuts to 300-350 ft-lb. After the yoke nut has been torqued down, check to make sure the yoke nut engages the yoke face it bumps up against.

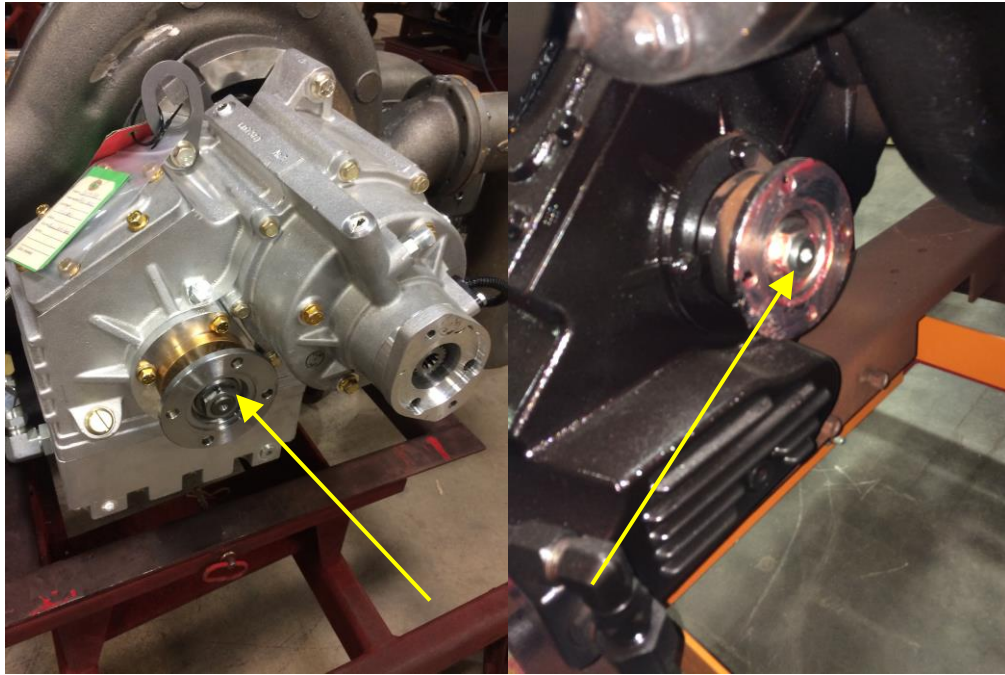

**PUC and PUC-3G yoke nuts are tightened to 300-350 lb-ft.**

- **Yoke nut torque for 1.75-12 thread, 1.25-12 thread and 7/8-14 thread yoke nuts:** Unless otherwise specified, torque 1.75-12 interference threaded yoke nuts to 150-200 ft-lb. Unless otherwise specified, torque all 1.25-12 thread yoke nuts to 150-200 ft-lb. Unless otherwise specified, torque all 7/8-14 interference threaded yoke nuts to 125 ft-lb. After the yoke nut has been torqued down, check to make sure the yoke nut engages the yoke face it bumps up against.

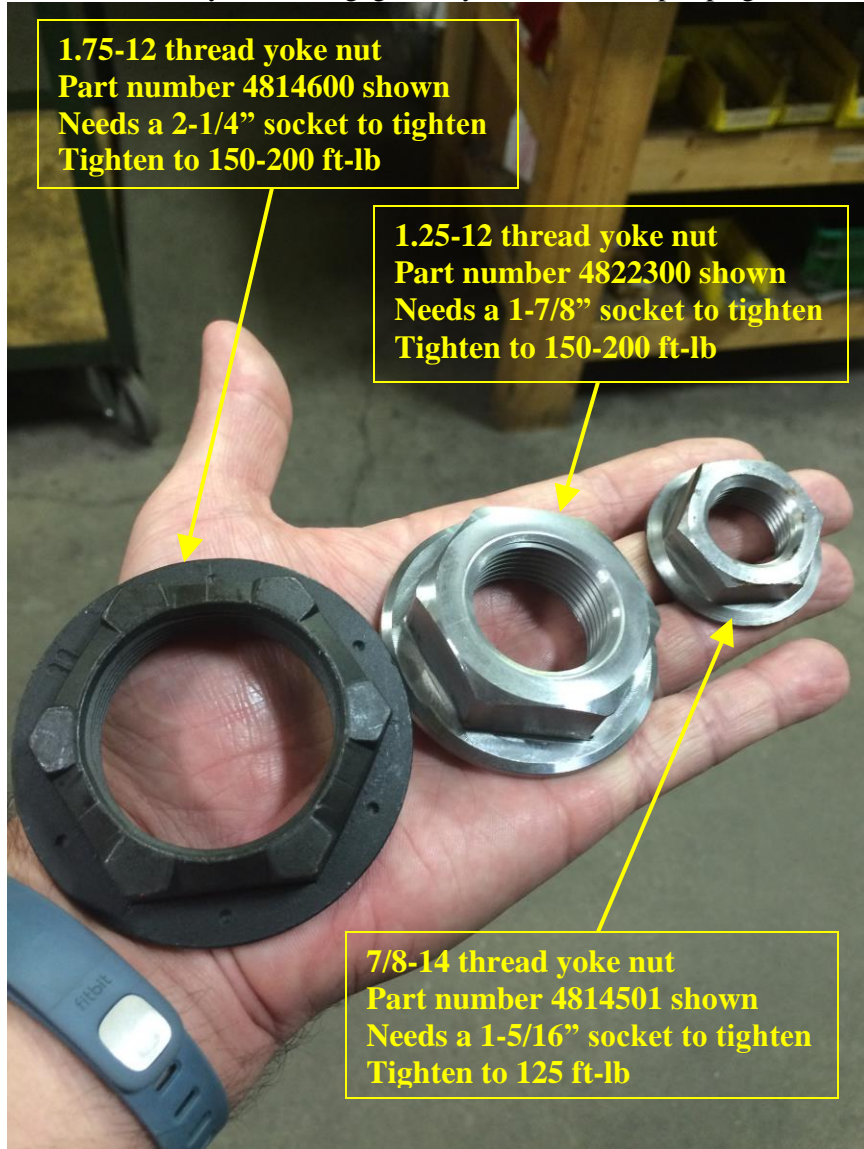

**1.75-12 thread yoke nuts are typically used on Midship pump.**  
**1.25-12 thread yoke nuts are typically used on ZSD & ZSP pumps.**  
**7/8-14 thread yoke nuts are used on PTO pumps.**



**All 1.75-12 interference threaded yoke nuts are torqued to 150-200 ft-lb.**

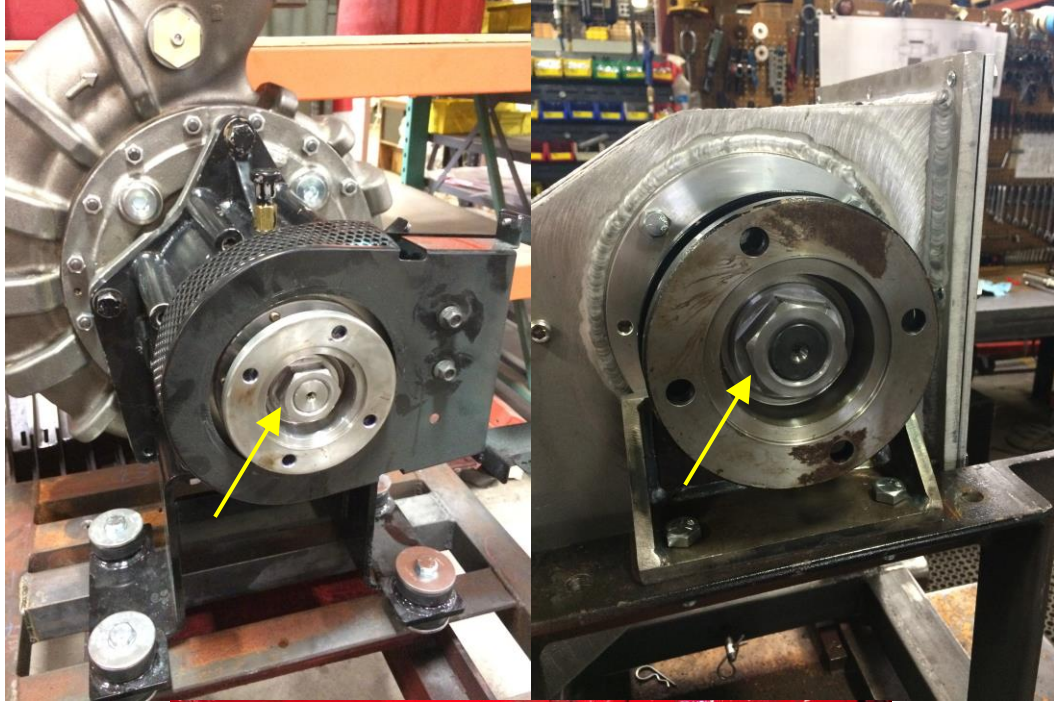

**All 1.25-12 threaded yoke nuts are torqued to 150-200 ft-lb.**

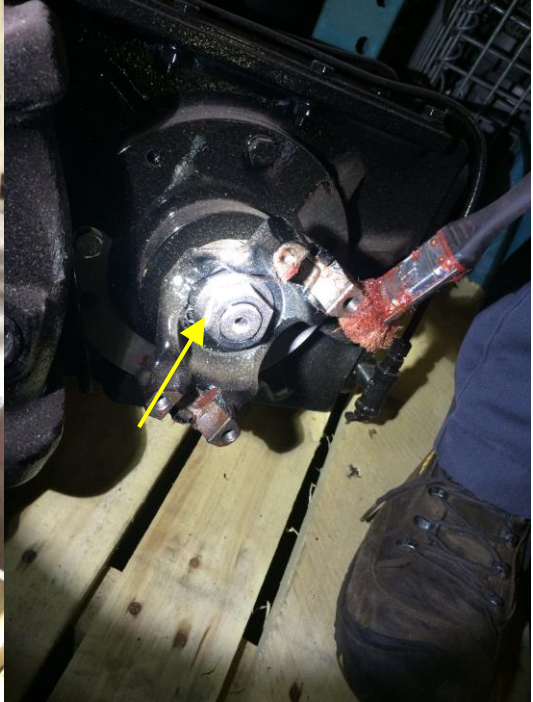
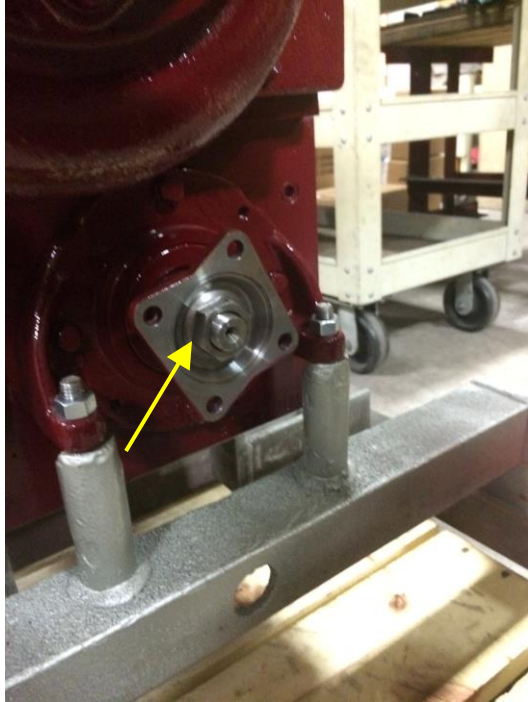
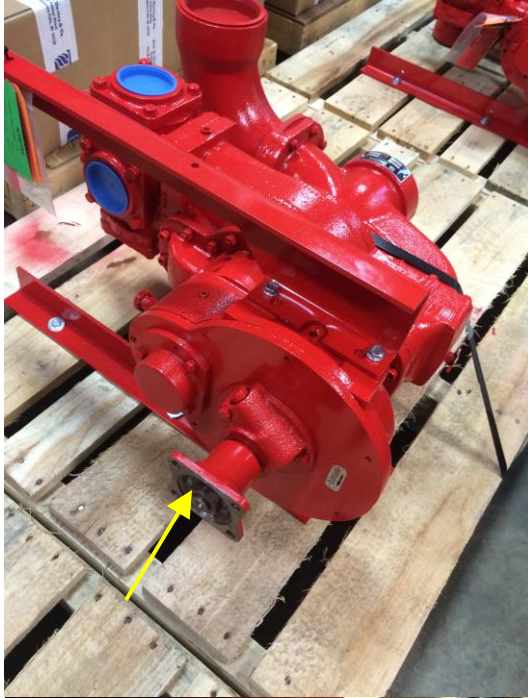

**All 7/8-14 interference thread yoke nuts are tightened to 125 ft-lb.**





**After torquing the yoke nut down, check to make sure there is not a gap between the yoke nut and the yoke.**

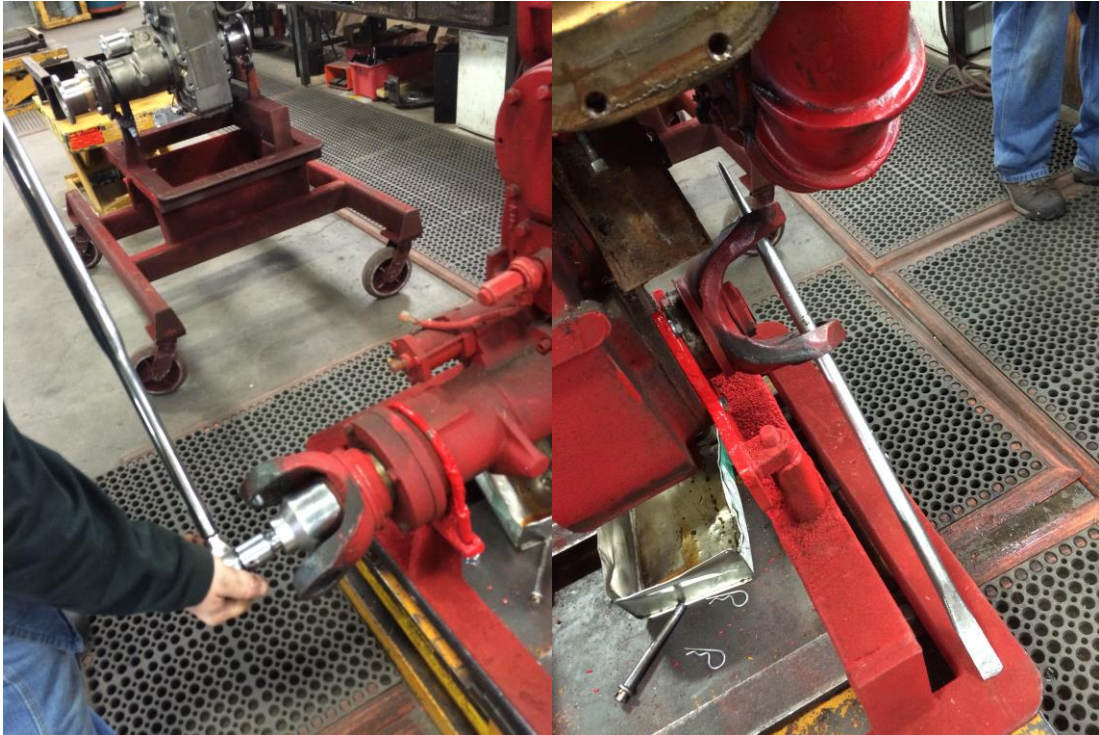

**To help with the yoke nut torquing on midship pumps, shift the transmission into road mode. Put a bar thru the yoke that is not being torqued down to stop the driveline from rotating. Then the driveline will not rotate as the yoke nut is being torqued.**

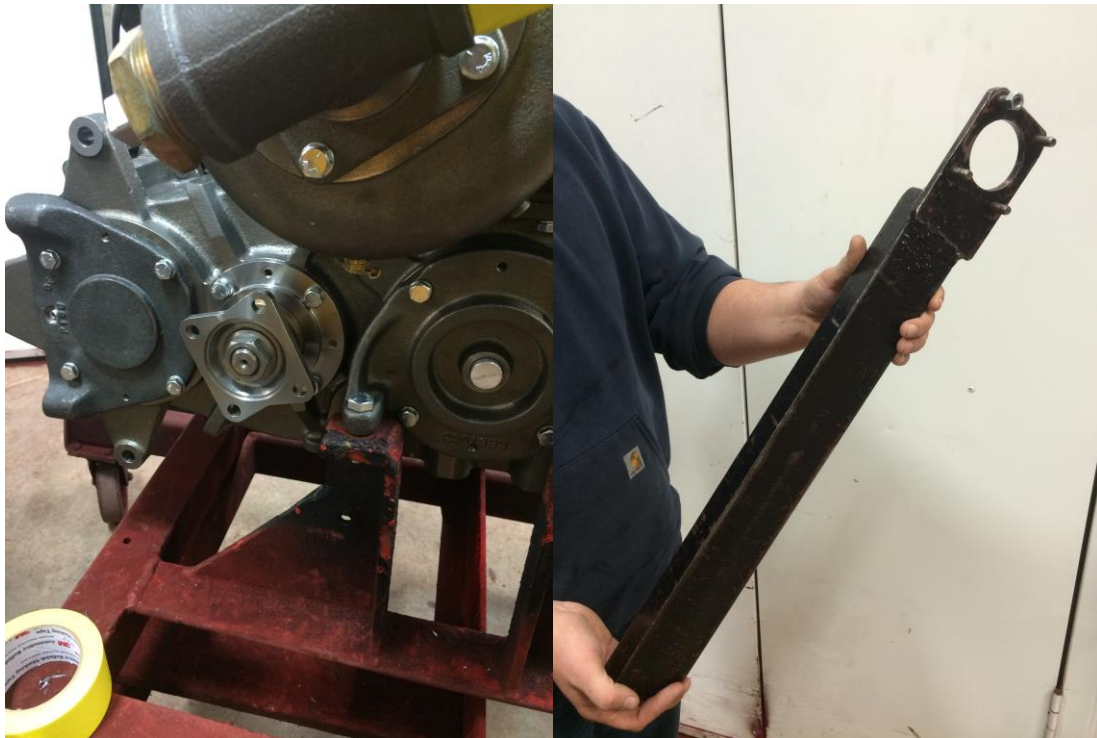

**To help with tightening yoke nuts on PTO pumps use the tool shown in the above picture.**

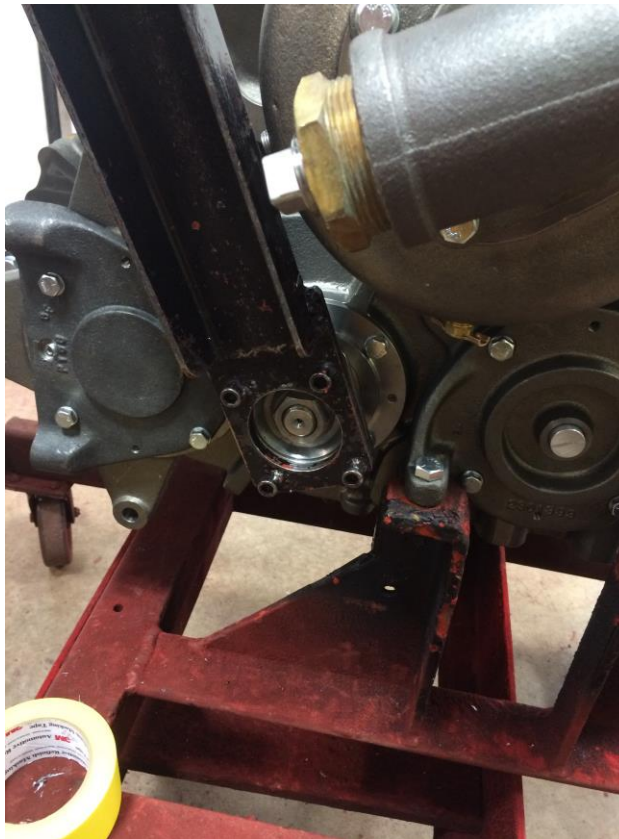

**Place the tool over the companion flange as shown above. Make sure to finger tighten a nut on one of the tool's fasteners to secure the tool to the yoke.**



**Now let the tool bump up against a rigid surface and use the torque wrench to tighten the yoke nut as shown above.**

**Recommended fastener tightening torque unless otherwise specified:** The following tables will give recommended tightening torques depending upon the fasteners material and if a Loctite type product was used. Use these recommended tightening torques if you are not confident torqueing a fastener. For fasteners that had a Loctite type product applied to their threads, use the K = .20 (Clean non-plated bolt) recommended tightening torque even if either the nut or bolt was zinc electroplated.

Best practice is to; use an SAE Grade 8 bolt with an SAE Grade 8 nut, use an SAE Grade 5 bolt with and SAE Grade 5 nut, use an SAE Grade 2 bolt with an SAE Grade 2 nut and use the same bolt material as what the nut is made from.

Fastener Size	Recommended tightening torque	Clamp load
#6 – 32 Grade 8	18 to 27 in-lb	654 to 981 lb
#6 – 40 Grade 8	20 to 30 in-lb	730 to 1,095 lb
#8 – 32 Grade 8	33 to 50 in-lb	1,009 to 1,513 lb
#8 – 36 Grade 8	35 to 52 in-lb	1,060 to 1,591 lb
#10 – 24 Grade 8	48 to 72 in-lb	1,262 to 1,893 lb
#10 – 32 Grade 8	55 to 82 in-lb	1,440 to 2,159 lb
¼ - 20 Grade 8	115 to 172 in-lb	2,291 to 3,437 lb
¼ - 28 Grade 8	131 to 196 in-lb	2,619 to 3,928 lb
5/16 – 18 Grade 8	20 to 29 ft-lb	3,775 to 5,662 lb
5/16 – 24 Grade 8	22 to 33 ft-lb	4,181 to 6,271 lb
3/8 – 16 Grade 8	35 to 52 ft-lb	5,579 to 8,369 lb
3/8 – 24 Grade 8	40 to 59 ft-lb	6,324 to 9,485 lb
7/16 – 14 Grade 8	56 to 84 ft-lb	7,654 to 11,481 lb
7/16 – 20 Grade 8	62 to 93 ft-lb	8,548 to 12,821 lb
½ - 13 Grade 8	85 to 128 ft-lb	10,217 to 15,325 lb
½ - 20 Grade 8	96 to 144 ft-lb	11,517 to 17,275 lb
5/8 – 11 Grade 8	170 to 254 ft-lb	16,272 to 24,408 lb
5/8 – 18 Grade 8	192 to 288 ft-lb	18,429 to 27,643 lb
¾ - 10 Grade 8	301 to 452 ft-lb	24,081 to 36,122 lb
¾ - 16 Grade 8	336 to 503 ft-lb	26,853 to 40,280 lb
7/8 – 9 Grade 8	485 to 727 ft-lb	33,245 to 49,867 lb
7/8 – 14 Grade 8	535 to 802 ft-lb	36,682 to 55,023 lb
1 – 8 Grade 8	727 to 1,090 ft-lb	43,614 to 65,421 lb
1 – 12 Grade 8	796 to 1,193 ft-lb	47,739 to 71,608 lb

The above table is for SAE Grade 8 fasteners, K = .20 (Clean non-plated fasteners or Loctited zinc electroplated fasteners)

Fastener Size	Recommended tightening torque	Clamp load
#6 – 32 Grade 8	20 to 30 in-lb	654 to 981 lb
#6 – 40 Grade 8	22 to 33 in-lb	730 to 1,095 lb
#8 – 32 Grade 8	36 to 55 in-lb	1,009 to 1,513 lb
#8 – 36 Grade 8	38 to 57 in-lb	1,060 to 1,591 lb
#10 – 24 Grade 8	53 to 79 in-lb	1,262 to 1,893 lb
#10 – 32 Grade 8	60 to 90 in-lb	1,440 to 2,159 lb
¼ - 20 Grade 8	126 to 189 in-lb	2,291 to 3,437 lb
¼ - 28 Grade 8	144 to 216 in-lb	2,619 to 3,928 lb
5/16 – 18 Grade 8	22 to 32 ft-lb	3,775 to 5,662 lb
5/16 – 24 Grade 8	24 to 36 ft-lb	4,181 to 6,271 lb
3/8 – 16 Grade 8	38 to 58 ft-lb	5,579 to 8,369 lb
3/8 – 24 Grade 8	43 to 65 ft-lb	6,324 to 9,485 lb
7/16 – 14 Grade 8	61 to 92 ft-lb	7,654 to 11,481 lb
7/16 – 20 Grade 8	69 to 103 ft-lb	8,548 to 12,821 lb
½ - 13 Grade 8	94 to 140 ft-lb	10,217 to 15,325 lb
½ - 20 Grade 8	106 to 158 ft-lb	11,517 to 17,275 lb
5/8 – 11 Grade 8	186 to 280 ft-lb	16,272 to 24,408 lb
5/8 – 18 Grade 8	211 to 317 ft-lb	18,429 to 27,643 lb
¾ - 10 Grade 8	331 to 497 ft-lb	24,081 to 36,122 lb
¾ - 16 Grade 8	369 to 554 ft-lb	26,853 to 40,280 lb
7/8 – 9 Grade 8	533 to 800 ft-lb	33,245 to 49,867 lb
7/8 – 14 Grade 8	588 to 883 ft-lb	36,682 to 55,023 lb
1 – 8 Grade 8	800 to 1,199 ft-lb	43,614 to 65,421 lb
1 – 12 Grade 8	875 to 1,313 ft-lb	47,739 to 71,608 lb

The above table is for SAE Grade 8 fasteners, K = .22 (Zinc electroplated bolt or nut)

Fastener Size	Recommended tightening torque	Clamp load
#6 – 32 Grade 5	16 to 24 in-lb	589 to 883 lb
#6 – 40 Grade 5	18 to 27 in-lb	657 to 986 lb
#8 – 32 Grade 5	30 to 45 in-lb	908 to 1,362 lb
#8 – 36 Grade 5	31 to 47 in-lb	954 to 1,432 lb
#10 – 24 Grade 5	43 to 65 in-lb	1,136 to 1,704 lb
#10 – 32 Grade 5	49 to 74 in-lb	1,296 to 1,943 lb
¼ - 20 Grade 5	81 to 122 in-lb	1,623 to 2,434 lb
¼ - 28 Grade 5	93 to 139 in-lb	1,855 to 2,783 lb
5/16 – 18 Grade 5	14 to 21 ft-lb	2,674 to 4,011 lb
5/16 – 24 Grade 5	15 to 23 ft-lb	2,961 to 4,442 lb
3/8 – 16 Grade 5	25 to 37 ft-lb	3,952 to 5,928 lb
3/8 – 24 Grade 5	28 to 42 ft-lb	4,479 to 6,719 lb
7/16 – 14 Grade 5	40 to 59 ft-lb	5,422 to 8,133 lb
7/16 – 20 Grade 5	44 to 66 ft-lb	6,055 to 9,082 lb
½ - 13 Grade 5	60 to 90 ft-lb	7,237 to 10,855 lb
½ - 20 Grade 5	68 to 102 ft-lb	8,158 to 12,236 lb
5/8 – 11 Grade 5	120 to 180 ft-lb	11,526 to 17,289 lb
5/8 – 18 Grade 5	136 to 204 ft-lb	13,054 to 19,581 lb
¾ - 10 Grade 5	213 to 320 ft-lb	17,057 to 25,586 lb
¾ - 16 Grade 5	238 to 357 ft-lb	19,021 to 28,532 lb
7/8 – 9 Grade 5	343 to 515 ft-lb	23,548 to 35,323 lb
7/8 – 14 Grade 5	379 to 568 ft-lb	25,983 to 38,975 lb
1 – 8 Grade 5	515 to 772 ft-lb	30,893 to 46,340 lb
1 – 12 Grade 5	564 to 845 ft-lb	33,815 to 50,723 lb

The above table is for SAE Grade 5 fasteners, K = .20 (Clean non-plated fasteners or Loctited zinc electroplated fasteners)

Fastener Size	Recommended tightening torque	Clamp load
#6 – 32 Grade 5	18 to 27 in-lb	589 to 883 lb
#6 – 40 Grade 5	20 to 30 in-lb	657 to 986 lb
#8 – 32 Grade 5	33 to 49 in-lb	908 to 1,362 lb
#8 – 36 Grade 5	34 to 52 in-lb	954 to 1,432 lb
#10 – 24 Grade 5	47 to 71 in-lb	1,136 to 1,704 lb
#10 – 32 Grade 5	54 to 81 in-lb	1,296 to 1,943 lb
¼ - 20 Grade 5	89 to 134 in-lb	1,623 to 2,434 lb
¼ - 28 Grade 5	102 to 153 in-lb	1,855 to 2,783 lb
5/16 – 18 Grade 5	15 to 23 ft-lb	2,674 to 4,011 lb
5/16 – 24 Grade 5	17 to 25 ft-lb	2,961 to 4,442 lb
3/8 – 16 Grade 5	27 to 41 ft-lb	3,952 to 5,928 lb
3/8 – 24 Grade 5	31 to 46 ft-lb	4,479 to 6,719 lb
7/16 – 14 Grade 5	43 to 65 ft-lb	5,422 to 8,133 lb
7/16 – 20 Grade 5	49 to 73 ft-lb	6,055 to 9,082 lb
½ - 13 Grade 5	66 to 100 ft-lb	7,237 to 10,855 lb
½ - 20 Grade 5	75 to 112 ft-lb	8,158 to 12,236 lb
5/8 – 11 Grade 5	132 to 198 ft-lb	11,526 to 17,289 lb
5/8 – 18 Grade 5	150 to 224 ft-lb	13,054 to 19,581 lb
¾ - 10 Grade 5	235 to 352 ft-lb	17,057 to 25,586 lb
¾ - 16 Grade 5	262 to 392 ft-lb	19,021 to 28,532 lb
7/8 – 9 Grade 5	378 to 567 ft-lb	23,548 to 35,323 lb
7/8 – 14 Grade 5	417 to 625 ft-lb	25,983 to 38,975 lb
1 – 8 Grade 5	566 to 850 ft-lb	30,893 to 46,340 lb
1 – 12 Grade 5	620 to 930 ft-lb	33,815 to 50,723 lb

The above table is for SAE Grade 5 fasteners, K = .22 (Zinc electroplated bolt or nut)

Fastener Size	Recommended tightening torque	Clamp load
#6 – 32 Grade 2	8 to 12 in-lb	300 to 450 lb
#6 – 40 Grade 2	9 to 14 in-lb	335 to 502 lb
#8 – 32 Grade 2	15 to 23 in-lb	462 to 693 lb
#8 – 36 Grade 2	16 to 24 in-lb	486 to 729 lb
#10 – 24 Grade 2	22 to 33 in-lb	579 to 868 lb
#10 – 32 Grade 2	25 to 38 in-lb	660 to 990 lb
¼ - 20 Grade 2	53 to 79 in-lb	1,050 to 1,575 lb
¼ - 28 Grade 2	60 to 90 in-lb	1,200 to 1,801 lb
5/16 – 18 Grade 2	108 to 162 in-lb	1,730 to 2,595 lb
5/16 – 24 Grade 2	120 to 180 in-lb	1,916 to 2,874 lb
3/8 – 16 Grade 2	16 to 24 ft-lb	2,557 to 3,836 lb
3/8 – 24 Grade 2	18 to 27 ft-lb	2,898 to 4,347 lb
7/16 – 14 Grade 2	26 to 38 ft-lb	3,508 to 5,262 lb
7/16 – 20 Grade 2	29 to 43 ft-lb	3,918 to 5,876 lb
½ - 13 Grade 2	39 to 59 ft-lb	4,683 to 7,024 lb
½ - 20 Grade 2	44 to 66 ft-lb	5,278 to 7,918 lb
5/8 – 11 Grade 2	78 to 117 ft-lb	7,458 to 11,187 lb
5/8 – 18 Grade 2	88 to 132 ft-lb	8,447 to 12,670 lb
¾ - 10 Grade 2	138 to 207 ft-lb	11,037 to 16,556 lb
¾ - 16 Grade 2	154 to 231 ft-lb	12,308 to 18,462 lb
7/8 – 9 Grade 2	133 to 200 ft-lb	9,142 to 13,714 lb
7/8 – 14 Grade 2	147 to 221 ft-lb	10,088 to 15,131 lb
1 – 8 Grade 2	200 to 300 ft-lb	11,994 to 17,991 lb
1 – 12 Grade 2	219 to 328 ft-lb	13,128 to 19,692 lb

The above table is for SAE Grade 2 fasteners, K = .20 (Clean non-plated fasteners or Loctited zinc electroplated fasteners)



Fastener Size	Recommended tightening torque	Clamp load
#6 – 32 Grade 2	9 to 14 in-lb	300 to 450 lb
#6 – 40 Grade 2	10 to 15 in-lb	335 to 502 lb
#8 – 32 Grade 2	17 to 25 in-lb	462 to 693 lb
#8 – 36 Grade 2	18 to 26 in-lb	486 to 729 lb
#10 – 24 Grade 2	24 to 36 in-lb	579 to 868 lb
#10 – 32 Grade 2	28 to 41 in-lb	660 to 990 lb
¼ - 20 Grade 2	58 to 87 in-lb	1,050 to 1,575 lb
¼ - 28 Grade 2	66 to 99 in-lb	1,200 to 1,801 lb
5/16 – 18 Grade 2	119 to 178 in-lb	1,730 to 2,595 lb
5/16 – 24 Grade 2	132 to 198 in-lb	1,916 to 2,874 lb
3/8 – 16 Grade 2	18 to 26 ft-lb	2,557 to 3,836 lb
3/8 – 24 Grade 2	20 to 30 ft-lb	2,898 to 4,347 lb
7/16 – 14 Grade 2	28 to 42 ft-lb	3,508 to 5,262 lb
7/16 – 20 Grade 2	31 to 47 ft-lb	3,918 to 5,876 lb
½ - 13 Grade 2	43 to 64 ft-lb	4,683 to 7,024 lb
½ - 20 Grade 2	48 to 73 ft-lb	5,278 to 7,918 lb
5/8 – 11 Grade 2	85 to 128 ft-lb	7,458 to 11,187 lb
5/8 – 18 Grade 2	97 to 145 ft-lb	8,447 to 12,670 lb
¾ - 10 Grade 2	152 to 228 ft-lb	11,037 to 16,556 lb
¾ - 16 Grade 2	169 to 254 ft-lb	12,308 to 18,462 lb
7/8 – 9 Grade 2	147 to 220 ft-lb	9,142 to 13,714 lb
7/8 – 14 Grade 2	162 to 243 ft-lb	10,088 to 15,131 lb
1 – 8 Grade 2	220 to 330 ft-lb	11,994 to 17,991 lb
1 – 12 Grade 2	241 to 361 ft-lb	13,128 to 19,692 lb

The above table is for SAE Grade 2 fasteners, K = .22 (Zinc electroplated nut or bolt)

Fastener Size	Recommended tightening torque	Clamp load
#6 – 32	3 to 5 in-lb	125 to 188 lb
#6 – 40	4 to 6 in-lb	140 to 210 lb
#8 – 32	6 to 10 in-lb	193 to 290 lb
#8 – 36	7 to 10 in-lb	203 to 305 lb
#10 – 24	9 to 14 in-lb	242 to 363 lb
#10 – 32	10 to 16 in-lb	276 to 414 lb
¼ - 20	22 to 33 in-lb	439 to 659 lb
¼ - 28	25 to 38 in-lb	502 to 753 lb
5/16 – 18	45 to 68 in-lb	724 to 1,085 lb
5/16 – 24	50 to 75 in-lb	801 to 1,202 lb
3/8 – 16	80 to 120 in-lb	1,069 to 1,604 lb
3/8 – 24	91 to 136 in-lb	1,212 to 1,818 lb
7/16 – 14	128 to 193 in-lb	1,467 to 2,201 lb
7/16 – 20	143 to 215 in-lb	1,638 to 2,457 lb
½ - 13	16 to 24 ft-lb	1,958 to 2,937 lb
½ - 20	18 to 28 ft-lb	2,207 to 3,311 lb
5/8 – 11	32 to 49 ft-lb	3,119 to 4,678 lb
5/8 – 18	37 to 55 ft-lb	3,532 to 5,298 lb
¾ - 10	58 to 87 ft-lb	4,616 to 6,923 lb
¾ - 16	64 to 97 ft-lb	5,147 to 7,720 lb
7/8 – 9	93 to 139 ft-lb	6,372 to 9,558 lb
7/8 – 14	103 to 154 ft-lb	7,031 to 10,546 lb
1 – 8	139 to 209 ft-lb	8,359 to 12,539 lb
1 – 12	152 to 229 ft-lb	9,150 to 13,725 lb

The above table is for Stainless Steel, Bronze or Aluminum fasteners. By fasteners we are implying nuts or bolts – not stationary components in the clamped joint. K = .20 (Clean non-plated fasteners with or without a Loctite type product)

Socket set screw size	Minimum tightening torque for alloy steel socket set screws	Minimum tightening torque for stainless socket set screws
#6	10 in-lb	7 in-lb
#8	19 in-lb	16 in-lb
#10	34 in-lb	26 in-lb
¼	78 in-lb	70 in-lb
5/16	156 in-lb	130 in-lb
3/8	23 ft-lb	230 in-lb
7/16	36 ft-lb	28 ft-lb
1/2	51 ft-lb	42 ft-lb
5/8	110 ft-lb	82 ft-lb
3/4	179 ft-lb	142 ft-lb
7/8	428 ft-lb	333 ft-lb
1	584 ft-lb	467 ft-lb

The above table is the recommended minimum tightening torque for alloy steel and stainless socket set screws. Please note the recommended tightening torque is the same for both fine threaded and coarse threaded set screws

For reference, Recommended tightening torque is found by the following equation;

$$T = KDP$$

T = Tightening torque in units of inch-pound.

K = Nut factor and it is unit less.

D = Nominal bolt diameter in units of inch.

P = Clamp load in units of pounds.

Nut factor = K = .20 or .22 in these tables. K = .20 for clean non-plated bolts. K = .25 for zinc electroplated bolts. See IFI handbook 6<sup>th</sup> edition on page M-64 for more details.

Our recommended tightening torques is intended to maintain a clamp load of 60% to 90% of the bolt's proof load. See Mechanical Engineering Design ISBN 0-07-056888-X page 382 for more details.

We assumed a Grade 8 proof load of 120,000 psi for all fasteners sizes.

We assumed a Grade 5 proof load of 85,000 psi for fasteners 1/4" in bolt diameter up to 1" in bolt diameter. We assumed a Grade 5 proof load of 108,000 psi for fasteners #6 up to #10 in bolt diameter. We assumed a Grade 2 proof load of 33,000 psi for fasteners larger than 3/4" in bolt diameter up to 1-1/2" in bolt diameter. We assumed a Grade 2 proof load of 55,000 psi for fasteners #6 in bolt diameter up to 5/8" in bolt diameter.

We assumed a proof load of 23,000 psi for all Stainless Steel, Bronze and Aluminum material fasteners. Sand cast 356.0-T6 aluminum has a yield strength of 24,000 psi listed in the ASM Specialty Handbook Aluminum and Aluminum Alloys on page 720.

Fastener Size	Nominal bolt diameter (in)	Tensile stress area (square inch)	Stainless, Brass, Bronze or Aluminum proof load (lb)	SAE Grade 2 proof load (lb)	SAE Grade 5 proof load (lb)	SAE Grade 8 proof load (lb)
#6 – 32	.1380	.00909	209	500	981	1,090
#6 – 40	.1380	.01015	233	558	1,095	1,217
#8 – 32	.1640	.0140	322	770	1,513	1,681
#8 – 36	.1640	.01474	339	810	1,591	1,767
#10 – 24	.1900	.0175	403	964	1,893	2,104
#10 – 32	.1900	.0200	460	1,100	2,159	2,399
1/4 - 20	.250	.0318	732	1,750	2,705	3,819
1/4 - 28	.250	.0364	837	2,001	3,092	4,365
5/16 – 18	.3125	.0524	1,206	2,884	4,457	6,292
5/16 – 24	.3125	.0580	1,336	3,194	4,936	6,968
3/8 – 16	.375	.0775	1,782	4,262	6,587	9,299
3/8 – 24	.375	.0878	2,020	4,831	7,465	10,539
7/16 – 14	.4375	.1063	2,445	5,847	9,036	12,757
7/16 – 20	.4375	.1187	2,730	6,529	10,091	14,246
1/2 - 13	.500	.1419	3,264	7,804	12,061	17,028
1/2 - 20	.500	.1599	3,679	8,797	13,596	19,194
5/8 – 11	.625	.226	5,198	12,430	19,210	27,120
5/8 – 18	.625	.256	5,887	14,078	21,759	30,715
3/4 - 10	.750	.334	7,693	18,395	28,429	40,135
3/4 - 16	.750	.373	8,578	20,513	31,702	44,755
7/8 – 9	.875	.462	10,620	15,237	39,247	55,408
7/8 – 14	.875	.509	11,718	16,813	43,305	61,137
1 – 8	1.000	.606	13,932	19,990	51,488	72,689
1 – 12	1.000	.663	15,250	21,880	56,359	79,565

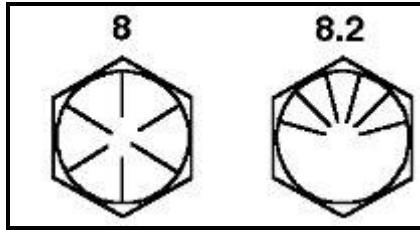

The above image shows how SAE Grade 8 hex head bolts can be identified.

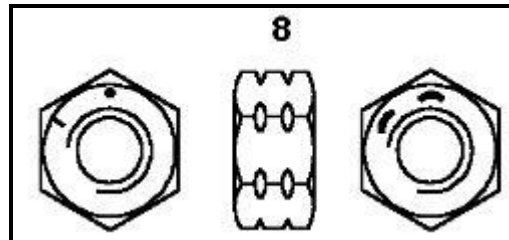

The above image shows how SAE Grade 8 hex nuts can be identified.

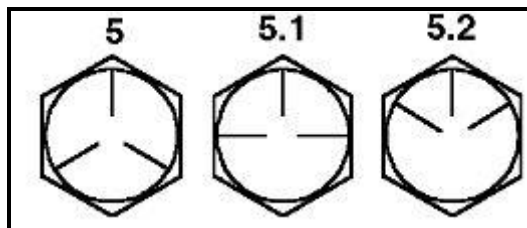

The above image shows how SAE Grade 5 hex head bolts can be identified.

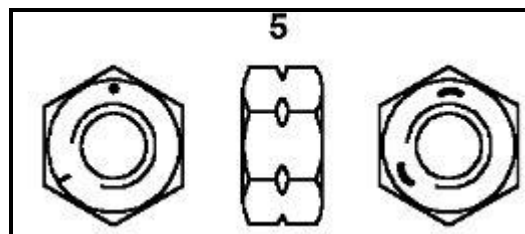

The above image shows how SAE Grade 5 hex nuts can be identified.

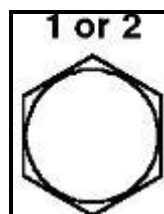

The above image shows how SAE Grade 2 hex head bolts can be identified.

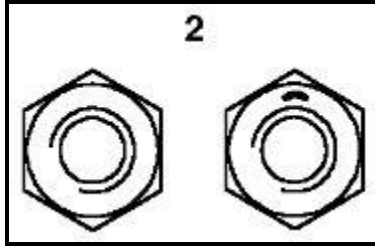

The above image shows how SAE Grade 2 hex nuts can be identified.

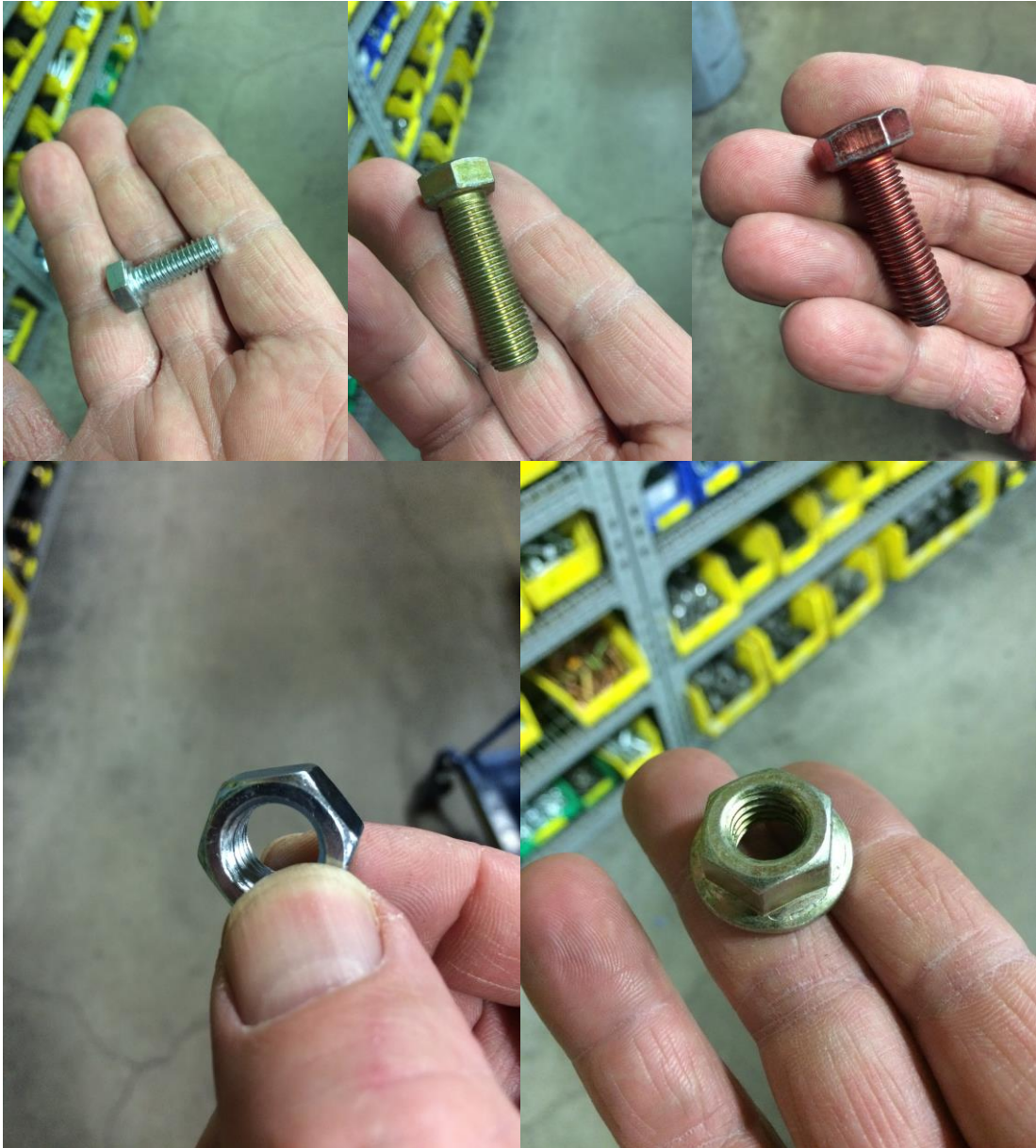

**The above images show different types of zinc electroplated fasteners.**



**The above images show different types of clean non-plated fasteners.**

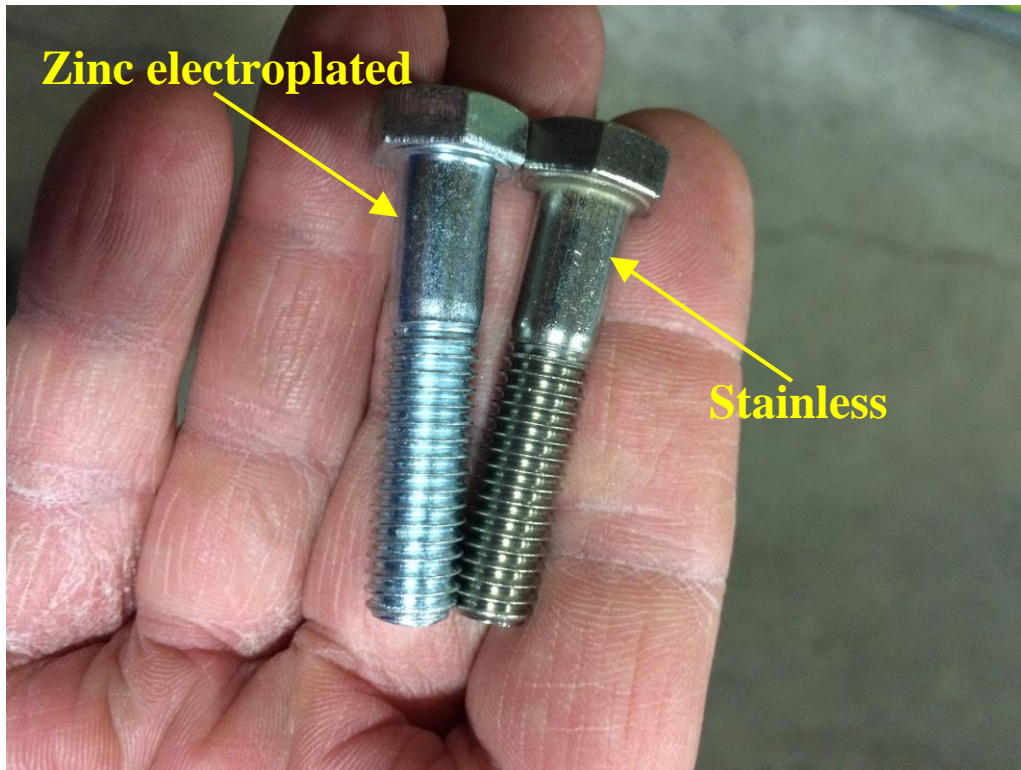

**The bolt on the left is zinc electroplated.  
The bolt on the right is stainless steel.**



**The above image is a brass machine screw and brass hex nut.**





**All alloy steel socket head cap screws have an 180,000 psi tensile strength for 1/2" and smaller bolts and 170,000 psi tensile strength for 5/8" and larger bolts. Use the SAE Grade 8 recommended tightening torque tables for socket head cap screws.**



**All alloy steel socket flat countersunk head cap screws have a 150,000 psi minimum tensile strength. Use the SAE Grade 8 recommended tightening torque tables for alloy steel socket flat countersunk head cap screws.**



All alloy steel socket button head cap screws have a 137,000 psi minimum tensile strength. Use the SAE Grade 5 recommended tightening torque tables for alloy steel socket button head cap screws.



The fasteners on the left are alloy steel socket set screws. The fasteners on the right are stainless socket set screws.

If further information is needed, call **Darley** at  
Chippewa Falls, WI. - 800-634-7812 or 715-726-2650

Prepared by: DLH  
Approved by: Engineering  
Revised by: GDY

30 of 30

Rev.#: 7  
Date: 4/19/05  
1205529

Rev Date: 28 Sep, 2017 ECO EN 11785