

8 7 6 5 4 3 2 1

REVISIONS				
ZONE	REV.	DESCRIPTION	DATE	APPROVED
A1	A	changed PN to AK310 per internal part number, modified dims to be fractions per inspection standards	11/19/2018	smc

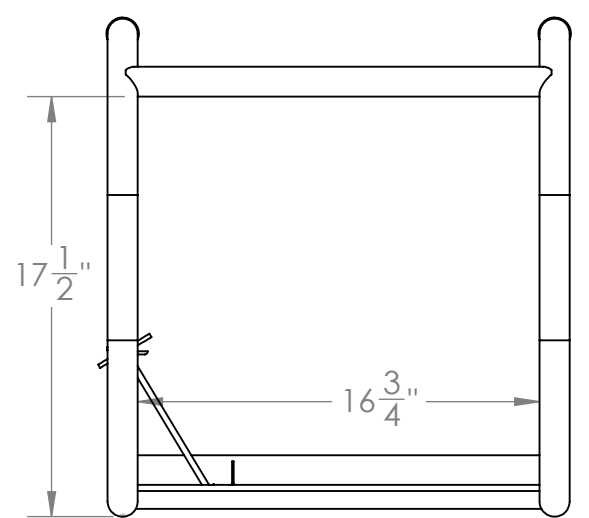
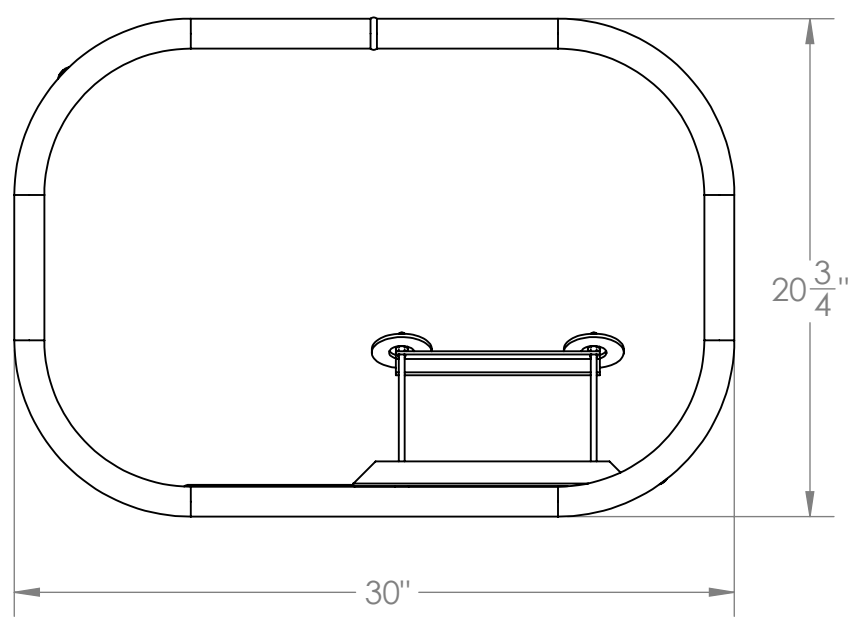
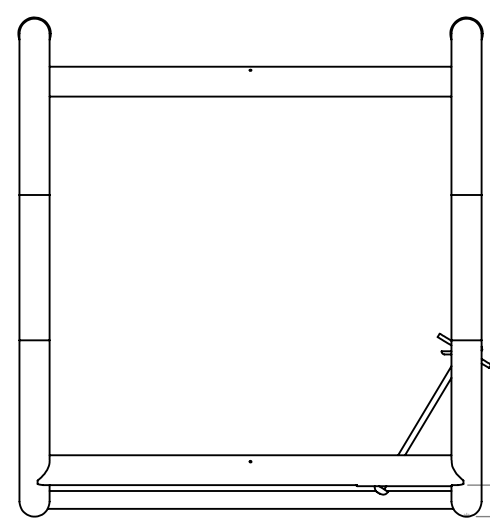
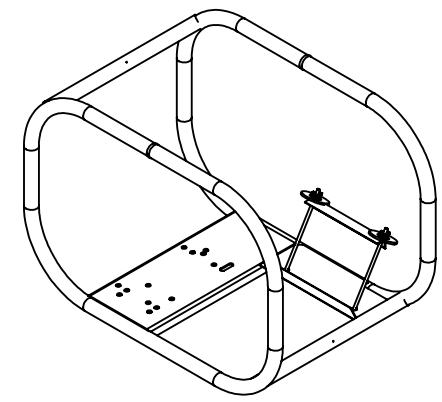
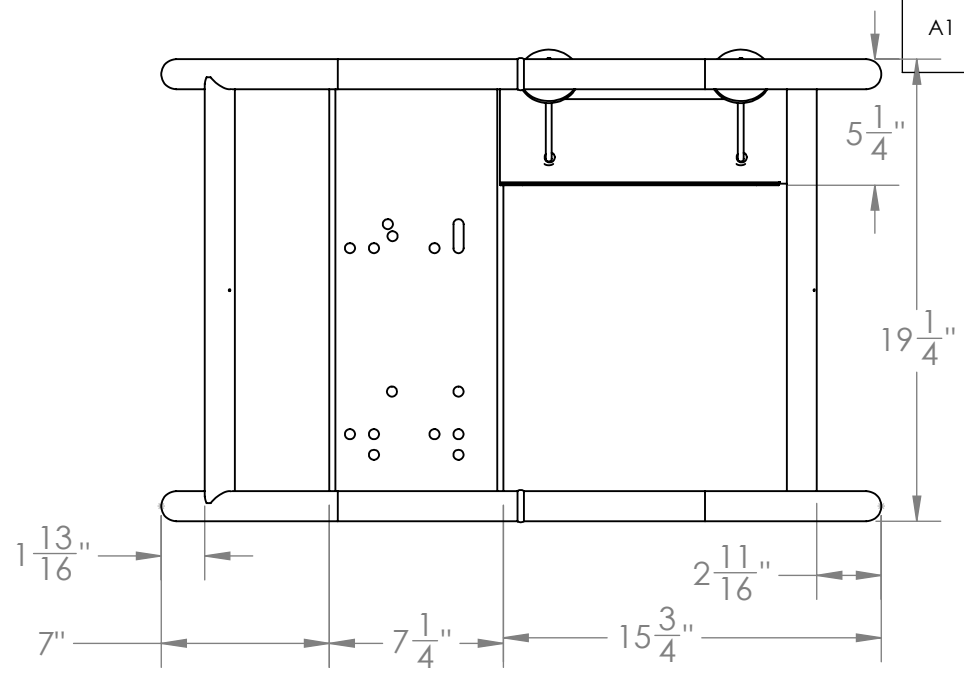

D  
C  
B  
A

D  
C  
B  
A

**PROPRIETARY AND CONFIDENTIAL**  
 THE INFORMATION CONTAINED IN THIS DRAWING IS THE SOLE PROPERTY OF **OHLER PUMPS, DIVISION OF W.S. DARLEY & CO.** ANY REPRODUCTION IN PART OR AS A WHOLE WITHOUT THE WRITTEN PERMISSION OF **OHLER PUMP, DIVISION OF W.S. DARLEY & CO.** IS PROHIBITED.

UNLESS OTHERWISE SPECIFIED:		NAME	DATE
DIMENSIONS ARE IN INCHES		DRAWN	ASM
TOLERANCES:		CHECKED	7-8-08
FRACTIONAL ± 1/32		ENG APPR.	
ANGULAR: MACH ± 30°		MFG APPR.	
BEND ± 2 degrees		Q.A.	
TWO PLACE DECIMAL ± .030		COMMENTS:	
THREE PLACE DECIMAL ± .010			
INTERPRET GEOMETRIC TOLERANCING PER:			
MATERIAL			
FINISH			
NEXT ASSY	USED ON		
APPLICATION	DO NOT SCALE DRAWING		

TITLE:		
<b>Davey Frame</b>		
SIZE	DWG. NO.	REV
<b>B</b>	<b>AK310</b>	<b>0</b>
SCALE: 1:8	WEIGHT:	SHEET 1 OF 1

8 7 6 5 4 3 2 1