



Odin® Kubota Mustang 100/50 Specification¹

The Mustang provides a self-contained, diesel-powered, “slide-in” type compressed air foam system (CAFS) unit. The CAFS unit shall be designed to fit into the back of a standard length and width pick-up truck body.

The CAFS shall be designed to discharge water only, air only, foam solution only or compressed air foam from the same discharge outlet. In addition, the consistency of the compressed air foam (expansion ratio), wet/dry shall be fully adjustable.

Engine

The power to drive the system shall be provided by a *Kubota* model 1505, liquid cooled, indirect injection, naturally aspirated diesel engine. The heavy duty rating for this engine is 33.5 hp @ 3000 rpm. Automotive engines or ratings will not be used. The power unit shall have re-borable crankcase of grey cast iron. Aluminum heads with replaceable valve guides. The pressure-lubricated engine shall have a 12VDC 40-amp alternator, glow plugs. A remote oil drain shall be supplied.

Water Pump

The water pump shall be a *Darley* model 1½” AGE single-stage centrifugal pump with a vertically split aluminum case with replaceable bronze impeller and seal rings on a stainless steel shaft. It is designed to provide up to 150 gpm of plain water flow and pressures up to 155 psi (10.7 b). The pump seal shall be of a mechanical design. Helical cut gears shall be utilized in the pump transmission.

Air Compressor

The air compressor shall be of the oil injected rotary screw type, designed and installed to supply a minimum of 60 cfm @ 125 psi (1699 L/min @ 8.6 b) of free air at maximum engine rpm. The compressor air/oil receiver shall be built and designed by the compressor manufacturer. A spin-on oil filter shall also be integrated into the compressor system. Replacement elements shall be readily available.

The air compressor shall be driven via a dry *Gates Poly-chain*® drive from the engine crankshaft and will be mounted to a bracket carried by the engine. The air compressor shall be capable of maintaining prolonged pressure to 150 psi (10.3 b) throughout the service life of the complete CAFS unit.

A pneumatic modulating inlet valve mounted on the air end inlet shall control the compressor. An Auto Odin balancing system shall be provided to automatically maintain the air pressure within plus-or-minus 5% of the water pump pressure throughout the CAFS operating range.

The cooling water to the heat exchanger shall be supplied through a dedicated, filtered line, from the units water pump. Water shall flow through the heat exchanger whenever the water pump is operating. The air compressor cooling system shall incorporate a thermostat that maintains the system oil temperature within a 168°F (75.6°C) to 225°F (107.2°C) range. The system shall be capable of maintaining recommended operating temperatures throughout the full operational range in ambient temperatures up to 115°F (46.1°C). A dry cartridge type air filter shall be provided on the compressor air intake.

Foam Proportioner

The automatic foam proportioner shall be the *Darley Fast Foam 50*. It shall be provided and installed to inject foam concentrate into all foam discharges. The proportioner shall automatically meter the correct percentage of foam concentrate, based on current flow, into the water stream. A check valve shall be provided ahead of the foam injection point to prevent foam solution back-flow. The concentrate pump shall be a 12 VDC, electrically driven, positive displacement pump. The concentrate pump shall be rated to flow ½ gpm @ 150 psi (1.89 L/min @ 10.3 b). The proportioner on/off switch, ratio controls, operating instructions and low concentrate warning light shall be mounted on the pump panel.

¹ Specifications are subject to change and improvements without notice.

® *Gates Poly-Chain* is a registered trademark of the Gates Corporation, dba The Gates Rubber Company.



Drive System

The water pump shall be directly driven using a centaflex coupling on an extension shaft in line with the crankshaft of the engine. The compressor, which will be mounted to the engine flywheel housing, shall be belt-driven using a *Gates Poly-chain®* belt.

Electrical System

All electrical equipment installed by the manufacturer shall conform to current automotive electrical system standards and the requirements of the applicable NFPA apparatus standards. The wiring shall be individually and permanently color and function coded. The installation shall meet SAE Standard J1128 in its latest edition for GXL or SXL temperature rating.

All exposed wiring shall run in loom with a minimum of 280°F (137.8°C) rating. All wiring loom shall be properly supported and attached to frame members along the entire run. At any point where wire or looms must pass through metal, rubber grommets shall be installed to protect the wire from abrasion.

The main low voltage electrical terminal block and circuit breaker panel shall be provided behind the pump operator's panel in a location providing easy service access.

The electrical connections shall be made using heat shrink and/or weatherproof connectors. All electrical circuits shall be protected with ATO blade type fuses.

Priming System

A *Darley* 12 VDC electric, oil-less, rotary-vane priming system shall be utilized. The primer is capable of priming the water pump through 20' of hard suction hose with a 10' lift. Primer controls and instruction plate shall be mounted on the operator's panel.

Plumbing, Hoses and Lines

All piping shall be stainless steel. All valves (unless otherwise specified) shall be two (2) piece brass quarter turn ball valves. Uses of grooved end pipe couplings are required for flexibility and movement of system components on mobile equipment. The compressor manufacturer shall supply all air compressor control lines. Hydraulic hoses will only be used for air injection lines and not control air lines. Flexible piping may be used where applicable. Check valves are required throughout the system to maintain integrity and shall be placed so that the air, water foam and foam solution do not inadvertently mix.

Tank to Pump

There shall be a 2" tank to pump suction valve fitted in the module and controlled from the operator's panel with a push/pull T-handle control.

Inlets

Suction piping shall be stainless steel. A 2½" NH Male adapter and cap shall be provided at the operator's panel for drafting.

Direct Tank Fill

The direct tank fill shall be 1½" stainless steel pipe with a 1½" ball valve on the control panel. The inlet shall be 2½" NH female swivel.

Water Only Discharge

There shall be a 1½" NH Male panel mounted Water Only discharge outlet with valve.

CAFS Discharge

There shall be a 1½" NH Male CAF outlet on the panel, controlled by the single mix point. A swing check valve shall be installed on the mix point to prevent foam from back flowing into the pump. The

® *Gates Poly-V* is a registered trademark of the Gates Corporation, dba The Gates Rubber Company.



CAF mix point controls shall be grouped together on the panel with easy to read calibration marks laser cut into the panel. The mix point foam solution valve shall be an *Akron* 1 ½” self-locking, swing-out valve.

Tank Refill

A 1 ½” tank refill line with a Locking, Push/Pull, T-Handle valve shall be provided.

Module Frame

The frame shall be constructed of aluminum and designed for rigorous use by fire service personnel. The top of the module shall be a laser-cut, aluminum diamond-plate material, stainless steel hinged for a complete service access door. The top access door shall use pneumatic gas shocks to maintain the door in the open position.

Corrosion Resistance Treatments

Dielectric tape (laminating type UHMW) is used through out the construction of the module for dissimilar metal contact surfaces. This will include, but not be limited to control panel to frame, engine mounts to frame, and solution injection unit to frame.

All SS screws, which secure the SS panel to the aluminum frame, will be treated with dielectric liquid. The majority of fasteners throughout the module will be SS. All electrical ground connections to the frame will be treated with dielectric silicone compound. Wire ends will have waterproof and corrosion resistant shrink tube, adhesive lined type terminals and connectors. All electrical plugs in the module will be environmentally sealed Deutsch type.

The entire surface of the electric fuse / connection box will be treated with a urethane seal coat to seal out moisture.

Control Panel

A brushed stainless steel, laser-cut control panel shall be mounted to the frame. The following items shall be positioned and clearly marked in a logical manner on the control panel to provide for simple and easy operation.

- 1) LED Pump Panel Light Cluster & Switch
- 2) 4” Black Face, Master Water Pressure Gauge
- 3) 4” Black Face, Master Air Pressure Gauge
- 4) Primer Control
- 5) Tank Refill Valve, Locking, Push/Pull, T-Handle
- 6) Tank to Pump valve, Locking, Push/Pull, T-Handle
- 7) Suction Inlet, 2½” NH Male with Cap & Lanyard
- 8) 1 ½” NH Male Water Only Discharge with Panel Mount Valve
- 9) Vernier Throttle Control
- 10) System Operation Instruction Placard
- 11) Panel Discharge CAFS Outlet 1½” NH Male with Cap & Lanyard
- 12) Darley Fast Foam 50 Proportioner Control
- 13) One (1) Set of Mix Point Controls
 - a) Water Solution Valve
 - b) Quarter-Turn Air Injection Control Valve
 - c) Quarter-Turn Mix Point Pressure Drain Valve
- 14) Lofa engine control module
 - a) Hour meter
 - b) Tachometer
 - c) Ignition switch
 - d) Battery charge light
 - e) Glow plug light
 - f) Low oil pressure light
 - g) Engine High Temperature light
 - h) Low water pressure light
 - i) High compressor temperature light



Labels

All controls, inlets and discharges shall be clearly labeled. The labels shall comply with applicable NFPA standards.

Testing

The completed unit shall undergo a manufacturer’s run-in test prior to delivery. The engine, pump and air compressor shall be operated for a minimum period of six (6) hours, during which time the test operator shall monitor and record the functions and performance of each system component. Compressed air foam shall be produced during the test.

This testing shall be performed to ensure proper system operation and performance prior to shipment. The manufacturer shall provide written certifications that the tested unit meets all performance criteria contained herein (NFPA). Water flow performance shall be tested in accordance with NFPA 1911. Airflow performance shall be measured with a temperature and pressure compensated air flow meter.

Manuals

One (1) copy of the *Operation and Maintenance Manual* and a CD copy shall be provided to the purchaser with each unit. This manual shall include detailed instructions in the operation and maintenance of the overall unit, engine, water pump, air compressor and foam proportioner.

Dimensions

Length	54.5”
Width	47.5”
Height	36.5”
Weight	1250 (408 Kg) lbs

Performance

Water Pump	135 gpm @ 150 psi	(511.03 L/min @ 10.36 b)
	160 gpm @ 100 psi	(605.7 L/min @ 6.9 b)
Air Compressor	60 cfm @ 125 psi	(1699 L/min @ 8.6 b)
Simultaneous Flow (NFPA)	100 gpm & 50 cfm @ 125 psi	(378.5 L/min & 1415.8 L/min @ 8.6 b)
Simultaneous Flow	130 gpm & 60 cfm @ 100 psi	(492.1 L/min & 1699 L/min @ 6.9 b)
Engine Horsepower	33.5 hp @ 3000 rpm	
Fuel Use @ Full Load	1.6 gph	(6.1 L/hr)

Warranty²

Engine	1 year
Compressor	1 year
Water Pump	3 year/3000 hours
Chemical Injector	1 year
Water Tank	Lifetime

² Covered by the original manufacturer’s warranty.



All fabrication and materials are warranted for a period of two (2) years barring accidents, abuse or negligence. Excluding from warranty are all consumables and parts subject to routine replacement. We will repair or assist in the repair or replacement of the product in its entirety.

Mustang Options

The list of options, which follow, can be added to the standard Mustang module according to your specifications and needs of operation. These options are not included in the base price of the Mustang module.

Water Tank

The water tank shall be rectangular in configuration and shall have a capacity based on the chassis GVW. The tank shall be constructed of ½” polypropylene sheet. All joints and seams are to be nitrogen welded.

The tank cover shall be constructed of ½” polypropylene and shall incorporate hold-downs to assist in keeping the cover rigid under fast filling conditions. The cover shall have a combination vent and manual fill tower. The tower shall have a hinged cover and a ¼“ thick polypropylene screen.

There shall be two (2) standard tank outlets; one for the tank to pump suction line and one for the tank fill line. An anti-swirl plate shall be installed at the tank-to-pump outlet. A manufacturer’s warranty shall be included for the tank.

A 25-gallon (94.6 liter) polypropylene foam reservoir shall be provided as an integral part of the booster tank and shall contain a low-level sensor in the bottom of the tank to signal when the foam reservoir needs to be filled. The tank shall be plumbed to supply the foam proportioner pump with a minimum ¾” hose (size varies per customer specifications).

The tank shall include all fittings, adapters, senders, switches and hoses necessary for tank to module connections.

Skid Frame and Water/Foam Tank

An aluminum weldment sub-frame shall be provided to support the entire slide-in module, with the base constructed of 2” x 4” x ¼” tubing. The sub frame shall be strong enough to support the weight of the booster tank and pumping equipment while in the apparatus and during loading and unloading and shall be utilized as a base mount for the engine, compressor and pump. Square tubing uprights with angled gussets shall extend up from the rear of the sub frame for attachment of the full width operator’s panel. Provisions shall be incorporated in the sub frame to facilitate using a forklift for loading and unloading of the unit.

The tank shall be bolted to the skid frame with stainless steel hardware through full width integral flange mounts at the front and rear. The water tank shall be completely removable without dismantling the skid unit.

Hose Reel

The hose reel shall be of aluminum construction with fairleads and electric rewind, installed with 100’ of 1” *Niedner* HotStop hose with one 1” pistol grip ball valve and tip. The hose reel shall be mounted on top of the water tank and shall have a straight swivel inlet.

Suction Strainer

2” Bolt lid strainer – Requires different plumbing and suction inlet location.

Master Drain

One (1) master drain valve shall be provided on the control panel to completely drain the system to prevent freeze damage.



Water Level Gauge

One (1) electronic water level gauge shall be provided on the control panel.

Foam Level Gauge

One (1) electronic foam level gauge shall be provided on the control panel.

Lid

The lid shall be computer cut, ventilated, diamond plate aluminum with stainless steel hinge and pneumatic gas shock lift struts.

Sides

The sides shall be computer cut, ventilated, diamond plate aluminum.

Suction Valve

The suction valve shall be a 2” ball valve mounted on the control panel suction inlet.

Panel Discharge Valve (C.A.F.)

The discharge valve shall be a 1½” ball valve mounted on the control panel CAF outlet.

Preconnect or Hose Reel Discharge valves and Push Pulls

One or two auxiliary push pulls with associated valves and plumbing to “split” the mix point.

Auxiliary Air Outlet

A type “C” Female quick connect air fitting shall be mounted to the control panel.

Remote Start with Throttle Rocker

The remote control panel shall be pre-wired with plug-in connectors for ease of installation. The standard wire harness length is twenty-five feet (25’). The remote start option shall include the throttle rocker actuator mounted to the throttle linkage on the engine. The assembly shall include the following components mounted on a placard with the necessary labels permanently painted on the placard.

- 1) Low Oil psi Light
- 2) System High Temp. Light
- 3) Glow Plug Light
- 4) Low Water Pressure Light
- 5) FoamPro Remote On / Off Control (Requires Foam Pro 2000 Series option)
- 6) FRC Tank Vision Mini Water Tank Level Gauge
- 7) Throttle Rocker Switch
- 8) Ignition Switch
- 9) 97 dB Audible Alarm

Fast Foam 250

The automatic foam proportioner shall be the *Darley Fast Foam 250*. It shall be provided and installed to inject foam concentrate into all foam discharges. The proportioner shall automatically meter the correct percentage of foam concentrate, based on current flow, into the water stream. A check valve shall be provided ahead of the foam injection point to prevent foam solution back-flow. The concentrate pump shall be a 12 VDC, electrically driven, positive displacement pump. The concentrate pump shall be rated to flow 2½ gpm @ 150 psi (9.46 L/min @ 10.3 b). The proportioner on/off switch, ratio controls, operating instructions and low concentrate warning light shall be mounted on the pump panel.

FoamPro 1601

The foam proportioner shall be a *FoamPro* model 1601 automatic, 12 VDC, direct-injection system. It shall be capable of maintaining a solution ratio of 0.1% to at least 1% of class “A” foam. The pump shall be a plunger type positive displacement pump. The pump output shall be 1.0 gpm @ 200 psi (3.8 L/min @ 13.8 b). The motor shall be rated at 1/3 hp with a maximum amp draw of 19 amps @ 200 psi



(13.8 b). The proportioner shall be capable of using different types of class “A” liquid foam concentrates. This complete system will be mounted within the module.

FoamPro 2001

The foam proportioner shall be a *FoamPro* model 2001 automatic, 12 VDC, direct-injection system. It will provide push-button control of foam proportioning rates from 0.1% to 9.9%, in 0.1% increments. The pump output shall be 2.6 gpm @ 150 psi (9.84 L/min @ 10.3 b). The motor shall be rated at ½ hp with a maximum amp draw of 40 amps. The proportioner shall be capable of using different types of liquid foam concentrates. This complete system will be mounted within the module.

FoamPro 2002

The foam proportioner shall be a *FoamPro* model 2002 automatic, 12 VDC, direct-injection system. It will provide push-button control of foam proportioning rates from 0.1% to 9.9%, in 0.1% increments. The pump output shall be 5.0 gpm @ 150 psi (18.9 L/min @ 10.3 b). The motor shall be rated at ¾ hp with a maximum amp draw of 56 amps. The proportioner shall be capable of using different types of liquid foam concentrates. This complete system will be mounted within the module.

Shut Down “Safety” Circuit

Varieties of shut down circuits are available to meet the end users needs and must be specified on an individual basis. Shut down circuits can be controlled by water pump pressure, engine oil pressure, compressor temperature, engine temperature or a combination of shut down parameters. Shut down circuits are available as a fully automatic system or as a manual override system. Consult Odin to specify shut down circuits.



CONTROL PANEL

- 1. WATER LEVEL GAUGE
- 2. FOAM LEVEL GAUGE
- 3. FAST FOAM 50
- 4. WATER PRESSURE GAUGE
- 5. AIR PRESSURE GAUGE
- 6. PRIMER CONTROL
- 7. COMPRESSOR TEMP. GAUGE AND LIGHT
- 8. AUDIBLE ALARM
- 9. PANEL LIGHT
- 10. ENGINE CONTROL BOX
 - A. CHARGING LIGHT
 - B. OIL PRESSURE LIGHT
 - C. ENGINE HIGH TEMP. LIGHT
 - D. GLOW PLUG LIGHT
 - E. FUEL FILTER LIGHT
 - F. HOUR METER
 - G. FUSE
 - H. IGNITION SWITCH
- 11. MIX POINT FOAM SOLUTION VALVE
 - A. FOAM SOLUTION VALVE
 - B. AIR INJECT VALVE
 - C. MIX POINT DRAIN VALVE
- 12. OPERATING INSTRUCTIONS
- 13. SUCTION INLET (VALVE OPTIONAL)
- 14. THROTTLE
- 15. TANK TO PUMP VALVE
- 16. TANK REFILL
- 17. DIRECT TANK FILL (OPTIONAL)
- 18. AUX AIR OUTLET (OPTIONAL)
- 19. WATER ONLY DISCHARGE
- 20. WINTERIZING MASTER DRAIN
- 21. PANEL CAFS DISCHARGE (VALVE OPTIONAL)

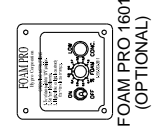
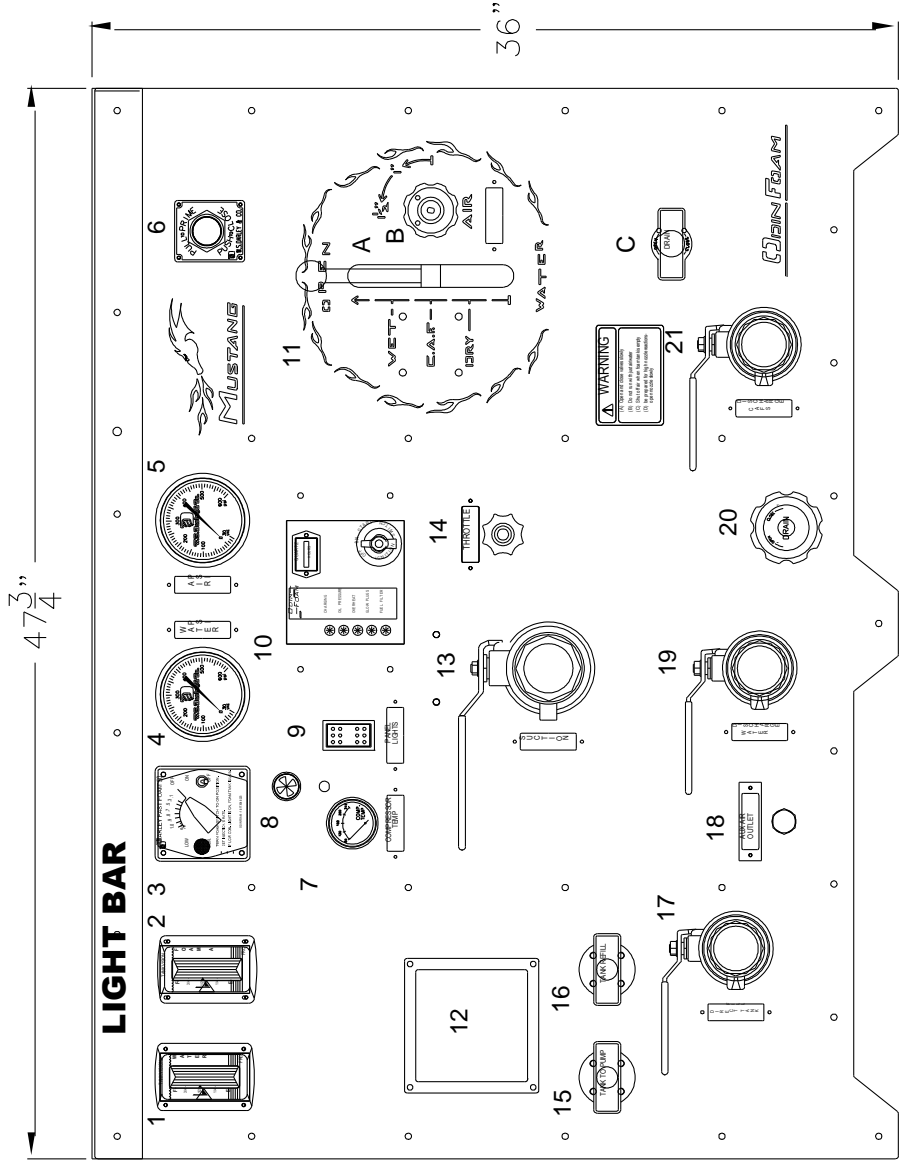

FOAM PRO 1601 (OPTIONAL)

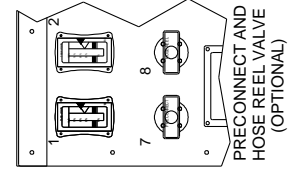
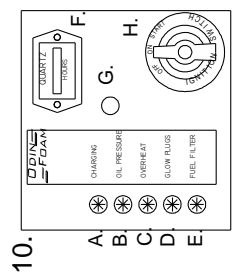
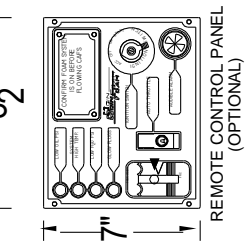

ODIN FOAM
TOLEDO, OREGON 97391 - 541.336.5067

MUSTANG
CONTROL PANEL LEGEND

DATE: 11.14.07
DRWN: HAGER
SCALE:

MUSTANG

THIS DESIGN IS THE PROPERTY OF ODIN FOAM - UNAUTHORIZED REPRODUCTION IS PROHIBITED



Mustang 100/50	Engine Driven C.A.F.S.
Standard Equipment	
<ul style="list-style-type: none"> • Engine- Kubota, Liquid Cooled, 4 Cylinder 33.5 hp, Indirect Injection, Naturally Aspirated Diesel Engine, 12 VDC Electric Start, Hour-Meter, Vernier Throttle • Control Panel – Illuminated, Laser Cut, Brushed Stainless Steel Panel with all Engine, Air Compressor, Water Pump and Foam Injection System Controls, Gauges and Instruments Installed • Air Compressor – Rotary Screw Compressor Assembly, Auto Odin Balance Valve, Compressor Temperature Gauge with Alarm 	<ul style="list-style-type: none"> • Pump System – Darley Model 1½ AGE with One (1) Independent 1½” CAF Discharge Mix Point, One (1) 2.5” Tank to Pump Suction Inlet, 12 VDC Electric Primer System and Stainless Steel Plumbing • Frame – Lightweight Aluminum with Fork Lift Provisions • Foam Proportioner System – Darley Fast Foam 50 • Direct Tank Fill
Mustang Options	
300/25 Gallon Poly Water/Foam Tank with Tank Kit, Installed on Full Skid Frame	
Tank (Shipped Loose) with Tank Kit – All Fittings, Boots, Clamps, Pipes, and Tank Mount Rubber Necessary to Connect the Mustang to a Water/Foam Tank	
1½” Discharge Valve with 1½” NH Chrome Adapter (<i>Necessary for Multiple Discharge Points</i>)	
Cap – Chrome 1½” NH with Lanyard (for Discharge Valve)	
Plug – Chrome 1½” NH with Lanyard	
Plug – Chrome 2½” NH with Lanyard	
Sides – Ventilated, Precision Computer Cut (<i>2 each</i>)	
Discharge Push pulls and valves (for pre connects etc.)	
Hose Reel – Installed with 100’ of 1” Niedner HotStop Hose, 1” Pistol Grip Ball Valve and Tip	
Level Gauge – Water or Foam (<i>price each</i>)	
Suction Strainer – 2” Bolt Lid Strainer	
Suction Valve – 2” Panel Mount	
Master Drain Valve – Winterizing Valve	
Fast Foam 250 Proportioner (Replaces Fast Foam 50 Proportioner)	
<i>FoamPro</i> 1601 Proportioner (Replaces Fast Foam 50 Proportioner)	
<i>FoamPro</i> 2001 Proportioner (Replaces Fast Foam 50 Proportioner)	
<i>FoamPro</i> 2002 Proportioner (Replaces Fast Foam 50 Proportioner)	
Auxiliary Air Outlet-Type “C” Female quick connect fitting mounted on the control panel	
Remote Start with Throttle Rocker – Includes Ignition Switch, Low Oil Pressure Light, Engine High Temperature Light, Charge Light, Compressor High Temperature Light, Audio Alarm, Throttle Rocker Switch, Electric Throttle Installed on Linkage, 25’ of Coded Wire with Packard Connectors, Tested (<i>Shipped Loose</i>)	
Remote Start with Throttle Rocker (for FP 2001+) – Includes Ignition Switch, Low Oil Pressure Light, Engine High Temperature Light, Charge Light, Compressor High Temperature Light, Audio Alarm, Throttle Rocker Switch, Remote Start/Stop for FP, Electric Throttle Installed on Linkage, 25’ of Coded Wire with Packard Connectors, Tested (<i>Shipped Loose</i>)	

