

# W.S. Darley & Co.

TRUSTED WORLDWIDE SINCE 1908



## Pump Plant & Engineering

1051 Palmer Street  
Chippewa Falls, WI 54729  
Phone 800-634-7812  
Fax 715-726-2656

## Pump Sales & Corporate

325 Spring Lake Dr.  
Itasca, IL 60143-2072  
Phone (708) 345-8050  
Fax (708) 345-8993

Date: \_\_\_\_\_

Bill To: \_\_\_\_\_

P.O. No.: \_\_\_\_\_

\_\_\_\_\_

Customer No.: \_\_\_\_\_

\_\_\_\_\_

Order Completed By: \_\_\_\_\_

\_\_\_\_\_

Desired Delivery Date: \_\_\_\_\_

Ship To: \_\_\_\_\_

End Customer: \_\_\_\_\_

\_\_\_\_\_

Customer Contact:

\_\_\_\_\_

Tel No.: \_\_\_\_\_

\_\_\_\_\_

Fax No.: \_\_\_\_\_

Email: \_\_\_\_\_

# PUMP ORDER FORM

## LSM / LSMH PUMP

Please review the order form before starting. If any challenges arise, please call our Customer Service Department at (800) 634-7812 for assistance. We will be glad to help. Please fill in the information **completely**.

**Rated capacity: (choose either GPM or LPM)**

GPM:  500     750     1000

LPM:  2000     3000     4000

\*If special testing is required, please indicate your need.

Imperial Gallons (List Capacity) \_\_\_\_\_

Liters per Minute (List Capacity) \_\_\_\_\_

Other (Specify) \_\_\_\_\_

### CHASSIS INFORMATION

Chassis make: \_\_\_\_\_ Transmission Make: \_\_\_\_\_

Model: \_\_\_\_\_ Model: \_\_\_\_\_

Engine: \_\_\_\_\_ Color: \_\_\_\_\_

HP: \_\_\_\_\_ Altitude: \_\_\_\_\_ FT.

@ \_\_\_\_\_ RPM Wheelbase: \_\_\_\_\_

Electrical system:  12V     24V Cab to Axle: \_\_\_\_\_

Air Breaks:  Yes     No Body Width:  70"     72"

Pump Gear Ratio: \_\_\_\_\_

Control Location:  Side Panel     Top Console

Lowest Gear/Torque Converter Ratio: \_\_\_\_\_

### PUMP DRIVE SHAFT INFORMATION

1. Measure distance across lugs of universal joint yoke to determine Spicer yoke series.
2. Check box of appropriate size below.
3. Spicer Lockon yoke supplied on front and rear of pump.

**NOTE:** If chassis driveline is not one of Spicer yokes listed, contact Darley Engineering.

Distance across lugs	Spicer Yoke Series
<input type="checkbox"/> 4.97	1550
<input type="checkbox"/> 5.31	1610(Companion Flange Only)
<input type="checkbox"/> 6.09	1710 (standard)
<input type="checkbox"/> 7.00	1760
<input type="checkbox"/> 7.55	1810

## PUMP RATING

- NFPA 1901 Fire Pump  
 Other: \_\_\_\_\_

### (Options, Fill in choices)

**Primary water type:**  Salt water  Fresh water

**Pump material:**  Cast Iron  Bronze (Recommended for salt water)

**Pump position:**  Rear  Front  
(3 Gear only)

**Seal type:**  Packing  Mechanical Seal

**Electric Primer:**  12V  24V  None

**Primer type:**  Fluid  Fluid-less

**Mounting Kit:**  Standard

#### Inline Butterfly Valve:

Hand wheel Operated **OR**  Electric Actuated

Manual Vented **OR**  Automatically Vented

#### Inline Butterfly Valve Size:

4"  5"  6"

#### Inline Butterfly Valve Piping Size:

NPT  Weld

#### Discharge Valves: (shipped loose)

2-1/2" NH Straight Nipple  2-1/2" NH 30° Down Nipple

#### Suction Valves: (shipped loose)

2-1/2" NH Female  2-1/2" NH Female "Full Flow"

- 2-1/2" Inline Valve**
- 3/4" Valve Drains** (available on suction or discharge valves)
- Pressure Relief Valve with Remote Control and Pilot Light** (Shipped loose)
- Suction Relief Valve with Remote Control** (Shipped loose)
- Tachometer Cable (cable only)**
- Hand Speed Counter and Cable**
- Electric Tachometer, Speed Counter and Cable**
- Master Drain Valve (8 openings)**
- Isolated Ports Multiple Drain (6 openings)**
- Pump Overheat Protection System**
- Air Power Shift**
- Remote Packing Adjustment Cables**

**Options only for the LSMH Pump** (high pressure second stage pump)

- High Pressure Second Stage Pump**
- Air Power Shift Second Stage / with Safety Interlock**

# W.S. Darley & Co.

## LSM/LSMH PUMP ORDER FORM

CHECK BOX FOR APPROPRIATE CHOICE OF EACH:

1. SUCTION FLANGE SIZE.
2. DISCHARGE FLANGE SIZE.
3. PUMP FORWARD OR PUMP REAR.
4. 3-GEAR TRANSMISSION OPTION.
5. HIGH PRESSURE PUMP OPTION.

FLANGE SIZE

- 4" NPT  
 4" WELD  
 5" NPT  
 5" WELD  
 OPTIONAL: DISCHARGE HEAD (SEPARATE PAGE)

OPTIONAL: DISCHARGE HEAD (SEPARATE PAGE)

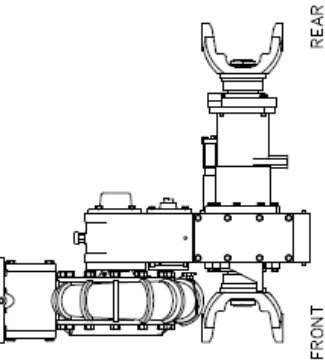

- PUMP FORWARD OF GEARCASE  
 PUMP REAR OF GEARCASE

- 3-GEAR TRANSMISSION  
 PUMP REAR SHOWN WITH OPTIONAL HIGH PRESSURE PUMP

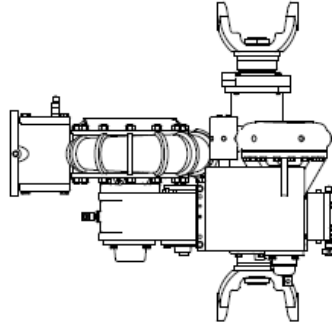

- OPTIONAL: HIGH PRESSURE PUMP

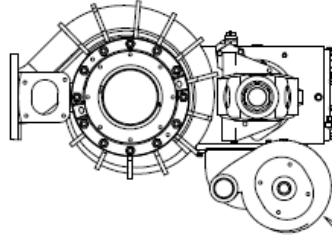

FLANGE SIZE

- 6" NPT  
 6" WELD  
 6" SUCTION TEE VICTAULIC  
 6" 45° SUCTION EXTENSION (USE WITH 6" SUCTION TEE FOR ADDITIONAL DRIVELINE DROP)

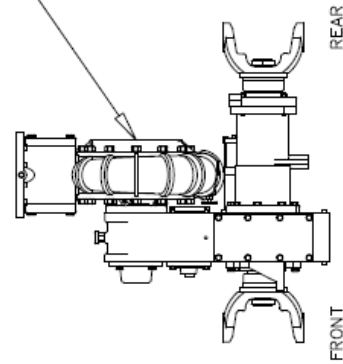

FRONT REAR

12/2016  
 REV. 4  
 JUL 2001  
 LN  
 Rev Date: 09/2008  
 R/JG

# Crating options/Instructions

- Standard Box
- Wood Crate, Bark Free
- Heat Treated Skid (Export)
- Oversized Domestic Skid and Box (38x44)
- Oversized Export Skid and Box (38x44)
- Oversized Heat Treated Skid (Export 38x44)
- Special Crating Instructions: \_\_\_\_\_  
\_\_\_\_\_  
\_\_\_\_\_  
\_\_\_\_\_  
\_\_\_\_\_

